

Repair Parts Manual

C C O U N T R Y
CLIPPER®
Z E R O T U R N M O W E R

B O S S ^{**XL**}

1525

SERIAL RANGE: 17255001 - 19243999

COUNTRY CLIPPER

BOSS XL

1525

SERIAL RANGE: 17255001 - 19243999

ZERO TURN RADIUS MOWER

TABLE OF CONTENTS

SECTION 1 – MOWER DECKS AND RELATED PARTS

1. 60" DECK ASSEMBLY
2. 72" DECK ASSEMBLY
3. DECK SPINDLE ASSEMBLY
4. CHUTE ASSEMBLY
5. LIFT HANDLE ASSEMBLY & RELATED PARTS
6. QUICK RELEASE SYSTEM (QRS) PARTS - 60" & 72" DECKS

SECTION 2 – TRACTOR FRAME AND RELATED PARTS

7. LIFT ASSEMBLY & RELATED PARTS - 60" DECK
8. LIFT ASSEMBLY & RELATED PARTS - 72" DECK
9. STEP & RELATED PARTS
10. DOUBLE IDLER & RELATED PARTS
11. ANTI-ROTATING CASTER WHEEL & RELATED PARTS
12. FRAME SIDES & RELATED PARTS
13. FRAME SIDES & RELATED PARTS (CON'T)
14. FRAME SIDES & RELATED PARTS (CON'T)
15. FENDER ASSEMBLY
16. SEAT FRAMING & RELATED PARTS
17. SEAT FRAMING & RELATED PARTS (CON'T)
18. R.O.P.S. ASSEMBLY (ROLL OVER PROTECTION SYSTEM) & RELATED PARTS

SECTION 3 – TRACTOR DRIVE AND RELATED PARTS

19. FUEL TANK ASSEMBLY
20. JOYSTICK & RELATED PARTS (RIGHT SIDE)
21. JOYSTICK & RELATED PARTS (LEFT SIDE)
22. JOYSTICK ASSEMBLY
23. TWIN STICK STEERING CONTROL & RELATED PART
24. PARKING BRAKE & RELATED PARTS
25. TRANSMISSION & RELATED PARTS
26. HYDRO IDLER & RELATED PARTS
27. ENGINE & RELATED PARTS
28. WIRE HARNESS & RELATED PARTS (JOYSTICK)
29. WIRE HARNESS & RELATED PARTS (TWINSTICK)
30. JACK ASSEMBLY

60" DECK ASS'Y {643AF-002A}

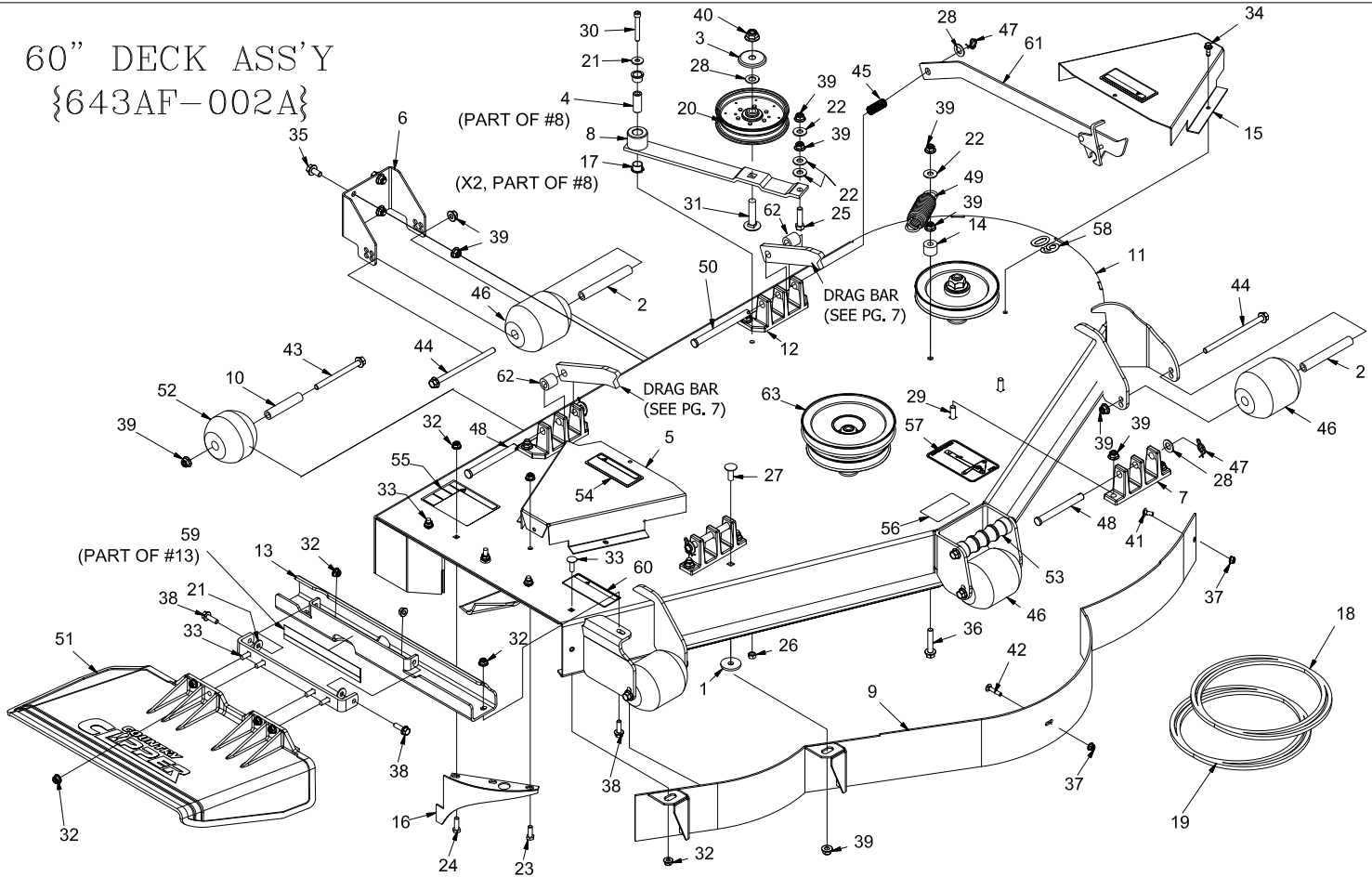

REF NO.	PART NO.	QTY.	DESCRIPTION	REF NO.	PART NO.	QTY.	DESCRIPTION
1	609-034P	13	Spindle Spacer Washer	33	F-2066	8	5/16-18 x 1" CARRIAGE BOLT,
2	609-183P	4	BUSHING	34	F-2119	2	FHCS, 1/4-20 x 0.75, YZ, LOCK PATCH, GR5
3	620-201P	1	WASHER, BEARING CAP	35	F-2124	4	FHCS, 3/8-16 x 0.75, YZ, GR5
4	621-103P	1	MOUNTING PIN	36	F-2126	1	FHCS, 3/8-16 x 2.00, YZ, GR5
5	668-077A	1	PULLEY COVER w/DECALS	37	F-2132	2	NUT, 1/4-20 NYLOC, FLANGED
6	637-006P	1	SCALPER BRKT.	38	F-2148	3	FHCS, 5/16-18 x 1.00, YZ, GR5
7	643-016W	2	Hanger Weldment	39	F-2151	24	Nut, 3/8-16 Nyloc, Flanged
8	643-079A	1	SINGLE IDLER ARM LONG ASS'Y	40	F-2152	1	Nut, 1/2-13 Nyloc, Flanged
9	643-104W	1	60" DUST BAFFLE WELDMENT	41	F-2155	1	Carriage Bolt, 1/4 X 5/8"
10	643-126P	2	BUSHING	42	F-2157	1	CARRIAGE BOLT, 1/4 X 1-1/4"
11	643-143A	1	60" DECK w/DECALS	43	F-2160	2	FHCS, 3/8-16 x 4 1/2", YZ, GR5
12	651-009W	2	CASTING, HANGER, WIDE BASE	44	F-2161	5	FHCS, 3/8-16 x 6", YZ, GR5
13	643-135A	1	OUTLET STIFFENER, w/DECAL	45	F-2575	1	SPRING, COMP .656 X .052 X 1.97
14	668-045P	1	SPACER, SPRING MTG	46	H-1948	4	Roller, 3-3/4 DIA. x 4-13/16L
15	668-061A	1	PULLEY COVER w/DECALS	47	H-2239	4	1/2" Rue Ring
16	686-006W	1	SPLITTER BAFFLE	48	H-2240	3	1/2" x 4-1/2" Clevis Pin
17	D-3730	2	FLANGED BUSHING	49	H-2619	1	SPRING, 5 X 1-1/2, TAPERED ENDS
18	D-3796	1	V-BELT B-124 (DECK)	50	H-2718	1	1/2" x 5-1/2" Clevis Pin
19	D-3901	1	V-BELT, B-112", (CLUTCH TO DECK)	51	H-2723	1	Chute, Discharge, Small
20	D-3904	1	PULLEY, FLAT IDLER, 5" (NTN)	--	643-111A	1	CHUTE ASSEMBLY
21	F-1009-02	3	5/16" Flat Washer	52	H-2772	2	Roller, 3-3/4 DIA. x 3 1/4"L
22	F-1009-03	4	3/8" Flat Washer	53	H-2787	1	GRIP, DECK HANDLE
23	F-1015-14	1	5/16-18 x 7/8" Capscrew	54	P-10935	2	Decal, WARNING
24	F-1015-15	1	5/16-18 x 1" Capscrew	55	P-10941	1	DECAL "DANGER ROTATING BLADES"
25	F-1015-27	1	3/8-16 x 1-1/2" Capscrew	56	P-11413	1	DECAL, HOIST POINT
26	F-1125	1	5/16-18 Stover Nut	57	P-11935	1	Decal, Belt Routing
27	F-1274	1	3/8-16 X 1" CARRIAGE BOLT	58	P-11952	1	DECAL, DECK SIZE, 60
28	F-1521	5	1/2" WASHER, CUSTOM	59	P-12496	1	DECAL, MISSING CHUTE
29	F-1672	8	3/8-16 x 1-1/4" Carriage Bolt	60	P-12706	1	WARNING DECAL, DISCHARGE CHUTE
30	F-1800	1	5/16-18 SHSC 2-1/4"	61	625-114A	1	DECK PROP ASSEMBLY
31	F-1822	1	1/2-13 X 2-1/4" CARRIAGE BOLT	62	707-046P	2	SPACER
32	F-2063	13	Nut, 5/16-18 Nyloc, Flanged	63	-----	3	SPINDLE ASS'Y (SEE pg.3)

72" DECK ASS'Y {643AG-002A}

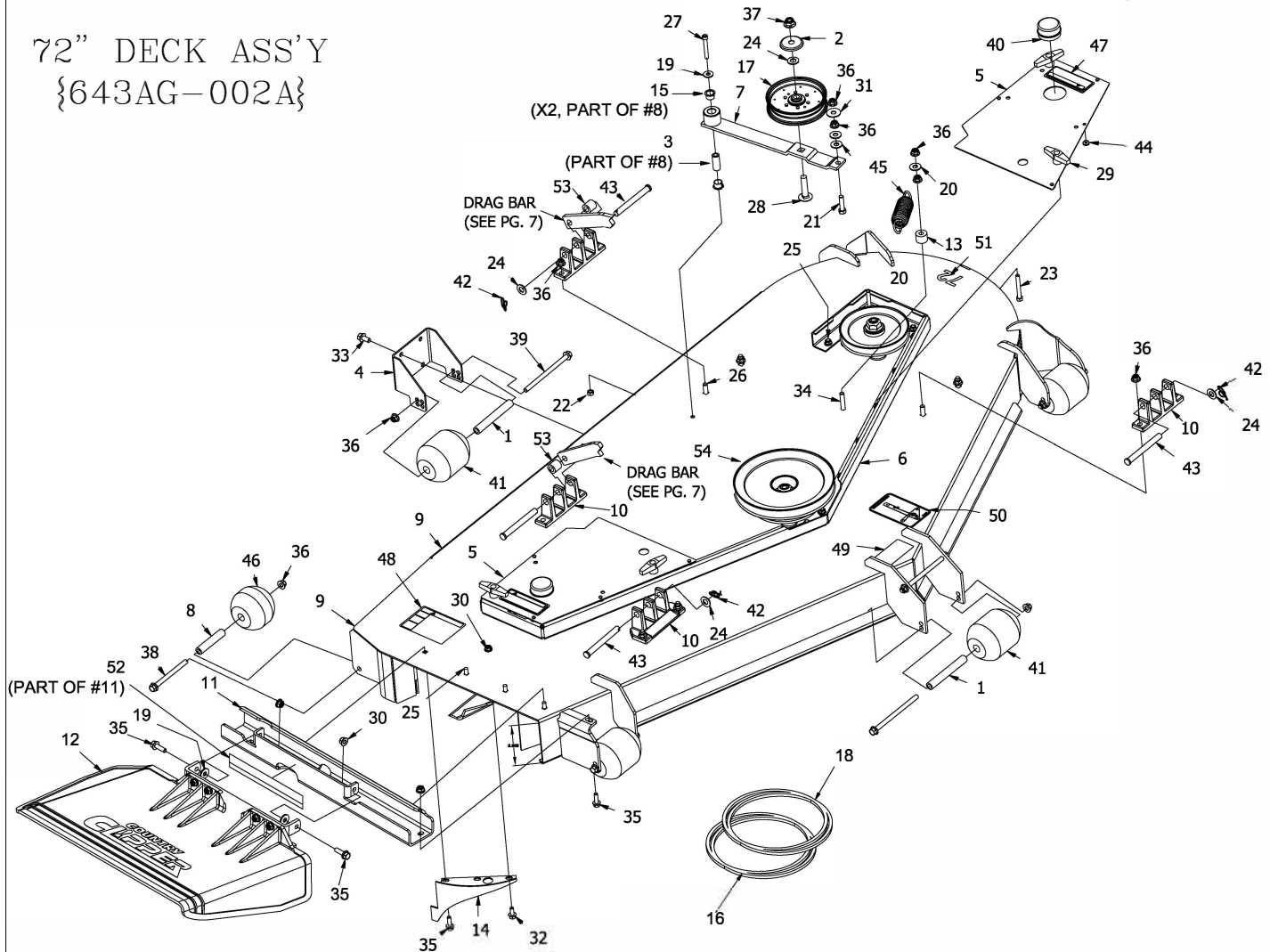

REF NO.	PART NO.	QTY.	DESCRIPTION	REF NO.	PART NO.	QTY.	DESCRIPTION
1	609-183P	4	BUSHING	28	F-1822	1	1/2-13 X 2-1/4" CARRIAGE BOLT
2	620-201P	1	WASHER, BEARING CAP	29	643-072A	4	T HANDLE ASS'Y W/ NUT
3	621-103P	1	MOUNTING PIN	30	F-2063	29	Nut, 5/16-18 Nyloc, Flanged
4	637-006P	1	SCALPER BRKT.	31	F-2083	1	WASHER, 3/8 FENDER
5	643-095A	1	PULLEY COVER w/DECALS (RH)	32	F-2120	1	FHCS, 5/16-18 x 0.75, YZ, GR5
--	643-132A	1	PULLEY COVER w/DECALS (LH)	33	F-2124	4	FHCS, 3/8-16 x 0.75, YZ, GR5
6	643-068P	1	TOP STIFFNER 72" DECK	34	F-2126	1	FHCS, 3/8-16 x 2.00, YZ, GR5
7	643-079A	1	SINGLE IDLER ARM LONG ASS'Y	35	F-2148	4	FHCS, 5/16-18 x 1.00, YZ, GR5
8	643-126P	2	BUSHING	36	F-2151	25	Nut, 3/8-16 Nyloc, Flanged
9	643-145A	1	72" DECK w/DECALS	37	F-2152	1	Nut, 1/2-13 Nyloc, Flanged
10	643-016W	4	HANGER	38	F-2160	2	FHCS, 3/8-16 x 4 1/2", YZ, GR5
11	643-135A	1	OUTLET STIFFENER w/DECAL	39	F-2161	5	FHCS, 3/8-16 x 6", YZ, GR5
12	643-111A	1	CHUTE ASSEMBLY	40	H-1798	2	2 GREASE CAP
13	668-045P	1	SPACER, SPRING MTG	41	H-1948	4	Roller, 3-3/4 DIA. x 4-13/16L
14	686-006W	1	SPLITTER BAFFLE	42	H-2239	4	1/2" Rue Ring
15	D-3730	2	FLANGED BUSHING	43	H-2240	4	1/2" x 4-1/2" Clevis Pin
16	D-3797	1	"V"-BELT B-142 (DECK)	44	H-2461	8	Rubber bumper
17	D-3904	1	PULLEY, FLAT IDLER, 5" (NTN)	45	H-2619	1	SPRING, 5 X 1-1/2, TAPERED ENDS
18	D-3902	1	"V"-BELT B-116 (CLUTCH TO DECK)	46	H-2772	2	Roller, 3-3/4 DIA. x 3 1/4"L
19	F-1009-02	3	5/16" Flat Washer	47	P-10935	2	Decal, WARNING
20	F-1009-03	3	3/8" Flat Washer	48	P-10941	1	DECAL "DANGER ROTATING BLADES"
21	F-1015-27	1	3/8-16 x 1-1/2" Capscrew	49	P-11413	1	DECAL, HOIST POINT
22	F-1125	1	5/16-18 Stover Nut	50	P-11935	1	Decal, Belt Routing
23	F-1518	4	5/16-18 x 2-1/2" Capscrew	51	P-11953	1	DECAL, DECK SIZE, 72
24	F-1521	5	1/2" WASHER, CUSTOM	52	P-12496	1	DECAL, MISSING CHUTE
25	F-1671	21	5/16-18 x 3/4" CARRIAGE BOLT	53	707-046P	2	SPACER
26	F-1672	10	3/8-16 x 1-1/4" Carraige Bolt	54	---	3	SPINDLE ASSY (SEE pg.3)
27	F-1800	1	5/16-18 SHSC 2-1/4"				

DECK SPINDLE ASSEMBLY 629FN-001A

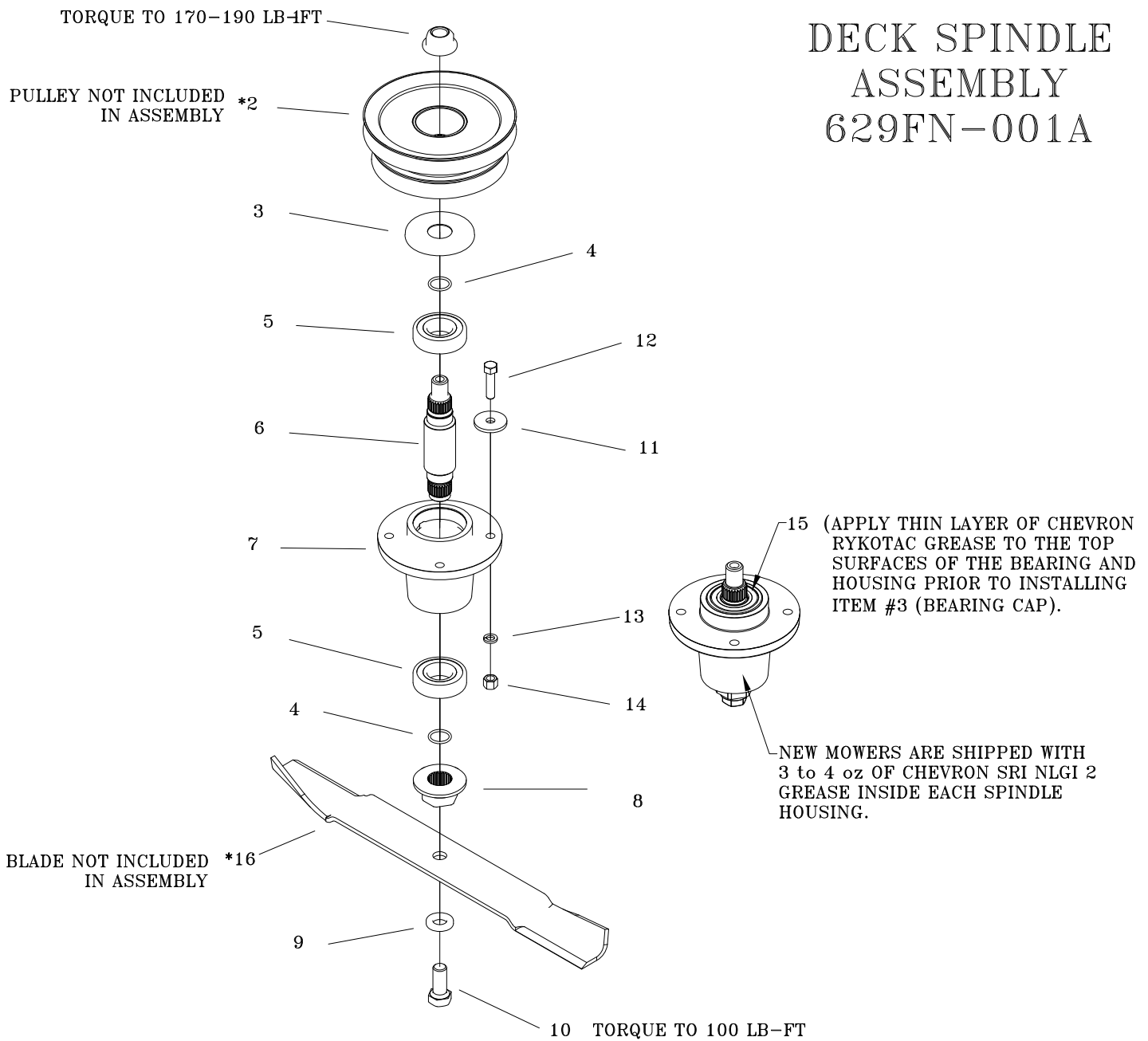

ITEM	PART #	QTY.	DESCRIPTION	ITEM	PART #	QTY.	DESCRIPTION				
1	F-2078	1	3/4-6 TOP LOCK NUT	15	H-2707	1	GREASE PACKET				
2	668-043P	*	60" DECK CENTER PULLEY (SHOWN)	16	H-2886	*	FUSION, HIGH LIFT, 60" DECK				
*	668-044P	*	72" DECK CENTER PULLEY	-	H-2887	*	FUSION, HIGH LIFT, 72" DECK				
*	668-042P	*	60" & 72" DECK OUTSIDE PULLEY	OPTIONAL BLADES							
3	609-292P	1	CAP, BEARING					*	H-2655	*	BLADE, HIGH LIFT 60" DECK
4	H-2639	2	O'RING, RUBBER					*	H-2656	*	BLADE, HIGH LIFT 72" DECK
5	D-3867	2	BEARING, #6206					*	H-2661	*	BLADE, LOW LIFT 60" DECK
6	609-289P	1	SHAFT, SPINDLE					*	H-2662	*	BLADE, LOW LIFT 72" DECK
7	609-285P	1	HOUSING, SPINDLE					*	H-2667	*	BLADE, GATOR 60" DECK
8	609-288P	1	BLADE DRIVER					*	H-2877	*	BLADE, GATOR 72" DECK
9	660-099P	1	BLADE WASHER								
10	F-2073	1	5/8-11 X 1.5 HHCS GR. 8								
11	609-034P	4	SPINDLE SPACER, WASHER								
12	F-1572	4	3/8-24 X 1.5 CAP SCREW								
13	F-1019-03	4	3/8 LOCK WASHER								
14	F-1573	4	3/8-24 LOCK NUT								

MOLDED CHUTE ASSEMBLY
 {643-111A}

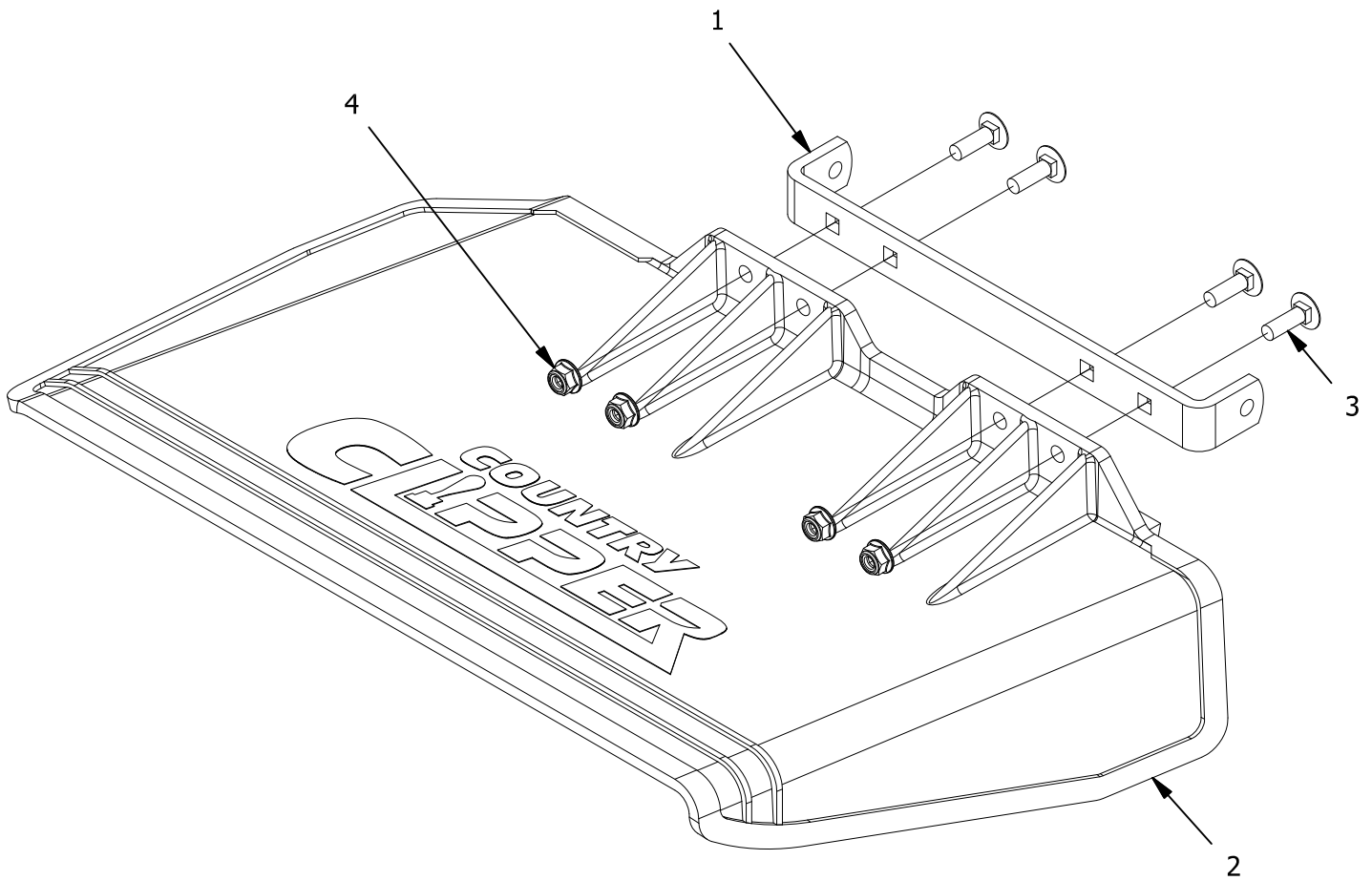

REF NO.	PART NO.	QTY.	DESCRIPTION
1	643-110P	1	CHUTE HINGE
2	H-2723	1	CHUTE, DISCHARGE, SMALL
3	F-2066	4	5/16-18 x 1" CARRIAGE BOLT,
4	F-2063	4	NUT, 5/16-18 NYLOC, FLANGED

LIFT HANDLE ASSEMBLY & RELATED PARTS

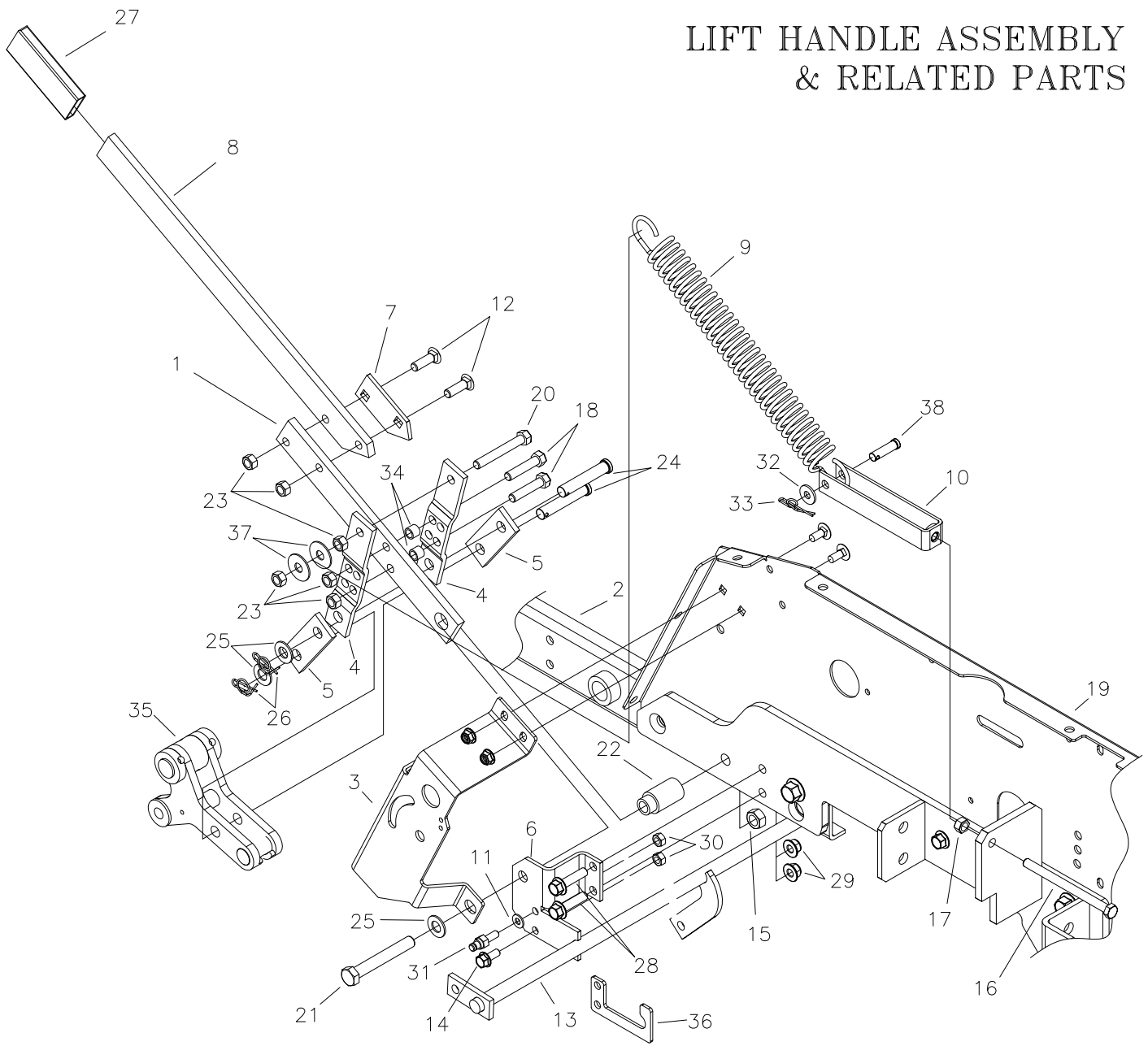

ITEM	PART #	QTY.	DESCRIPTION	ITEM	PART #	QTY.	DESCRIPTION
1	709-139P	1	BAR, LIFT HANDLE, LOWER	20	F-1542	1	CAPSCREW, 3/8-16x2 3/4" GR5
2	709-054W	1	FRAME SIDE WELDMENT, LH.	21	F-1828	1	1/2-13 X 3-1/2" GR. 5
3	709-184P	1	BRACKET, INNER BRAKE MNT	22	642-095P	1	HANDLE PIVOT PIN
4	642-060P	2	SPRING ANCHOR PLATE	23	F-1005-03	6	NUT, 3/8-16 LOCKNUT (STOVER)
5	642-061P	2	HANDLE LINK	24	F-1889	2	CLEVIS PIN, 1/2 X 2-5/8"
6	709-075P	1	BRACKET, HANDLE PIVOT	25	F-1521	3	1/2" FLAT WASHER
7	709-140P	1	PLATE, TOP PEG CATCH	26	H-2239	2	RUE RING, 1/2"
8	709-101P	1	BAR, LIFT HANDLE, UPPER	27	H-2324	1	VINYL GRIP, 3/8 X 1-1/2"
9	H-1610	1	SPRING, 1-1/2" OD. X 8"	28	F-2147	2	FHCS, 3/8-16x1-1/2", YZ, GR5
--	H-1868	1	SPRING, HEAVY 8" (72" DECK)	29	F-2151	2	NUT, 3/8-16, NYLOC, FLANGED
10	709-062W	1	YOKE, SPRING WLDT	30	F-1125	2	5/16-18, STOVER NUT
11	F-1009-01	1	FLAT WASHER, 1/4"	31	638-028P	1	DAMPER BOLT, 5/16-18x3/4"
12	F-1672	2	3/8-16 X 1-1/4" CARRIAGE BOLT	32	F-1009-02	1	FLAT WASHER, 5/16"
13	709-116W	1	BRAKE ROD WLDT	33	F-1492	1	5/16-3/8 RUE RING
14	F-2120	1	FHCS, 5/16-18x3/4", YZ, GR5	34	629-532P	2	SPACER
15	F-1005-05	2	NUT, 1/2-13 LOCKNUT	35	642-193P	1	REAR LIFT SLEEVE
16	F-1646	1	3/8-16 X 5" FULL THREAD	36	709-117P	1	BRACKET, BRAKE LINK
17	F-1011-03	1	HEX NUT, 3/8-16 UNC-2B	37	F-2083	2	WASHER, 3/8" FENDER
18	F-1015-28	2	CAPSCREW, 3/8-16x1-3/4" GR5	38	F-1444	1	CLEVIS PIN, 3/8 DIA X 1-5/16"
19	709-016P	1	SIDE PANEL, LH				

QRS SYSTEM PARTS

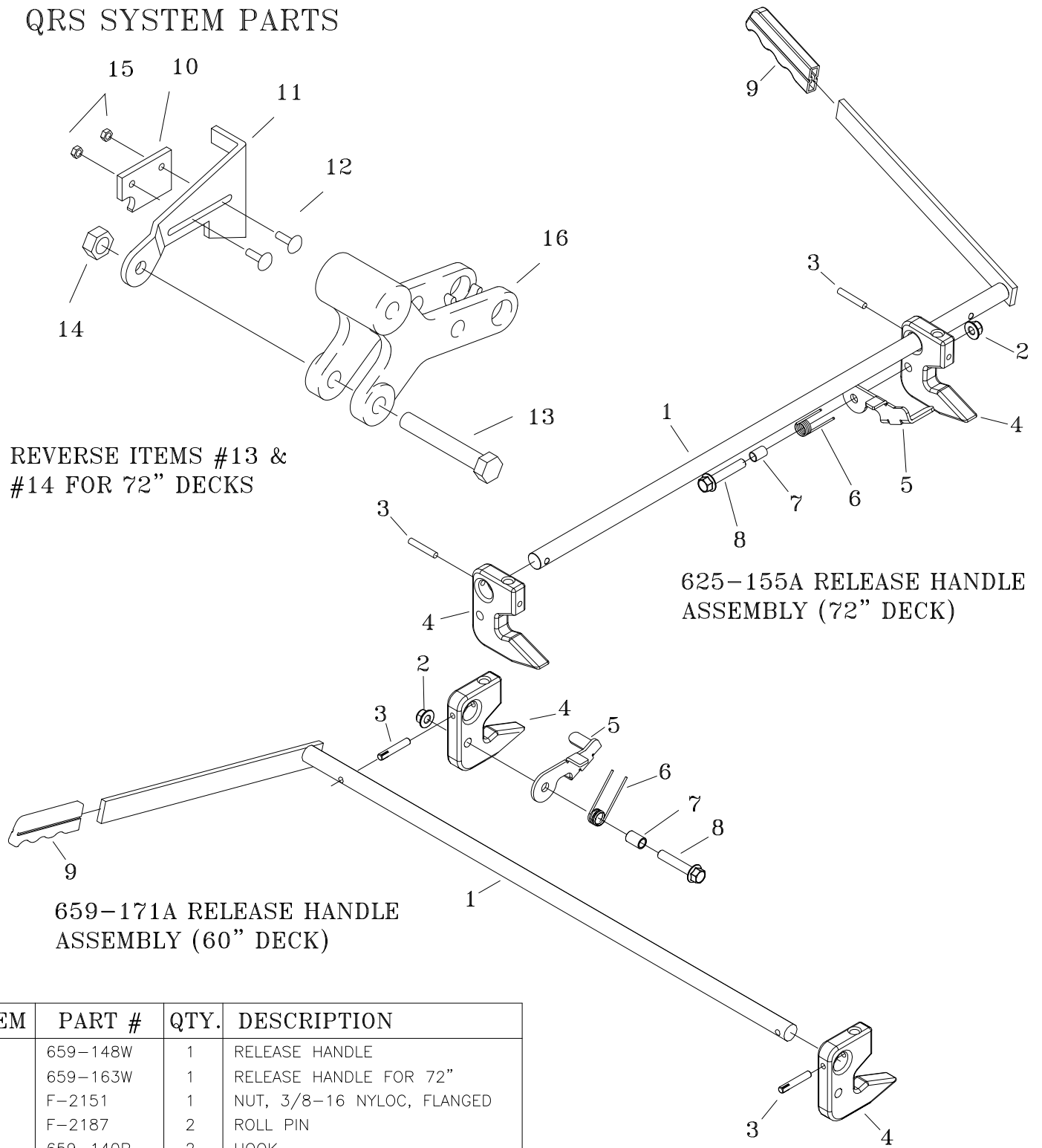

REVERSE ITEMS #13 &
#14 FOR 72" DECKS

625-155A RELEASE HANDLE
ASSEMBLY (72" DECK)

659-171A RELEASE HANDLE
ASSEMBLY (60" DECK)

ITEM	PART #	QTY.	DESCRIPTION
1	659-148W	1	RELEASE HANDLE
-	659-163W	1	RELEASE HANDLE FOR 72"
2	F-2151	1	NUT, 3/8-16 NYLOC, FLANGED
3	F-2187	2	ROLL PIN
4	659-140P	2	HOOK
5	659-372P	1	HOOK KEEPER
6	H-3011	1	SPRING
7	707-073P	1	SPACER
8	F-2218	1	FHCS, 3/8-16x2-1/4", YZ, GR5
9	H-1926	1	1/4x1 HANDLE GRIP
10	659-170P	1	CATCH
11	663-089P	1	LATCH PLATE
12	F-1823	2	1/4 X 3/4" CARRIAGE BOLT
13	F-1828	1	CAPSCREW, 1/2-13x3-1/2", YZ GR5 (60")
-	F-2163	1	FHCS, 1/2-13x3-1/2", YZ GR5 (72")
14	F-2152	1	NUT, 1/2-13 NYLOC, FLANGED
15	F-1158	1	1/4-20 STOVER NUT
16	642-193P	1	REAR LIFT SLEEVE

LIFT ASSEMBLY & RELATED PARTS 60" DECK

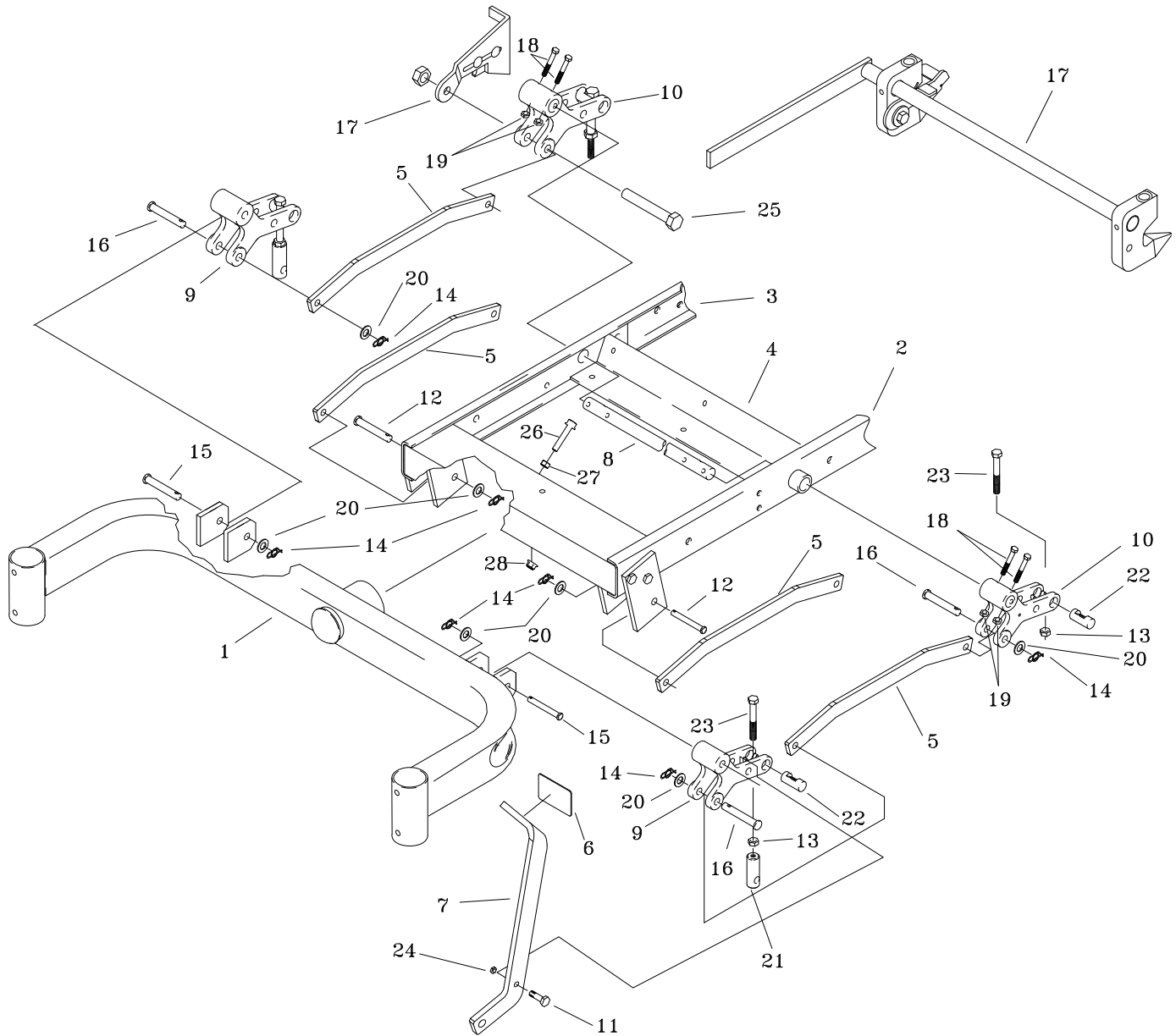

ITEM	PART #	QTY.	DESCRIPTION	ITEM	PART #	QTY.	DESCRIPTION
1	642-189W	1	FRONT AXLE WELDMENT	17	----	1	QRS SYSTEM, SEE PAGE #6
2	709-054W	1	FRAME SIDE WLDT, LH	18	F-2039	4	5/16-24 x 2" HHCS
3	709-055W	1	FRAME SIDE WLDT, RH	19	F-2041	4	5/16-24 LOCK NUT
4	709-157W	1	FRONT PIVOT CHANNEL	20	F-1521	8	WASHER, 1/2 NARROW
5	659-299P	4	LINK BAR	21	642-175P	2	ADJUSTABLE HANGER END
6	H-2401	1	1-1/2"x2-1/2" SAFETY TREAD	22	642-177P	4	HANGER PIN
7	659-056P	1	DECK LIFT PEDAL	23	F-1936	4	1/2-13 X 3-1/2, 2" THREAD
8	620-051P	1	LIFT BAR	24	F-1125	1	5/16 LOCKNUT
9	642-081P	2	LIFT SLEEVE, FRONT	25	F-1828	1	HHCS, 1/2-13x3-1/2", YZ, GR5
10	642-193P	2	LIFT SLEEVE, REAR	26	F-2126	1	FHCS, 3/8-16 x 2", YZ, GR5
11	F-1879	1	5/16-18 X 1 1/4", GR.5	27	F-1011-03	1	NUT, 3/8-16
12	F-1896	2	CLEVIS PIN, 1/2 X 1-3/4"	28	F-2151	1	NUT, 3/8-16 NYLOC, FLANGED
13	F-1489	4	NUT. 1/2" JAM				
14	H-2239	8	RUE RING, 1/2"				
15	F-1890	2	CLEVIS PIN, 1/2 X 3-1/2"				
16	F-1898	3	CLEVIS PIN, 1/2 X 2-3/4"				

LIFT ASSEMBLY & RELATED PARTS 72" DECK

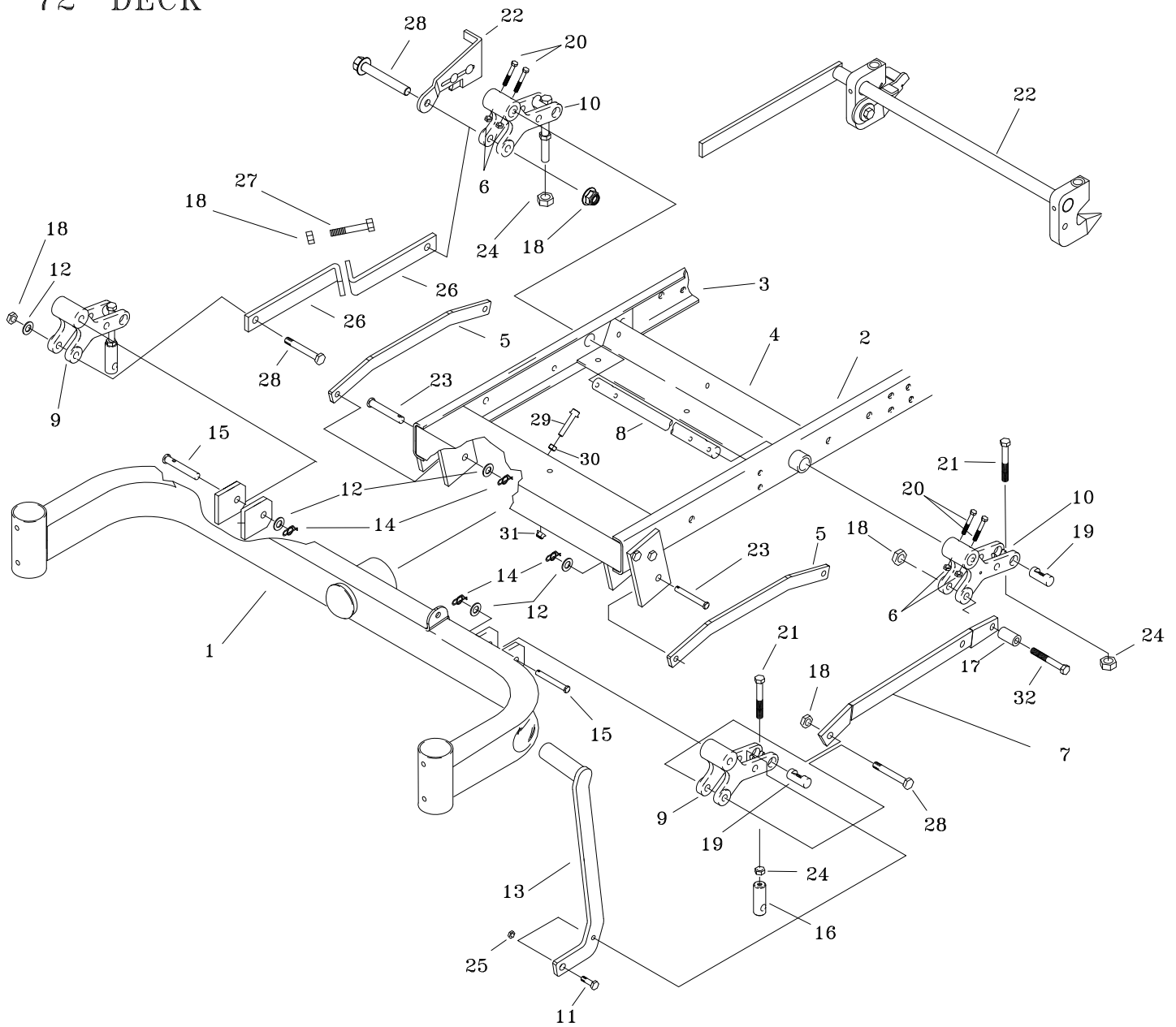

ITEM	PART #	QTY.	DESCRIPTION	ITEM	PART #	QTY.	DESCRIPTION
1	709-171W	1	WIDE FRONT AXLE WELDMENT	17	629-826P	1	SPACER
2	709-054W	1	FRAME SIDE WLDT, LH	18	F-2152	5	NUT, 1/2-13, NYLOC, FLANGED
3	709-055W	1	FRAME SIDE WLDT, RH	19	642-177P	2	HANGER PIN
4	709-157W	1	FRONT PIVOT CHANNEL	20	F-2039	4	5/16-24 x 2" HHCS BOLT
5	659-299P	2	LINK BAR	21	F-1936	4	1/2-13 X 3-1/2, 2" THREAD
6	F-2041	4	5/16-24 LOCKNUT	22	----	1	QRS SYSTEM, SEE PAGE #6
7	647-071P	1	DRAG BAR	23	F-1896	2	CLEVIS PIN, 1/2 X 1-3/4"
8	620-051P	1	LIFT BAR	24	F-1489	4	NUT, 1/2" JAM
9	642-081P	2	LIFT SLEEVE, FRONT	25	F-1125	1	5/16" LOCKNUT
10	642-193P	2	LIFT SLEEVE, REAR	26	647-144P	2	OFFSET LINK BAR ADJUSTABLE
11	F-1879	1	5/16-18 X 1-1/4" BOLT	27	F-2128	1	FHCS, 1/2-13 x 2", YZ, GR5
12	F-1521	6	WASHER, 1/2 NARROW	28	F-2163	3	FHCS, 1/2-13x3-1/2", YZ, GR5
13	629-249W	1	OFFSET DECK LIFT PEDAL	29	F-2126	1	FHCS, 3/8-16 x 2", YZ, GR5
14	H-2239	4	RUE RING, 1/2"	30	F-1011-03	1	NUT, 3/8-16
15	F-1890	2	CLEVIS PIN, 1/2 X 3-1/2"	31	F-2151	1	NUT, 3/8-16 NYLOC, FLANGED
16	642-175P	2	ADJUSTABLE HANGER END	32	F-2181	3	FHCS, 1/2-13x4-1/2", YZ, GR5

STEP & RELATED PARTS

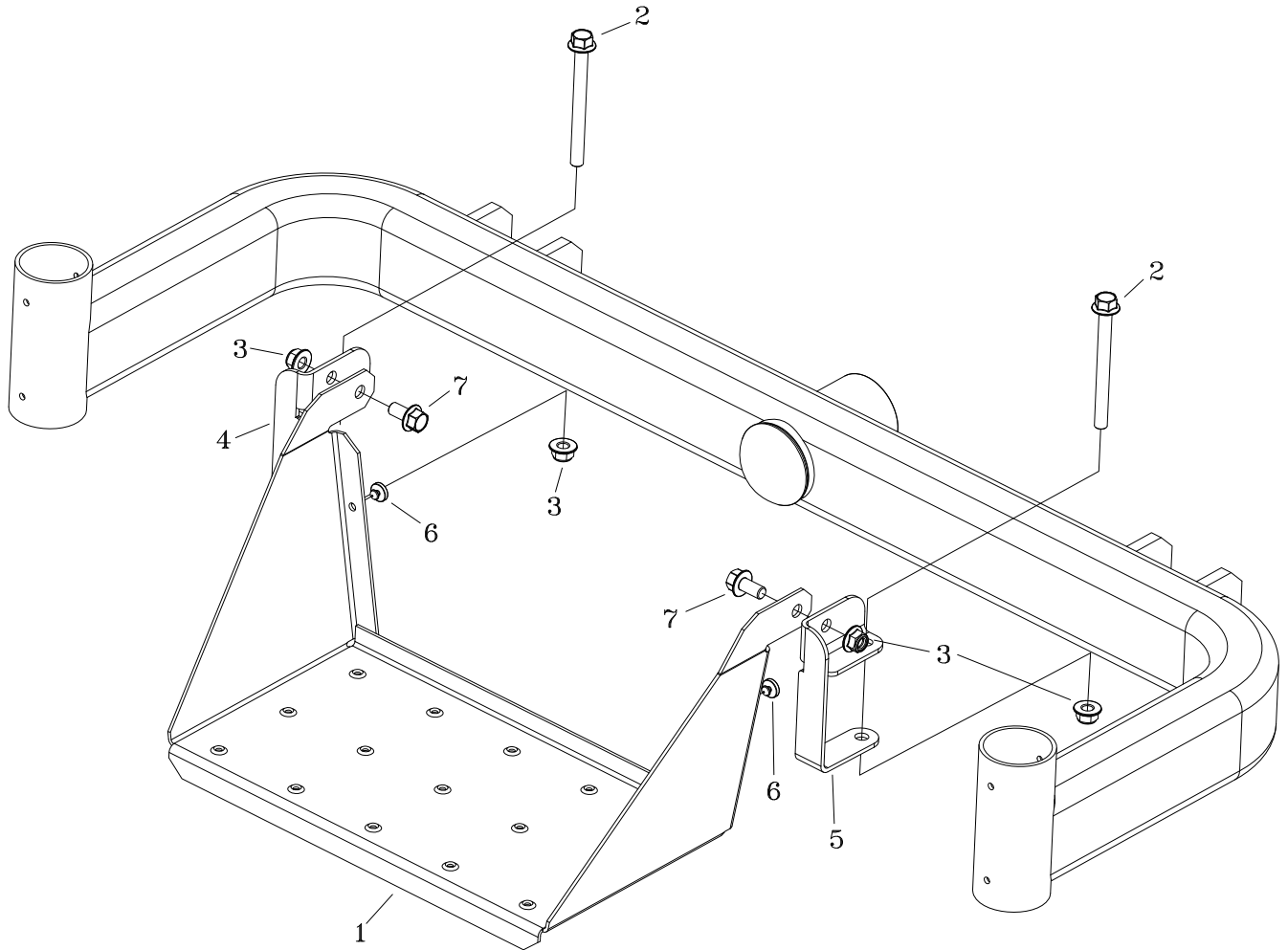

ITEM #	PART #	QTY	DESCRIPTION
1	663-134P	1	STEP, EXTENDED
2	F-2142	2	FHCS, 3/8-16x4", YZ, GR5 (60" ONLY)
3	F-2151	4	NUT, 3/8-16 NYLOC, FLANGED
4	659-241P	1	STEP MOUNT BRACKET, RH (60" ONLY)
5	659-242P	1	STEP MOUNT BRACKET, LH (60" ONLY)
6	H-2461	2	RUBBER BUMPER BUTTON
7	F-2124	2	FHCS, 3/8-16x3/4", YZ, GR5

DOUBLE IDLER & RELATED PARTS

NOTE:
MAKE SURE THAT BOLT #18 IS
IN PLACE BEFORE INSTALLING
PULLEYS #10 & #11.

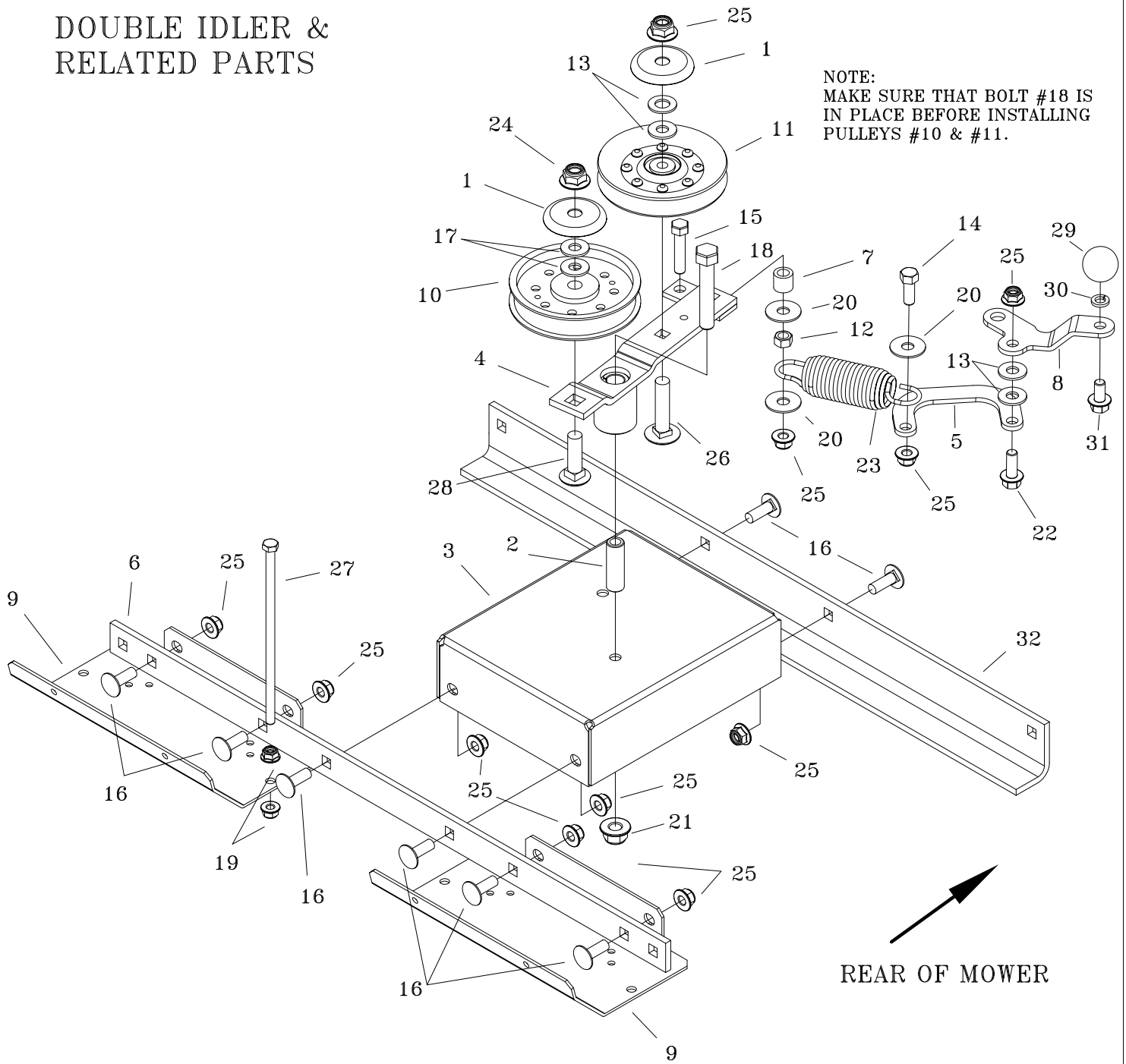

ITEM	PART #	QTY.	DESCRIPTION	ITEM	PART #	QTY.	DESCRIPTION
1	620-201P	2	WASHER, BEARING CAP	17	F-1521	2	1/2" WASHER, CUSTOM
2	709-224P	1	MOUNTING PIN	18	F-1439	1	HHCS, 1/2-13 X 3", YZ, GR5
3	709-225P	1	DECK DRIVE IDLER MOUNT	19	F-2063	2	NUT, 5/16-18 NYLOC, FLANGED
4	709-087A	1	IDLER ARM ASSEMBLY	20	F-2083	3	WASHER, 3/8 FENDER
5	709-088P	1	LINK, BELT TIGHTENING	21	F-2152	1	NUT, 1/2-13, NYLOC, FLANGED
6	709-091P	1	CROSS BRACE	22	F-2141	1	FHCS, 3/8-16 X 1", YZ, GR5
7	709-123P	1	SPACER, BELT TENSION	23	H-2619	1	SPRING, 5 x 1-1/2", TAPERED ENDS
8	709-177P	1	HANDLE, BELT TIGHTENER	24	F-2152	1	NUT, 1/2-13 NYLOC, FLANGED
9	709-126P	2	AIR DAM	25	F-2151	12	NUT, 3/8-16 NYLOC, FLANGED
10	D-3922	1	PULLEY, FLAT IDLER, 4.25 O.D.	26	F-1976	1	3/8-16 x 2" CARRIAGE BOLT
11	D-3923	1	PULLEY V-IDLER, 4.59 O.D.	27	F-2156	1	5/16-18 x 8-1/2" CAPSCREW
12	F-1005-03	1	3/8-16 STOVER NUT	28	F-1964	1	1/2-13 x 1-3/4" CARRIAGE BOLT
13	F-1009-03	5	3/8 FLAT WASHER	29	H-2405	1	BALL, 1-1/4", 3/8-16 THRD, BLK
14	F-1394	1	3/8-16 x 1" CAPSCREW	30	F-1019-03	1	LOCK WASHER, 3/8
15	F-1015-28	1	3/8-16 x 1-3/4" CAPSCREW	31	F-2124	1	FHCS, 3/8-16 x 3/4", YZ, GR5
16	F-1274	8	3/8-16 x 1" CARRIAGE BOLT	32	709-187P	1	CROSS BRACE

ANTI-ROTATING CASTER WHEEL & RELATED PARTS

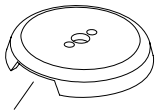

NOTE NOTCH:
TOWARDS REAR OF MOWER

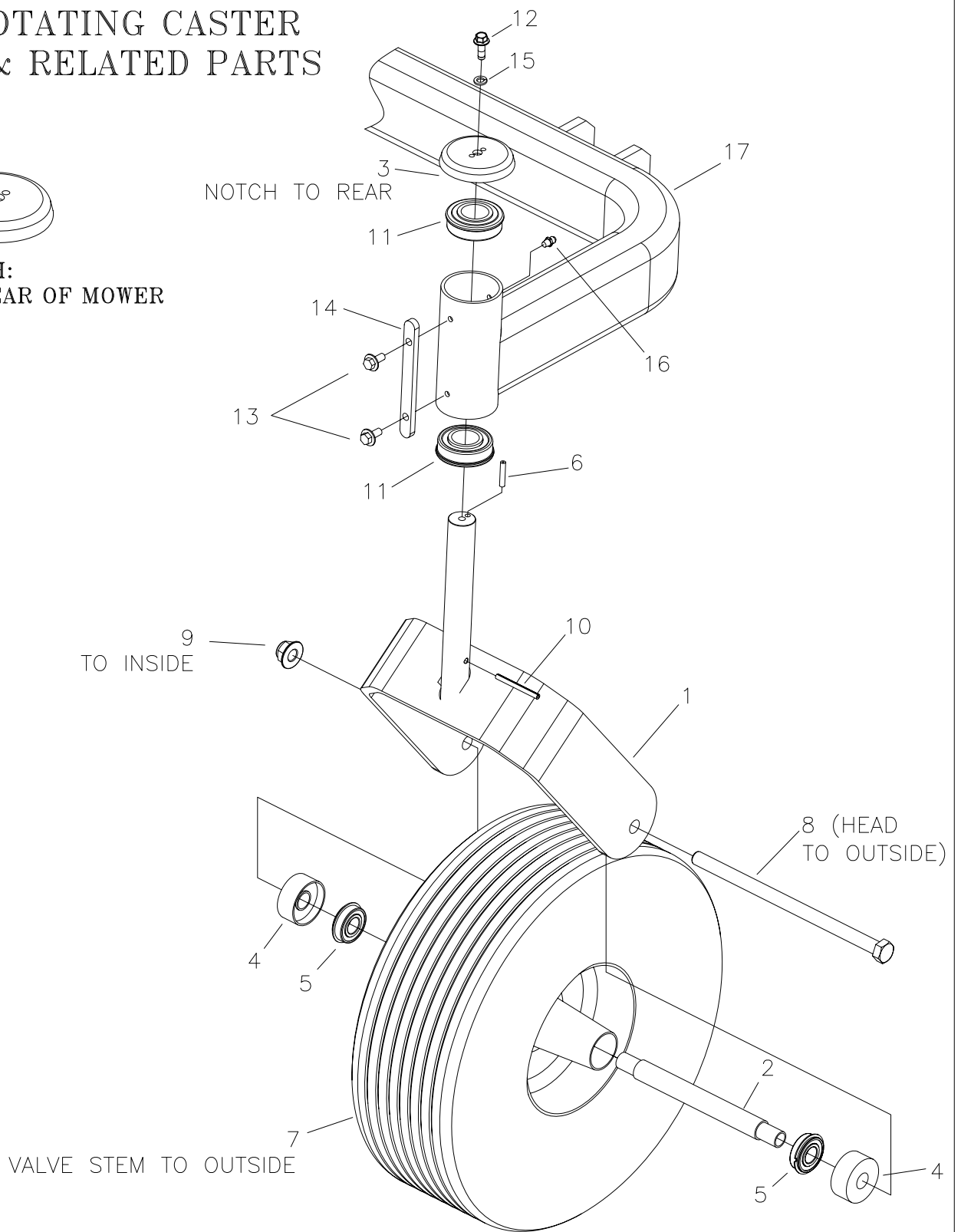

ITEM	PART #	QTY.	DESCRIPTION	ITEM	PART #	QTY.	DESCRIPTION
1	709-043W	1	CASTER WLDT	10	F-1456	1	3/16 x 2" SPIRAL PIN
2	647-038P	1	BEARING SPACER	11	D-2008-02	2	BEARING, SPD SF-16-32
3	636-177P	1	BEARING CAP	12	F-2121	1	FHCS, 5/16-18X3/4", LOCK PATCH
4	611-135P	2	BEARING SHIELD	13	F-2030	2	1/4" x 5/8" SELF TAPPING SCREW
5	D-3432	2	BEARING, 5/8 ID X 1-3/8 OD	14	659-187P	1	STOP TAB
6	F-1855	1	3/16 x 1" ROLL PIN	15	F-1019-02	1	LOCK WASAHER, 5/16
7	D-3893	1	TIRE, 15 X 6.00-6 (RIBBED)	16	H-1056	1	GREASE ZERK
8	F-2159	1	1/2-13 X 9-1/2" GR5	17	-----	1	FRONT AXLE WELDMENT (SEE pg.7 OR 8)
9	F-2152	1	NUT, 1/2-13 NYLOCK, GR5				

FRAME SIDES & RELATED PARTS

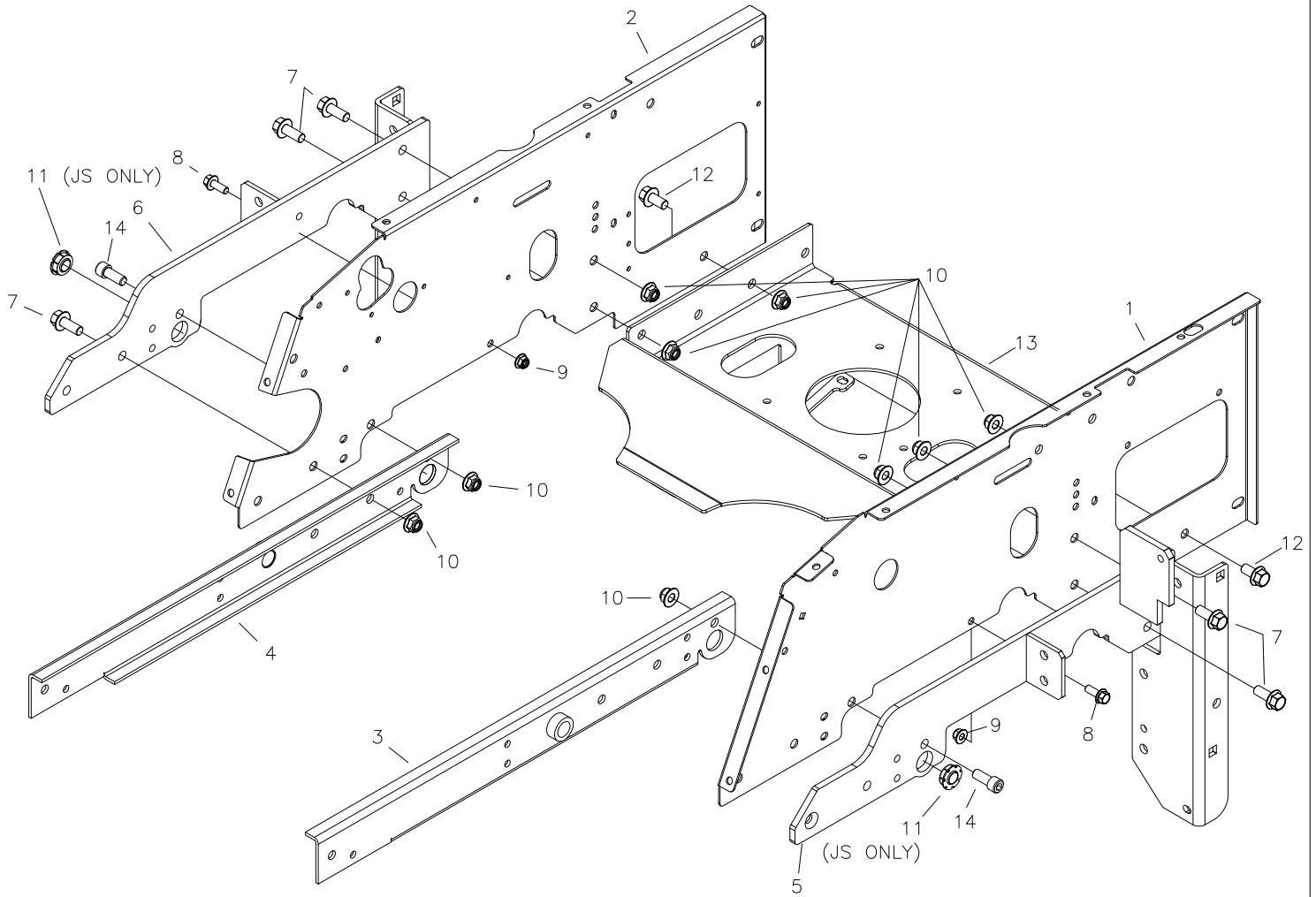

ITEM	PART #	QTY.	DESCRIPTION	ITEM	PART #	QTY.	DESCRIPTION
1	709-016P	1	SIDE PANEL, JS, LH	7	F-2127	5	FHCS, 1/2-13 X 1-1/4, YZ, GR5
-	709-056P	1	SIDE PANEL, TS, LH	8	F-2141	2	FHCS, 3/8-16 x 1", YZ, GR5
2	709-017P	1	SIDE PANEL, JS, RH	9	F-2151	2	NUT, 3/8-16 NYLOC, FLANGED
-	709-076P	1	SIDE PANEL, TS, RH	10	F-2152	9	NUT, 1/2-13 NYLOC, FLANGED
3	709-054W	1	FRAME SIDE WLDT LH	11	H-2773	2	BEARING, FLANGED-SPHERICAL, IGUS
4	709-055W	1	FRAME SIDE WLDT RH	12	F-2143	2	FHCS, 1/2-13x1", YZ, GR5
5	709-080W	1	SIDE PLATE WLDT LH	13	709-009W	1	MOTOR MOUNT WLDT
6	709-081W	1	SIDE PLATE WLDT RH	14	F-2227	2	SHCS, 1/2-13 X 1-1/4, ZINC

FRAME SIDES & RELATED PARTS (CON'T)

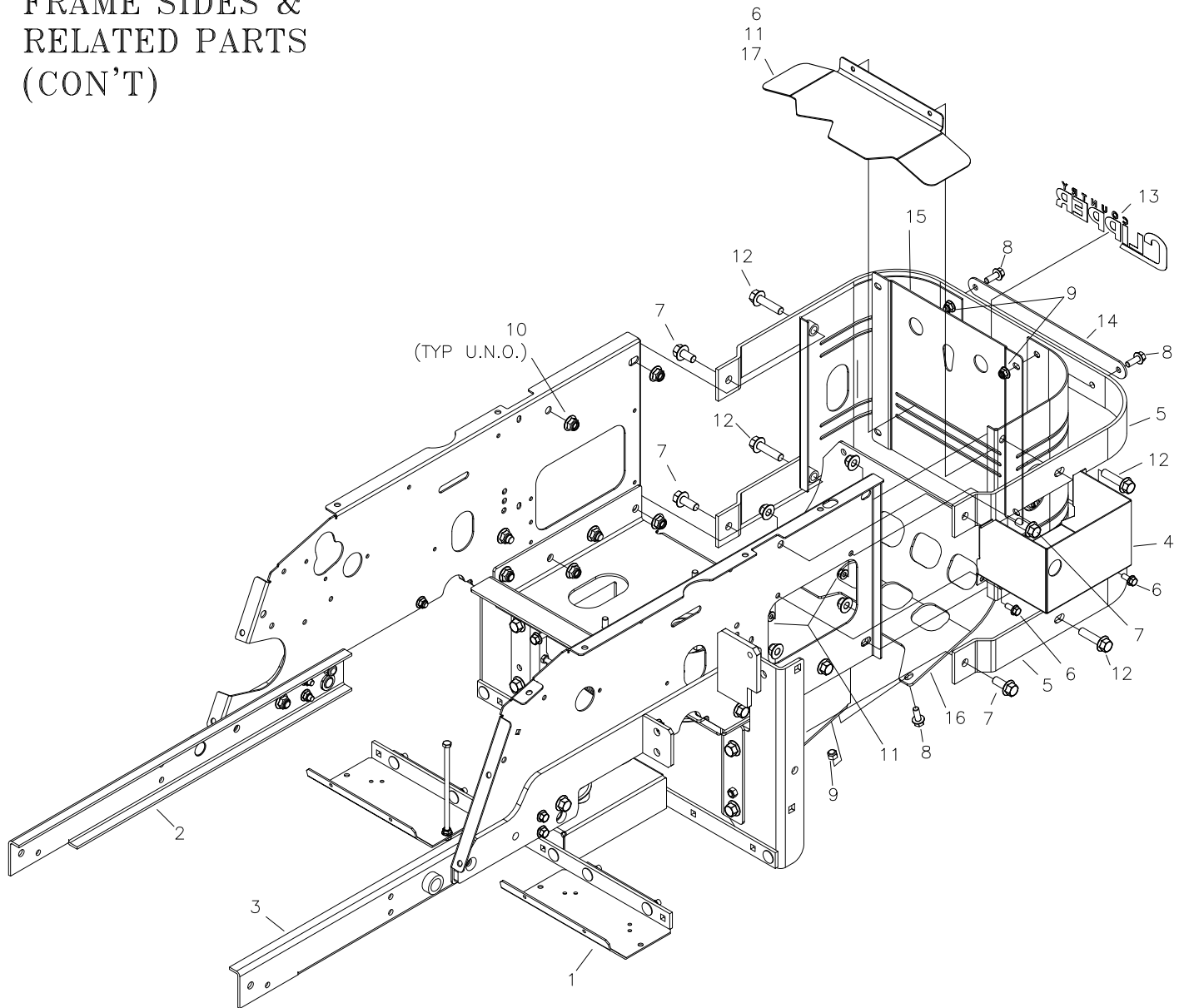

ITEM	PART #	QTY.	DESCRIPTION	ITEM	PART #	QTY.	DESCRIPTION
1	-----	1	DOUBLE IDLER MOUNT (SEE PG.10)	10	F-2152	8	NUT, 1/2-13 NYLOC, FLANGED
2	-----	1	FRAME SIDE (SEE PG.12)	11	F-2063	4	NUT, 5/16-18, NYLOC, FLANGED
3	-----	1	FRAME SIDE (SEE PG.12)	12	F-2128	2	FHCS, 1/2-13x2", YZ, GR5
4	709-022P	1	BATTERY MOUNT BOX	13	P-13312	1	DECAL, LOGO, CHROME w/BLK, LG
5	709-098P	2	BAR, REAR ENGINE GUARD	14	H-2912	1	PLACARD, BOSS XL
6	F-2120	4	FHCS, 5/16-18x3/4", YZ, GR5	15	629-895A	1	ENGINE GUARD, w/DECAL
7	F-2127	4	FHCS, 1/2-13x1-1/4", YZ, GR5	16	709-228P	1	PLATE, MUFFLER GUARD
8	F-2141	6	FHCS, 3/8-16 x 1", YZ, GR5	17	709-218P	1	HEAT SHIELD (KOHLER ONLY)
9	F-2151	6	NUT, 3/8-16 NYLOC, FLANGED				

FRAME SIDES & RELATED PARTS (CON'T)

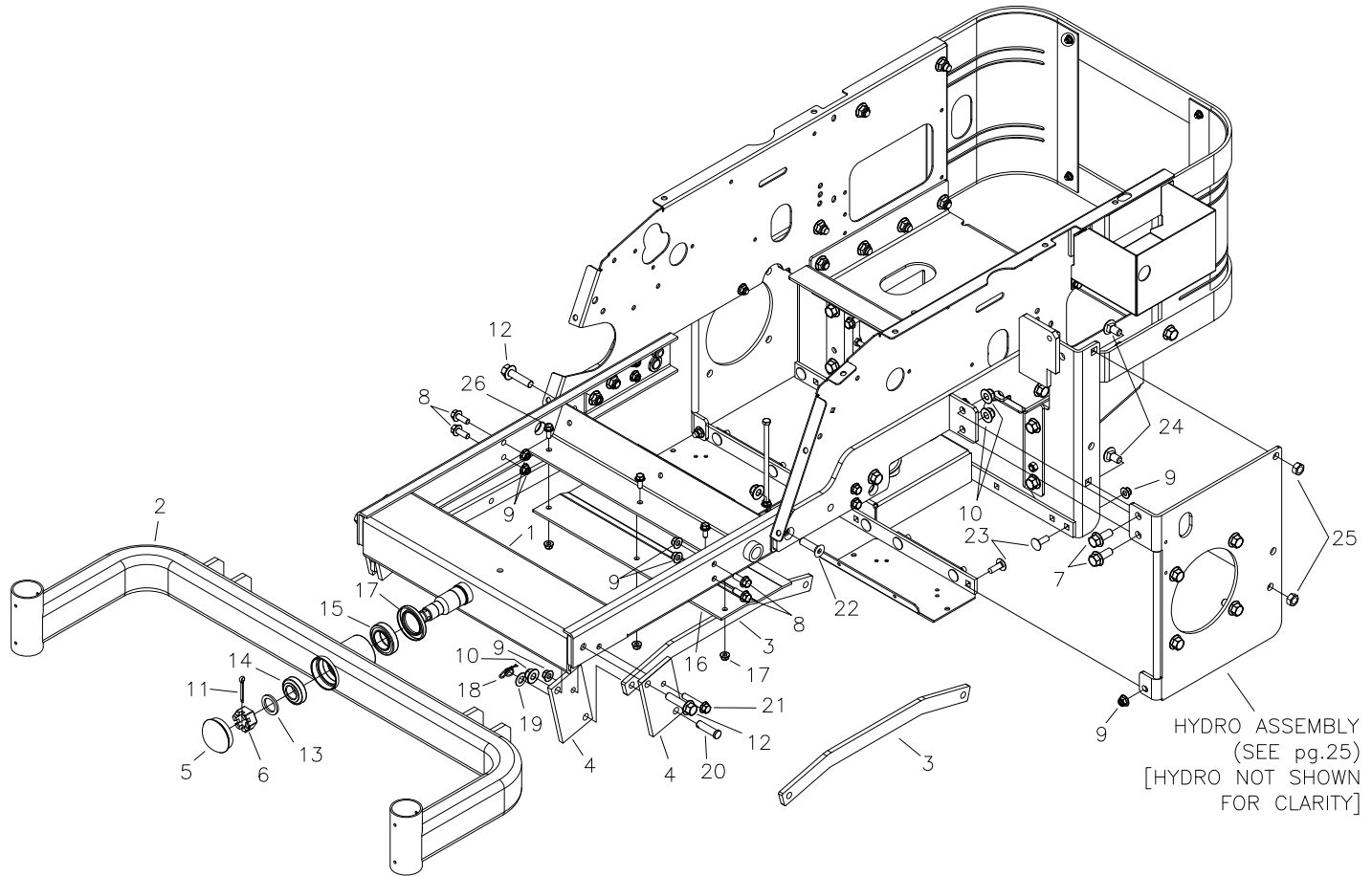

ITEM	PART #	QTY.	DESCRIPTION	ITEM	PART #	QTY.	DESCRIPTION
1	709-157W	1	FRONT PIVOT CHANNEL WLDT	14	D-3826	1	BRG, TAPERED, SET, L44643-L44610
2	642-189W	1	FRONT AXLE WLDT (60" DECK)	15	D-3825	1	BRG, TAPERED, SET, L68149-L68110
-	709-171W	1	FRONT AXLE WLDT (72" DECK)	16	709-100P	1	FUEL TANK SUPPORT
3	-----	-	LINK BAR (72" DECK, SEE pg.8)	17	H-2812	1	SEAL, SHAFT, 1.75x2.375x0.313
-	-----	-	LINK BAR (60" DECK, SEE pg.7)	18	H-2239	2	1/2" RUE RING
4	642-063P	4	DRAG BAR MOUNT TAB	19	F-1521	2	1/2' WASHER, CUSTOM
5	H-1924	1	GREASE CAP	20	F-1896	2	1/2" x 1-3/4", CLEVIS PIN
6	F-1724	1	SLOTTED HEX NUT, 1"-14	21	F-2126	2	FHCS, 3/8-16 x 2", YZ, GR5
7	F-2127	2	FHCS, 1/2-13x1-1/4", YZ, GR5	22	F-2149	1	HEX SCK FLT HD CAP, 1/2-13x1-3/4"
8	F-2141	4	FHCS, 3/8-16 x 1", YZ, GR5	23	F-1274	2	CARRIAGE BOLT, 3/8-16 x 1"
9	F-2151	7	NUT, 3/8-16 NYLOC, FLANGED	24	F-2146	2	CARRIAGE BOLT, 1/2-13 x 1"
10	F-2152	4	NUT, 1/2-13 NYLOC, FLANGED	25	F-1005-05	2	1/2-13 STOVER NUT
11	F-1728	1	3/16" x 2" COTTER PIN	26	F-2120	3	FHCS, 5/16-18 x 3/4", YZ, GR5
12	F-2128	2	FHCS, 1/2-13x2", YZ, GR5	27	F-2063	3	NUT, 5/16-18 NYLOC, FLANGED
13	606-303P	1	1" WASHER				

FENDER ASSEMBLY

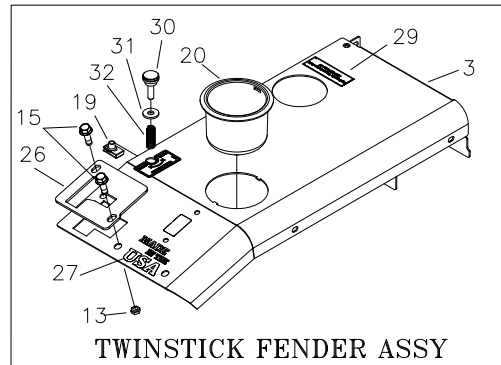
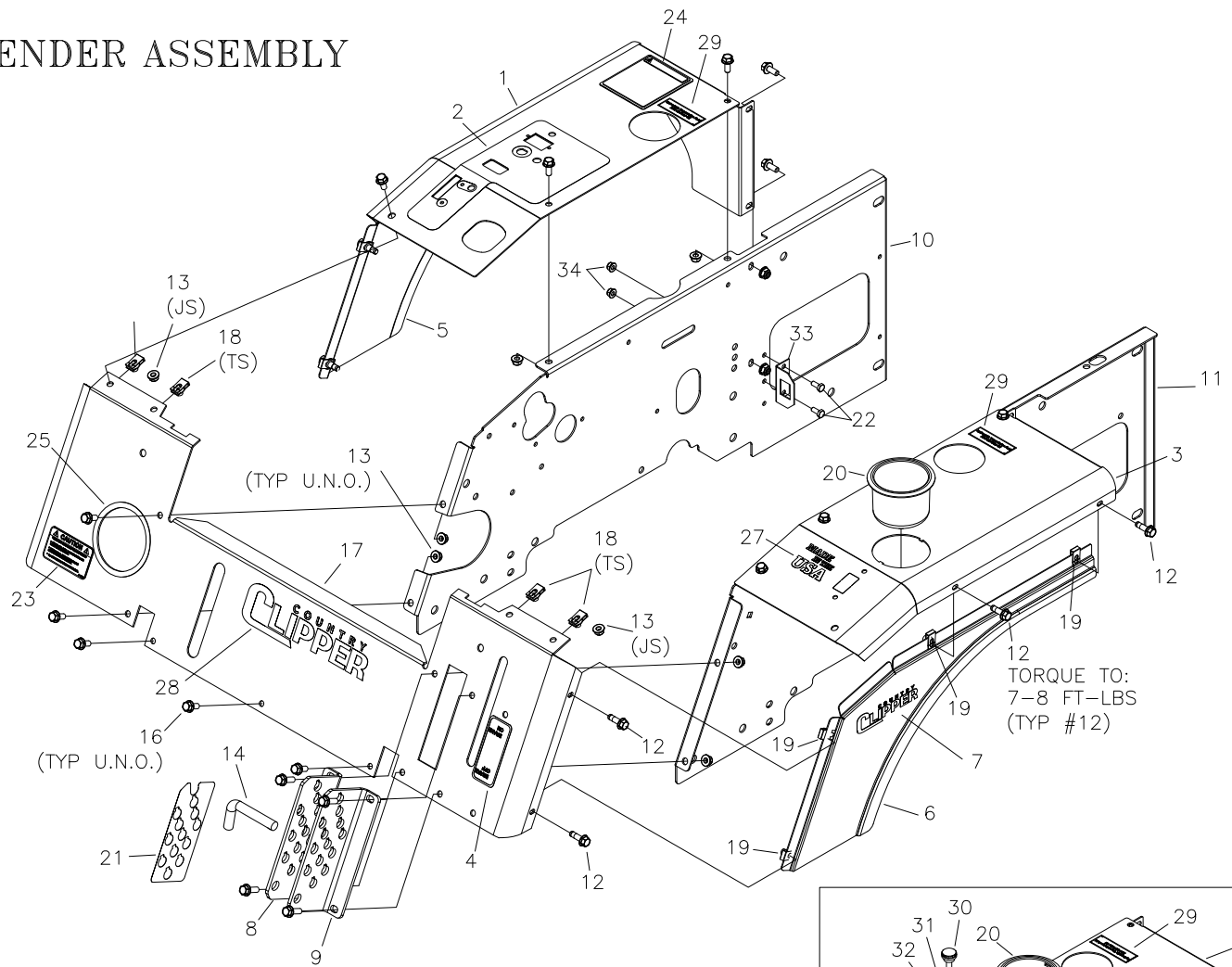

ITEM	PART #	QTY.	DESCRIPTION	ITEM	PART #	QTY.	DESCRIPTION
1	625-157A	1	FENDER CAP w/DECAL, RH, (JS)	16	F-2120	17	FHCS, 5/16-18 X 3/4" GR.5
-	625-159A	1	FENDER CAP w/DECAL, RH, (TS)	17	709-220A	1	FRONT PANEL w/DECALS
-	625-165A	1	FENDER CAP, EFI w/DECAL, RH, (TS)	18	F-1860	4	5/16-18 "U"-NUT
2	P-11369	1	DECAL, CONTROL PANEL (JS)	19	F-1858	8	1/4-20 "U"-NUT
-	P-12682	1	DECAL, CONTROL PANEL (TS)	20	H-2228	1	CUP HOLDER
3	625-158A	1	FENDER CAP w/DECAL, LH (JS)	21	P-13325	1	DECAL, DECK LIFT
-	625-160A	1	FENDER CAP w/DECAL, LH (TS)	22	F-1015-02	2	CAPSCREW, 1/4-20 x 5/8"
4	P-11382	1	DECAL, PARK BRAKE	23	P-12557	1	DECAL, "CAUTION"
5	629-897A	1	FENDER SKIRT w/DECAL, RH	24	P-11370	1	DECAL, WARNING
6	629-898A	1	FENDER SKIRT w/DECAL, LH	25	H-1626	1	U CHANNEL TRIM
7	P-13311	2	DECAL, LOGO, CHROME w/BLK, SM	26	659-262P	2	NEUTRAL PLATE
8	647-259A	1	LATCH PLATE RH W/DECAL	27	P-13000	1	DECAL, "USA"
9	647-258P	1	LATCH PLATE LH.	28	P-13312	1	DECAL, LOGO, CHROME w/BLK, LG
10	-----	1	SEE PAGE 12	29	P-11052	2	HYDRO FLUID DECAL
11	-----	1	SEE PAGE 12	30	F-2081	2	KNOB, 5/16-18x1", 7/8" DIA HEAD
12	F-2119	8	FHCS, 1/4-20x3/4", GR.5 w/PATCH	31	F-1009-02	2	5/16" FLAT WASHER
13	F-2063	20	FLANGED NUT, 5-16-18, NYLOC	32	H-1776	2	SPRING, COMP .48 x .0445 x 1.25
14	H-3013	1	DECK HEIGHT PIN	33	647-146P	1	FUSE HOLDER
15	F-2121	4	FHCS, 5/16-18x1" GR.5 w/PATCH	34	F-2132	2	NUT, 1/4-20 NYLOC, FLANGED

SEAT FRAMING & RELATED PARTS

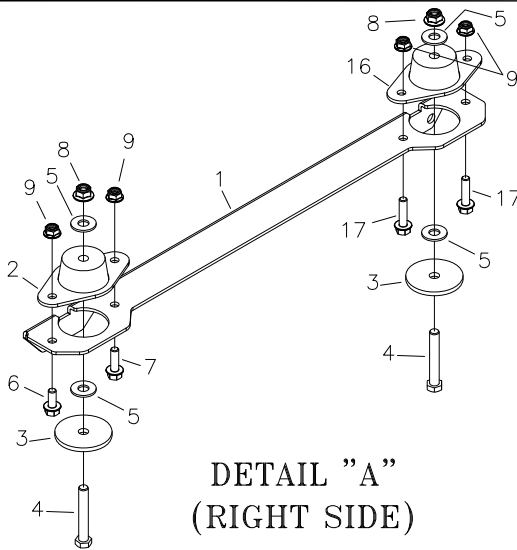
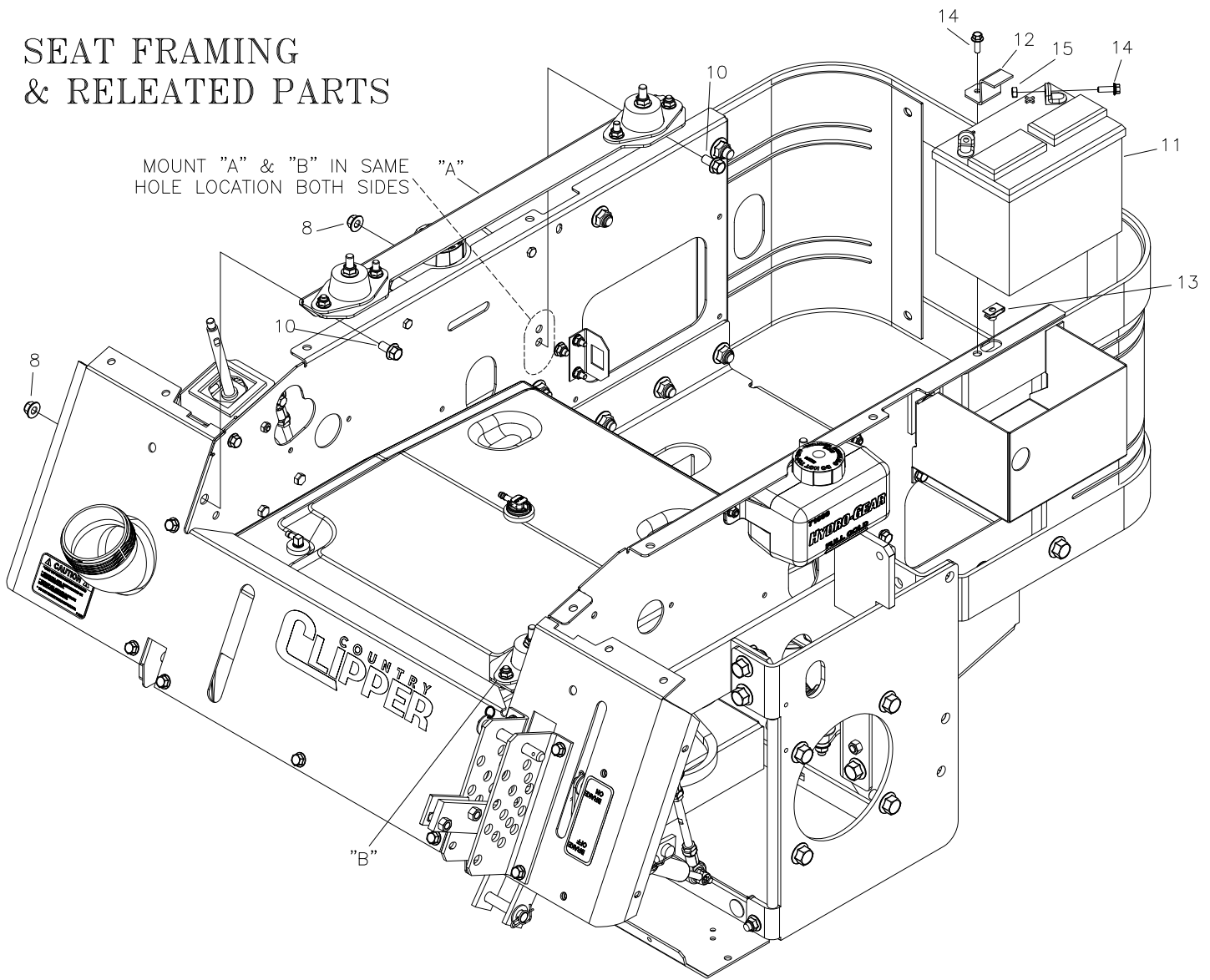

**DETAIL "A"
(RIGHT SIDE)**

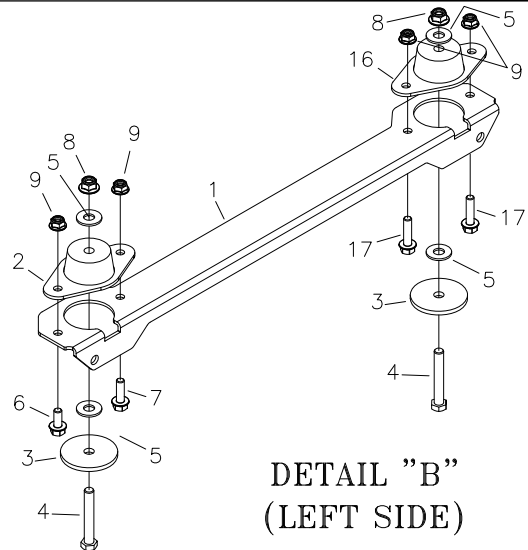

**DETAIL "B"
(LEFT SIDE)**

ITEM	PART #	QTY.	DESCRIPTION	ITEM	PART #	QTY.	DESCRIPTION
1	709-020P	2	SEAT MOUNT ANGLE	10	F-2124	4	FHCS, 3/8-16 x 3/4", YZ, GR5
2	H-2734	2	ISOLATOR, VIBRATION	11	E-6271	1	12 VOLT BATTERY, YSP 40 AMP
3	F-2102	4	WASHER .406 I.D.x2.25 O.D.x7GA	12	709-097P	1	BATTERY HOLD DOWN
4	F-1542	4	CAPSCREW, 3/8-16 X 2 3/4	13	F-1858	1	1/4-20 "U"-NUT
5	F-1009-03	8	3/8" FLAT WASHER	14	F-2162	3	FHCS, 1/4-20 x 3/4", YZ, GR5
6	F-2120	2	FHCS, 5/16-18 x 3/4", YZ, GR5	15	F-1158	2	1/4-20 STOVER NUT
7	F-2148	6	FHCS, 5/16-18 x 1", YZ, GR5	16	H-2830	2	ISOLATOR, VIBRATION
8	F-2151	4	NUT, 3/8-16 NYLOC, FLANGED	17	F-2122	4	FHCS, 5/16-18x1-1/4", YZ, GR5
9	F-2063	8	NUT, 5/16-18 NYLOC, FLANGED				

SEAT FRAMING & RELEATED PARTS (CON'T)

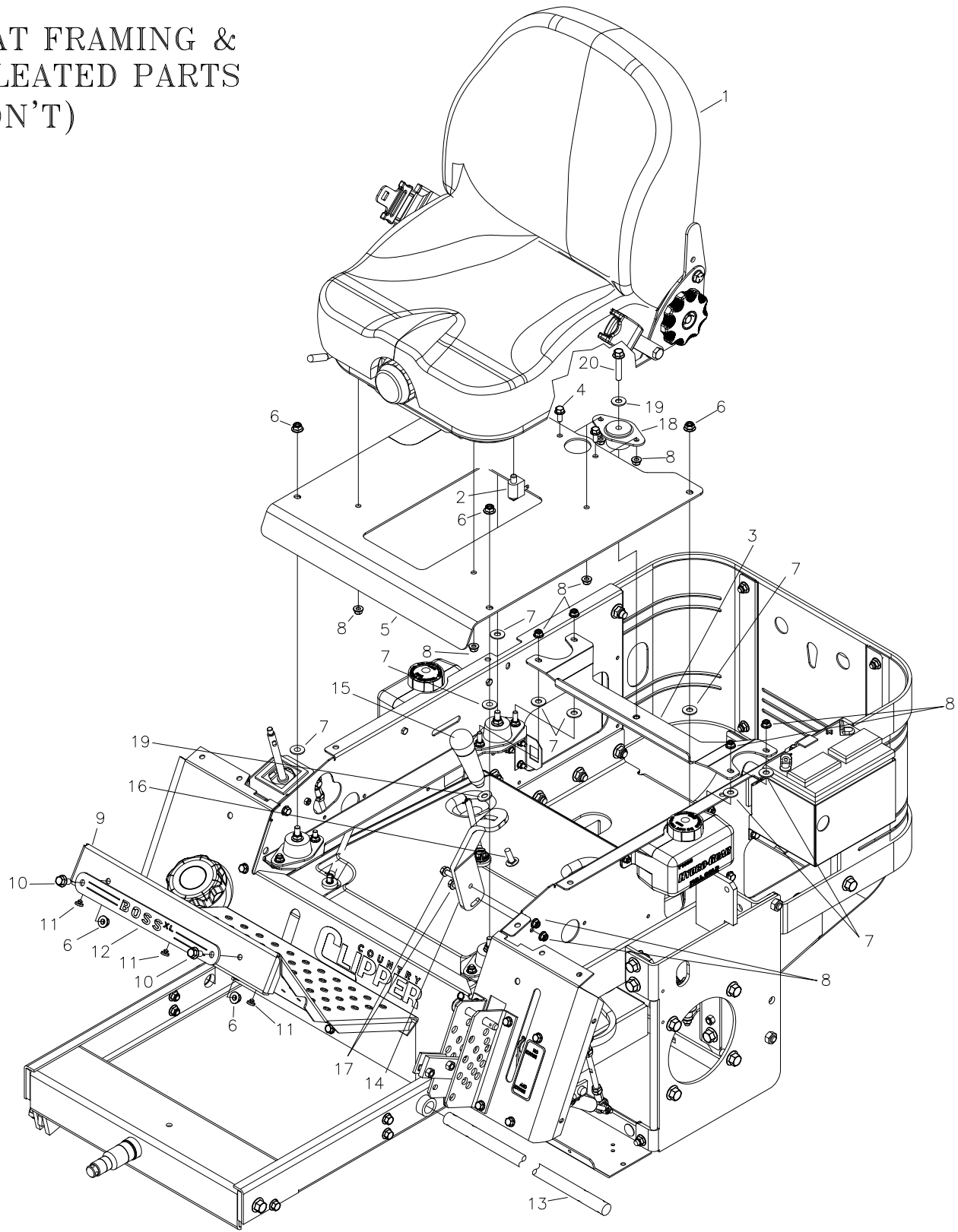

ITEM	PART #	QTY.	DESCRIPTION	ITEM	PART #	QTY.	DESCRIPTION
1	H-2788	1	SEAT	11	H-2461	3	RUBBER BUMPER
-	H-2916	1	COVER FOR SEAT H-2788	12	H-2912	1	PLACARD, BOSS XL
2	E-6580	1	SEAT SWITCH	13	620-051P	1	LIFT BAR
3	709-160P	1	CHANNEL, REAR SEAT PAN	14	709-107P	1	BAR, SECURITY HANDLE MOUNT
4	F-2120	1	FHCS, 5/16-18 x 3/4", YZ, GR5	15	H-2764	1	HANDLE, JOYSTICK
5	709-021P	1	SEAT PAN	16	F-1274	1	CARRIAGE BOLT, 3/8-16 x 1"
6	F-2151	6	NUT, 3/8-16 NYLOC, FLANGED	17	F-2148	1	FHCS, 5/16-18 x 1", YZ, GR5
7	F-1009-02	8	5/16" FLAT WASHER	18	H-2830	1	ISOLATOR, VIBRATION
8	F-2063	12	NUT, 5/16-18 NYLOC, FLANGED	19	F-1009-03	1	3/8" FLAT WASHER
9	663-208P	1	FOOT DECK	20	F-2126	1	FHCS, 3/8-16 x 2", YZ, GR5
10	F-2124	2	FHCS, 3/8-16 x 3/4", YZ, GR5				

R.O.P.S. ASSEMBLY & RELATED PARTS {H-2914}

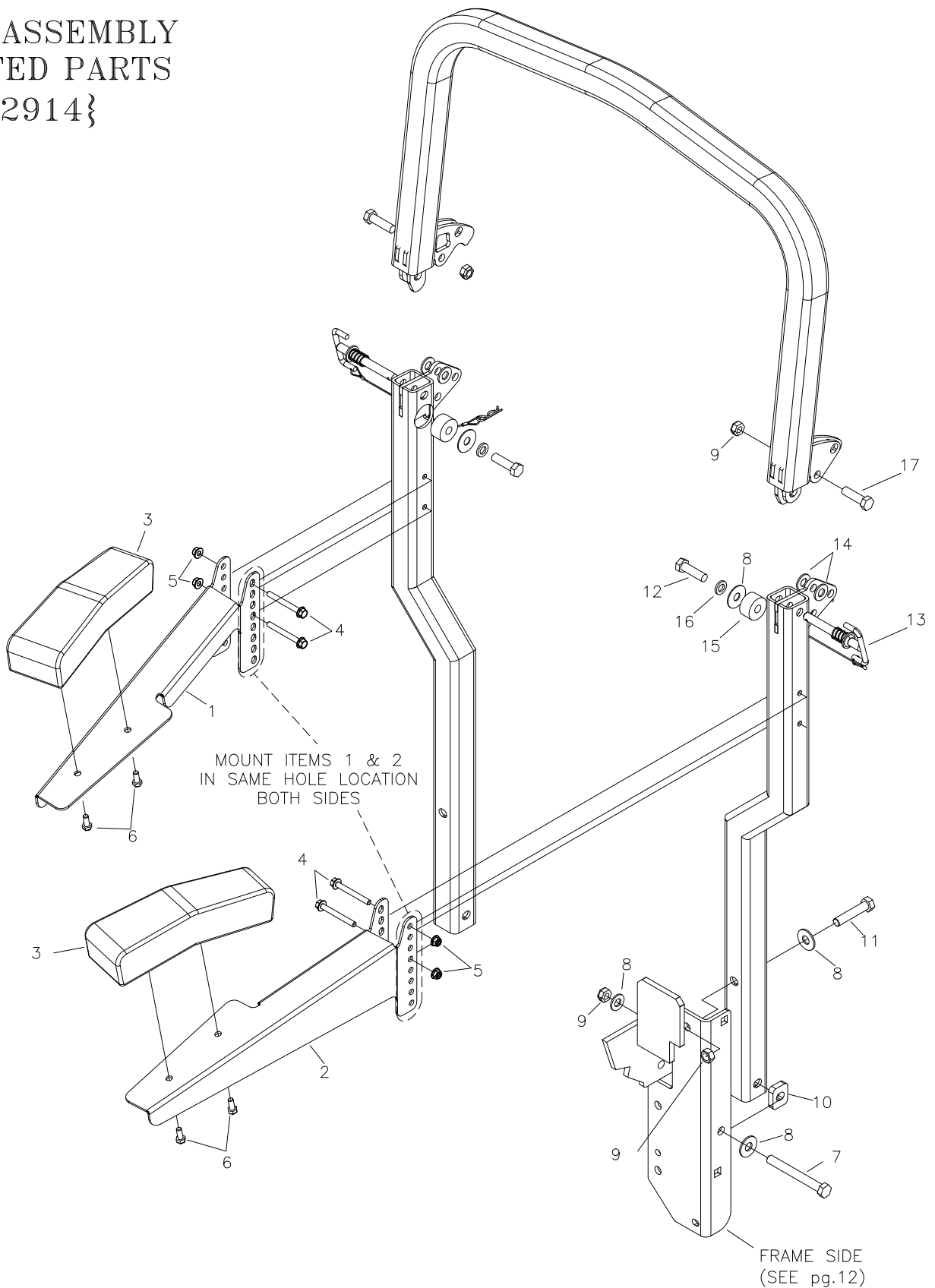

ITEM	PART #	QTY.	DESCRIPTION	ITEM	PART #	QTY.	DESCRIPTION
1	709-178P	1	ARM REST, RH	10	H-2826	2	PLATE, LOWER SPACER
2	709-179P	1	ARM REST, LH	11	F-2168	2	HHCS, 1/2-13 X 3", GR.5
3	H-2799	2	PAD, ARM REST	12	F-2211	2	HHCS, 1/2-13 X 1.75", GR.5
4	F-2153	4	FHCS, 5/16-18 X 2-3/4", YZ, GR.5	13	F-2208	2	PULL PIN ASS'Y, Ø1/2 T-HANDLE
5	F-2063	4	NUT, 5/16-18 NYLOC, FLANGED	14	F-2213	4	FW, Ø1/2 SAE
6	F-2120	4	FHCS, 5/16-18 X 3/4", YZ, GR.5	15	F-2209	2	POLYURETHANE CYLINDER
7	F-2167	2	HHCS, 1/2-13 X 3-1/2", GR.5	16	F-2210	2	LW, Ø1/2
8	F-2170	8	FW, Ø1/2	17	F-2212	2	HHCS, 1/2-13 X 2.00", GR.5
9	F-2090	6	TOP LOCK NUT, 1/2-13 GR.C				

FUEL TANK ASSEMBLY H-2945

(ALL PARTS EXCEPT #7-11)

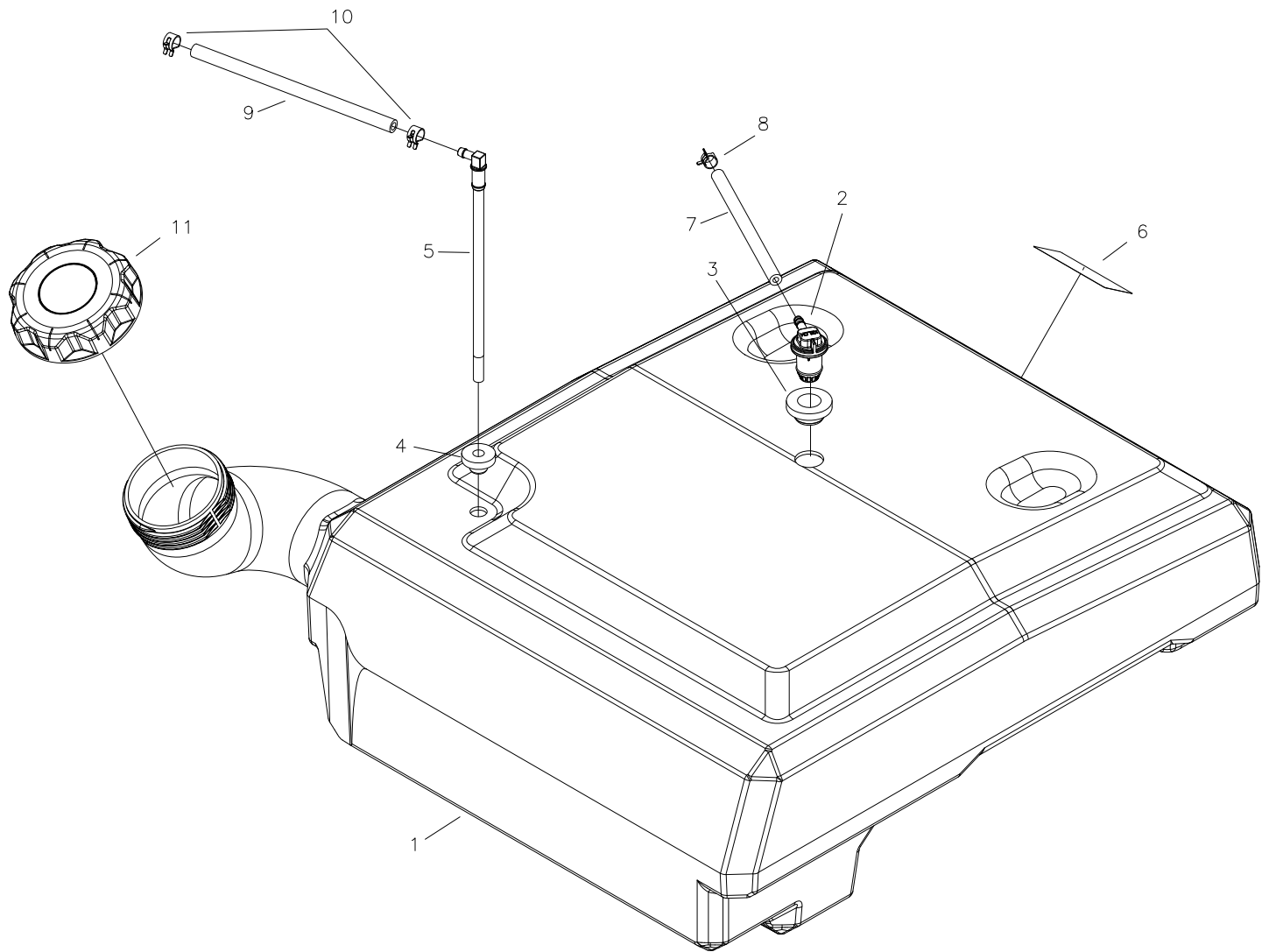

ITEM	PART #	QTY.	DESCRIPTION	ITEM	PART #	QTY.	DESCRIPTION
1	-----	1	FUEL TANK, ASS'Y	7	H-2697	2.59	HOSE, FUEL, .188" I.D.x.406" O.D.
2	H-2831	1	KELCH REMOTE VENT	8	H-2698	1	CLAMP, .406" O.D. FUEL LINE
3	H-2679	1	KELCH REMOTE VENT GROMMET	9	H-1648	5	HOSE, FUEL, 1/4" I.D.x1/2" O.D.
4	H-2741	1	GROMMET, PICK UP TUBE	10	H-1687	2	CLAMP, 1/2" O.D. FUEL LINE
5	H-2742	1	PICK UP TUBE	11	H-2743	1	RATCHET CAP w/TETHER, 3.5 DIA
6	P-12922	1	CARB/EPA LABEL				

JOYSTICK & RELATED PARTS (RIGHT SIDE)

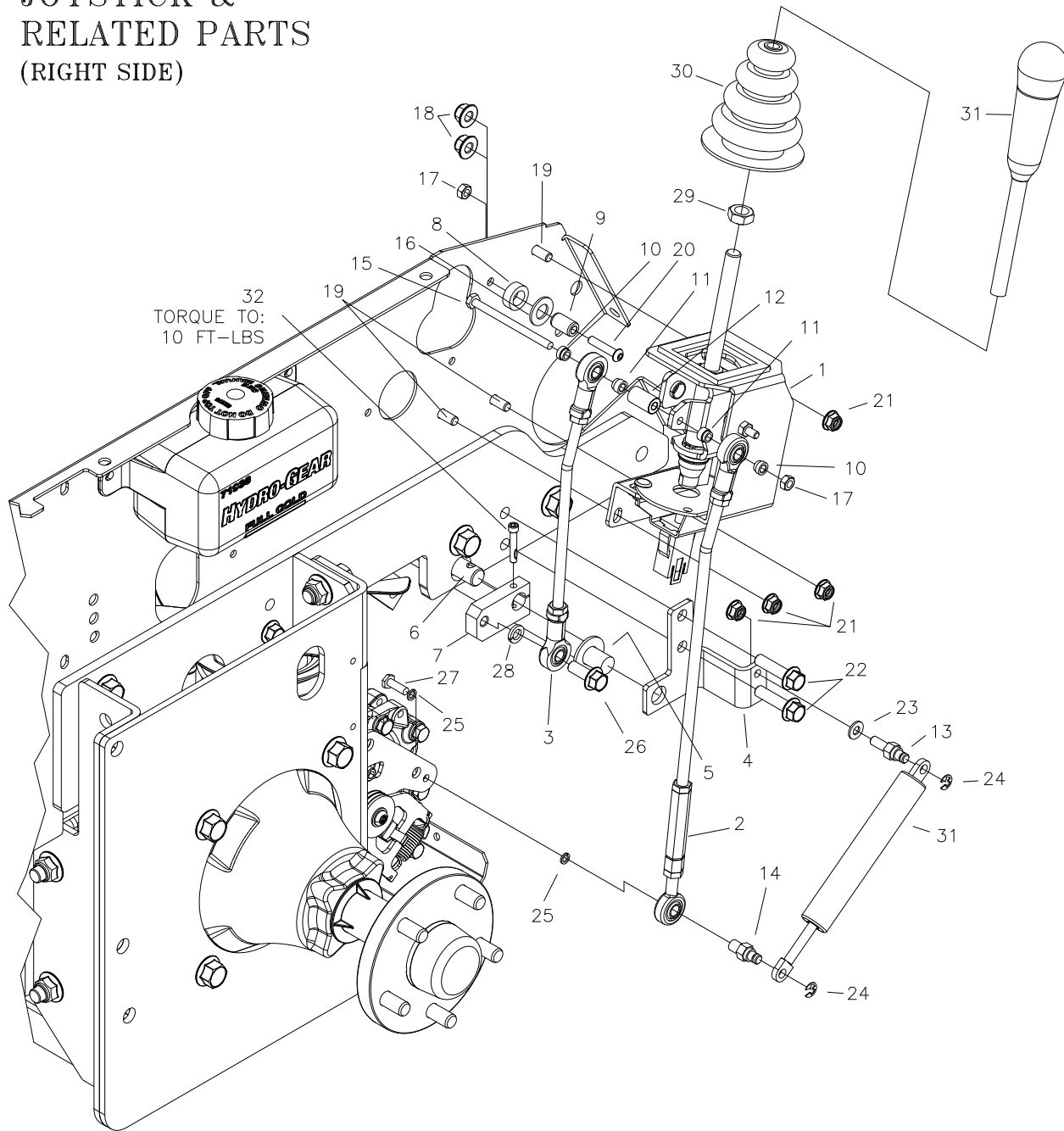

ITEM	PART #	QTY.	DESCRIPTION	ITEM	PART #	QTY.	DESCRIPTION
1	625-172A	1	JOYSTICK ASSEMBLY	17	F-1005-01	2	1/4-20 LOCK NUT
2	709-131P	1	LINKAGE, OUTER, JS	18	F-2151	2	NUT, 3/8-16 NYLOC, FLANGED
3	709-132P	1	LINKAGE, INNER, JS	19	F-2120	3	FHCS, 5/16-18 x 3/4", YZ, GR5
4	709-083P	1	BRACKET-ANCHOR, DAMPER	20	F-2103	1	BUTTON SHCS, 1/4-20 x 1", CZ
5	709-116W	1	BRAKE ROD WLDT	21	F-2063	4	NUT, 5/16-18 NYLOC, FLANGED
6	709-229P	1	HYDRO SHIFT ROD	22	F-2147	2	FHCS, 3/8-16x1-1/2", YZ, GR5
7	700-151P	1	ARM, SWIVEL, S/A	23	F-1009-01	1	1/4" FLAT WASHER
8	625-126P	1	SPACER JOYSTICK, PANEL	24	F-1610	2	E-RING FOR 1/4" SHAFT
9	625-119P	1	PIN, PIVOT, JS, LONG	25	F-1019-01	2	1/4" LOCKWASHER
10	625-116P	2	BUSHING, .375 ROD END, SHORT	26	F-2141	1	FHCS, 3/8-16 x 1", YZ, GR5
11	625-107P	2	BUSHING, .375 ROD END, LONG	27	F-1015-03	1	1/4-20 x 3/4", CAPSCREW
12	625-100P	1	TUBE, PIVOT, JOYSTICK	28	F-1019-03	1	3/8" LOCKWASHER
13	638-028P	1	DAMPER BOLT	29	F-1462	1	1/2-20 HEX JAM NUT
14	663-051P	1	DAMPER STUD	30	H-1991	1	BOOT
15	F-1020-01	1	1/4-20 x 3-1/2" CAPSCREW	31	709-168A	1	EXTENSION ASSEMBLY
16	F-1521	1	1/2" WASHER, CUSTOM	32	F-2231	1	SHCS, 12-24 X 1-1/4, ZINC, LOCK PATCH

JOYSTICK & RELATED PARTS (LEFT SIDE)

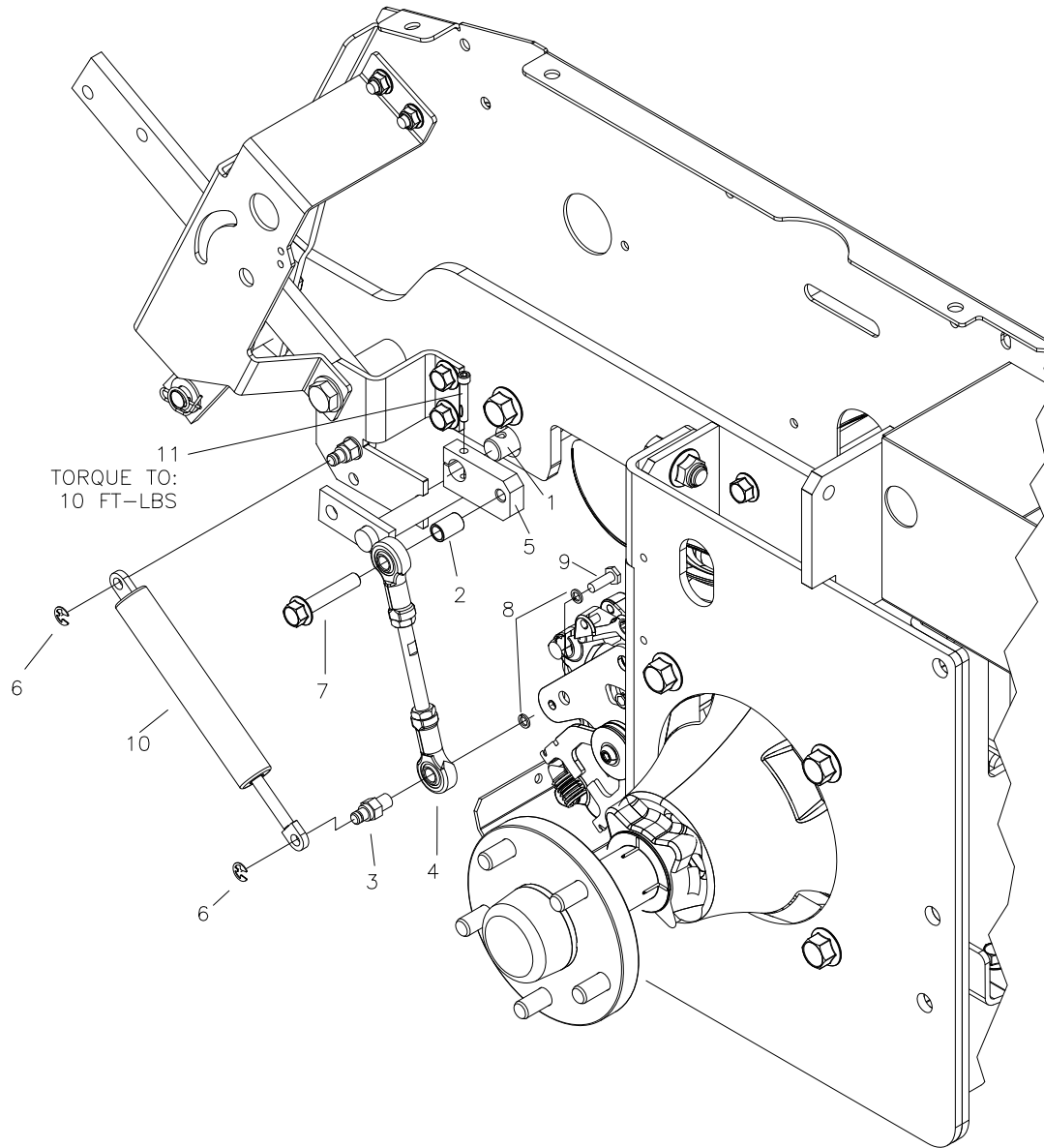

ITEM	PART #	QTY.	DESCRIPTION	ITEM	PART #	QTY.	DESCRIPTION
1	709-229P	1	HYDRO SHIFT ROD	7	F-2126	1	FHCS, 3/8-16 x 2", YZ, GR5
2	707-073P	1	STAND-OFF, LINKAGE MOUNT	8	F-1019-01	2	1/4" LOCKWASHER
3	663-051P	1	DAMPER STUD	9	F-1015-03	1	1/4-20 x 3/4" CAPSCREW
4	H-2468	1	LINKAGE ROD	10	H-2467	1	DUAL ACTION DAMPER
5	700-151P	1	ARM, SWIVEL, S/A	11	F-2231	1	SHCS, 12-24 X 1-1/4, ZINC. LOCK PATCH
6	F-1610	2	E-RING FOR 1/4" SHAFT				

JOYSTICK ASSEMBLY 625-172A

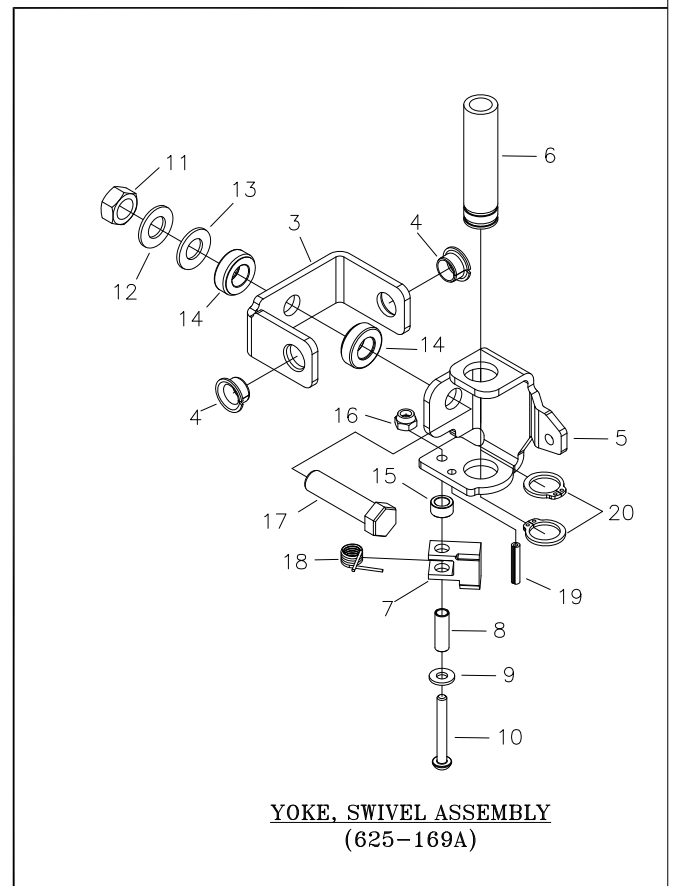
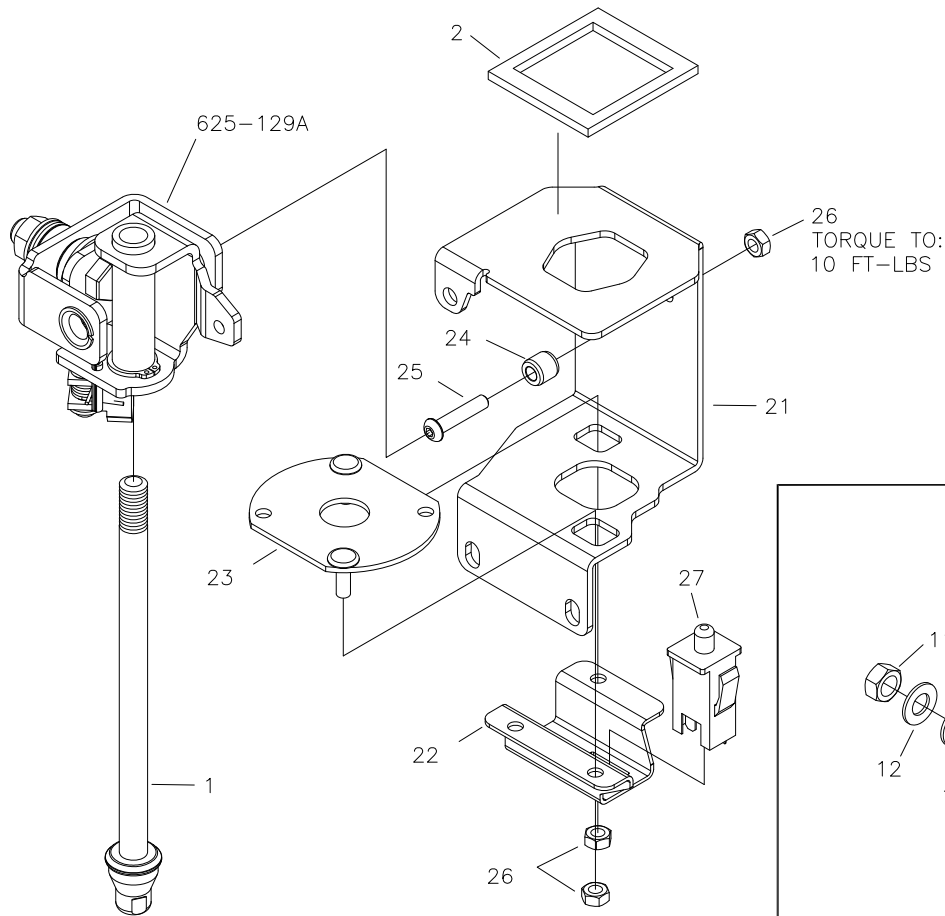

**YOKE, SWIVEL ASSEMBLY
(625-169A)**

ITEM	PART #	QTY.	DESCRIPTION	ITEM	PART #	QTY.	DESCRIPTION
1	709-169A	1	ROD ASSEMBLY	15	625-125P	1	SPACER, CAM DETENT
2	H-1947	1	GASKET, FOAM, JOYSTICK	16	F-2137	1	NUT, #12-24, NYLOCK
3	625-097P	1	PIVOT, JOYSTICK (PART OF 625-128A)	17	F-1293	1	1/2-13 x 2" CAPSCREW
4	D-3784	2	BUSHING, FLANGED (PART OF 625-128A)	18	H-2710	1	SPRING, DETENT, JOYSTICK
5	625-096P	1	YOKE, SWIVEL, JOYSTICK	19	F-1503	1	3/16 x 1" SPIRAL PIN
6	625-099P	1	TUBE, GUIDE, CONTROL ROD	20	H-2705	2	RING, DETENT, .75 EXT.
7	625-103P	1	TAB, CAM DETENT	21	625-154P	1	HOUSING, JOYSTICK
8	625-124P	1	TUBE-SPACER, DETENT CAM	22	659-285P	1	MOUNT, SWITCH
9	F-2136	1	WASHER, FLAT, #12 PLAIN	23	625-127W	1	NEUTRAL PLATE, WLDT
10	F-2135	1	SCR, PANHD, PHLPS, #12-24x1-3/4"	24	625-106P	1	PIN, PIVOT, JOYSTICK
11	F-1005-05	1	1/2-13 STOVER NUT	25	F-2103	1	BUTTON SHCS, 1/4-20 x 1", CZ
12	F-1521	1	1/2" WASHER, CUSTOM	26	F-1005-01	3	1/4-20 LOCK NUT
13	H-2704	1	SPRING, BELLEVILLE, .50x1x.073	27	E-6474	1	SWITCH, SNAP MOUNT
14	D-3931	2	THRUST BEARING				

TWINSTICK & RELATED PARTS

(RIGHT SIDE SHOWN, LEFTHAND OPPOSITE)

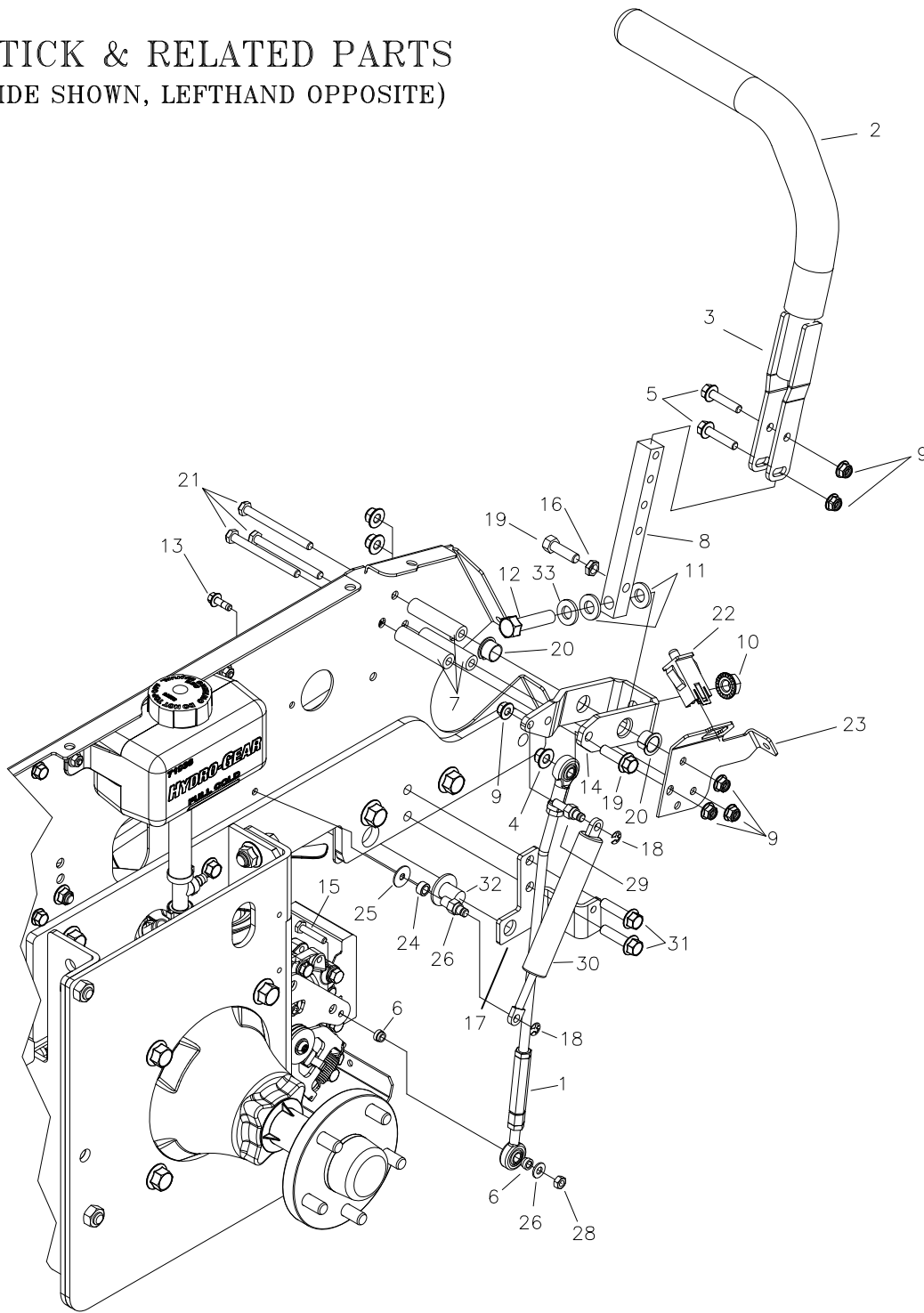

ITEM	PART #	QTY.	DESCRIPTION	ITEM	PART #	QTY.	DESCRIPTION
1	H-2794	1	LINKAGE, OUTER	18	F-1610	2	E-RING FOR 1/4" SHAFT
2	H-2739	1	GRIP, 15", CLOSED END	19	F-1307	2	3/8-16 X 1 1/4" CAPSCREW
3	659-364W	1	DUAL LEVER CONTROL	20	D-3730	2	FLANGED BUSHING 5/8" BORE
4	F-2151	1	NUT, 3/8-16 NYLOC, FLANGED	21	F-2058	3	5/16-18 x 3 1/2" CAPSCREW
5	F-2129	2	FHCS, 5/16-18x1-1/2" w/PATCH	22	E-6474	1	SWITCH, SNAP MOUNT
6	625-116P	2	BUSHING, .375 ROD END, SHORT	23	647-242P	1	MOUNTING BRACKET (RH)
7	659-252P	3	TUBE SPACER	24	647-243P	1	MOUNTING BRACKET (LH)
8	659-365P	1	LOWER SHIFT BLOCK	25	625-125P	1	SPACER, CAM DETENT
9	F-2063	6	5/16-18 NYLOC NUT	26	F-2097	1	1/4" FENDER WASHER
10	F-2060	2	1/2-13 NUT, FLANGE LOCK	27	663-051P	1	DAMPER STUD, FEMALE
11	606-151P	2	WASHER, NYLON 1/2 ID x 1/8"	28	638-029P	1	DAMPER BOLT, 1/4-20
12	F-1293	1	HHCS, 1/2-13 x 2" GR5	29	F-1005-01	1	1/4-20, LOCK NUT
13	F-2119	1	FHCS, 1/4-20x3/4", YZ, GR5	30	638-028P	1	DAMPER BOLT, 5/16-18 X 3/4"
14	659-243P	1	SHIFTING YOKE	31	H-2843	1	DUAL ACTION DAMPER
15	F-2182	1	FHCS, 1/4-20x1-1/4", YZ, GR5	32	F-2147	2	FHCS, 3/8-16x1-1/2", YZ, GR5
16	F-1486	2	3/8-16 JAM NUT	33	709-116W	1	BRAKE ROD, WLDT
17	709-083P	1	BRACKET-ANCHOR, DAMPER				

PARKING BRAKE & RELATED PARTS

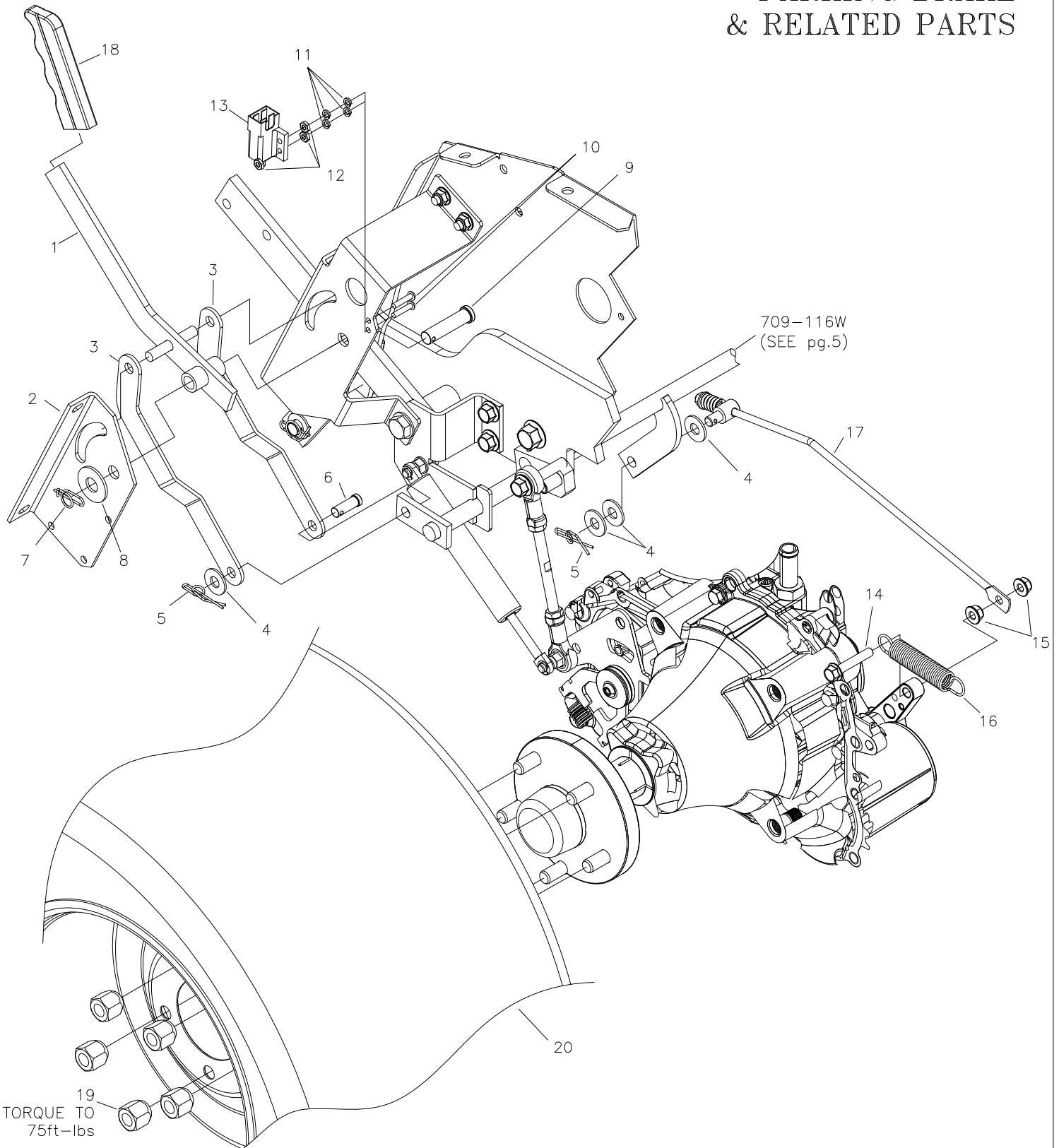

ITEM	PART #	QTY.	DESCRIPTION	ITEM	PART #	QTY.	DESCRIPTION
1	709-180W	1	BRAKE HANDLE WLDT	11	F-1112	4	LOCKWASHER, #10 SPRING
2	709-183P	1	BRAKE LEVER MOUNTING ANGLE	12	F-1448	3	10-32 NYLOC, NUT
3	709-114P	2	LINK, BRAKE	13	E-6297	1	BRAKE SWITCH
4	F-1009-02	4	5/16" FLAT WASHER	14	F-2123	2	FHCS, 5/16-18x1-3/4", YZ, GR5
5	F-1492	1	5/16-3/8 RUE RING	15	F-2063	4	NUT, 5/16-18 NYLOC, FLANGED
6	F-1691	1	3/8" x 1" CLEVIS PIN	16	H-1635	2	SPRING, EXT, 3/4"ODx4"OAL
7	H-2239	1	1/2" RUE RING	17	709-135P	2	BRAKE LINK ROD ASEMBLY
8	F-1521	1	1/2" WASHER, CUSTOM	18	H-1926	1	GRIP
9	F-1897	1	1/2" x 2-1/4" CLEVIS PIN	19	F-1499	5	1/2-20 LUG NUT
10	F-1022-28	2	10-32 x 7/8" MACHINE SCREW	20	D-3894	1	TIRE, 26x14.00-12

TRANSMISSION & RELATED PARTS

(RIGHT HAND SHOWN, LEFT HAND OPPOSITE)

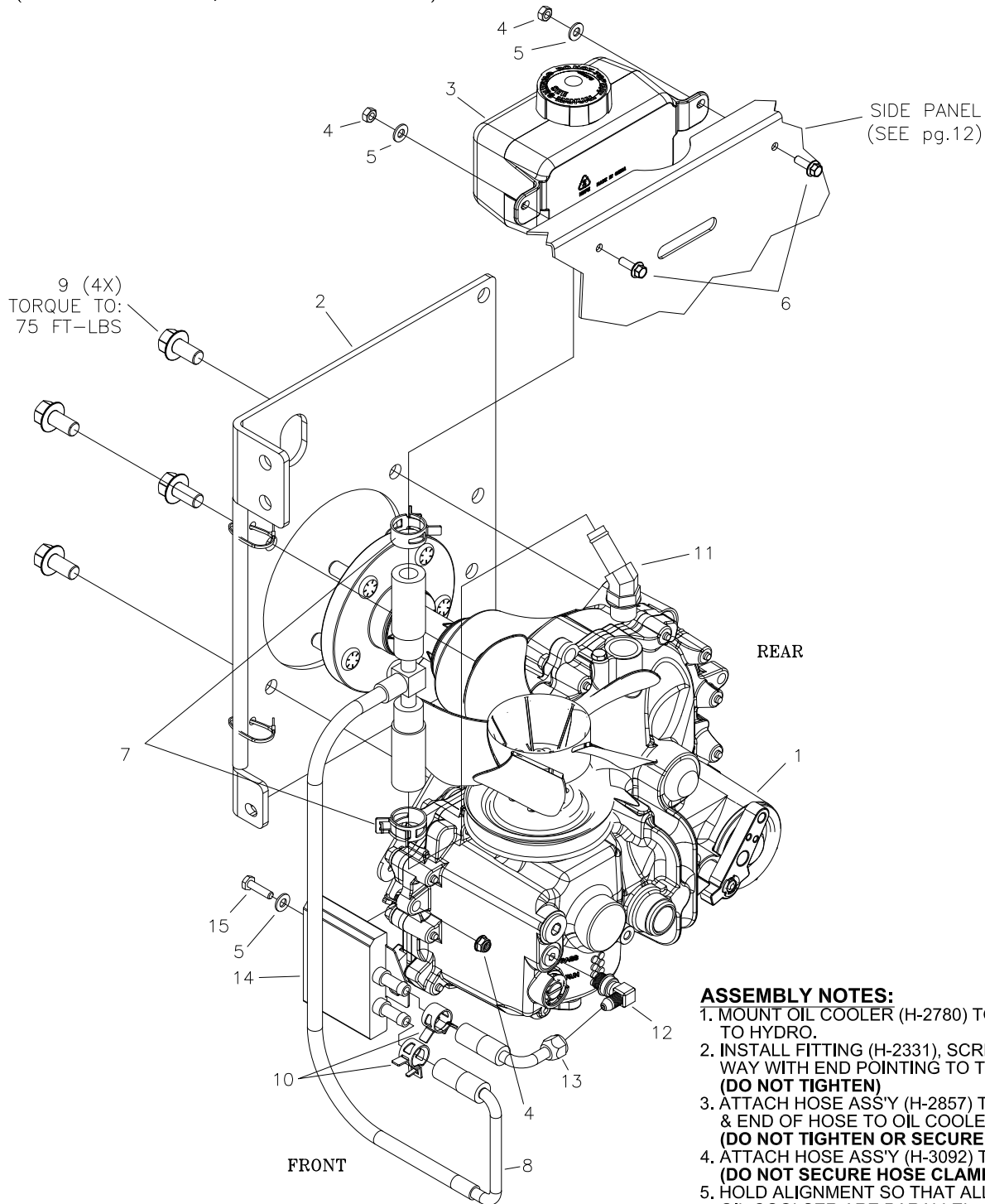

ASSEMBLY NOTES:

1. MOUNT OIL COOLER (H-2780) TO BE PARALLEL TO HYDRO.
2. INSTALL FITTING (H-2331), SCREW IN ALL THE WAY WITH END POINTING TO THE FRONT. **(DO NOT TIGHTEN)**
3. ATTACH HOSE ASS'Y (H-2857) TO FITTING (H-2331) & END OF HOSE TO OIL COOLER (H-2780) **(DO NOT TIGHTEN OR SECURE HOSE CLAMP)**
4. ATTACH HOSE ASS'Y (H-3092) TO OIL COOLER (H-2780) **(DO NOT SECURE HOSE CLAMP)**.
5. HOLD ALIGNMENT SO THAT ALL CONNECTIONS OFF OF OIL COOLER ARE PARALLEL, SECURE FITTING NUTS & THEN SECURE HOSE CLAMPS.

ITEM	PART #	QTY.	DESCRIPTION	ITEM	PART #	QTY.	DESCRIPTION
1	D-3875-01	1	TRANSMISSION, ZT5400, LH	8	H-3092	1	HOSE ASS'Y, LOW PRESSURE, TEE
-	D-3875-02	1	TRANSMISSION, ZT5400, RH	9	F-2143	8	FHCS, 1/2-13x1", YZ, GR5
2	709-095W	1	HYDRO MOUNT WLDT, LH	10	H-3088	2	HOSE CLAMP, 3/4"
-	709-096W	1	HYDRO MOUNT WLDT, RH	11	H-2779	2	FITTING, 45 DEG., HOSE BARB
3	H-2735	2	TANK, HYDRO EXP., HYDROGEAR	12	H-2331	2	9/16", 90 DEG. EL
4	F-2132	6	NUT, 1/4-20 NYLOC, FLANGED	13	H-2857	2	HOSE ASS'Y, LOW PRESSURE, 3/8"
5	F-1009-01	6	1/4" FLAT WASHER	14	H-2780	2	COOLER, OIL, STACKED PLT, 3"x4"
6	F-2162	4	FHCS, 1/4-20 x 3/4", YZ, GR5	15	F-1015-05	2	1/4-20 x 1", CAPSCREW
7	H-3090	2	HOSE CLAMP, 1"				

HYDRO IDLER & RELATED PARTS

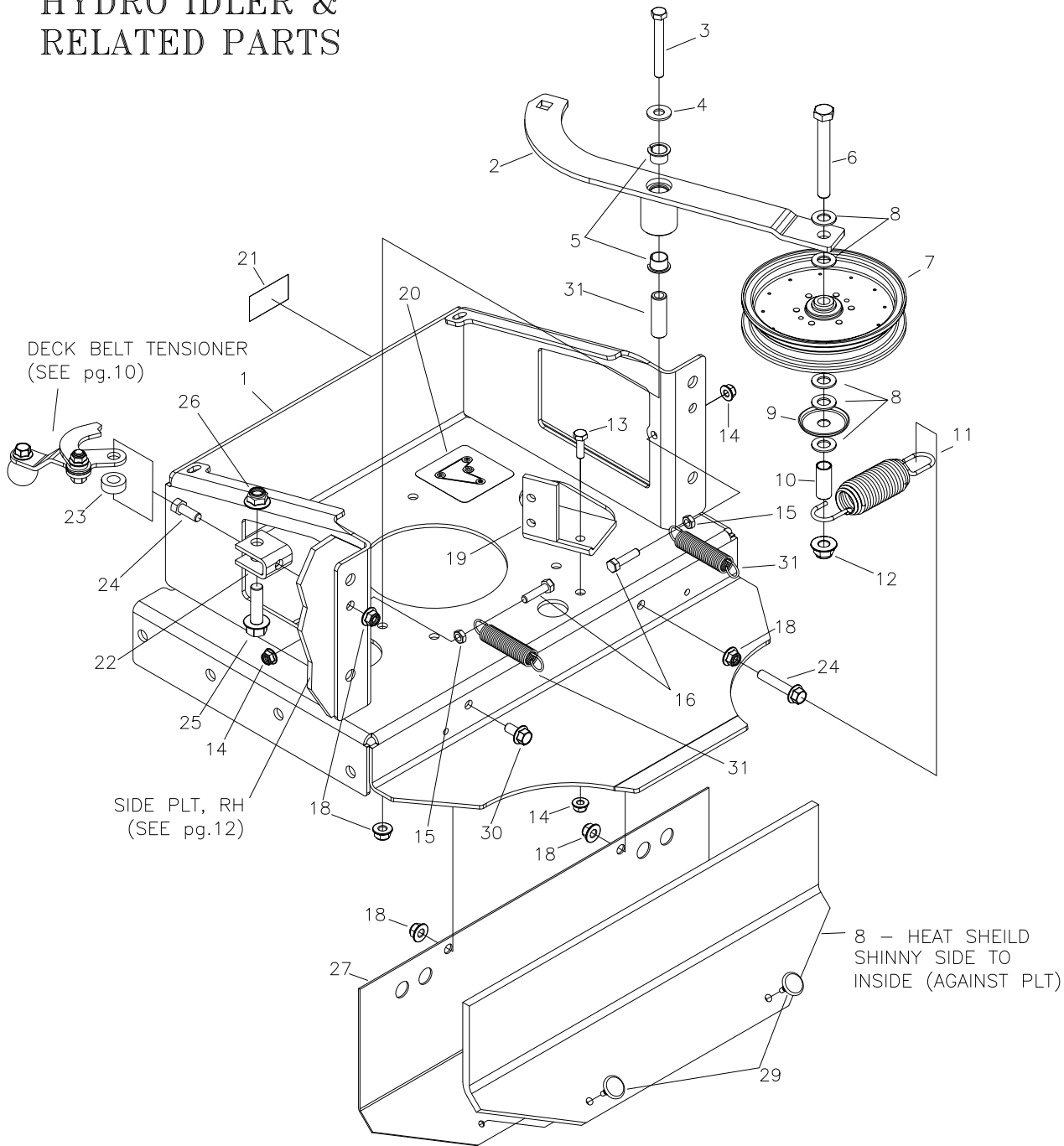

ITEM	PART #	QTY.	DESCRIPTION	ITEM	PART #	QTY.	DESCRIPTION
1	709-009W	1	MOTER MOUNT WLDT	17	F-2124	1	FHCS, 3/8-16 x 3/4", YZ, GR5
2	709-048A	1	IDLER ARM ASSEMBLY	18	F-2151	5	NUT, 3/8-16 NYLOC, FLANGED
3	F-2207	1	HHCS, 3/8-16 X 3", YZ, GR8	19	709-106P	1	CLUTCH STOP
4	F-1009-03	1	3/8" FLAT WASHER	20	P-12918	1	DECAL, HYDRO BELT ROUTING
5	D-3730	2	BUSHING, FLANGED (PART OF 709-048A)	21	P-10777	1	PATENT NUMBER DECAL
6	F-1779	1	HHCS, 1/2-13 X 4", YZ, GR5	22	661-015P	1	SHACKLE
7	D-3903	1	PULLEY, FLAT IDLER, 6"	23	660-038P	1	3/8" SPACER
8	F-1521	3	1/2" WASHER, CUSTOM	24	F-1307	2	3/8-16 x 1-1/4", CAPSCREW
9	620-201P	1	WASHER, BEARING CAP	25	F-2154	1	FHCS, 1/2-13x1-3/4", YZ, GR5
10	629-826P	1	SPACER	26	F-2152	1	NUT, 1/2-13 NYLOC, FLANGED
11	H-2995	1	SPRING, 6.25 X 1.50.D. X 0.154φ	27	709-154P	1	PLATE, FILLER, REAR
12	F-2152	1	NUT, 1/2-13, NYLOC FLANGED	28	709-159P	1	HEAT SHIELD
13	F-1015-15	1	5/16-18 x 1" CAPSCREW	29	F-2165	2	FASTENER, PUSH IN FIR TREE .25x1x1
14	F-2063	3	NUT, 5/16-18 NYLOC, FLANGED	30	H-1635	2	SPRING (SEE pg.24)
15	F-1125	2	5/16-18 NUT	31	709-077P	1	MOUNTING PIN
16	F-1015-17	2	5/16-18 x 1-1/2", CAPSCREW				

ENGINE & RELATED PARTS

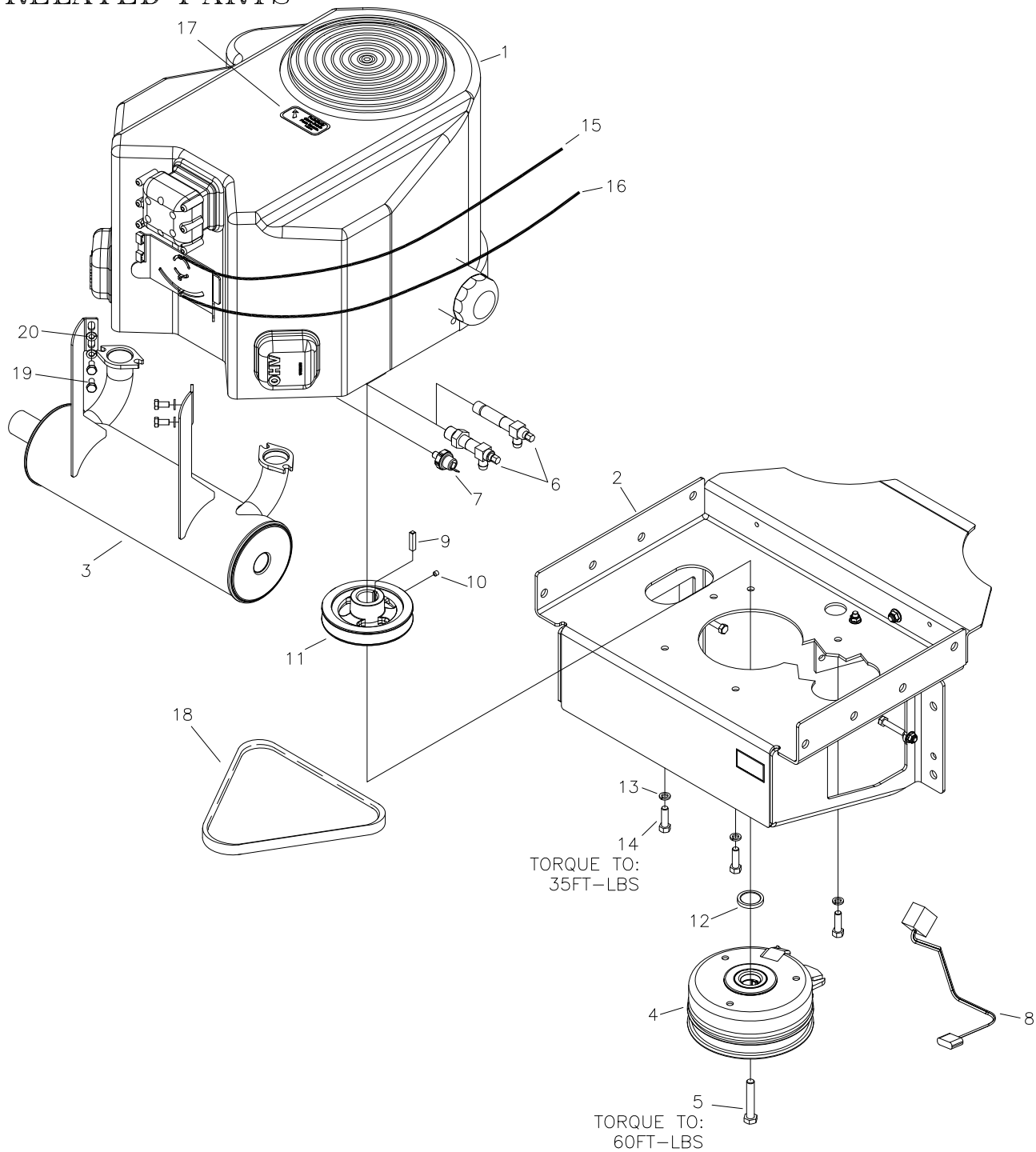

ITEM	PART #	QTY.	DESCRIPTION	ITEM	PART #	QTY.	DESCRIPTION
1	M-5360	1	ENGINE, 35HP KAWASAKI	10	F-1228	1	1/4-20x1/4" SET SCREW NYLOC
-	M-5400	1	ENGINE, 27HP KOHLER	11	709-134P	1	PULLEY, MOTOR, 5.245 DIA
2	709-009W	1	MOTOR MOUNT WLDT	12	709-161P	1	SPACER, ENGINE PULLEY (KOHLER)
3	H-3069	1	MUFFLER, 35HP KAWASAKI	13	F-1019-03	4	3/8" LOCKWASHER
-	H-2774	1	MUFFLER, 27HP KOHLER	14	F-2125	4	HCS, 3/8-16 x 1-1/4" (KAWASAKI)
4	E-6444	1	CLUTCH, 200ft/lb (KOHLER)	-	F-2238	4	HCS, 3/8-16x1-1/4" THD FORM (KOH)
-	E-6425	1	CLUTCH, 250ft/lb (KAWASAKI)	15	H-2611	1	THROTTLE CABLE
5	F-2113	1	CAPSCREW, 7/16-20x2-1/2", GR8	16	H-2404	1	CHOKE CABLE
6	H-2589	1	OIL DRAIN (KOHLER)	17	P-10077-11	1	DECAL "CLEAN DEBRIS"
-	H-2590	1	OIL DRAIN (KAWASAKI)	18	D-3900	1	HYDRO DRIVE BELT, B-71
7	E-6307	1	OIL PRESSURE SWITCH (KAWASAKI)	19	F-1834	4	HHCS, M8-1.25 X 16 (KAWASAKI)
8	E-6575	1	WIRE HARNES, CLUTCH EXTENSION	20	F-1019-02	4	5/16" LOCK WASHER
9	621-113P	1	1/4"SQ x 1-1/4" KEY				

WIRE HARNESS & RELATED PARTS (JOYSTICK)

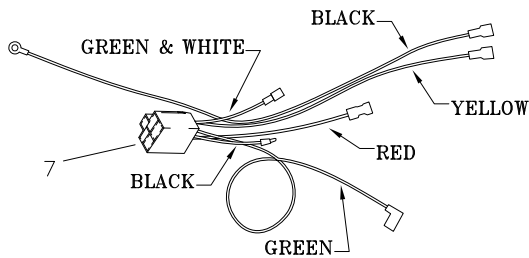
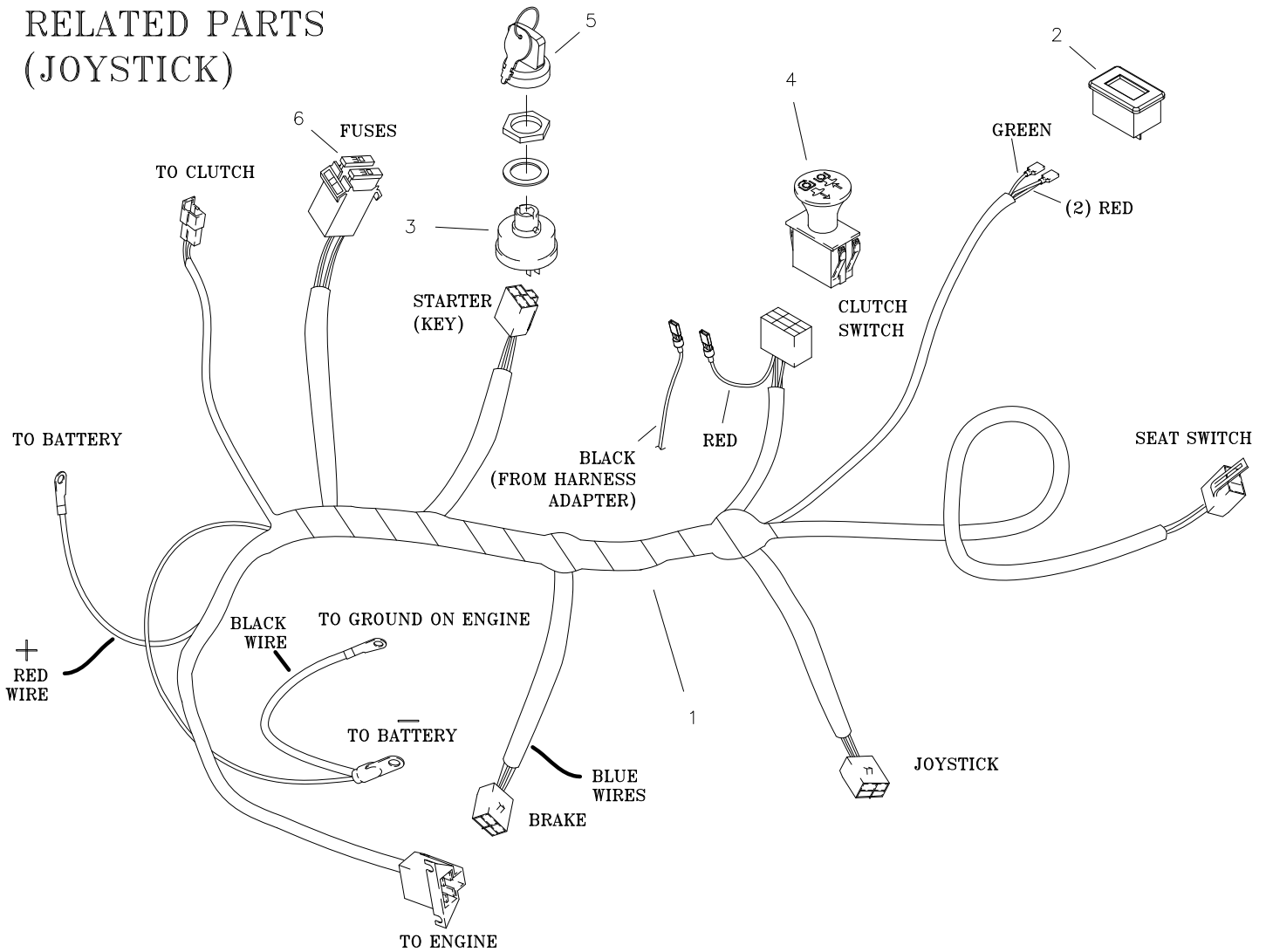

HARNESS ADAPTER

{ONLY REQ'D ON KAWASAKI ENGINES}

ITEM	PART #	QTY.	DESCRIPTION	ITEM	PART #	QTY.	DESCRIPTION
1	E-6548	1	WIRE HARNESS, JS	5	E-6445	1	KEY, SET
2	E-5878	1	HOUR METER	6	E-6207	2	FUSE, #ATC-30
3	E-5873	1	KEY SWITCH (INCLUDES #5)	7	E-6417	1	KAWASAKI HARNESS ADAPTER
4	E-6403	1	PTO SWITCH				

WIRE HARNESS & RELATED PARTS (TWINSTICK)

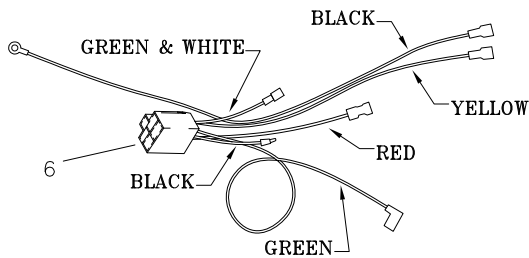
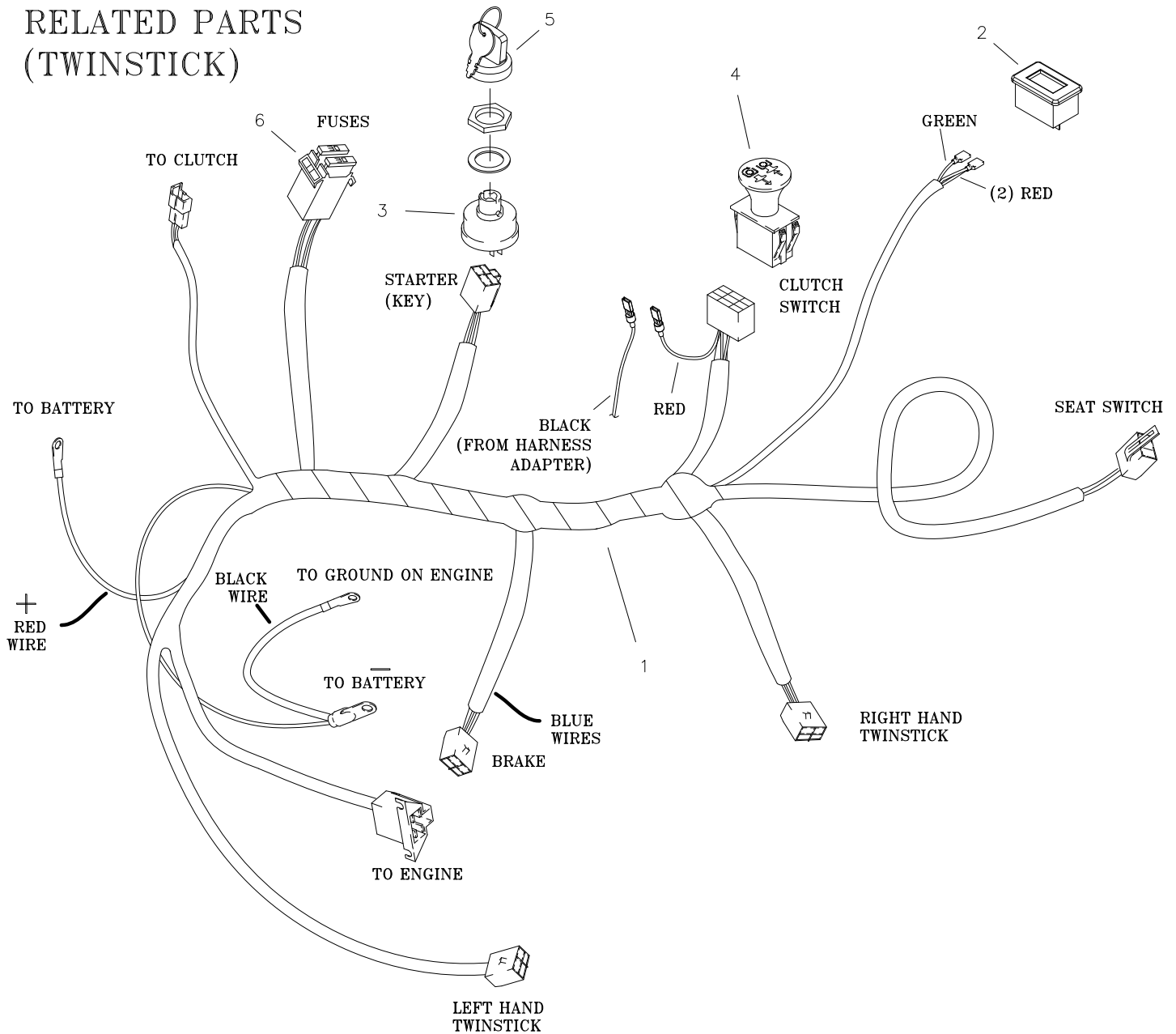

HARNESS ADAPTER
 {ONLY REQ'D ON KAWASAKI ENGINES}

ITEM	PART #	QTY.	DESCRIPTION	ITEM	PART #	QTY.	DESCRIPTION
1	E-6549	1	WIRE HARNESS, TS	5	E-6445	1	KEY, SET
2	E-5878	1	HOUR METER	6	E-6207	2	FUSE, #ATC-30
3	E-5873	1	KEY SWITCH (INCLUDES #5)	7	E-6417	1	KAWASAKI HARNESS ADAPTER
4	E-6403	1	PTO SWITCH				

JACK ASSEMBLY 629-829A

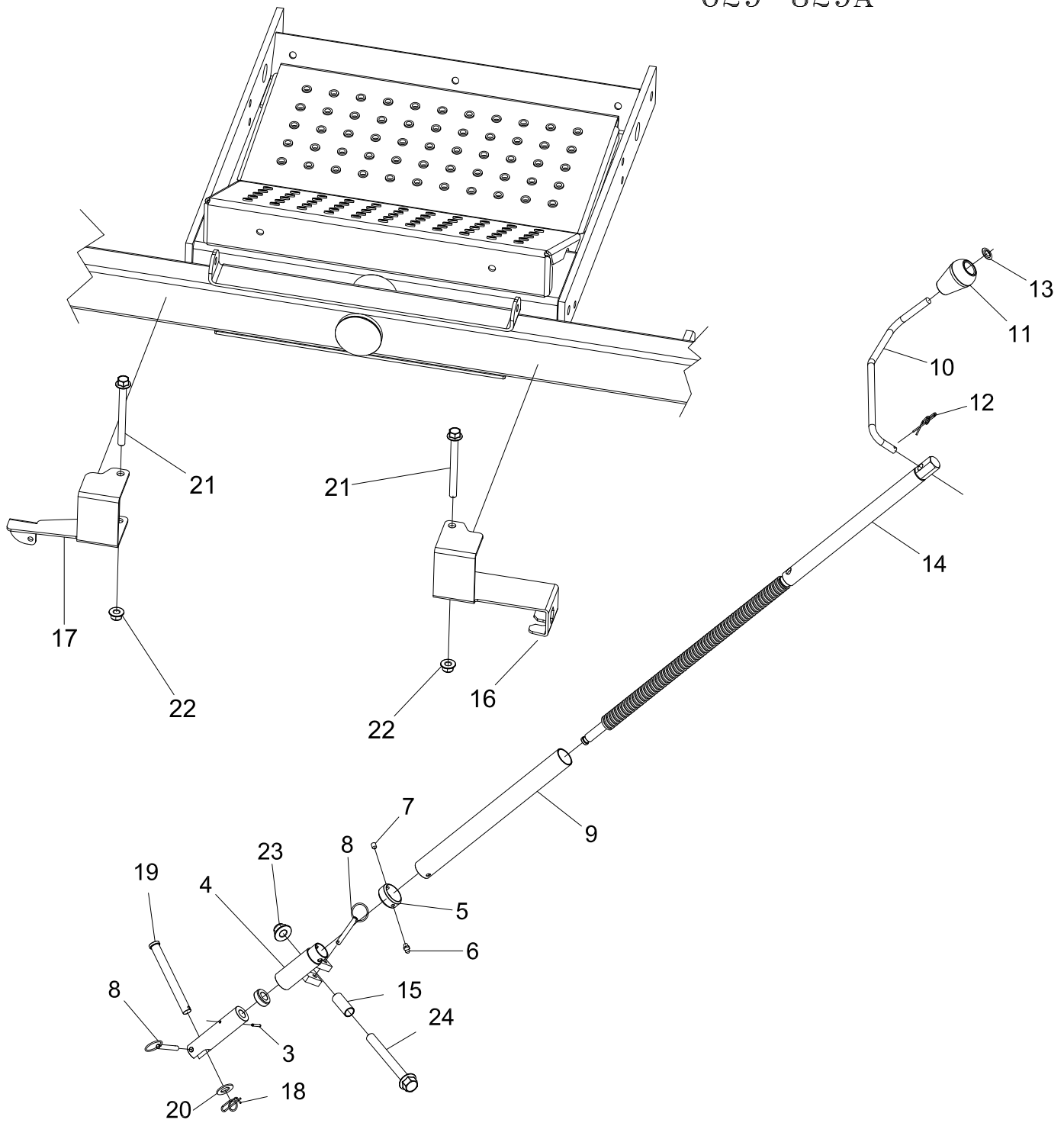

ITEM	PART #	QTY.	DESCRIPTION	ITEM	PART #	QTY.	DESCRIPTION
1	629-825P	1	LOWER JACK CONNECTOR	13	F-1913	1	PUSH RETAINER 3/8 INCH
2	D-3857	1	THRUST BEARING	14	629-836W	1	SHAFT, JACK DRIVE WELDMENT
3	F-1458	1	ROLL PIN, 1/8 X 3/4	15	629-826P	1	SPACER, JACK
4	629-822W	1	DECK FLIP COLLAR WELDMENT	16	629-827P	1	JACK MOUNT BRACKET, LH
5	629-817P	1	JACK TUBE LOCKING COLLAR	17	629-873P	1	JACK MOUNT BRACKET, RH
6	H-1056	1	1/4" Grease Fitting	18	H-2239	1	1/2" Rue Ring
7	F-1467	1	Setscrew, 1/4-20 X 5/16 Nyloc	19	H-2240	1	1/2" x 4-1/2" Clevis Pin
8	F-2183	2	1/4 x 1-1/2" QUICK PIN	20	F-1521	1	1/2" WASHER, CUSTOM
9	629-823P	1	TUBE, GREASE COVER	21	F-2142	2	FHCS, 3/8-16 x 4", YZ, GR5
10	629-216P	1	CRANK HANDLE	22	F-2151	2	Nut, 3/8-16 Nyloc, Flanged
11	H-2343	1	KNOB	23	F-2152	1	Nut, 1/2-13 Nyloc, Flanged
12	F-1492	1	5/16-3/8 Rue Ring	24	F-2181	1	FHCS, 1/2-13 X 4.50, YZ, GR8

Repair Parts Manual

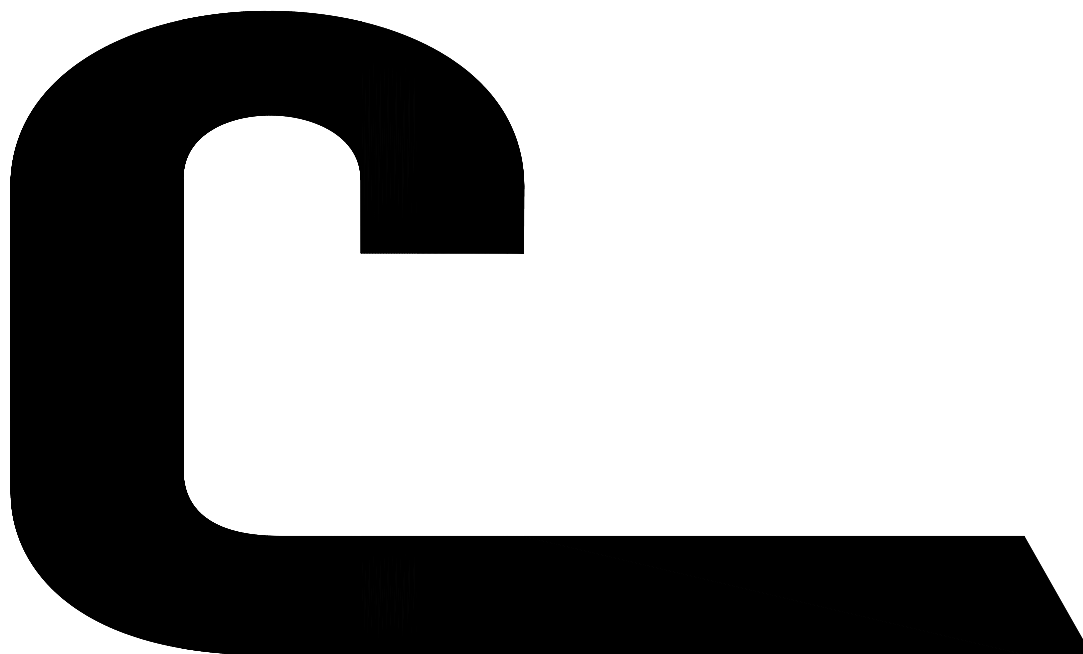

BOSS^{XL}

1525

Country Clipper Division
Shivvers Manufacturing Inc.
613 W. English St.
Corydon, IA 50060-0467
Ph. 641-872-2544
Fax. 641-872-1593