

Safety Instructions & Operators Manual

COUNTRY
CLIPPER®
ZERO TURN MOWER

CHARGER™

1050/1055

Congratulations for buying a **Country Clipper** product. Your **Country Clipper** Zero Turn Radius Riding Mower was designed and built to provide long and trouble free service. Keep in mind that it, like any other mechanical device, can be potentially dangerous if used improperly, and hazard control and accident prevention are dependent upon the awareness, concern, prudence, and proper training of personnel involved in the operation, transport, maintenance, and storage of the equipment. Study this manual and pay special attention to the important Safety Precautions on pages 3-5. Following these instructions will help you continue to enjoy the trouble-free performance expected of the **Country Clipper** product.

TABLE OF CONTENTS

MODEL NUMBER'S & SERIAL NUMBER'S	2
SAFETY	3
ACCIDENT PATTERNS TO AVOID.....	3
SAFETY INSTRUCTIONS AND RECOMMENDATIONS.....	3
SAFETY INTERLOCK SYSTEM.....	5
START UP AND OPERATION	6
CHECKLIST BEFORE OPERATION.....	6
CONTROL LOCATIONS JOYSTICK MODELS.....	6
OPERATION JOYSTICK MODELS.....	7
CONTROL LOCATIONS TWINSTICK MODELS.....	8
OPERATION TWINSTICK MODELS.....	8
OPERATION FREE WHEEL.....	9
MOWING RECOMMENDATIONS.....	10
MAINTENANCE	11
MAINTENANCE SCHEDULE.....	11
MAINTENANCE INSTRUCTIONS.....	12
JOYSTICK ADJUSTMENT.....	13
TWINSTICK ADJUSTMENT.....	15
HYDROSTATIC TRANSMISSION.....	16
SEAT HOLD DOWN LATCH.....	16
PROCEDURE FOR RAISING AND LOWERING THE DECK FOR SERVICING.....	17
SECURING THE DECK PROP.....	19
LEVELING THE DECK.....	20
ADJUSTING THE LATCH PLATE.....	21
TROUBLE SHOOTING CHECK LIST	22
BELT ROUTINGS	24
WIRING SCHEMATIC FOR KAWASAKI JOYSTICK (E-6415)	25
WIRING SCHEMATIC FOR KAWASAKI TWINSTICK (E-6416)	26
WIRING SCHEMATIC FOR KOHLER JOYSTICK (E-6415)	27
WIRING SCHEMATIC FOR KOHLER TWINSTICK (E-6416)	28
HYDRAULIC SCHEMATIC:	29
NOTES / SERVICE RECORDS:	30
NOTES / SERVICE RECORDS:	31

MODEL NUMBER'S & SERIAL NUMBER'S

Date of Purchase: _____

Mower Model Number: _____

Mower Serial Number: _____

Engine Spec Number: _____

Hydro Serial Number (RH): _____

Hydro Serial Number (LH): _____

SAFETY

ACCIDENT PATTERNS TO AVOID

- I. **CONTACT WITH THE ROTATING BLADE** -- This accident usually happens when the operator is clearing the discharge chute of grass, (especially when the grass is wet), or when the operator adjusts the machine without turning it off and waiting for the blades to completely stop.
- II. **PROPELLED OBJECTS** -- Sticks, rocks, wires, and other objects can be propelled out through the discharge chute or from under the mower housing. Bystanders are particularly vulnerable.
- III. **GRASS CATCHER OR GUARD** -- The mower shall not be operated without either the entire grass catcher or guard in place.
- IV. **OVERTURNING** -- This happens when riding mowers are used on steep slopes, embankments or hills. The operator in these cases can come in contact with the blades or sustain injuries during a fall.
- V. **MOWER RUNNING OVER THE VICTIM** -- This usually happens when a riding mower is driven in reverse. The accident victims are most often young children whom, unseen by the operator of the mower, were in the area being mowed.

AT **COUNTRY CLIPPER**, WE SHARE YOUR DESIRE TO PROTECT YOURSELF, YOUR FAMILY, YOUR FRIENDS AND YOUR NEIGHBORS FROM ACCIDENTAL INJURY. OBSERVING AND ENFORCING THE FOLLOWING GUIDELINES WILL HELP TO ENSURE THE SAFETY OF EVERYONE.

PLEASE BE CAREFUL!

SAFETY INSTRUCTIONS AND RECOMMENDATIONS

1. **PEOPLE WHO OPERATE, SERVICE, OR ARE OTHERWISE ASSOCIATED** with the **Country Clipper** Zero Turn Radius Mower should be trained in its proper use and warned of its dangers. Before operating, adjusting, or servicing the **Country Clipper** Zero Turn Radius Mower they should read and understand this entire manual and the engine owner's manual.
2. **AVOID CONTACT WITH MOVING PARTS.** Keep hands and feet from under mower deck and away from blades at all times. Turn engine (motor) off if you must unclog the chute.
3. **AVOID HILLS AND SLOPES.** Use extreme caution when mowing up or down slopes. NEVER mow across the face of a slope. If a slope must be ascended, back up the slope; drive forward when descending. Reduce speed and use caution to start, stop and maneuver. To prevent loss of control on a slope avoid sharp turns, sudden changes in direction, and sudden stops and starts.
4. **DISENGAGE POWER TO MOWER BEFORE BACKING UP.** Do not mow in reverse unless ABSOLUTELY necessary and then only after turning around and observing the entire area behind the mower. Go slowly. Most "running over victim" accidents occur in reverse.
5. **BEGINNING OPERATORS SHOULD LEARN HOW TO STEER** the **Country Clipper** Zero Turn Radius Mower before attempting to mow. Start with slow engine speed and drive without the blades engaged in an open area until comfortable with the machine.
6. **KNOW HOW TO STOP QUICKLY.** Know the location and operation of every control, especially how to brake and how to disengage the mower blades.
7. **DO NOT MOVE CONTROL LEVER(S)** from forward position to reverse position rapidly. The speed and/or direction of travel is affected instantly by movement of the Control Lever(s).

8. **DO NOT ALLOW CHILDREN TO OPERATE MOWER.** Do not allow others who have not had instruction to operate mower.
9. **ALWAYS TURN ENGINE OFF AND REMOVE KEY** before leaving the mower to prevent children and inexperienced operators from starting the engine. Never leave the mower unattended with engine running. Always wait for all moving parts and all sounds to stop before leaving operator's seat.
10. **WEAR STURDY, ROUGH-SOLED WORK SHOES AND CLOSE-FITTING SLACKS AND SHIRTS.** Never operate mower in bare feet, sandals or sneakers.
11. **KNOW THE AREA YOU ARE TO MOW.** Watch for hidden danger such as rocks, roots, sticks, holes, bumps, and drop-offs, etc. Before mowing, pick up all debris in area to be mowed. Sharp and hard objects can be propelled at a high speed and can act like shrapnel. Walk through tall grass **BEFORE MOWING** to make sure there are no hidden dangers. Mow higher than desired in tall grass to expose any hidden objects and/or obstacles, clean the area, and then mow to the desired height.
12. **NEVER REFUEL A MOWER INDOORS.** Allow the engine time to cool before refueling. Unseen vapors may be ignited by a spark. Always clean up spilled gasoline. Never run the engine indoors in a garage or any other closed building. Allow engine to cool before storing in any enclosure. The engine exhaust and gasoline fumes are dangerous.
13. **DISENGAGE BLADES BEFORE DRIVING ACROSS WALKS** or projecting objects.
14. **NEVER REMOVE THE FUEL CAP** or add gasoline to a running or hot engine that has not been allowed to cool for several minutes after running. Always make sure the gas cap is in place.
15. **NEVER CARRY PASSENGERS.**
16. **DO NOT SMOKE AROUND THE MOWER** or the gasoline storage container. Gasoline fumes can easily ignite.
17. **KEEP GASOLINE IN A WELL-VENTILATED AREA** away from your living quarters and in tightly-capped safety cans. Never store mower with gasoline in the tank inside a building where fumes may reach open flame or spark.
18. **DISENGAGE BLADES, STOP ENGINE AND REMOVE IGNITION KEY** before any servicing. Be sure all moving parts and all sounds have stopped. Let engine cool and disconnect the spark plugs so the engine cannot start by accident. A SLIGHT ROTATION OF THE BLADES COULD START THE ENGINE.
19. **KEEP ALL NUTS, BOLTS, AND SCREWS TIGHT** to be sure equipment is in safe working condition, especially blade mounting bolts.
20. **MOWER SHOULD BE STOPPED AND INSPECTED FOR DAMAGE** after striking a foreign object and the damage should be repaired before restarting and operating the equipment. Stop immediately and check for damage or loose parts if mower should start vibrating.
21. **KEEP SAFETY DEVICES AND GUARDS IN PLACE.** If any of the safety switches become inoperable, have them repaired immediately.
22. **FOR PROPER USE OF ROLL OVER PROTECTION SYSTEM (R.O.P.S.)** reference the R.O.P.S. manufactures instruction. (If equipped)
23. **DO NOT STEP OR STAND ON THE MOWER HOUSING.** Step or stand only on the foot deck.
24. **WATCH OUT FOR TRAFFIC** near roadways and when crossing roads.

25. **DO NOT USE MOWER WHEN GRASS IS WET OR SLIPPERY.**
26. **THIS MACHINE IS NOT MEANT FOR HIGHWAY OR STREET USE.** It is not a recreational vehicle and it should not be operated as such.
27. **ALWAYS DISENGAGE THE MOWER BLADE CLUTCH** when transporting.
28. **KEEP ALL SAFETY LABELS IN LEGIBLE CONDITION.** Remove grease, dirt, grass, etc. that may cover safety labels. Replace any safety label that is missing or damaged.
29. **WEAR PERSONAL PROTECTIVE EQUIPMENT.** Eye, ear, feet and head protection is recommended.
30. **ONLY USE COUNTRY CLIPPER APPROVED ACCESSORIES.**
31. **DO NOT CHANGE THE ENGINE GOVERNOR SETTING** or over speed the engine.
32. **BEWARE OF MOWER DISCHARGE DIRECTION** and do not point it at anyone.
33. **DO NOT OPERATE THE MOWER UNDER THE INFLUENCE OF ALCOHOL OR DRUGS.**
34. **USE CARE WHEN LOADING OR UNLOADING MACHINE INTO A TRAILER OR TRUCK.**
35. **USE CARE WHEN APPROACHING BLIND CORNERS,** shrubs, trees, or other objects that may obscure vision.
36. **CLEAN ALL GRASS AND DEBRIS FROM MACHINE TO PREVENT FIRES.** Remove spilled oil or gasoline.
37. **KEEP HANDS AND FEET AWAY FROM MOVING PARTS.** If possible do not make adjustments with the engine running.
38. **NEVER MOW WHEN OTHER PEOPLE OR PETS ARE IN THE AREA.**

39. **CAREFULLY RELEASE PRESSURE FROM COMPONENTS WITH STORED ENERGY.**
40. **USE CARE WHEN REPLACING BLADES.** Wrap the blade(s) or wear gloves, and use caution when servicing them. Only replace blade(s). Never straighten or weld blade(s).
41. **USE JACK STANDS TO SUPPORT COMPONENTS** when required.
42. **KEEP BODY AND HANDS AWAY FROM PIN HOLES OR LEAKS IN HIGH PRESSURE HYDRAULIC LINES.** Always use paper or cardboard to search for leaks, **NEVER** use hands. Make sure all hydraulic connections are tight and that hydraulic lines are in good condition before starting the engine.

SAFETY INTERLOCK SYSTEM

Your *Country Clipper* Zero Turn Radius Mower is equipped with switches interlocked for your safety.

ON JOYSTICK MODELS GROUND DRIVE NEUTRAL IS WHEN THE JOYSTICK (CONTROL LEVER) IS IN THE “**DOWN**” POSITION.

ON TWINSTICK MODELS GROUND DRIVE NEUTRAL IS WHEN BOTH CONTROL LEVERS ARE IN THE “**OUT**” POSITION.

1. The mower blades must be disengaged and the Control Lever(s) must be in the neutral position before the engine will start.
2. The engine will stop if the mower blade clutch is engaged when the operator leaves the driver's seat.
3. The engine will stop if the Control Lever(s) are not in the neutral position when the operator leaves the driver's seat.
4. The engine will stop if the brake is “**SET**” and the Control Lever(s) are not in the neutral position.
5. The engine will stop if the brake is “**SET**” and the mower blade clutch is engaged.

DO NOT OPERATE MOWER IF SAFETY SWITCHES AND GUARDS ARE NOT OPERATING PROPERLY

START UP AND OPERATION

CHECKLIST BEFORE OPERATION

1. Make sure fuel tank is full. Use regular unleaded gasoline (see engine owner's manual for more details).



WARNING



HANDLE GASOLINE WITH CARE -- IT IS HIGHLY FLAMMABLE. DO NOT SMOKE. ENGINE SHOULD BE OFF AND COOL. USE APPROVED GAS CONTAINER. NEVER FILL TANK INDOORS. WIPE UP ANY SPILLS. REPLACE CAP TIGHTLY.

2. Make sure dirt and foreign matter is kept out of gas tank. Use a clean funnel and gas can.
3. Do not mix oil with gasoline.
4. Do not use white, high test or premium gasoline. Do not use de-icers, carburetor cleaners, or other such additives.
5. Check the crankcase oil level. Make sure the engine is off. The mower should be parked on a level area. Do not overfill. (See your engine manual for more detailed instruction.)
6. Check battery fluid level.
7. Inspect V-belts.
8. Check tire pressure:
9. Make sure underside of mower deck is free of grass.
10. Make sure mower blades are sharp and secured tightly.
11. Clean the air intake screen on the engine if necessary.
12. Perform any other maintenance as it becomes necessary. (See the "Maintenance" section of this manual.)
13. If equipped with R.O.P.S. (Roll Over Protection System) reference manufactures instructions.

IMPORTANT: Before cutting grass, clutch must be broken-in as follows: With engine at full RPM engage deck until blades come to full speed and then disengage until blades come to a complete stop. Repeat 10 times to "break-in" the clutch properly.

CONTROL LOCATIONS JOYSTICK MODELS

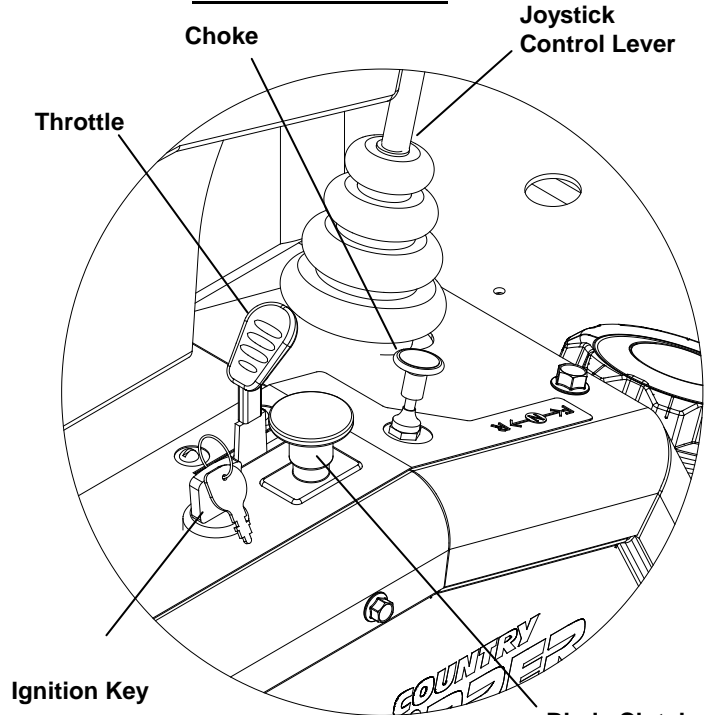

Ignition Key

Joystick Control Lever

Parking Brake Lever

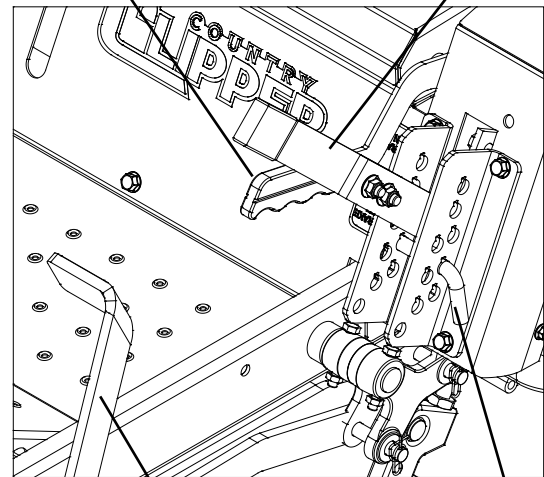

Blade Clutch Switch

Cut Height Adjust.

Cut Height Foot

Cut Height Stop Pin



WARNING



AVOID INHALING EXHAUST FUMES! CARBON MONOXIDE GAS IS COLORLESS, ODORLESS AND CAN CAUSE UNCONSCIOUSNESS AND IS POTENTIALLY LETHAL. DO NOT RUN LAWN MOWER IN GARAGE OR OTHER CONFINED AREAS.

OPERATION **JOYSTICK MODELS**

1. **MOVE JOYSTICK CONTROL LEVER** to neutral “DOWN” position.
2. **SET PARKING BRAKE.** Pull up to set.
3. **DISENGAGE MOWER BLADE CLUTCH** by moving clutch switch to “OFF” position.
4. **PULL ENGINE CHOKE CONTROL** to full position for cold starts (Not applicable on Fuel Injected models).
5. **SET ENGINE THROTTLE TO 1/2 THROTTLE.**
6. **TURN IGNITION KEY to “START”** position and release to “RUN” as soon as engine starts. NOTE: Prolonged cranking will damage starter motor and shorten the battery life
7. **ADJUST ENGINE THROTTLE** for desired engine smoothness and speed. However, use full throttle while mowing.
8. **RELEASE PARKING BRAKE.** Push brake lever down to release.

IMPORTANT:

Until the operator is familiar with the **Country Clipper** Zero Turn Radius Mower, he/she should follow these recommendations: **1)** Disengage the mower blades. **2)** Go very slowly until thoroughly familiar with the machine. **3)** Keep away from fences, buildings, and other obstructions. **4)** Move the Joystick Control Lever smoothly and slowly. **5)** Practice until operation is smooth and efficient.

9. TO DRIVE:

- A. Move the Joystick Control Lever to the “UP” position.
- B. Move the Joystick Control Lever forward to move forward. Increasing forward movement of the Joystick Control Lever will increase the speed of travel.
- C. To reverse the direction, pull the Joystick Control Lever slightly back.
- D. To turn, move the Joystick Control Lever toward the direction you want to turn.

- E. To turn on a zero radius axis, go slowly and move the Joystick Control Lever to the side you wish to turn and slightly to the rear at the same time.



CAUTION



FOR SMOOTH, SAFE OPERATION, MOVE THE JOYSTICK CONTROL LEVER IN A GENTLE, SLOW MOTION. NEVER PULL OR PUSH THE JOYSTICK CONTROL LEVER RAPIDLY, ESPECIALLY ON GRADES.

10. **BRAKING:** To brake mower, gently move the Joystick Control Lever in the direction opposite to travel. Note: If the parking brake is engaged with the Joystick Control Lever in the “UP” position the engine will stop.
11. **CUTTING HEIGHT ADJUSTMENT:** While holding the Cut Height Adjustment Lever with enough hand pressure to freely move the Cut Height Pin, rotate the Cut Height Stop Pin so the key on the pin aligns with the key slot, then pull it out and move the Cut Height Adjustment Lever to the desired cut height. Reinsert the Cut Height Stop Pin.
12. **ENGAGE MOWER BLADE CLUTCH:** Set engine throttle to 1/2–3/4 throttle, engage the Blade Clutch Switch to the “ON” position, set throttle to full. Note: The engine will not start with the blade clutch switch in the “ON” position. Engine will stop if the clutch switch is “ON” and the Operator is not in the seat.



CAUTION



AVOID HILLS AND SLOPES. USE EXTREME CAUTION WHEN MOWING UP OR DOWN SLOPES. NEVER MOW ACROSS THE FACE OF A SLOPE. IF A SLOPE MUST BE ASCENDED, BACK UP THE SLOPE; DRIVE FORWARD WHEN DESCENDING.

13. TO STOP:

- A. Move Joystick Control Lever to neutral position and then to the “DOWN” position.
- B. Disengage the mower blade clutch by moving the clutch to the “OFF” position.
- C. Set the parking brake.
- D. Turn ignition key to “OFF” position.
- E. Remove the key and wait for all movement and sound to cease before dismounting.

CONTROL LOCATIONS TWINSTICK MODELS

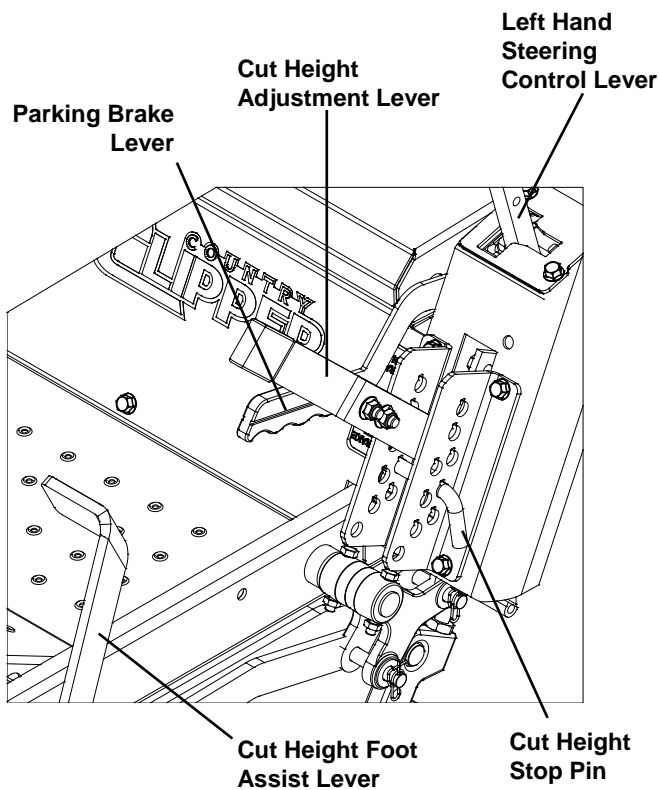
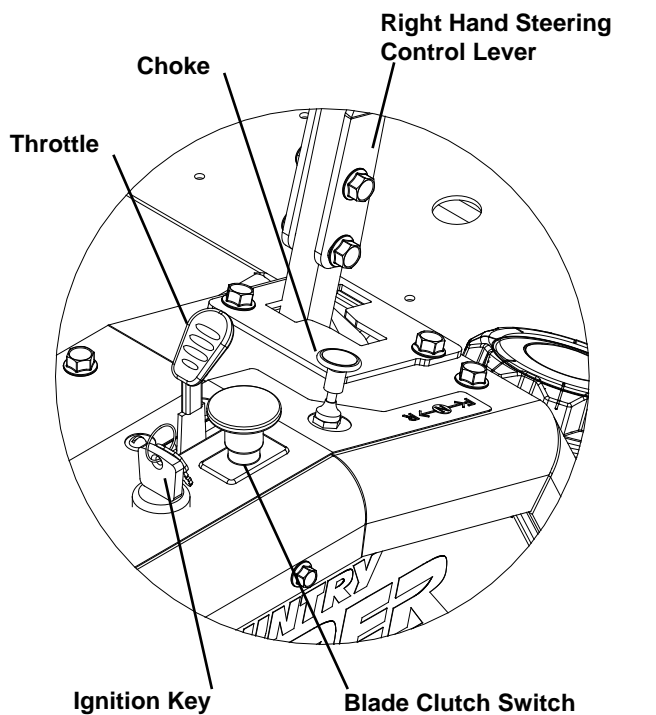

WARNING



AVOID INHALING EXHAUST FUMES -- CARBON MONOXIDE GAS IS COLORLESS AND ODORLESS, AND CAN CAUSE UNCONSCIOUSNESS, AND IS POTENTIALLY LETHAL. DO NOT RUN LAWN MOWER IN GARAGE OR OTHER CONFINED AREA.

OPERATION TWINSTICK MODELS

1. **MOVE STEERING CONTROL LEVERS** to neutral "OUT" position.
2. **SET PARKING BRAKE.** Pull up to set.
3. **DISENGAGE MOWER BLADE CLUTCH** by moving clutch switch to "OFF" position.
4. **PULL ENGINE CHOKE CONTROL** to full position for cold starts.
5. **SET ENGINE THROTTLE TO 1/2 THROTTLE.**
6. **TURN IGNITION KEY** to "START" position and release to "RUN" as soon as engine starts. NOTE: Prolonged cranking will damage starter motor and shorten the battery life.
7. **ADJUST ENGINE THROTTLE** for desired engine smoothness and speed. However, use full throttle while mowing.
8. **RELEASE PARKING BRAKE.** Push brake lever down to release.

IMPORTANT:

Until the operator is familiar with the **Country Clipper** Zero Turn Radius Mower, he/she should follow these recommendations: **1)** Disengage the mower blades. **2)** Go very slowly until thoroughly familiar with the machine. **3)** Keep away from fences, buildings, and other obstructions. **4)** Move the Steering Control Lever smoothly and slowly. **5)** Practice until operation is smooth and efficient.

9. **TO DRIVE:**
 - A. Move the Steering Control Levers to the "IN" position.
 - B. Move the Steering Control Levers forward to move forward. Increasing forward movement of the Steering Control Levers will increase the speed of travel.

- C. To reverse the direction, pull the Steering Control Levers slightly back.
- D. To turn, move one Steering Control Lever slightly ahead of the other.
- E. To turn on a zero radius axis, go slowly and move one Steering Control Lever forward and one Steering Control Lever rearward. (For a right hand turn the left hand Steering Control Lever will be ahead of the right hand Steering Control. For a left hand turn the right hand Steering control will be ahead of the left hand Steering Control.)

! CAUTION !

FOR SMOOTH, SAFE OPERATION, MOVE THE STEERING CONTROL LEVER(S) IN A GENTLE, SLOW MOTION. NEVER PULL OR PUSH THE STEERING CONTROL LEVER(S) RAPIDLY, ESPECIALLY ON GRADES.

- 10. **BRAKING:** To brake mower, gently move the Steering Control Levers in the direction opposite to travel. **NOTE:** If the parking brake is engaged with the Steering Control Lever(s) in the "IN" position the engine will stop.
- 11. **CUTTING HEIGHT ADJUSTMENT:** While holding the Cut Height Adjustment Lever with enough hand pressure to freely move the Cut Height Pin, rotate the Cut Height Stop Pin so the key on the pin aligns with the key slot, then pull it out and move the Cut Height Adjustment Lever to the desired cut height. Reinsert the Cut Height Stop Pin.
- 12. **ENGAGE MOWER BLADE CLUTCH:** Set engine throttle to 1/2-3/4 throttle, engage the Blade Clutch Switch to the "ON" position, set throttle to full. **Note:** The engine will not start with the blade clutch switch in the "ON" position. Engine will stop if the clutch switch is "ON" and the Operator is not in the seat.

! CAUTION !

AVOID HILLS AND SLOPES. USE EXTREME CAUTION WHEN MOWING UP OR DOWN SLOPES. NEVER MOW ACROSS THE FACE OF A SLOPE. IF A SLOPE MUST BE ASCENDED, BACK UP THE SLOPE; DRIVE FORWARD WHEN DESCENDING.

13. TO STOP:

- A. Move Steering Control Levers to neutral position and then to the "OUT" position.
- B. Disengage the mower blade clutch by moving the clutch to the "OFF" position.
- C. Set the parking brake.
- D. Turn ignition key to "OFF" position.
- E. Remove the key and wait for all movement and sounds to cease before dismounting.

! CAUTION !

WHEN LEAVING THE MOWER UNATTENDED, ALWAYS REMOVE THE KEY AND SET THE PARKING BRAKE, EVEN IF JUST FOR A FEW MOMENTS. HELP PROTECT CHILDREN AND OTHER UNAUTHORIZED PERSONS FROM ACCIDENTS.

**OPERATION
FREE WHEEL**

1. TO FREE WHEEL:

- A. **Unlock Transmission:** Unscrew the bypass valve between 1/2 -1 full turn counterclockwise. **NOTE:** Both sides must be done in order to free wheel.
- B. To re-engage the transmissions screw the bypass valve clockwise until tight **(DO NOT OVER TIGHTEN)**. **NOTE:** Both sides must be done in order to lock the wheels.

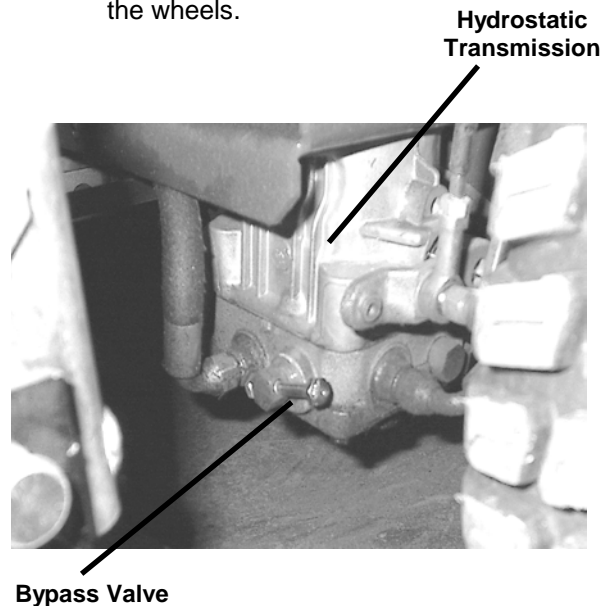

NOTE: The tractor should never be pulled at more than 2 miles per hour or for any appreciable distance.



CAUTION



**NEVER OPERATE MOWER WITHOUT
DISCHARGE CHUTE IN PLACE.**

MOWING RECOMMENDATIONS

1. Keep mower blades sharp.
2. Make sure deck and discharge are clean.



CAUTION



**TURN ENGINE OFF AND WAIT FOR ALL
MOVING PARTS TO STOP BEFORE
CLEANING DISCHARGE CHUTE.**

3. When mowing tall grass, make two passes. Mow off $\frac{1}{2}$ of the desired cut on the first pass, and then the desired height the second pass. Check for hidden dangers.
4. Go slowly for trimming.
5. Always cut grass with the engine at full throttle speed.

NOTE: Operating the engine at full throttle assures that the cutting blades are operating at optimum cutting speed. Control ground speed with the Control Lever(s).

6. Vary ground speed to suit conditions (i.e. go slower in tall thick grass, on hills, wet conditions, etc.).

MAINTENANCE



CAUTION



**BEFORE PERFORMING ANY MAINTENANCE, TURN OFF ENGINE
REMOVE KEY AND DISCONNECT SPARK PLUGS. USE EXTREME CARE WHEN WORKING ON
MACHINERY. DO NOT WEAR WATCHES OR JEWELRY. DO NOT WEAR LOOSE FITTING
CLOTHES, AND OBSERVE ALL COMMON SAFETY PRACTICES WITH TOOLS.**

MAINTENANCE SCHEDULE

Maintenance Service Interval	Maintenance Procedure
Before Each Use or Daily	<input type="checkbox"/> Check Engine Oil Level. <input type="checkbox"/> Check Mower Blades. <input type="checkbox"/> Check Operator Presence Control System. <input type="checkbox"/> Check for Loose Hardware. <input type="checkbox"/> Clean Engine Cooling System. <input type="checkbox"/> Remove Debris From Engine. <input type="checkbox"/> Remove Debris Build-Up Hydrostatic Transmission & Cooler
After Each Use or Daily	<input type="checkbox"/> Clean Grass Build-Up from Deck Cutting Chamber.
After First 5 Hours	<input type="checkbox"/> Change Engine Oil. <input type="checkbox"/> Check Wheel Lug Nuts. (75 ft/lbs or 102 Nm)
After First 75 Hours	<input type="checkbox"/> Change Hydrostatic Transmission Oil & Filter (see pg. 16)
Every 10 Hours	<input type="checkbox"/> Check Tire Pressure. (12-15 Psi / 83-103 kPa) <input type="checkbox"/> Check Battery Fluid <input type="checkbox"/> Sharpen Mower Blades
Every 25 Hours	<input type="checkbox"/> Service Air Cleaner. (Increase Frequency Under Severe Conditions. See Engine Owner's Manual for additional information.) <input type="checkbox"/> Check Wheel Lug Nuts. (75 ft/lbs or 102 Nm)
Every 50 Hours	<input type="checkbox"/> Check Hydraulic Oil Level. <input type="checkbox"/> Check Drive Belt Condition. <input type="checkbox"/> Check Engine RPM (3500-3600 rpm)
Every 100 Hours	<input type="checkbox"/> Change Engine Oil & Filter. (Increase Frequency Under Severe Conditions. See Engine Owner's Manual for Additional Information.) <input type="checkbox"/> Remove Engine Shrouds & Clean Cooling Fins. <input type="checkbox"/> Check Spark Plug
Every 400 Hours	<input type="checkbox"/> Change Hydrostatic Transmission Oil & Filter (see pg. 16)
Every 500 Hours Or Annually	<input type="checkbox"/> Grease Front Caster Pivots <input type="checkbox"/> Replace Air Filter Element <input type="checkbox"/> Check Spark Plugs <input type="checkbox"/> Service Battery

Replace Safety decals when illegible. Write factory for free replacement.

MAINTENANCE INSTRUCTIONS

1. ENGINE:

For complete maintenance and operating information for your engine, please refer to your engine operating and maintenance instructions furnished by the engine manufacturer and included in your **Country Clipper** Zero Turn Radius Mower information packet.

NOTE: Air intake screen must be kept clean. If plugged, engine may be seriously damaged by overheating.

2. BATTERY:

CAUTION

BATTERY ELECTROLYTE IS A POISONOUS AND CORROSIVE SULFURIC ACID SOLUTION. AVOID SPILLING ON SKIN, EYES, AND CLOTHING.

Keep the electrolyte level above the plates in each cell by adding distilled water as it becomes necessary. Add water just before operating the mower to mix the water with the solution. Be careful not to overfill the battery -- the electrolyte solution is corrosive and can cause damage to surrounding metal parts if it should spill. When taking the battery out of the mower for servicing, make sure to connect the cables to the battery exactly as they were prior to removal. Always disconnect the ground (-) wire **first** and always reconnect the ground (-) wire **last**.

Keep the battery clean. Remove the corrosion around the battery terminals by applying a solution of one part baking soda to four parts water. Coat all exposed terminal surfaces with a light layer of grease or petroleum jelly to prevent corrosion.

NOTE: At temperatures below 32 degrees F (0 degrees C) the full charge state must be maintained to prevent cell electrolyte from freezing and causing permanent battery damage.

3. TIRES:

Correct tire pressure is essential for efficient operation of the mower. Check tire pressure as requested in the maintenance schedule. Inflate tires to the pressures listed below:

Model	Front tires	Rear tires
All Models	12-15 psi 83-103 kPa	12-15 psi 83-103 kPa

Lug nuts should be torqued to 75 ft/lbs and checked regularly for tightness.

4. MOWER BLADES:

Check sharpness of mower blades after every 10 hours of operation. To sharpen blades proceed as follows:

CAUTION

STOP ENGINE, REMOVE IGNITION KEY AND SPARK PLUGS FOR SAFETY.

- A. Remove bolt and blade washer mounting blade on shaft. Remove blade.
- B. Blades should be discarded when worn excessively.

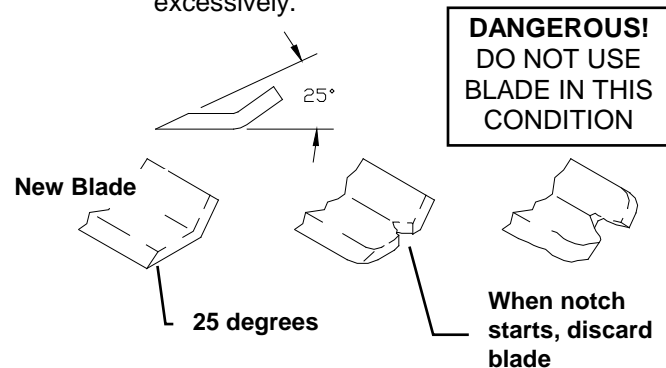

- C. Sharpen blades with a hand file, electric grinder or blade sharpener. Wear gloves and eye protection when sharpening. Grind blade at original 25 degree bevel.
- D. Check balance of blade by positioning the blade on a nail or blade balance pedestal. Grind the blade on the end that is heavier until both sides balance.
- E. Install blade, blade washer and bolt. Make sure to torque bolt to 100 ft-lbs.

5. V-BELTS:

All belts should be checked every 50 hours. Replace any belts found to be in poor condition. All belts are equipped with spring loaded belt tighteners and do not require tightening adjustments.

6. LUBRICATION:

- A. Engine: Follow engine manufacturer's recommendation.
- B. Front Caster Pivots: Lubricate fittings with several pumps of multi-purpose grease from a grease gun. (See pg. 18)

7. PARKING BRAKE ADJUSTMENTS:

- A. Move Parking Brake Lever to the "OFF" position.
- B. Firmly hold the Brake Arm forward and line up the Shoulder bolt with nearest hole in the Brake Adjustment Link and tighten the Shoulder Bolt and Lock Nut. Repeat for other side. The Park Brake Handle should require around 45lbs to pull it on. If the Handle force is too high move the Shoulder bolt(s) to the next lighter setting. If too light, move to next heavier setting.

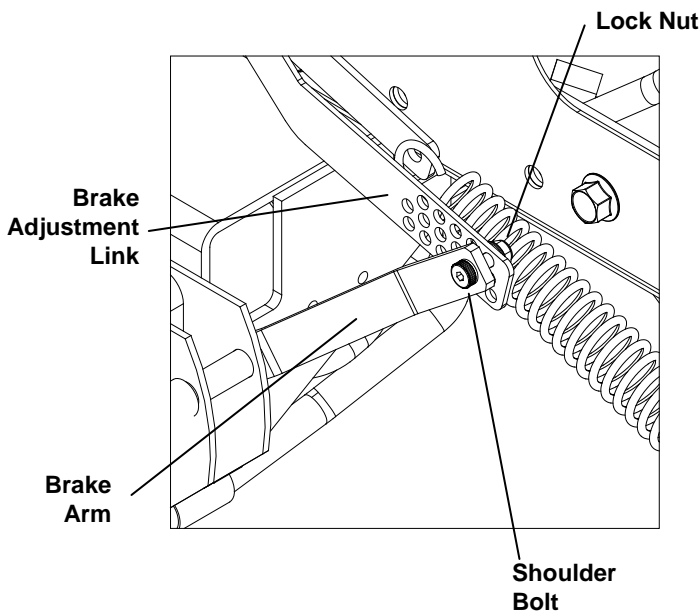

JOYSTICK ADJUSTMENT

1. SETTING TRACKING AND FORWARD SPEED:

- A. The initial setting is done with the engine TURNED OFF.
- B. Remove both fender skirts.
- C. Start by setting the RH transmission speed. Disconnect the linkage that is connected to the left side transmission at the upper end.

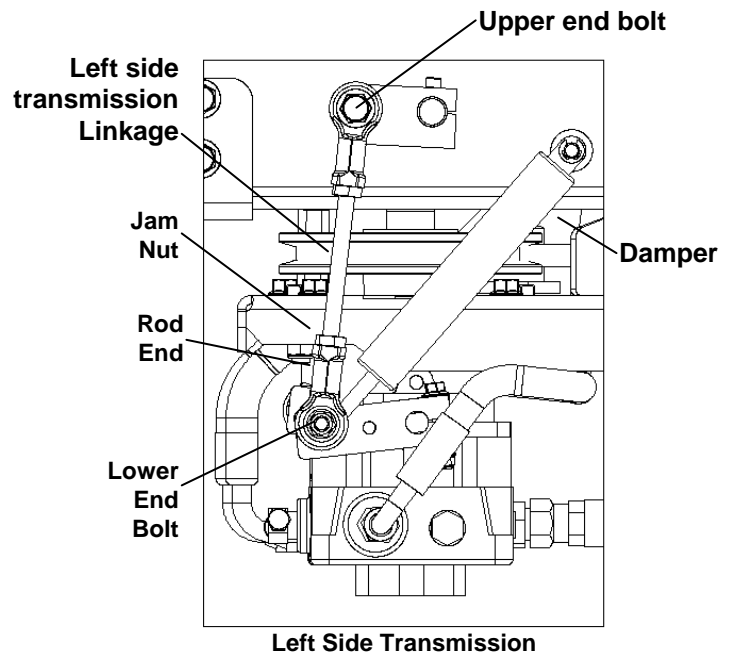

- D. On the outside (long) linkage that goes from the joystick to the right side transmission, Loosen the jam nuts on both ends of the coupling nut. One of these is a left-hand thread. Rotate the coupling nut a couple turns to lengthen it.

IMPORTANT:

Use two wrenches (one on the nut and one on the coupling nut or rod end housing) when loosening or tightening jam nuts to prevent damaging the rod end ball joints!

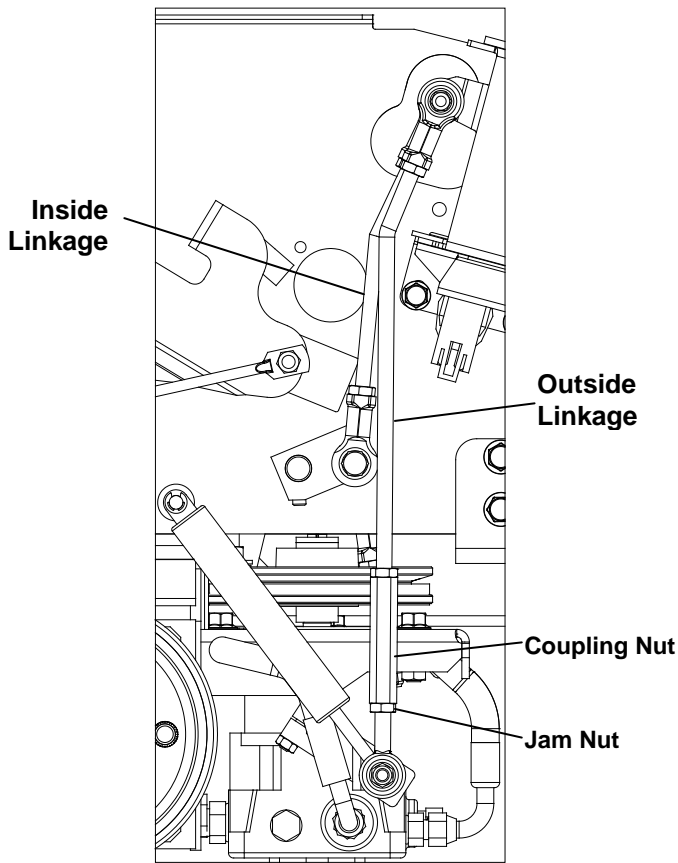

Right Side Transmission

- E. Lift the joystick control handle out of the neutral position and hold it firmly in the full forward position. Now, by hand, rotate the coupling nut shortening the linkage until resistance is felt from the transmission control bottoming out in the transmission. Rotate the coupling nut back and forth a couple times to confirm, and mark this position.
- F. Now rotate the coupling nut exactly **one full turn longer** and retighten the jam nuts. When retightening make sure that the ball joints on both top and bottom are well centered so that they do not bind up when moving the joystick handle to the extremes of its travel.

NOTE: This full turn longer is **required** to prevent internal damage to the transmission.

- G. Now set the LH transmission speed. Reconnect the linkage to the **left** side transmission. (see left side transmission illustration on previous page).

- H. Loosen the jam nuts on both ends of the **left** side transmission linkage. One of these is a left-hand thread. Now rotate the linkage rod a couple turns to lengthen it.
- I. Hold the joystick control handle firmly in the full forward position. Rotate the left side transmission linkage rod to shorten the linkage until resistance is felt from the transmission control bottoming out in the transmission. Rotate the rod back and forth a couple times to be sure, and mark this position.
- J. Now rotate the linkage rod exactly **one full turn longer** and retighten the jam nuts. Make sure that the ball joints on both top and bottom are centered.

NOTE: This full turn longer is **required** to prevent internal damage to the transmission.

- K. Test drive the mower to check for tracking at full speed. If needed, slow the fast side by lengthening the control rod connected to the faster transmission. Use small adjustments of about ¼ turn. Replace the fender skirts when done.

2. SETTING NEUTRAL:

If, with the joystick handle in the DOWN or start position and the engine running the mower moves or travels, it is necessary to adjust neutral. Raise the drive wheels off the ground, secure the mower on blocks or jack stands and proceed as follows:

- A. Remove the fender skirt on the joystick side. Loosen the two nuts on the bottom of the joystick neutral plate just enough so that the plate can move freely.

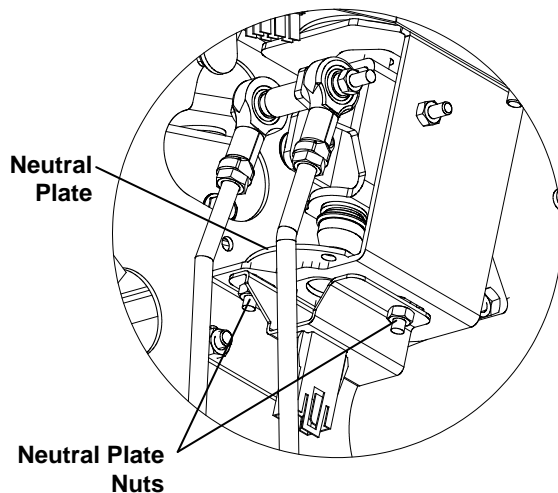

- B. Start the engine. With the joystick still down, position the handle so both wheels are stationary.
- C. Tighten the two nuts on the bottom of the neutral plate, being careful not to shift it out of position.
- D. Recheck neutral before placing the mower back on the ground. Then shut off the engine and remove the mower from the blocks. Replace the fender skirt.

3. JOYSTICK CONTROL LEVER SENSITIVITY ADJUSTMENT:

To change the sideways turning response, adjust as follows:

- A. Remove the right hand fender skirt exposing the Joystick Control Lever assembly.
- B. Remove the cross bolt, nut, & spacers.
- C. For quicker reacting steering place the long, silver colored spacers toward the inside of the rod end ball joints and the shorter, gold colored spacers on the outside of the ball joints. For slower reacting steering place the short, gold colored spacers on the inside and the longer, silver colored spacers on the outside. All 4 spacers must be used when reassembling.

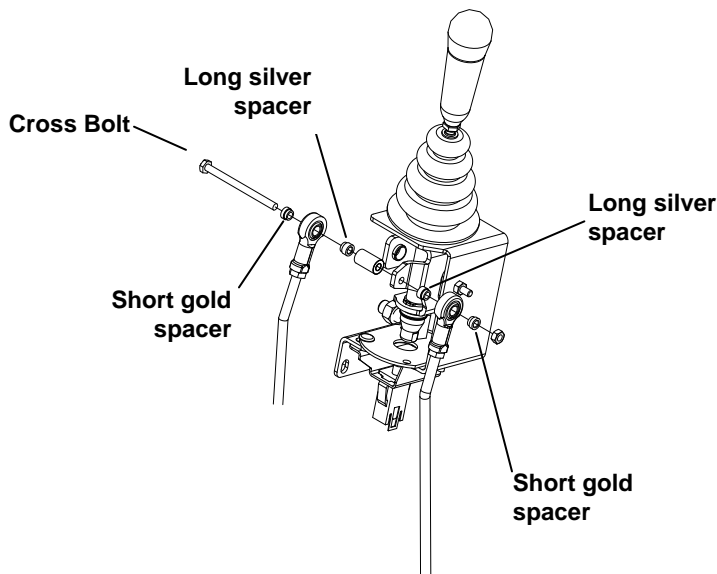

TWINSTICK ADJUSTMENT

1. TWINSTICK CONTROL LEVER NEUTRAL ADJUSTMENT:

- A. Loosen the bolts holding the Neutral Plate.
- B. Pull back the control lever until the wheel spin is zero.
- C. Tilt the Control lever outward, using the lever, position and tighten the bolts holding the Neutral Plates.

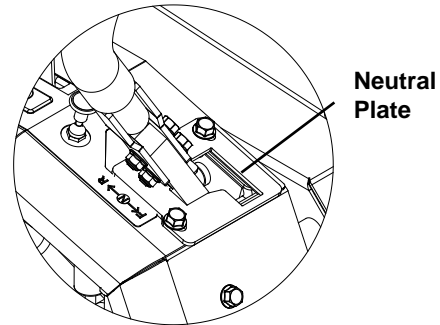

2. TWINSTICK CONTROL LEVER FORWARD TRACKING:

In a large open area, actuate the Twinstick Control levers into the full forward position. If the mower veers in either direction left or right some adjustment is necessary. If the mower veers to the right, then the left transmission needs to be slowed down. If the mower veers to the left then the right transmission needs to be slowed down.

- A. Stop the machine and shut off the engine.
- B. Slightly loosen the nuts around the turnbuckle on the faster side. Lengthen the lower linkage rod by ¼ turn increments, retighten and retest, until the mower tracks straight.
- C. Once the tracking is to the operators liking, completely tighten the nuts on the turnbuckle. Recheck and adjust the Neutral Plate if required.
- D. Reinstall the fender skirts and tighten all bolts.

3. TO ADJUST “IN” OR OPERATING POSITION OF THE TWINSTICK STEERING CONTROL LEVERS:

If the Control levers are too close in the center or the Control Levers Drag on the Neutral Plate, adjust as follows:

- A. Tilt the Control Lever outward, loosen the lock nut and adjust the bolt until the gap between the handles is correct or the Control lever does not rub on the Neutral Plate.
- B. Tighten the lock nut after the adjustment is made.

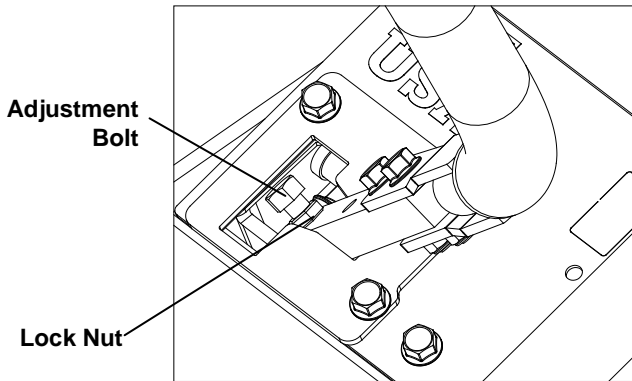

HYDROSTATIC TRANSMISSION

Check oil level in Hydraulic Oil Reservoir after every 25 hours of use. Oil level should be checked when oil is COLD. If necessary add 20W-50 motor oil to the reservoir. **DO NOT OVERFILL.** Thoroughly clean the Hydraulic Oil Reservoir Cap and the surrounding area **PRIOR** to removal of the cap. Take caution to keep all foreign matter out of the Hydraulic Oil Reservoir.

NOTE: NEVER WASH ACROSS VENTED CAP WITH WATER OR STEAM.

It is essential that the unit exterior be free from debris prior to doing any fluid maintenance.

1. HYDROSTATIC TRANSMISSIONS FLUID CHANGE:

SAE 20W-50 engine oil has been selected for use by the factory and is recommended for normal operating temperatures.

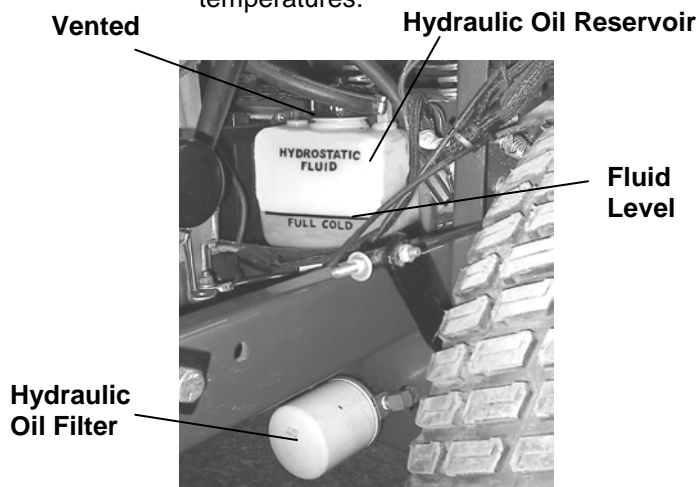

- A. Set the park brake.
- B. Remove the oil filter.
- C. After all the oil is drained out, replace the filter (use part # H-2026 when ordering from Country Clipper). Wipe off the filter base surface, apply a film of new oil to the gasket of the new filter and hand tighten $\frac{3}{4}$ to one full turn after the filter gasket contacts the filter base surface.
- D. Refill the transmission with the recommended oil through the Hydraulic Oil Reservoir. continue filling until the "Full Cold" line is reached on the reservoir.
- E. Recheck oil level after running.

SEAT HOLD DOWN LATCH

To release the seat hold down latch, pull the latch handle to the right.



PROCEDURE FOR RAISING AND LOWERING THE DECK FOR SERVICING

1. RAISING THE DECK TO THE SERVICING POSITION:

- A.** Remove cut height adjustment pin and completely lower the cut height adjustment lever. Re-insert the cut height adjustment pin immediately above Cut Height Adjustment Lever (this will lock the cut height adjustment lever into the lowest position).
- B.** Carefully rotate the Deck Belt Tension Latch to release tension on the Deck Belt. Remove the engine to deck Drive belt from the clutch on the engine. Flip up the Front Step (if so equipped).
- C.** On the right side of the mower, lift and hold up on the hook keeper. Lift up on the release handle to disconnect the back of the deck. The latch plate should catch and hold the release handle rod in place. (To adjust the latch plate, see page 21.)
- D.** Position the front caster wheels so they are away from the deck (such as the tractor would be traveling in reverse).
- E.** Lift the nose of the deck until the deck is standing near vertical (lifting can be made easier if someone stands on the rear bumper of the tractor).
- F.** Release the deck prop from its stowed position and place the free end against the deck lift casting as shown on page 19. Make sure the point of the prop falls within the center clearance area.

2. RETURNING THE DECK TO THE OPERATING POSITION:

- A.** Place the deck prop back in the stowed position.
- B.** Push the bottom (back) of the deck towards the rear of the tractor. Lower the deck until it rests on the ground.
- C.** Lift up on the latch plate to release the release handle rod. Push down on the release handle until deck hooks lock into place.
- D.** Install the engine to deck belt onto the clutch on the engine.
- E.** Ensure that the engine to deck drive belt is installed onto all of the pulleys and idlers in the drive train. Carefully rotate the Deck Belt Tension Latch to re-tension the Deck Belt.
- F.** Lower the foot deck down into the operation position. On units so equipped, lower the front step.

IMPORTANT NOTE:

TO SECURE THE DECK, MAKE SURE THAT THE DECK IS LIFTED FAR ENOUGH TO ALLOW THE DECK PROP TO ENGAGE THE DECK LIFT CASTING.

**MOWER SHOWN IN
OPERATING POSITION.**

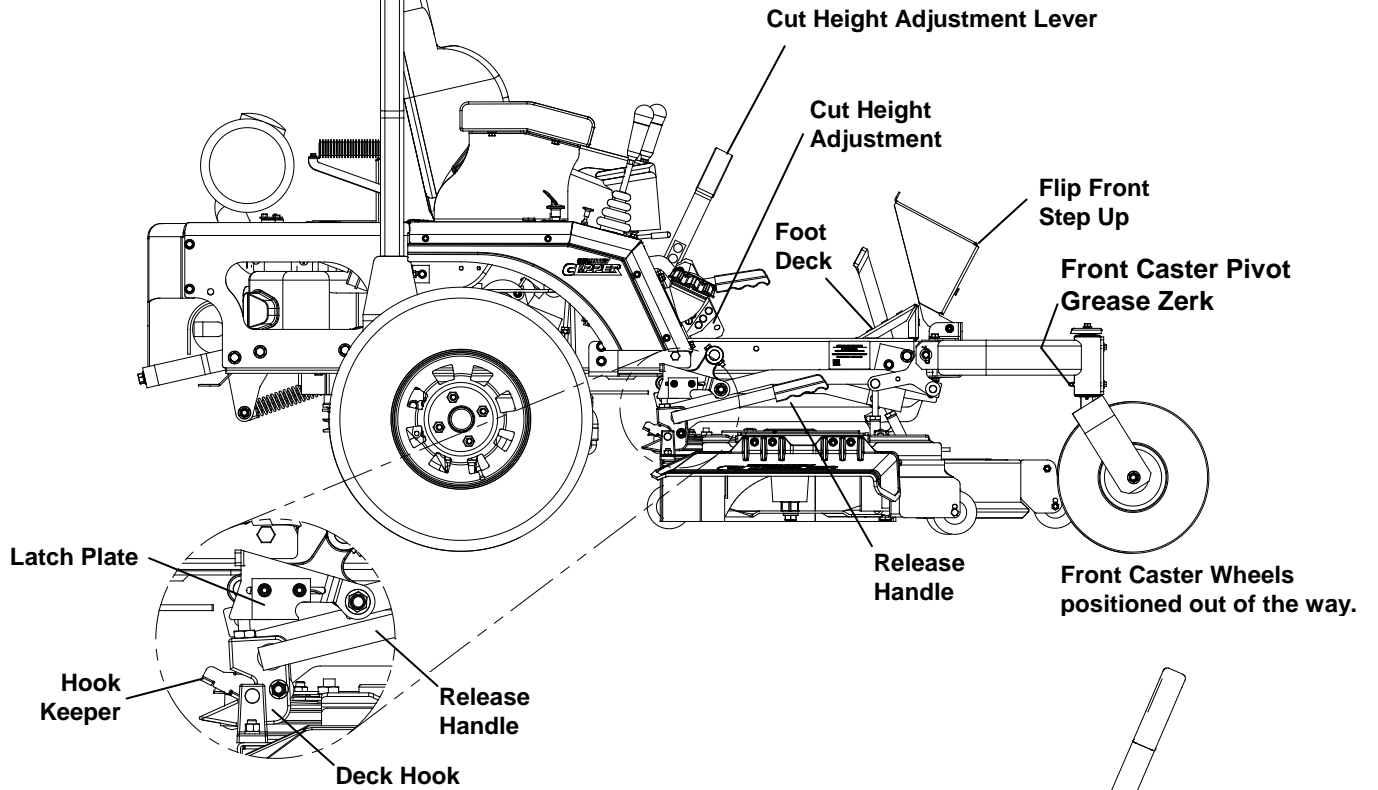

**MOWER SHOWN IN
SERVICING POSITION.**

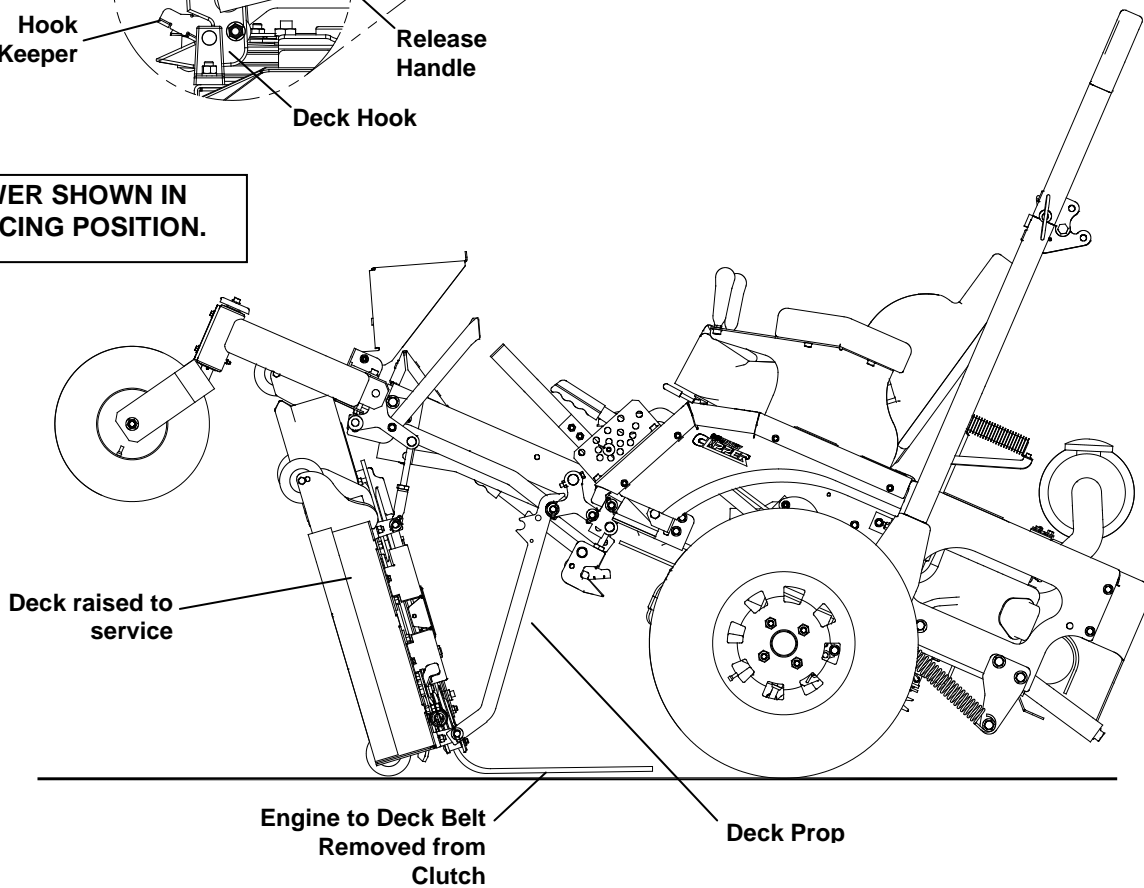

SECURING THE DECK PROP

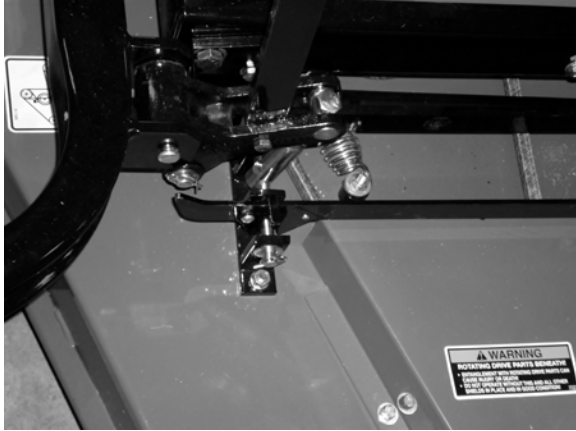

Deck Prop shown in the "Stowed" position.



Deck Prop being placed against the Deck lift casting.

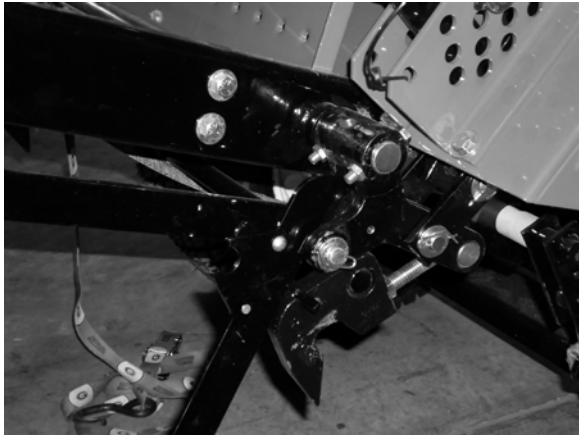

Deck Prop securely in place against Deck lift casting.

LEVELING THE DECK

NOTE: *The Deck has been leveled at the Factory.
If leveling is needed, use the following procedures.*

1. Move the tractor to a hard surface (i.e. concrete or blacktop).
2. Set the tire pressure on each of the four tires to 12-15 psi/83-103 kPa (make sure all four tires are equal).
3. Set the deck cutting height to the highest position and rotate the two outside blades by hand until one end of each outside blade points forward (toward the front of tractor).
4. Measure from the ground to the front blade tip of each outside blade. These measurements should be within 1/8" of each other. (NOTE: To simplify this measuring, an optional Blade Measuring tool, part Number 629-374A is available from your local "Country Clipper" Dealer).

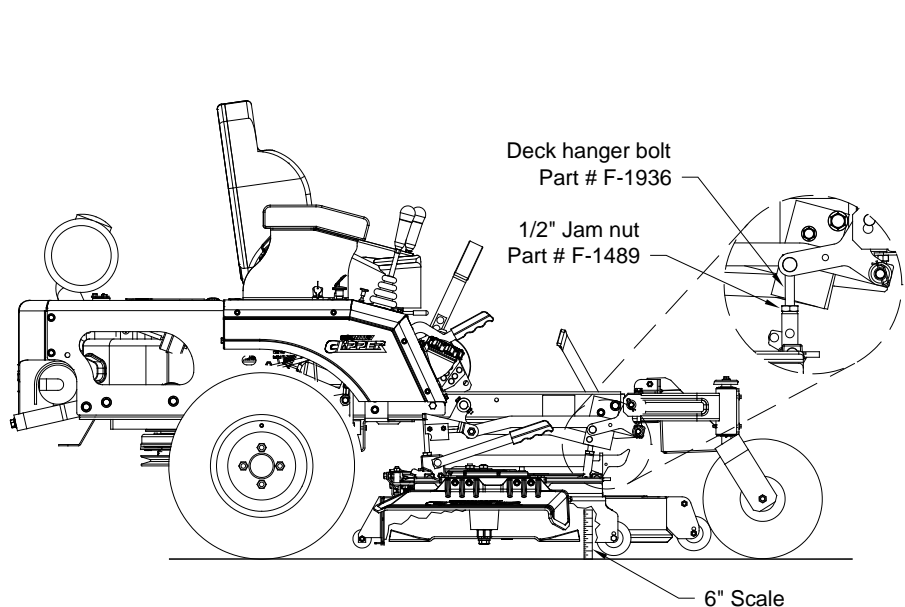

Note: If you run out of threads, remount the deck mounting in this upper hole.

IF ATTEMPTING TO ADJUST DECK HIGHER THAN DESIGN SPECIFICATIONS, DECK DRIVE FAILURE COULD OCCUR.

5. If adjustment is needed, loosen the jam nut(s) of the Deck Hanger Bolt(s) and adjust the Deck Hanger Bolt(s) up or down accordingly. It may be necessary to adjust both the front and rear Deck Hanger Bolts for a given side.
6. Once the side to side cut height is within tolerance, measure from the ground to the blade tip at the rear of each outside blade. This measurement should be between 1/8" and 1/4" higher from the ground than the front of the blade from the ground on the corresponding side of the deck. Adjust rear and/or the front deck hangers accordingly to obtain the proper measurement Re-measure the side to side cutting height to confirm that they are still within 1/8" of each other At the front of the blade.
7. Confirm that the deck is hanging firmly on ALL four deck hanger bolts. Readjust any loose Deck Hanger Bolts accordingly.
8. Once all of the above measurements are confirmed, tighten ALL jam nuts on the Deck Hanger Bolts. Failure to tighten can result in an un-level cutting deck and/or lost Deck Hanger Components.

ADJUSTING THE LATCH PLATE

1. Level the deck before proceeding to adjust the latch plate. (Follow instructions on previous page.) Pin the deck in the lowest position before proceeding to adjust the latch plate.
2. Lift up on the hook keeper, while pulling up on the release handle. This will disconnect the rear of the deck.
3. Loosen nuts on the adjustment of the latch plate using a 7/16 wrench. Pull up on the release handle as far as it will allow. Slide adjustment back or forward to where the latch plate will catch the release handle rod at its highest location. Tighten nuts back.
4. Lift up on latch plate and push down on the release handle to lock deck hooks in place.
5. Double check the latch plate adjustment by releasing the deck hangers and pulling up on the release handle. If the latch plate catches the release handle rod, no further adjustment needs to be made. If it does not, follow steps 3-5, as needed.

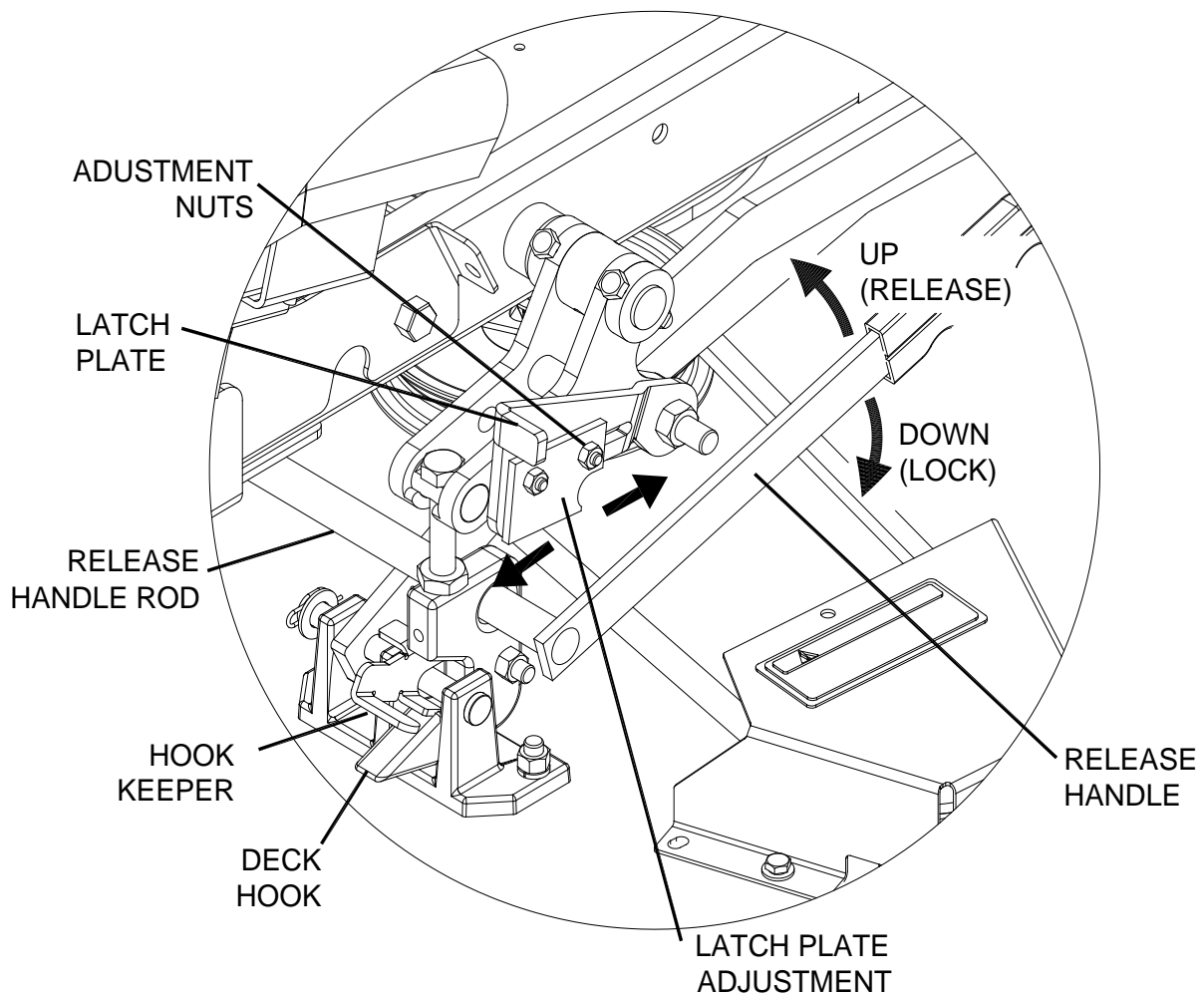

TROUBLE SHOOTING CHECK LIST

1. ENGINE WON'T TURN OVER:
 - Mower blades engaged ----- disengage blades
 - Drive not in neutral ----- move Control Lever(s) to neutral position
 - Blown fuse ----- replace fuse
 - Dead battery ----- charge or replace
 - Solenoid ----- consult dealer
 - Ignition switch ----- consult dealer
 - Starter ----- consult dealer

2. ENGINE WILL TURN OVER BUT WON'T START:
 - No gas ----- refuel
 - clean or replace fuel filters
 - Over or under choked ----- adjust choke
 - Spark plug not firing ----- check spark plug
 - condition and reset gap*
 - Carburetor maladjustment ----- reset carburetor adjustment*
 - Ignition switch ----- consult dealer

3. HARD TO START ENGINE:
 - Fuel line clogged ----- clean fuel line and check fuel filter
 - Faulty fuel pump ----- consult dealer
 - Spark plug wire loose or grounded ----- check spark plug wires
 - Spark plug(s) faulty or improperly gapped ----- check spark plug
 - condition and reset gap*
 - Electronic ignition defective ----- consult dealer
 - Dirty or maladjusted carburetor ----- readjust carburetor*
 - consult dealer for carburetor service

4. ENGINE STARTS BUT CUTS OUT:
 - Water in gasoline ----- drain old gasoline and replace with new gasoline
 - clean carburetor bowl
 - Clogged fuel line ----- check fuel filter
 - clean fuel line
 - Vent in fuel cap plugged ----- check vent
 - Faulty fuel pump ----- consult dealer
 - Maladjusted carburetor ----- readjust carburetor*
 - Engine dies when Control Lever(s) is move from "neutral" ----- parking brake set
 - release brake

5. ENGINE KNOCKS:
 - Low oil level ----- check and add oil
 - Ignition timing off ----- consult dealer
 - Fuel octane too low ----- drain and replace with
 - higher octane gasoline
 - Over heated engine ----- shut off engine and allow to cool

* See engine manual for engine adjustments.

6. ENGINE SOMETIMES SKIPS AT HIGHER SPEEDS:
 Incorrect Ignition Timing ----- consult dealer
 Carburetor maladjusted ----- readjust carburetor
 Faulty spark plugs ----- check spark plug
 condition and reset gap*
 Bouncing off seat safety switch ----- slow down on rough terrain
7. ENGINE OVER HEATED:
 Air intake screen or fins clogged ----- clean intake screen and fins
 Fuel mixture too lean ----- readjust carburetor*
 Oil level too low or too high ----- adjust oil level
 Improper ignition timing ----- consult dealer
 Running engine too slow ----- run engine faster
 (NOTE: Always mow at full throttle setting.)
8. ENGINE IDLES POORLY:
 Carburetor maladjustment ----- readjust carburetor
 Improper spark plug gap ----- check and re-gap*
9. ENGINE BACKFIRES:
 Carburetor maladjustment ----- readjust carburetor*
10. ENGINE RUNS BUT MOWER WON'T MOVE FORWARD:
 Transmission locks in free wheel position ----- put in lock position (see pg. 10)
 Drive belt broken or slipping ----- replace drive belt
 Shift linkage disconnected ----- reconnect
 Transmission oil low ----- consult dealer
 Bad transmission ----- consult dealer
11. TRANSMISSION LOSES POWER OR TRANSMISSIONS OVER HEATS:
 Transmission damage ----- consult dealer
12. MOWER TRANSMISSION DOES NOT ENGAGE RIGHT AND/OR LEFT HAND:
 Transmission Free Wheel engaged ----- disengage Free Wheel
 Loose or damage Control Linkage ----- consult dealer
 Low Transmission oil ----- consult dealer
13. ENGINE STALLS WHEN BLADES ARE ENGAGED:
 Operator not on seat ----- sit on seat
 Faulty interlock system ----- consult dealer
 Bad blade spindle bearing ----- consult dealer
 Deck drive belt not properly routed ----- reroute
 Blades blocked by foreign material ----- clean under deck
14. DECK BLADES WILL NOT ENGAGE:
 Blown fuse ----- replace fuse
 Faulty wiring ----- consult dealer
 Faulty electric clutch ----- consult dealer

* See engine manual for engine adjustments.

BELT ROUTINGS

Hydrostatic Transmission Drive Belt (Viewed from ground looking up)

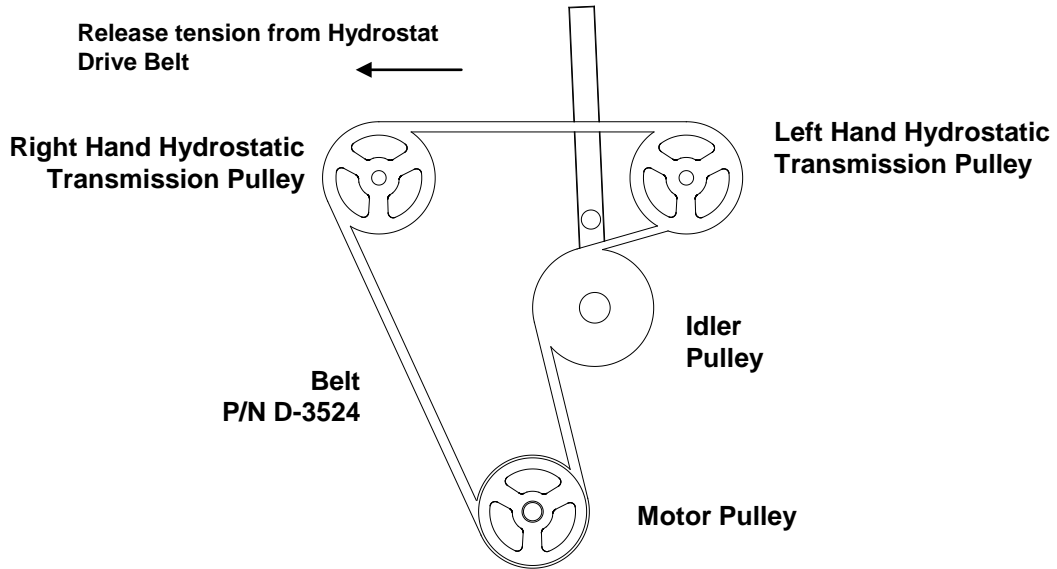

Deck Drive Belt

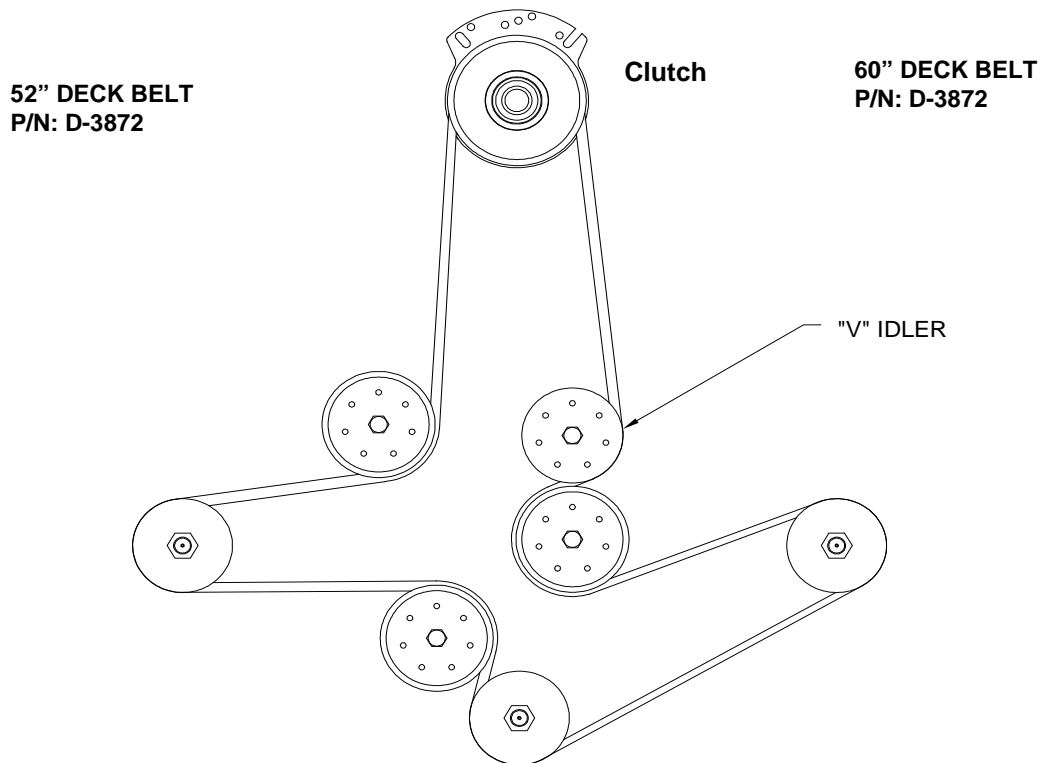

WIRING SCHEMATIC FOR KAWASAKI TWINSTICK (E-6416) PLUS (E-6417) ADAPTER

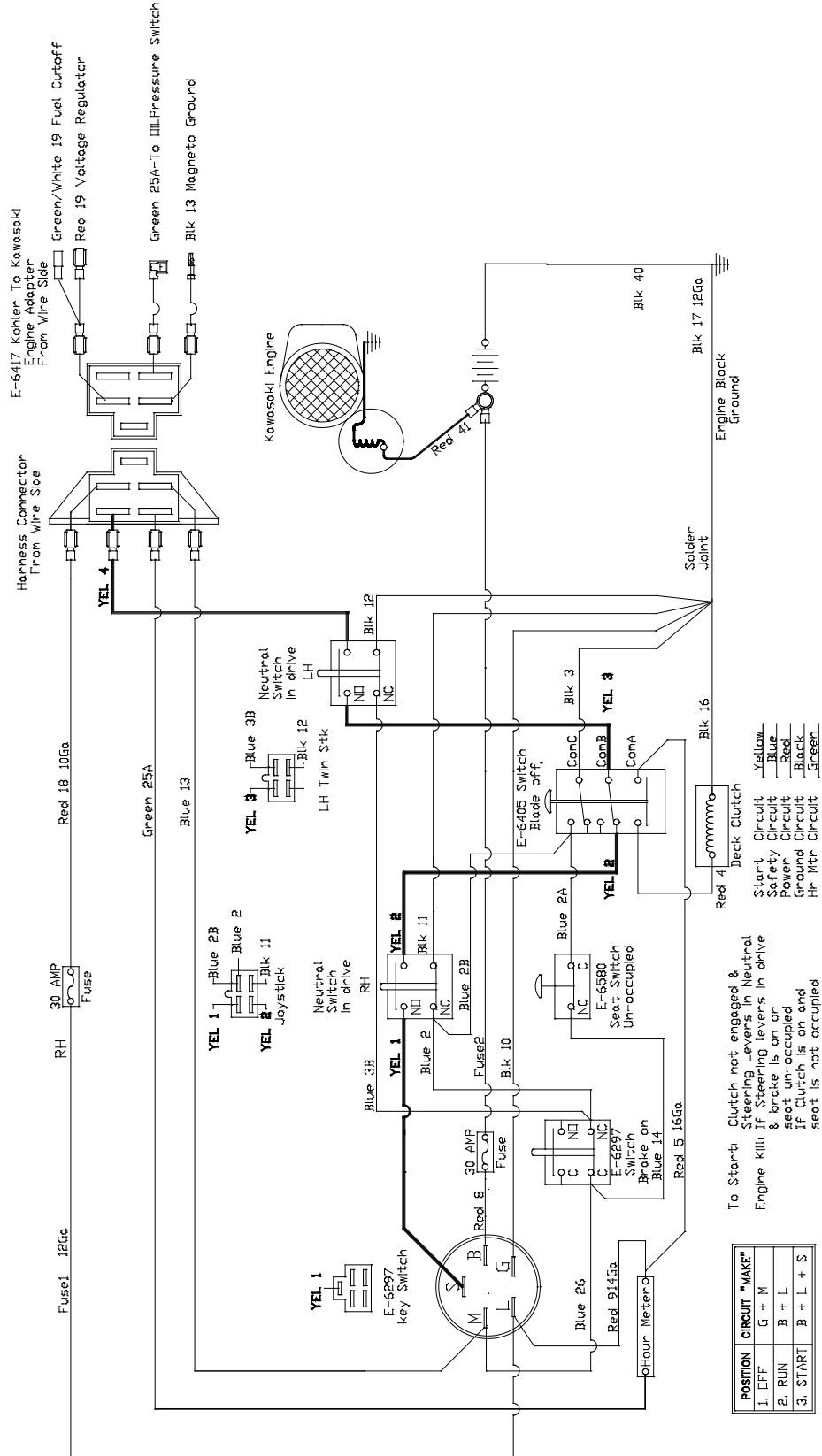

WIRING SCHEMATIC FOR KOHLER TWINSTICK (E-6416) PLUS (E-6547) ADAPTER

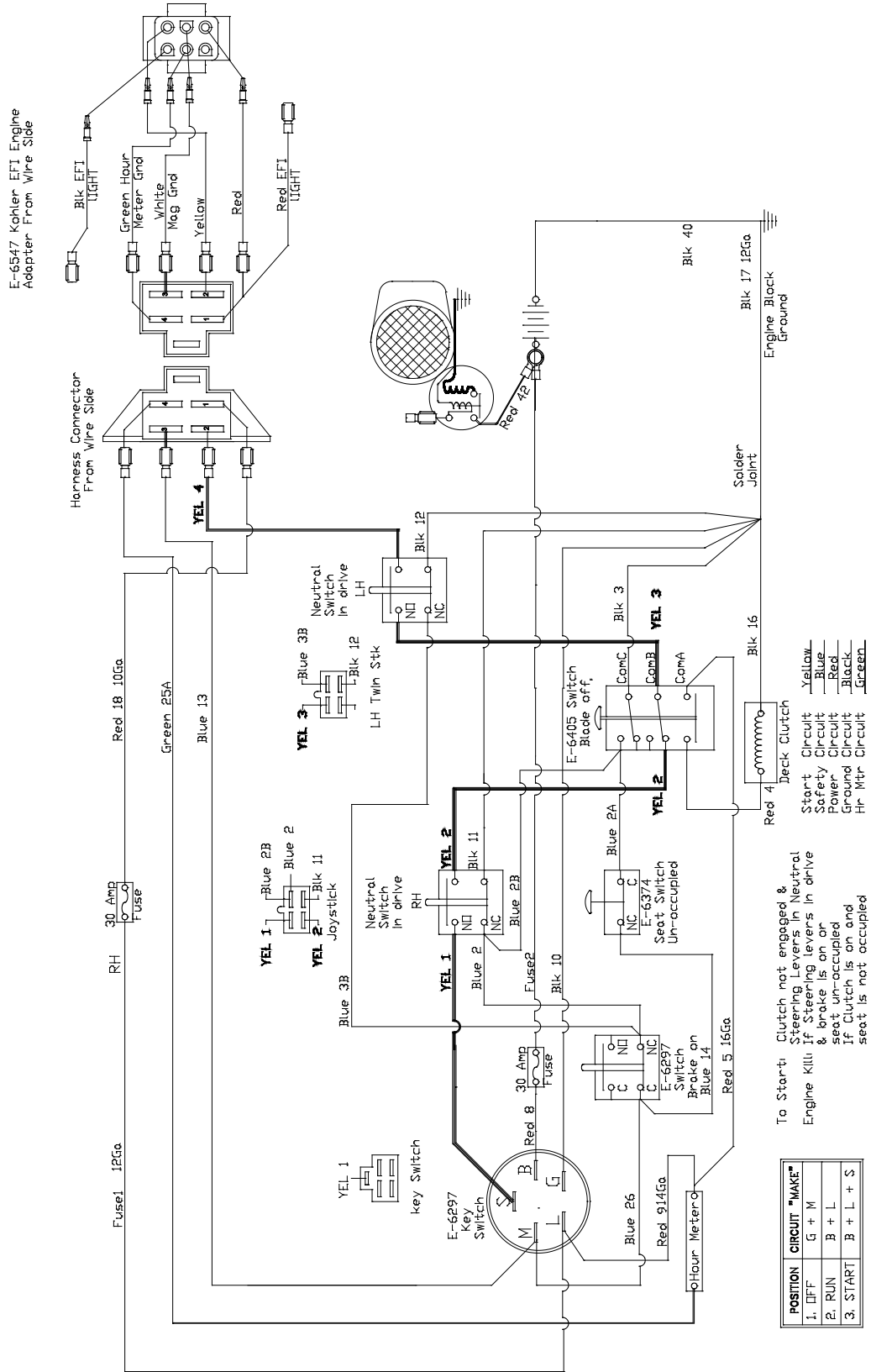

HYDRAULIC SCHEMATIC:

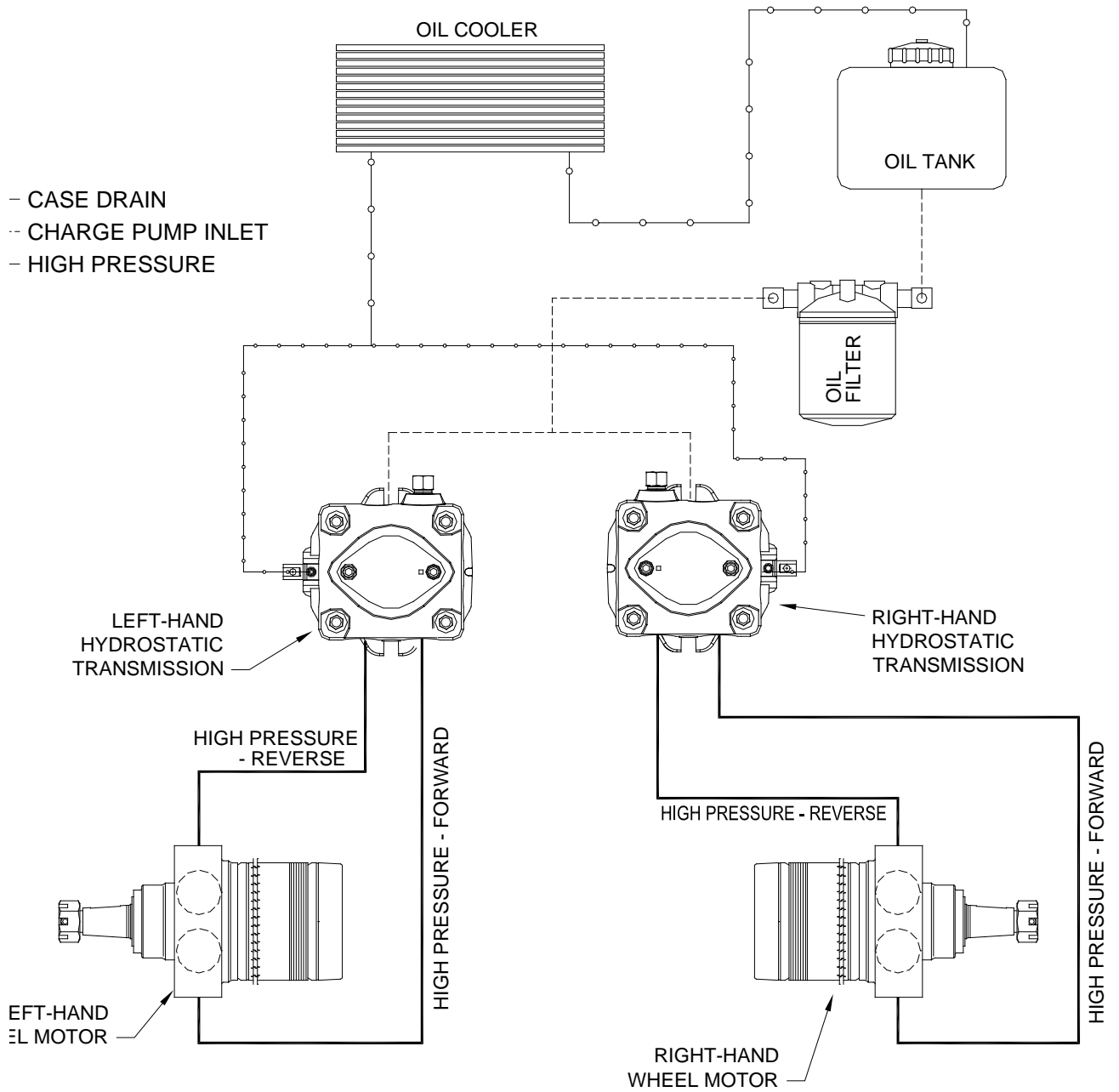

Safety Instructions & Operators Manual



CHARGER™

1050/1055

Country Clipper Division
Shivvers Manufacturing Inc.
613 W. English St.
Corydon, IA 50060-0467
Ph. 641-872-2544
Fax. 641-872-1593