

# Repair Parts Manual

**COUNTRY**  
**CLIPPER**®  
ZERO TURN MOWER

**CHALLENGER**™

515

Congratulations for buying a **Country Clipper** product. Your **Country Clipper** Zero Turn Radius Riding Mower was designed and built to provide long and trouble free service. Keep in mind that it, like any other mechanical device, can be potentially dangerous if used improperly, and hazard control and accident prevention are dependent upon the awareness, concern, prudence, and proper training of personnel involved in the operation, transport, maintenance, and storage of the equipment. Study this manual and pay special attention to the important Safety Precautions on pages 3-5. Following these instructions will help you continue to enjoy the trouble-free performance expected of the **Country Clipper** product.



# COUNTRY CLIPPER

# CHALLENGER

## 515

## ZERO TURN RADIUS MOWER

### TABLE OF CONTENTS

#### SECTION 1 – MOWER DECKS AND RELATED PARTS

1. 52" MEDIUM DECK ASSEMBLY
2. 60" MEDIUM DECK ASSEMBLY
3. DECK SPINDLE ASSEMBLY
4. DOUBLE IDLER & RELATED PARTS 52" DECK
5. DOUBLE IDLER & RELATED PARTS 60" DECK
6. STATIONARY IDLERS & RELATED PARTS
7. MOLDED CHUTE ASSEMBLY
8. LIFT HANDLE ASSEMBLY & RELATED PARTS
9. LIFT ASSEMBLY & RELATED PARTS
10. TRANSMISSION IDLERS & RELATED PARTS

#### SECTION 2 – TRACTOR FRAME AND RELATED PARTS

11. CASTER WHEEL ASSEMBLY
12. FRAME SIDES & RELATED PARTS
13. FENDER ASSEMBLY
14. SEAT, FOOT DECK ASSEMBLY & RELATED PARTS
15. SEAT, FOOT DECK ASSEMBLY & RELATED PARTS (CON'T)
16. FRONT STEP ASSEMBLY

#### SECTION 3 – TRACTOR DRIVE AND RELATED PARTS

17. FUEL TANK ASSEMBLY
18. JOYSTICK STEERING CONTROL & RELATED PARTS
19. JOYSTICK ASSEMBLY
20. JOYSTICK STEERING CONTROL & RELATED PARTS (CON'T)
21. PARKING BRAKE ASSEMBLY & RELATED PARTS
22. MOTOR ASSEMBLY & RELATED PARTS - 24HP KAWASAKI
23. MOTOR ASSEMBLY & RELATED PARTS - 25HP KOHLER
24. MOTOR ASSEMBLY & RELATED PARTS - 27HP BRIGGS & STRATTON
25. E-6415 WIRE HARNESS ASSEMBLY & RELATED PARTS
26. E-6417 WIRE HARNESS ASSEMBLY & RELATED PARTS - KAWASAKI
27. E-6436 WIRE HARNESS ADAPTER & RELATED PARTS - BRIGGS

# 52" MED DECK ASSEMBLY {660AM-002A}

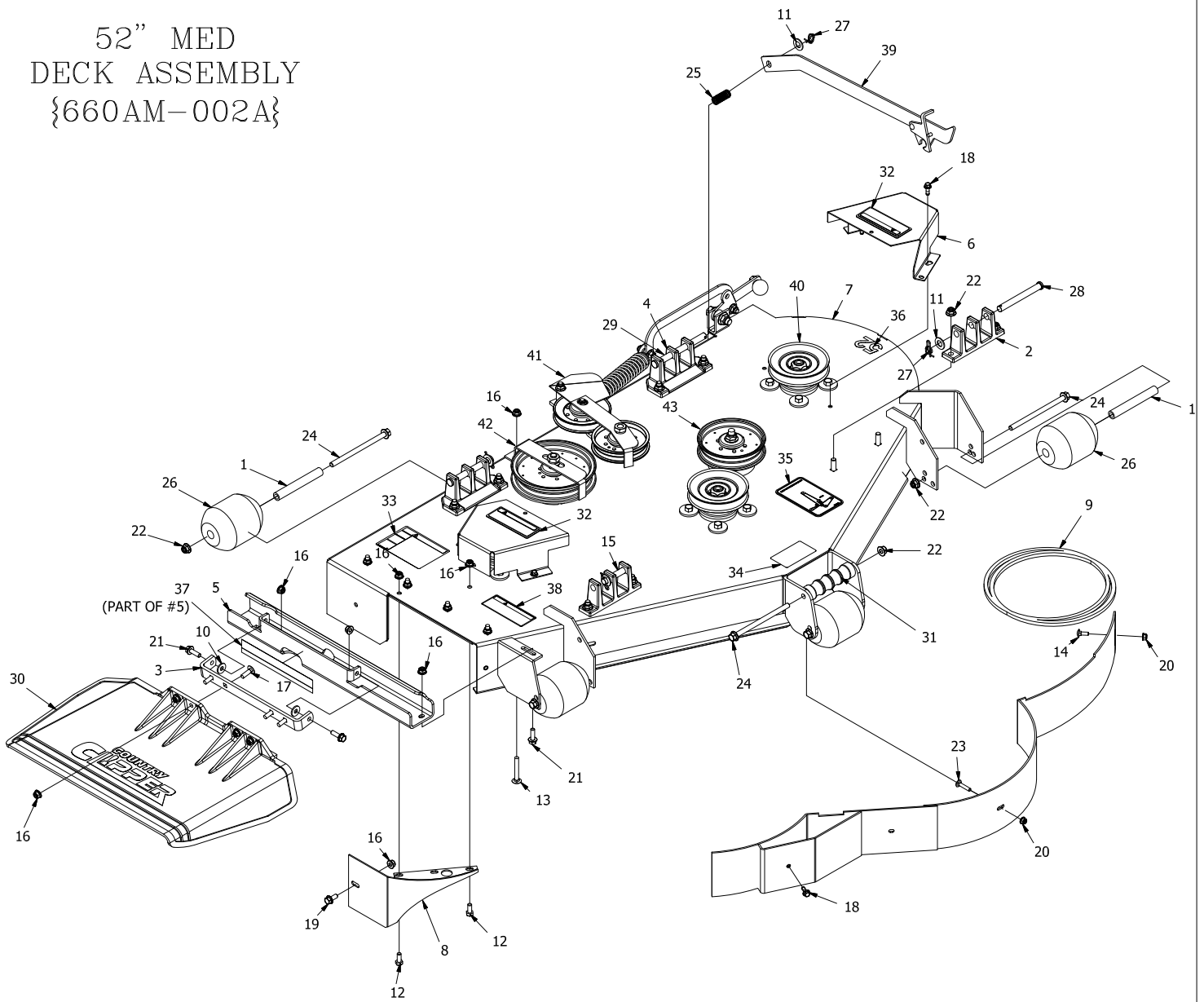

REF NO.	PART NO.	QTY.	DESCRIPTION	REF NO.	PART NO.	QTY.	DESCRIPTION
1	609-183P	5	BUSHING	23	F-2157	1	CARRIAGE BOLT, 1/4 X 1-1/4"
2	643-016W	2	Hanger Weldment	24	F-2161	6	FHCS, 3/8-16 x 6", YZ, GR5
3	643-110P	1	CHUTE HINGE	25	F-2575	1	SPRING, COMP .656 X .052 X 1.97
4	651-009W	2	CASTING,HANGER,WIDE BASE	26	H-1948	5	Roller, 3-3/4 DIA. x 4-13/16L
5	643-135A	1	OUTLET STIFFENER w/DECAL	27	H-2239	4	1/2" Rue Ring
6	660-146A	2	PULLEY COVER w/DECALS	28	H-2240	2	1/2" x 4-1/2" Clevis Pin
7	660-188A	1	52 MED. DECK WLDT w/DECALS	29	H-2718	1	1/2" x 5-1/2" Clevis Pin
8	686-080W	1	SPLITTER BAFFLE	30	H-2723	1	Chute, Discharge, Small
9	D-3872	1	BELT, B-184	--	643-111A	1	CHUTE ASSEMBLY, SMALL
10	F-1009-02	2	5/16" Flat Washer	31	H-2787	1	GRIP, DECK HANDLE
11	F-1521	6	1/2" WASHER, CUSTOM	32	P-10935	2	Decal, WARNING
12	F-1546	2	5/16-18 x 3/4" Capscrew	33	P-10941	1	DECAL "DANGER ROTATING BLADES"
13	F-1707	1	5/16-18 x 2 1/4" CARRIAGE BOLT,	34	P-11413	1	DECAL, HOIST POINT
14	F-1823	1	Carriage Bolt, 1/4 X 3/4"	35	P-11932	1	DECAL, JAZEE DECK BELT ROUTING
15	F-1889	1	1/2 x 2-5/8" Clevis Pin	36	P-11951	1	DECAL, DECK SIZE, 52
16	F-2063	15	Nut, 5/16-18 Nyloc, Flanged	37	P-12496	1	DECAL, MISSING CHUTE
17	F-2066	4	5/16-18 x 1" CARRIAGE BOLT,	38	P-12706	1	WARNING DECAL, DISCHARGE CHUTE
18	F-2119	5	FHCS, 1/4-20 x 0.75, YZ, LOCK PATCH, GR5	39	625-114A	1	DECK PROP ASS'Y, EDGE XLT
19	F-2120	1	FHCS, 5/16-18 x 0.75, YZ, GR5	40	-----	3	SPINDLE ASS'Y (SEE pg.3)
20	F-2132	2	NUT, 1/4-20 NYLOC, FLANGED	41	-----	1	DOUBLE IDLER ASS'Y (SEE pg.4)
21	F-2148	3	FHCS, 5/16-18 x 1.00, YZ, GR5	42	-----	1	REAR IDLER ASS'Y (SEE pg.6)
22	F-2151	21	Nut,3/8-16 Nyloc, Flanged	43	-----	1	FRONT IDLER ASS'Y (SEE pg.6)

60" MED  
DECK ASSEMBLY  
{660AJ-002A}

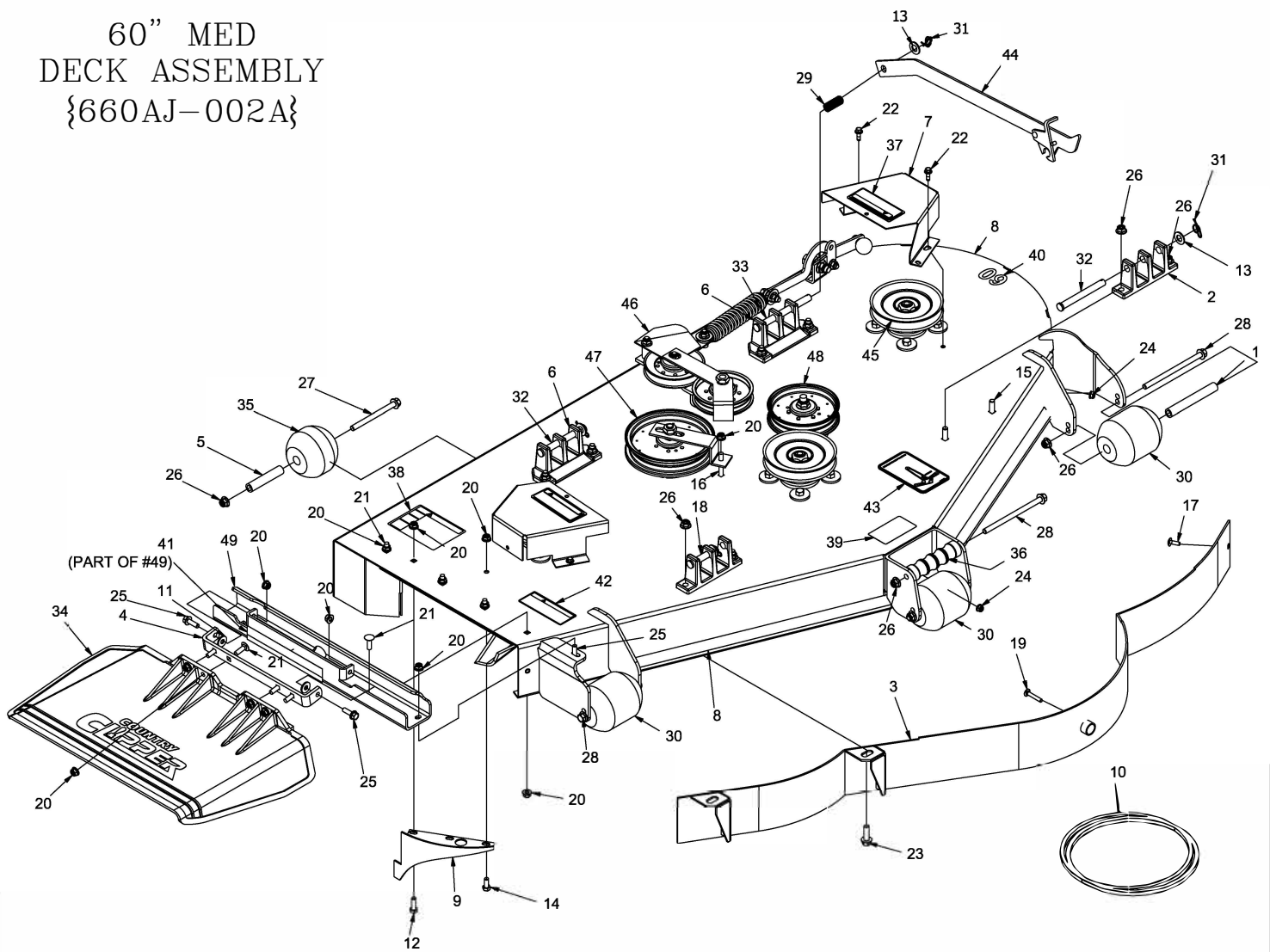

REF NO.	PART NO.	QTY.	DESCRIPTION	REF NO.	PART NO.	QTY.	DESCRIPTION
1	609-183P	3	BUSHING	26	F-2151	21	Nut, 3/8-16 Nyloc, Flanged
2	643-016W	2	Hanger Weldment	27	F-2160	2	FHCS, 3/8-16 x 4 1/2", YZ, GR5
3	643-104W	1	60" DUST BAFFLE WELDMENT	28	F-2161	4	FHCS, 3/8-16 x 6", YZ, GR5
4	643-110P	1	CHUTE HINGE	29	F-2575	1	SPRING, COMP .656 X .052 X 1.97
5	643-126P	2	BUSHING	30	H-1948	3	Roller, 3-3/4 DIA. x 4-13/16L
6	651-009W	2	CASTING, HANGER, WIDE BASE	31	H-2239	4	1/2" Rue Ring
7	660-146A	2	PULLEY COVER w/DECALS	32	H-2240	2	1/2" x 4-1/2" Clevis Pin
8	660-189A	1	60 MED DECK WLDT w/DECALS	33	H-2718	1	1/2" x 5-1/2" Clevis Pin
9	686-006W	1	SPLITTER BAFFLE	34	H-2723	1	Chute, Discharge, Small
10	D-3914	1	BELT, BANDO " B-180"	-	643-111A	1	CHUTE ASSEMBLY, SMALL
11	F-1009-02	2	5/16" Flat Washer	35	H-2772	2	Roller, 3-3/4 DIA. x 3 1/4"L
12	F-1015-15	1	5/16-18 x 1" Capscrew	36	H-2787	1	GRIP, DECK HANDLE
13	F-1521	6	1/2" WASHER, CUSTOM	37	P-10935	2	Decal, WARNING
14	F-1546	1	5/16-18 x 3/4" Capscrew	38	P-10941	1	DECAL "DANGER ROTATING BLADES"
15	F-1672	7	3/8-16 x 1-1/4" Carriage Bolt	39	P-11413	1	DECAL, HOIST POINT
16	F-1707	1	5/16-18 x 2 1/4" CARRIAGE BOLT,	40	P-11952	1	DECAL, DECK SIZE, 60
17	F-1823	1	Carriage Bolt, 1/4 X 3/4"	41	P-12496	1	DECAL, MISSING CHUTE
18	F-1889	1	1/2 x 2-5/8" Clevis Pin	42	P-12706	1	WARNING DECAL, DISCHARGE CHUTE
19	F-1935	1	CARRIAGE BOLT, 1/4 X 1-1/2"	43	P-12837	1	DECAL, DECK BELT ROUTING
20	F-2063	14	Nut, 5/16-18 Nyloc, Flanged	44	625-114A	1	DECK PROP ASS'Y, EDGE XLT
21	F-2066	8	5/16-18 x 1" CARRIAGE BOLT,	45	-----	3	SPINDLE ASS'Y (SEE pg.3)
22	F-2119	4	FHCS, 1/4-20 x 0.75, YZ, LOCK PATCH, GR5	46	-----	1	DOUBLE IDLER ASS'Y (SEE pg.5)
23	F-2125	2	FHCS, 3/8-16 x 1.25, YZ, GR5	47	-----	1	REAR IDLER ASS'Y (SEE pg.6)
24	F-2132	2	NUT, 1/4-20 NYLOC, FLANGED	48	-----	1	FRONT IDLER ASS'Y (SEE pg.6)
25	F-2148	3	FHCS, 5/16-18 x 1.00, YZ, GR5	49	643-135A	1	OUTLET STIFFENER w/DECAL

TORQUE TO 140 ft-lb

# DECK SPINDLE ASSEMBLY 629FN-001A

PULLEY NOT INCLUDED \*2  
IN ASSEMBLY

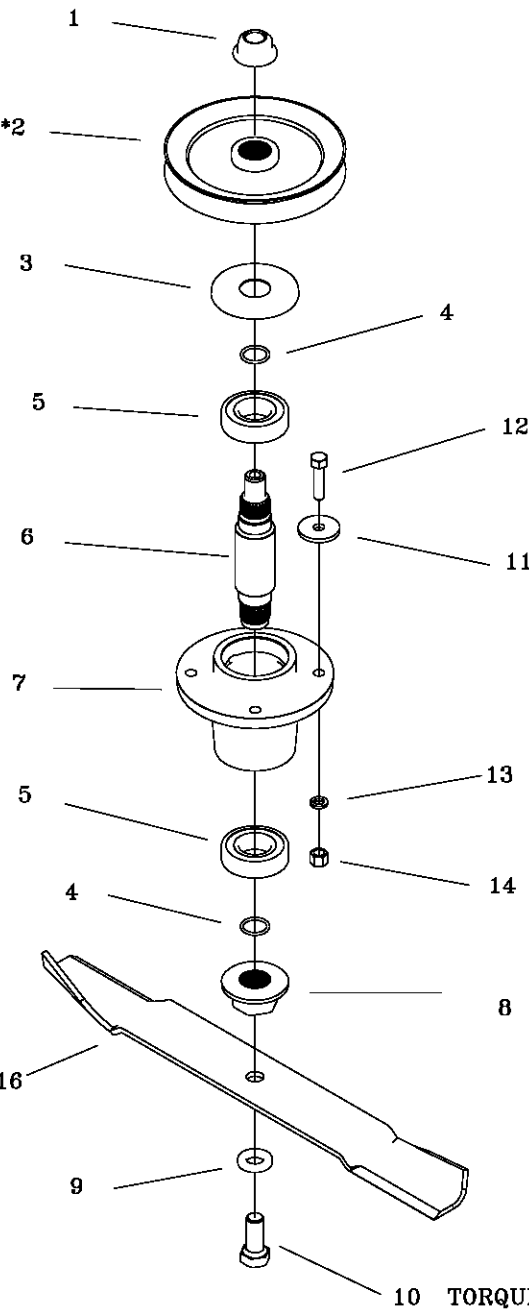

BLADE NOT INCLUDED \*16  
IN ASSEMBLY

15 (APPLY THIN LAYER OF CHEVRON RYKOTAC GREASE TO THE TOP SURFACES OF THE BEARING AND HOUSING PRIOR TO INSTALLING ITEM #3 (BEARING CAP).  
  
NEW MOWERS ARE SHIPPED WITH 3 to 4 oz OF CHEVRON SRI NLGI 2 GREASE INSIDE EACH SPINDLE HOUSING.

10 TORQUE TO 100 ft-lb

REF NO.	PART NO.	QTY.	DESCRIPTION	REF NO.	PART NO.	QTY.	DESCRIPTION
1	F-2078	1	3/4-6 TOP LOCK NUT	15	H-2707	1	GREASE PACKET
	668-038P	*	52" DECK CENTER PULLEY	16	H-2883	-	BLADE, HIGH L, 18 3/8" CUT 52"
*	668-039P	*	60" DECK CENTER PULLEY		H-2885	-	BLADE, HIGH L, 21" CUT 60"
3	609-292P	1	CAP, BEARING	OPTIONAL BLADES			
4	H-2639	2	O'RING, RUBBER				
5	D-3867	2	BEARING, #6206				
6	609-289P	1	SHAFT, SPINDLE				
7	609-285P	1	HOUSING, SPINDLE				
8	609-288P	1	BLADE DRIVER				
9	660-099P	1	BLADE WASHER				
10	F-2073	1	5/8-11 X 1.5 HHCS GR. 8				
11	609-034P	4	SPINDLE SPACER, WASHER		H-2660	-	BLADE, LOW L, 18 3/8" CUT, 52"
12	F-1572	4	3/8-24 X 1.5 CAP SCREW		H-2661	-	BLADE, LOW L, 21" CUT, 60"
13	F-1019-03	4	3/8 LOCK WASHER		H-2666	-	BLADE, GATOR, 18 3/8" CUT 52"
14	F-1573	4	3/8-24 LOCK NUT		H-2667	-	BLADE, GATOR, 21" CUT 60"

# DOUBLE IDLER DRIVE BELT IDLER & RELATED PARTS 52" MED DECK

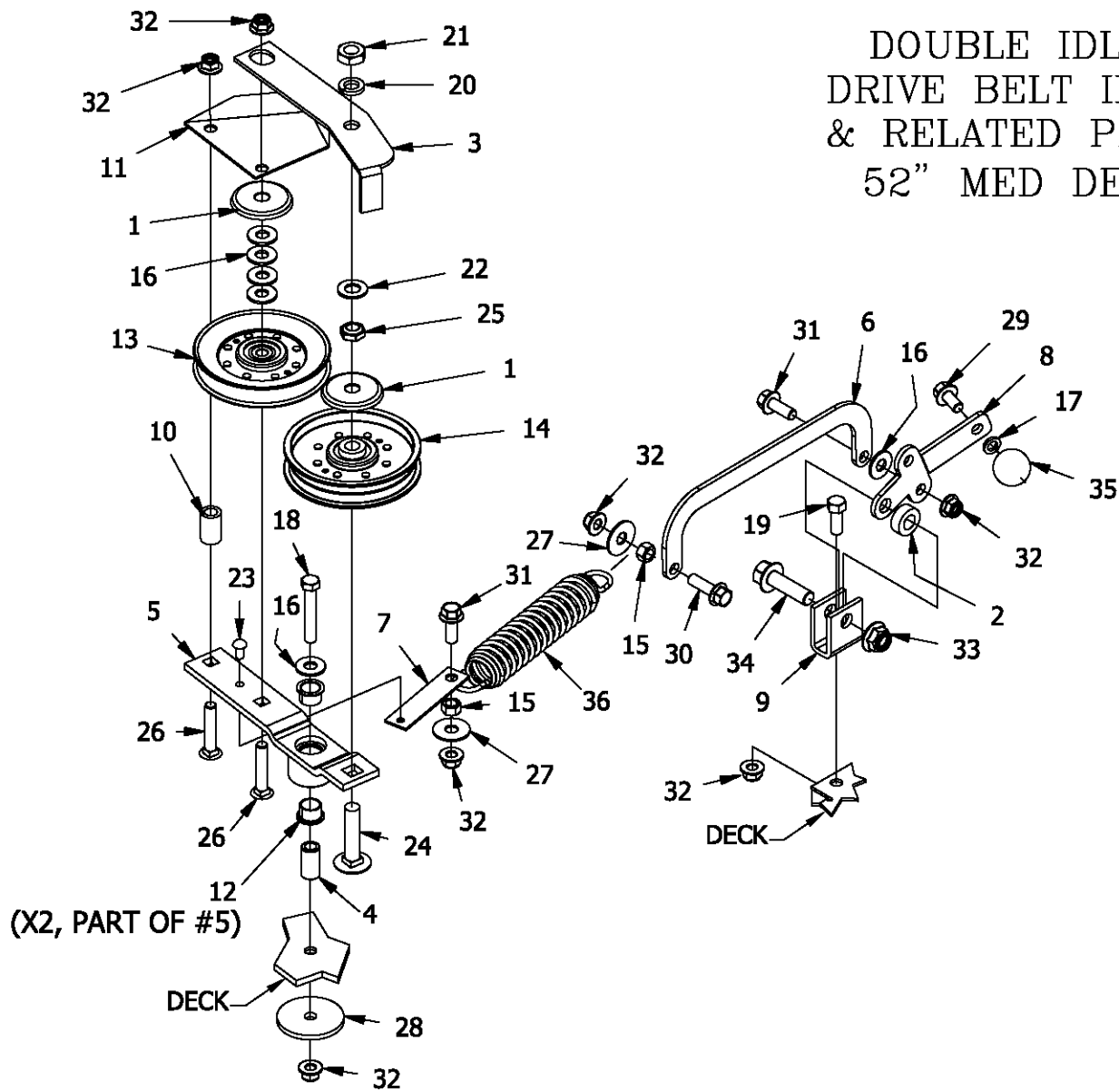

REF NO.	PART NO.	QTY.	DESCRIPTION	REF NO.	PART NO.	QTY.	DESCRIPTION
1	620-201P	4	WASHER, BEARING CAP	19	F-1394	1	3/8-16 x 1" Capscrew
2	660-038P	1	3/8" Spacer	20	F-1464	2	1/2" LOCKWASHER
3	660-107P	1	BELT KEEPER	21	F-1489	2	1/2-13 Hex Jam Nut
4	660-135P	1	MOUNTING PIN	22	F-1521	6	1/2" WASHER, CUSTOM
5	660-147A	1	IDLER ARM ASSEMBLY	23	F-1733	1	1/4" x 1/2" DRIVE SCREW
6	660-172P	1	LINK, BELT TENSION	24	F-1822	1	1/2-13 X 2-1/4" CARRIAGE BOLT
7	660-173P	1	SPRING EXTENSION	25	F-1966	2	1/2-13 THIN NYLOC NUT
8	660-184P	1	HANDLE, BELT TENSIONER	26	F-1976	2	3/8-16 x 2" Carraige Bolt
9	661-015P	1	SHACKLE	27	F-2083	2	WASHER, 3/8 FENDER
10	668-021P	1	SPACER, BELT GUARD	28	F-2102	1	WASHER.406ID X 2.25OD X 7GA THK
11	668-029P	1	BELT GUARD	29	F-2124	1	FHCS, 3/8-16 x 0.75, YZ, GR5
12	D-3730	2	FLANGED BUSHING	30	F-2125	1	FHCS, 3/8-16 x 1.25, YZ, GR5
13	D-3923	1	PULLEY, V-IDLER, 4.59 OD, AB, NTN	31	F-2141	2	FHCS, 3/8-16 x 1", YZ, GR5
14	D-3924	1	PULLEY, FLAT IDLER, NTN, DBL INSERT	32	F-2151	21	Nut,3/8-16 Nyloc, Flanged
15	F-1005-03	2	3/8-16 Stover Nut	33	F-2152	2	Nut,1/2-13 Nyloc, Flanged
16	F-1009-03	6	3/8" Flat Washer	34	F-2154	1	FHCS, 1/2-13 x1-3/4", YZ, GR5
17	F-1019-03	13	3/8" LOCKWASHER	35	H-2405	1	BALL, 1-1/4"
18	F-1268	1	3/8-16 x2-1/4" Capscrew	36	H-2619	1	SPRING,5 X 1-1/2,TAPERED ENDS

DOUBLE IDLER  
DRIVE BELT IDLER  
& RELATED PARTS  
60" MED DECK

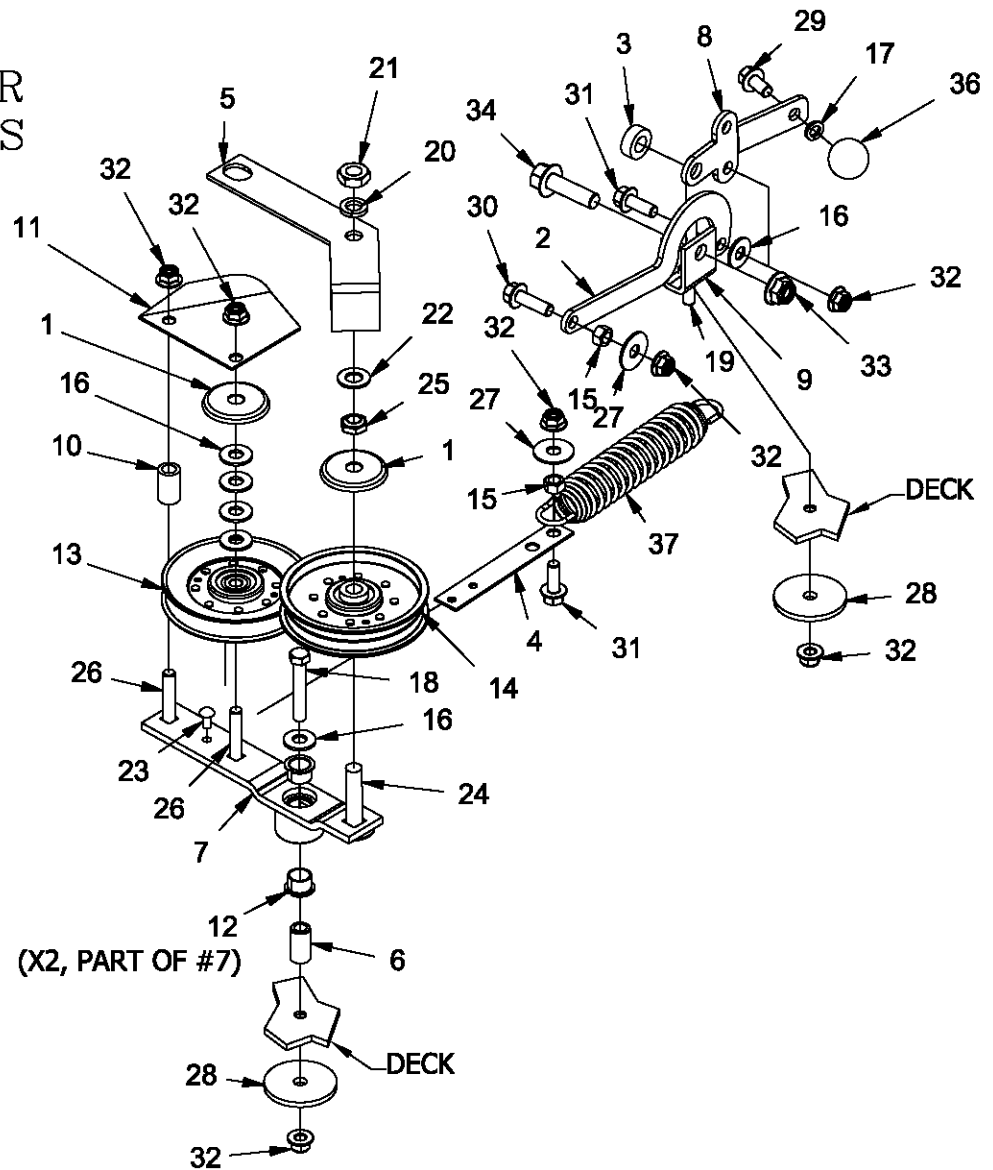

REF NO.	PART NO.	QTY.	DESCRIPTION	REF NO.	PART NO.	QTY.	DESCRIPTION
1	620-201P	4	WASHER, BEARING CAP	20	F-1464	2	1/2" LOCKWASHER
2	660-031P	1	Belt Tightner Arm	21	F-1489	2	1/2-13 Hex Jam Nut
3	660-038P	1	3/8" Spacer	22	F-1521	6	1/2" WASHER, CUSTOM
4	660-081P	1	EXTENSION FOR SPRING	23	F-1733	1	1/4" x 1/2" DRIVE SCREW
5	660-110P	1	BELT KEEPER, B BELT	24	F-1822	1	1/2-13 X 2-1/4" CARRIAGE BOLT
6	660-135P	1	MOUNTING PIN	25	F-1966	2	1/2-13 THIN NYLOC NUT
7	660-147A	1	IDLER ARM ASSEMBLY	26	F-1976	2	3/8-16 x 2" Carraige Bolt
8	660-184P	1	HANDLE, BELT TENSIONER	27	F-2083	2	WASHER, 3/8 FENDER
9	661-015P	1	SHACKLE	28	F-2102	2	WASHER.406ID X 2.25OD X 7GA THK
10	668-021P	1	SPACER, BELT GUARD	29	F-2124	1	FHCS, 3/8-16 x 0.75, YZ, GR5
11	668-029P	1	BELT GUARD	30	F-2125	2	FHCS, 3/8-16 x 1.25, YZ, GR5
12	D-3730	2	FLANGED BUSHING	31	F-2141	2	FHCS, 3/8-16 x 1", YZ, GR5
13	D-3923	1	PULLEY, V-IDLER, 4.59 OD, AB, NTN	32	F-2151	21	Nut,3/8-16 Nyloc, Flanged
14	D-3924	1	PULLEY, FLAT IDLER, NTN, DBL INSERT	33	F-2152	2	Nut,1/2-13 Nyloc, Flanged
15	F-1005-03	2	3/8-16 Stover Nut	34	F-2154	1	FHCS, 1/2-13 x1-3/4", YZ, GR5
16	F-1009-03	6	3/8" Flat Washer	35	H-2239	4	1/2" Rue Ring
17	F-1019-03	13	3/8" LOCKWASHER	36	H-2405	1	BALL, 1-1/4"
18	F-1268	1	3/8-16 x2-1/4" Capscrew	37	H-2619	1	SPRING,5 X 1-1/2,TAPERED ENDS
19	F-1394	1	3/8-16 x 1" Capscrew				



## RIGHT REAR STATIONARY IDLER ASSEMBLY

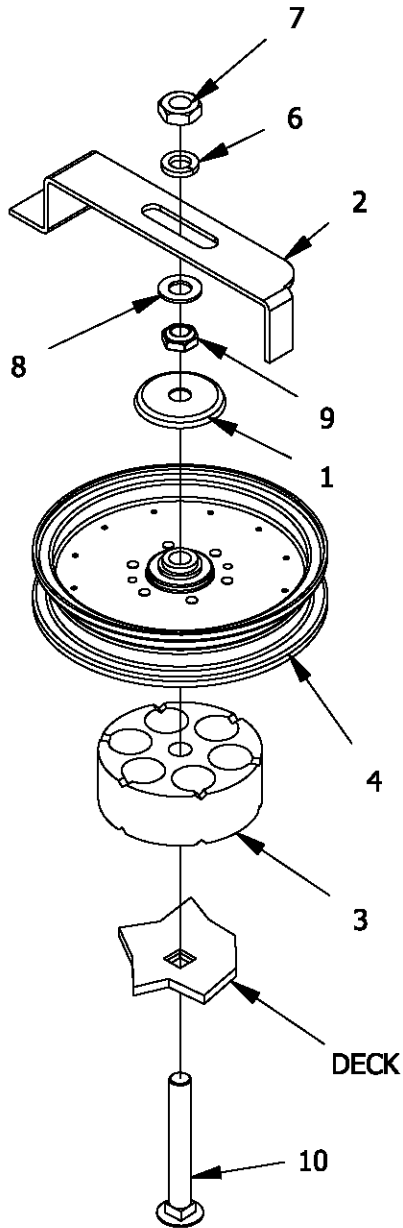

## FRONT STATIONARY IDLER ASSEMBLY

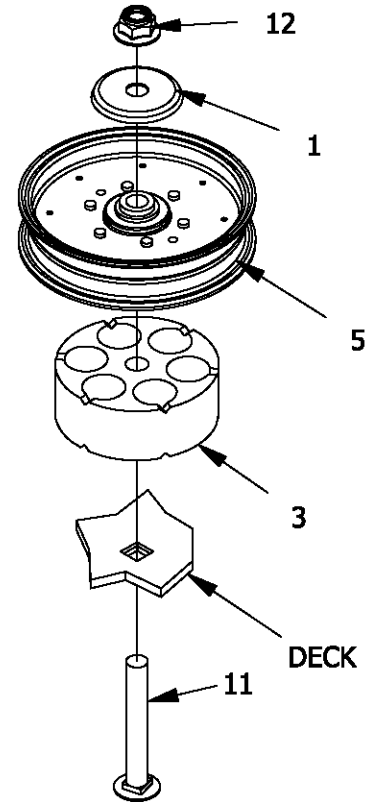

REF NO.	PART NO.	QTY.	DESCRIPTION	REF NO.	PART NO.	QTY.	DESCRIPTION
1	620-201P	4	WASHER, BEARING CAP	7	F-1489	2	1/2-13 Hex Jam Nut
2	660-112P	1	BELT KEEPER	8	F-1521	6	1/2" WASHER, CUSTOM
3	660-148P	2	SPACER, IDLER MOUNT	9	F-1966	2	1/2-13 THIN NYLOC NUT
4	D-3903	1	PULLEY, FLAT IDLER, 6" (NTN)	10	F-2079	1	CARRIAGE BOLT 1/2-13 X 3-3/4"
5	D-3904	1	PULLEY, FLAT IDLER, 5" (NTN)	11	F-2106	1	1/2-13 X 3-1/2" CARRIAGE BOLT
6	F-1464	2	1/2" LOCKWASHER	12	F-2152	2	Nut, 1/2-13 Nyloc, Flanged

# MOLDED CHUTE ASSEMBLY {643-111A}

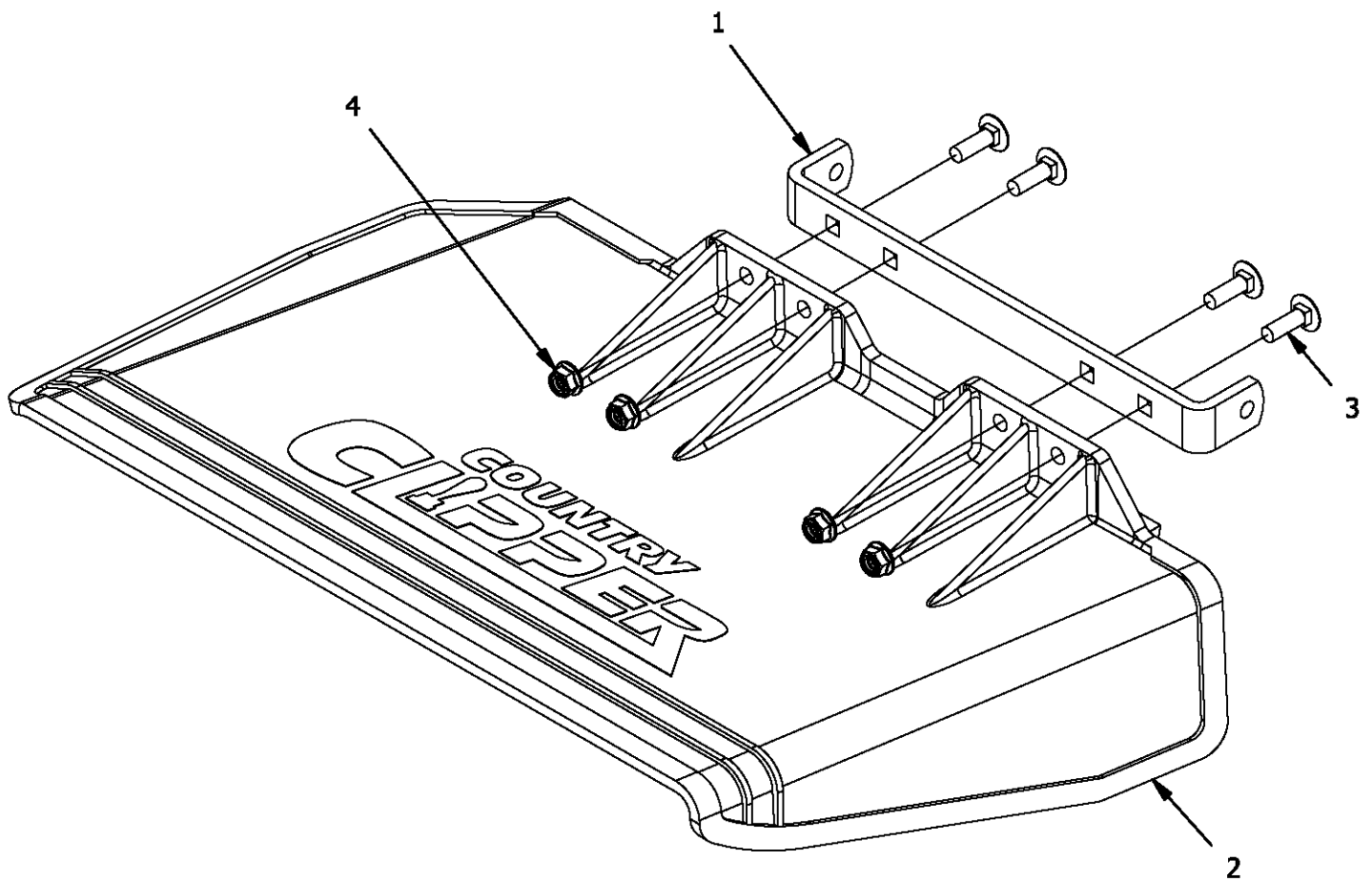

REF NO.	PART NO.	QTY.	DESCRIPTION
1	643-110P	1	CHUTE HINGE
2	H-2723	1	CHUTE, DISCHARGE, SMALL
3	F-2066	4	5/16-18 x 1" CARRIAGE BOLT,
4	F-2063	4	NUT, 5/16-18 NYLOC, FLANGED

# LIFT HANDLE ASSEMBLY & RELATED PARTS

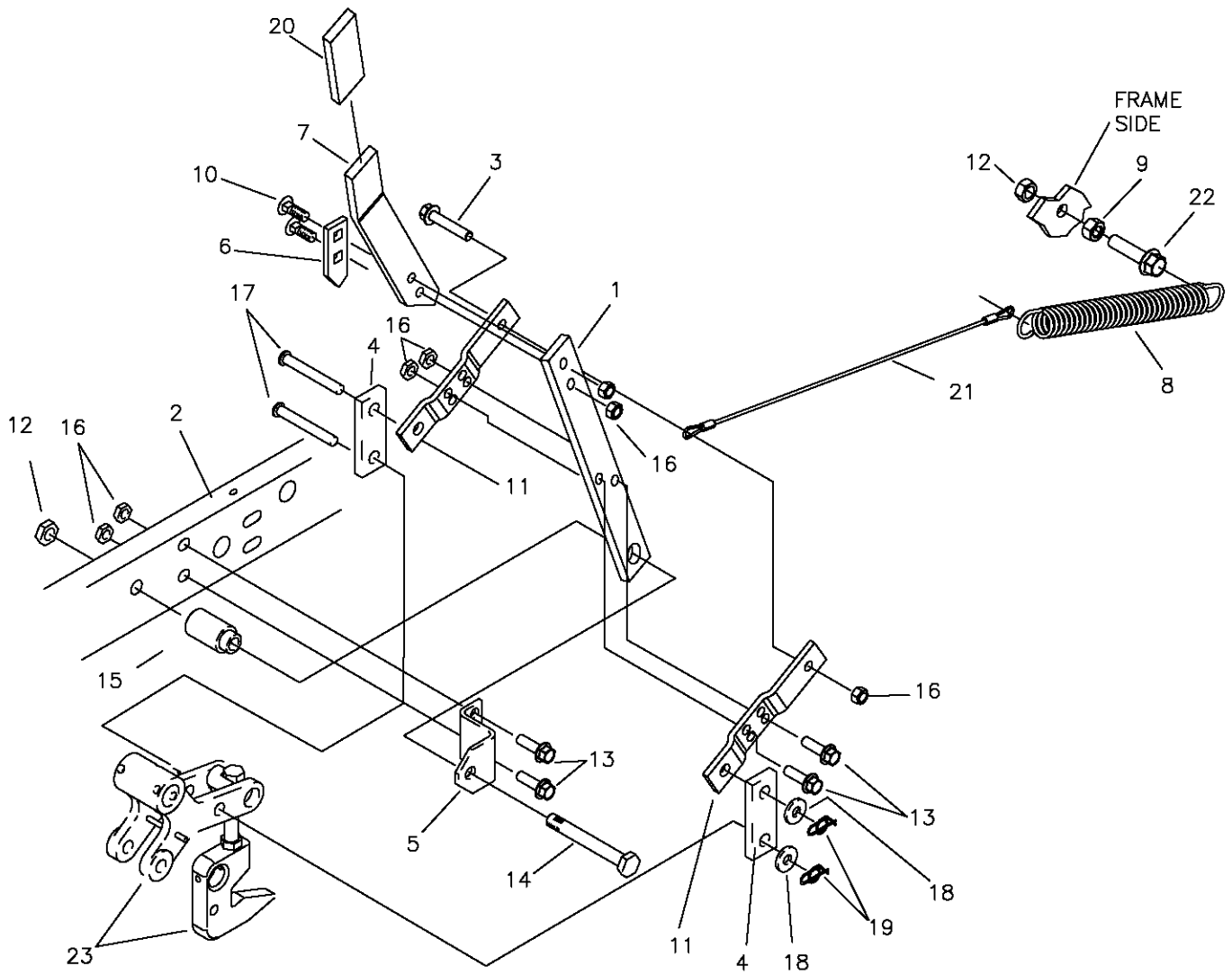

REF NO.	PART NO.	QTY.	DESCRIPTION	REF NO.	PART NO.	QTY.	DESCRIPTION
1	709-102P	1	LIFT HANDLE, LOWER	15	642-095P	1	HANDLE PIVOT PIN
2	659-022W	1	FRAME WELDMENT, LH.	16	F-1005-03	7	NUT, 3/8-16 LOCKNUT (STOVER)
3	F-2126	1	3/8-16 X 2" CAPSCREW	17	F-1889	2	CLEVIS PIN, 1/2 X 2 5/8"
4	642-061P	2	HANDLE LINK	18	F-1521	2	1/2" FLAT WASHER
5	642-041P	1	HANDLE PIVOT BRACKET	19	H-2239	2	RUE RING, 1/2"
6	642-127P	1	TOP PEG LATCH PLATE	20	H-2324	1	VINYL GRIP, 3/8 X 1 1/2"
7	659-355P	1	LIFY HANDLE, UPPER	21	H-2460	1	SPRING EXTENSION CABLE
8	H-1610	1	SPRING, 1 1/2" OD. X 8"	22	F-2128	1	FHCS 1/2-13 X 2" GR. 5
9	F-1462	1	NUT, 1/2-20 JAM	23	-----	-	SEE PAGE 9
10	F-1672	2	CARRIAGE BOLT, 3/8-16 X 1 1/4"				
11	642-060P	2	SPRING ANCHOR PLATE				
12	F-1005-05	2	NUT, 1/2-13 LOCKNUT				
13	F-2125	4	1/2-13 X 1 1/4" GR. 5				
14	F-1439	1	1/2-13 X 3" GR. 5				

# LIFT ASSEMBLY & RELATED PARTS

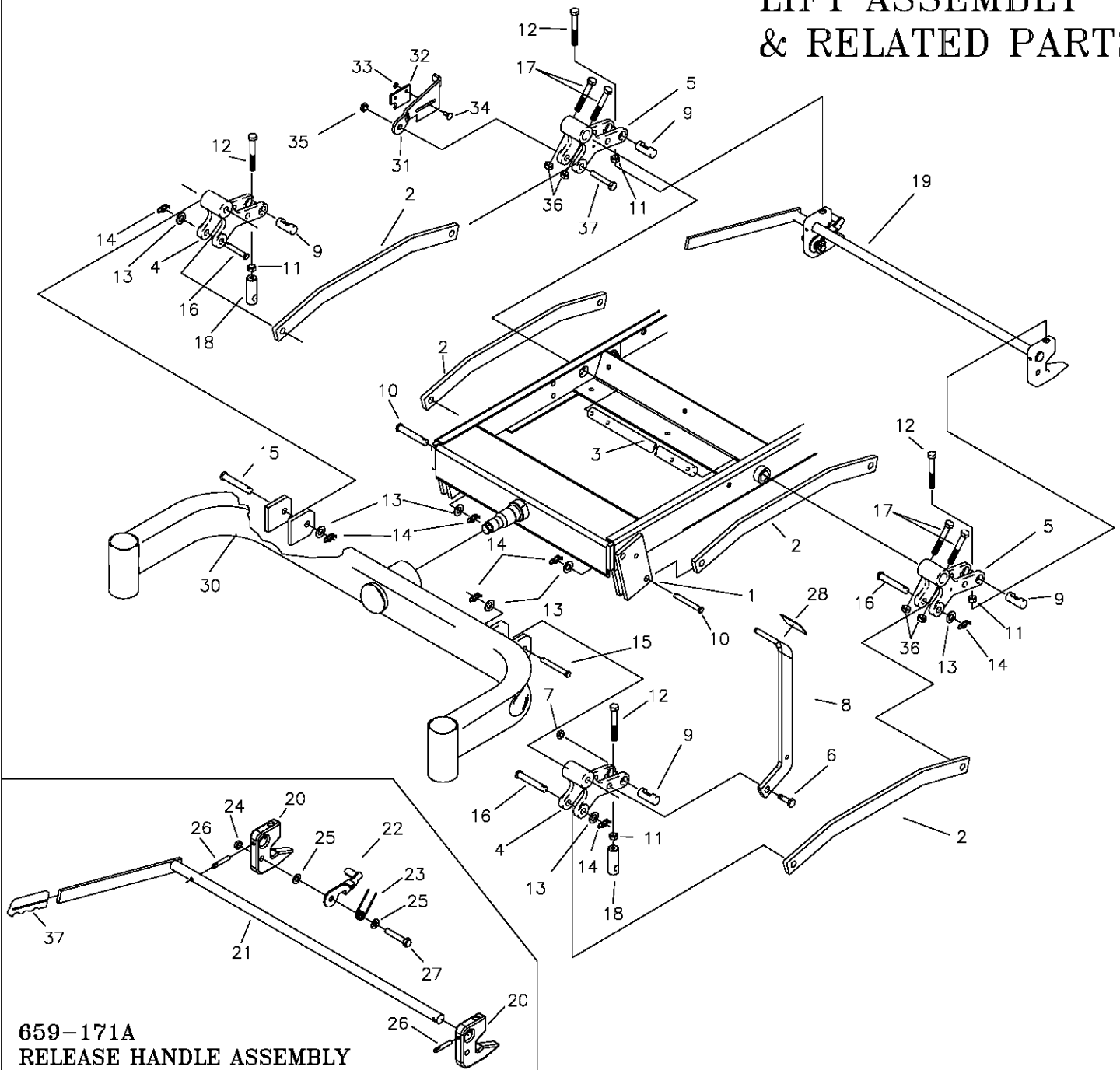

**659-171A  
RELEASE HANDLE ASSEMBLY**

REF NO.	PART NO.	QTY.	DESCRIPTION	REF NO.	PART NO.	QTY.	DESCRIPTION
1	642-063P	4	DRAG BAR TAB	20	659-140P	2	DECK HOOK
2	659-299P	4	DRAG LINK BAR	21	659-148W	1	RELEASE HANDLE WELDMENT
3	620-051P	1	LIFT BAR	22	659-145P	1	HOOK KEEPER
4	642-081P	2	LIFT SLEEVE, FRONT	23	H-2547	1	SPRING, TORSION
5	642-193P	2	LIFT SLEEVE, REAR	24	F-1005-03	1	NUT, 3/8-16, STOVER
6	F-1879	1	5/16-18 X 1 1/4" GR.5	25	F-1009-03	2	WASHER, FLAT, 3/8"
7	F-1125	1	5/16-18 STOVER NUT	26	F-2187	2	PIN, GROOVED, "c", 1/4X1.50", HARDENED
8	659-056P	1	DECK LIFT PEDAL	27	F-1073	1	CAPSCREW, 3/8-16 X 2, GR. 5
9	642-177P	4	HANGER PIN	28	H-2401	1	TREAD PAD
10	F-1815	2	CLEVIS PIN, 1/2 X 1 1/2"	29	H-1926	1	1/4"x1" HANDLE GRIP
11	F-1489	4	NUT. 1/2" JAM	30	659-287W	1	FRONT AXLE WELDMENT
12	F-1936	4	1/2-13 X 3 1/2, 2" THREAD	31	663-089P	1	LATCH PLATE
13	F-1521	7	WASHER, 1/2 NARROW	32	659-170P	1	PLATE, CATCH
14	H-2239	7	RUE RING, 1/2"	33	F-1158	2	NUT, 1/4" STOVER
15	F-1890	2	CLEVIS PIN, 1/2 X 3 1/2"	34	F-1823	2	CARRIAGE BOLT, 1/4-20 X 3/4"
16	F-1898	3	CLEVIS PIN, 1/2 X 2 3/4"	35	F-1005-05	1	1/2" STOVER NUT
17	F-2039	4	5/16-24 x 2" HHCS	36	F-2041	4	5/16-24 JAM NUT
18	642-175P	2	ADJUSTABLE HANGER END	37	F-1828	1	1/2-13 x 3-1/2" CAPSCREW
19	659-171A	1	RELEASE HANDLE ASSEMBLY				

# TRANSMISSION IDLERS & RELATED PARTS

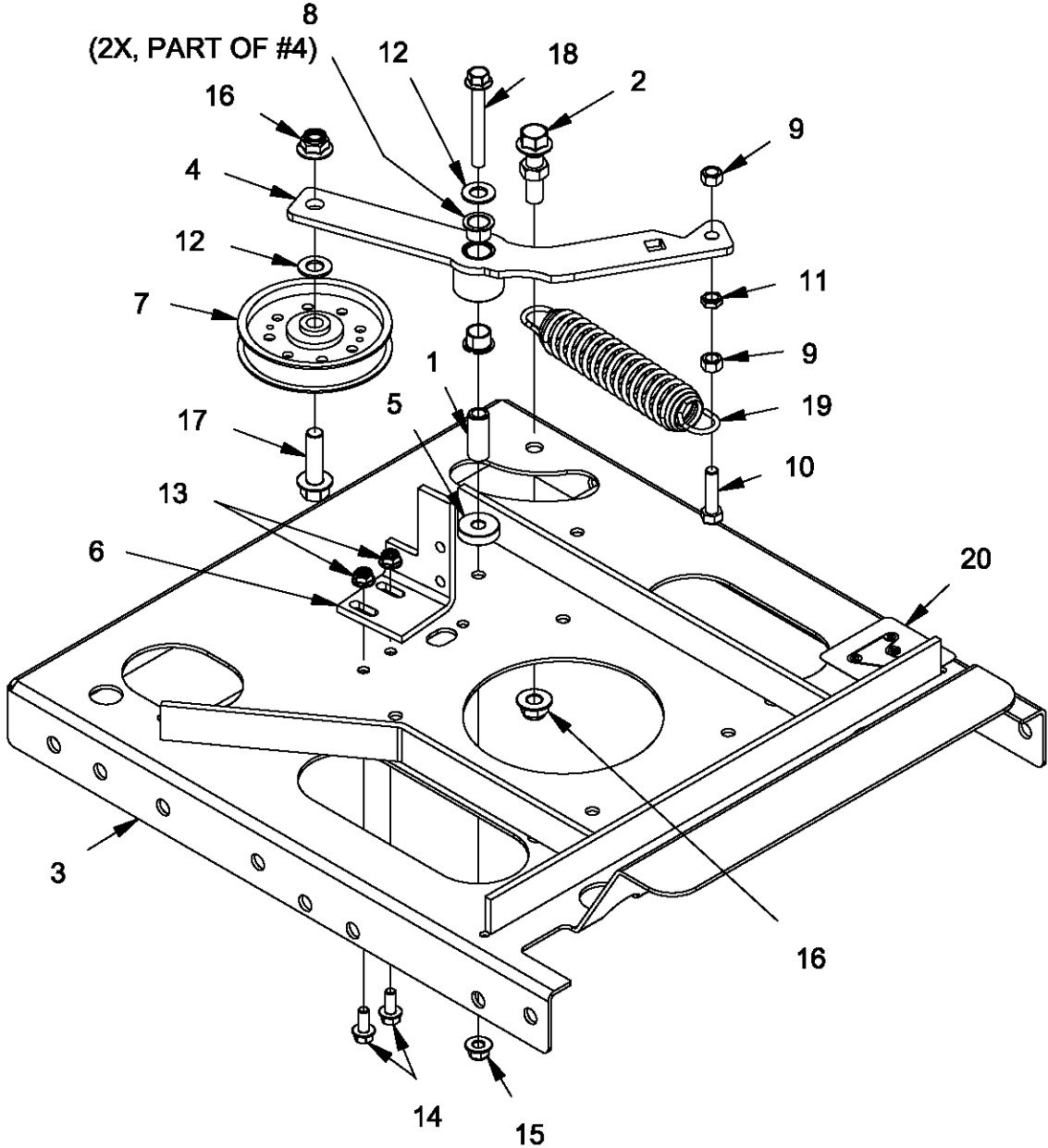

ITEM #	PART #	QTY	DESCRIPTION	ITEM #	PART #	QTY	DESCRIPTION
1	659-085P	1	Mounting Pin	11	F-1486	1	3/8-16 Jam Nut
2	700-146A	1	SPRING ANCHOR ASS'Y	12	F-1521	12	1/2" WASHER, CUSTOM
3	707-009W	1	WLDT, MOUNT, MOTOR	13	F-2063	57	Nut, 5/16-18 Nyloc, Flanged
4	707-012A	1	S/A, IDLER ARM	14	F-2120	32	FHCS, 5/16-18 x 0.75, YZ, GR5
5	707-022P	1	SPACER, 3/8X1-1/4, .500	15	F-2151	24	Nut, 3/8-16 Nyloc, Flanged
6	707-033P	1	CLUTCH STOP	16	F-2152	20	Nut, 1/2-13 Nyloc, Flanged
7	D-3922	1	4" Idler Pulley 1/2" Bore	17	F-2154	1	FHCS, 1/2-13 x 1-3/4", YZ, GR5
8	D-3730	2	FLANGED BUSHING	18	F-2180	1	FHCS, 3/8-16 x 3", YZ, GR5
9	F-1005-03	2	3/8-16 Stover Nut	19	H-2907	1	SPRING, 5.43 X 1-1/2, TAPERED ENDS
10	F-1015-27	1	3/8-16 x 1-1/2" Capscrew	20	P-12918	1	DECAL, HYDRO BELT ROUTING

# CASTER WHEEL ASSEMBLY

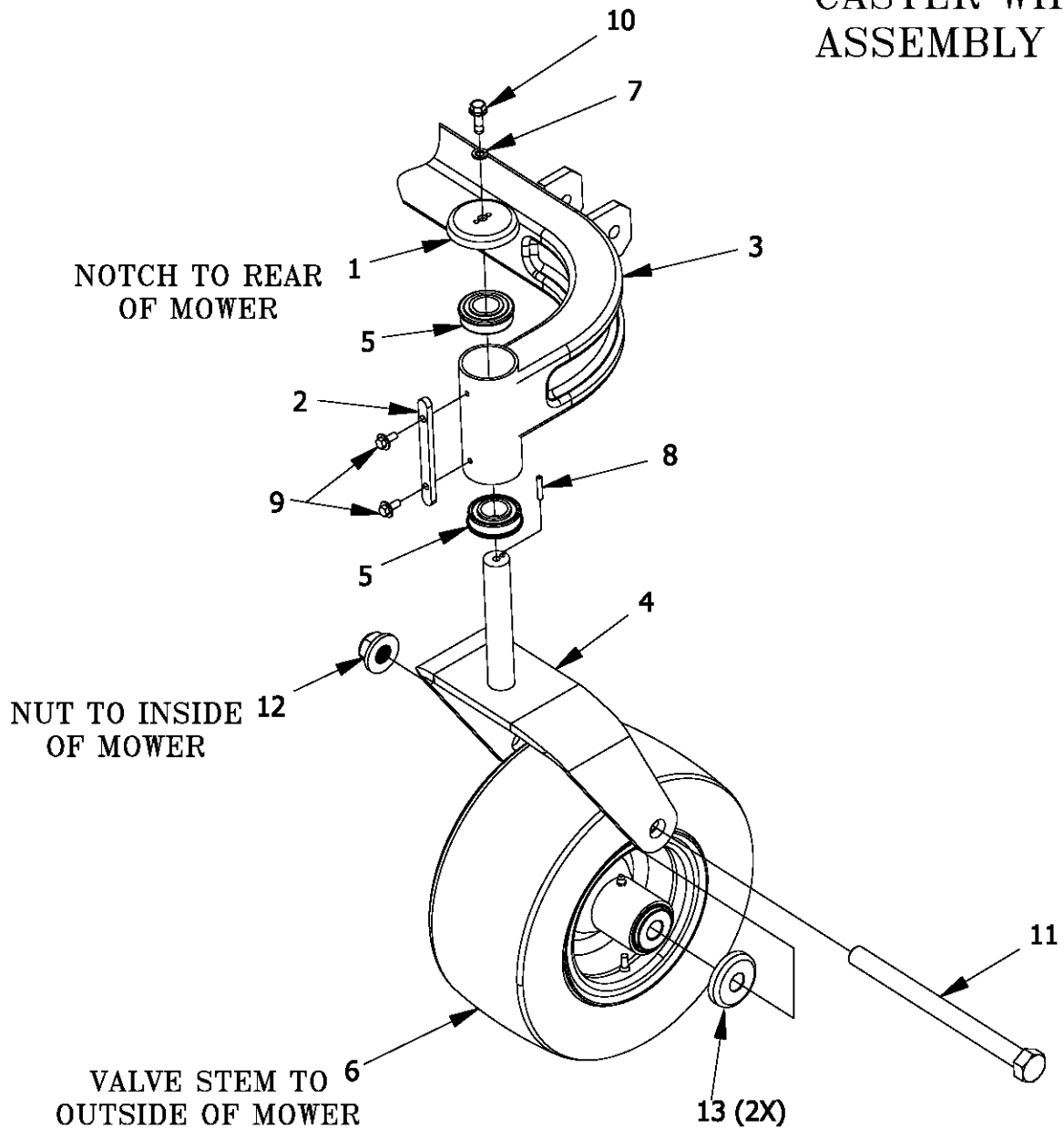

REF NO.	PART NO.	QTY.	DESCRIPTION	REF NO.	PART NO.	QTY.	DESCRIPTION
1	636-176P	2	Bearing Cap	8	F-1855	2	3/16 x 1" Roll Pin (Heavy Duty)
2	659-185P	2	Stop Tab	9	F-2030	4	1/4 x 5/8 Self Tapping Capscrew
3	659-287W	1	WLDT,AXLE,FRONT	10	F-2121	10	FHCS, 5/16-18x1.00, YZ, LOCK PATCH, GR5
4	663-217W	2	WLD'T, CASTER YOKE	11	F-2194	2	HHCS, 3/4-10 X 9-1/2", YZ, GR5
5	D-2008-02	4	Bearing SF-16-32	12	F-2195	2	NUT, FLANGE NYLOC, YZ
6	D-3936	2	TIRE ASS'Y, WHITE, SMOOTH, 13X6.5-6	13	663-221P	2	CAP FOR BEARINGS
7	F-1019-02	2	5/16" LockWasher				

# FRAME SIDES & RELATED PARTS

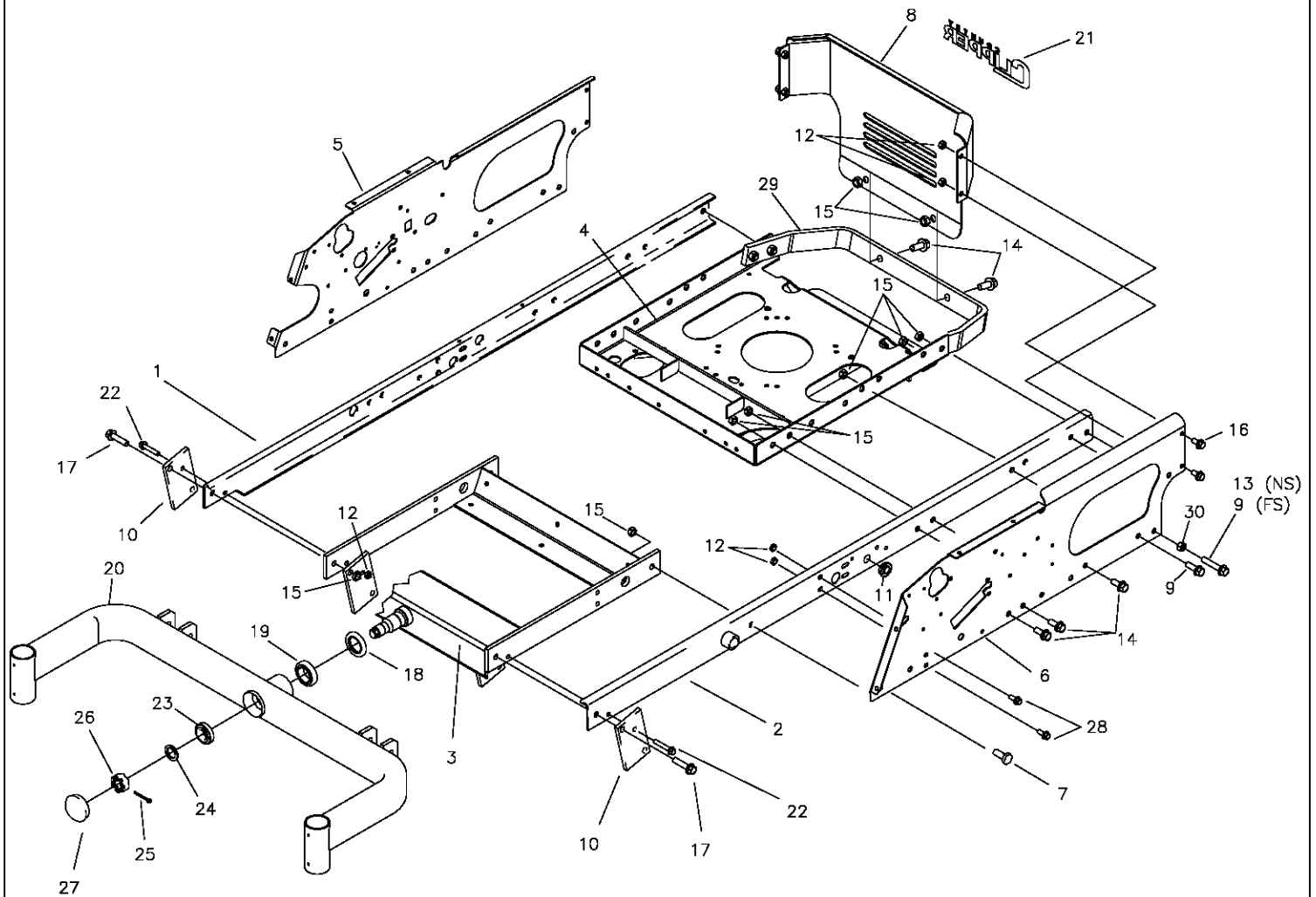

REF NO.	PART NO.	QTY.	DESCRIPTION	REF NO.	PART NO.	QTY.	DESCRIPTION
1	663-185W	1	FRAME SIDE RH.	16	F-2124	4	FHCS, 3/8-16 X 3/4" GR.5
2	663-187W	1	FRAME SIDE LH.	17	F-2128	2	FHCS, 1/2-13 X 2", GR.5
3	709-157W	1	AXLE MOUNTING WLDT.	18	H-2812	1	SEAL SHAFT
4	707-009W	1	MOTOR MOUNT WLDT.	19	D-3825	1	BEARING, TAPARED SET
5	707-091P	1	SIDE PANEL RH	20	659-287W	1	FRONT AXLE WELDMENT
6	707-092P	1	SIDE PANEL LH	21	P-12984	1	DECAL, NEW CC, LG, BLK
7	F-1386	2	1/2-13 X 1-1/4" GR.5	--	P-12986	1	DECAL, NEW CC, LG, CHROME
8	707-097A	1	ENGINE GUARD w/DECAL (BRIGGS)	22	F-2126	2	FHCS, 3/8-16 X 2" GR.5
--	707-098A	1	ENGINE GUARD w/DECAL	23	D-3826	1	BEARING, TAPARED SET
9	F-2140	3	FHCS, 1/2-13 X 1-1/2" GR.5	24	606-303P	1	1" WASHER
10	642-063P	2	DRAG BAR TAB	25	F-1728	1	3/16 X 2" COTTER PIN
11	H-2773	2	BEARING, FLG-SPHERICAL, IGUS	26	F-1724	1	1-14 SLOTTED NUT
12	F-2151	10	NUT, 3/8-16, NYLOC FLANGED	27	H-1924	1	GREASE CAP
13	F-1936	1	1/2-13 X 3-1/2" CAPSCREW	28	F-2125	4	FHCS, 3/8-16 X 1-1/4"
14	F-2127	15	FHCS, 1/2-13 X 1-1/4" GR.5	29	707-003P	1	GUARD, BUMPER
15	F-2152	17	NUT, 1/2-13, NYLOC FLANGED	30	F-1005-05	1	1/2-13 LOCK NUT

# FENDER ASSEMBLY

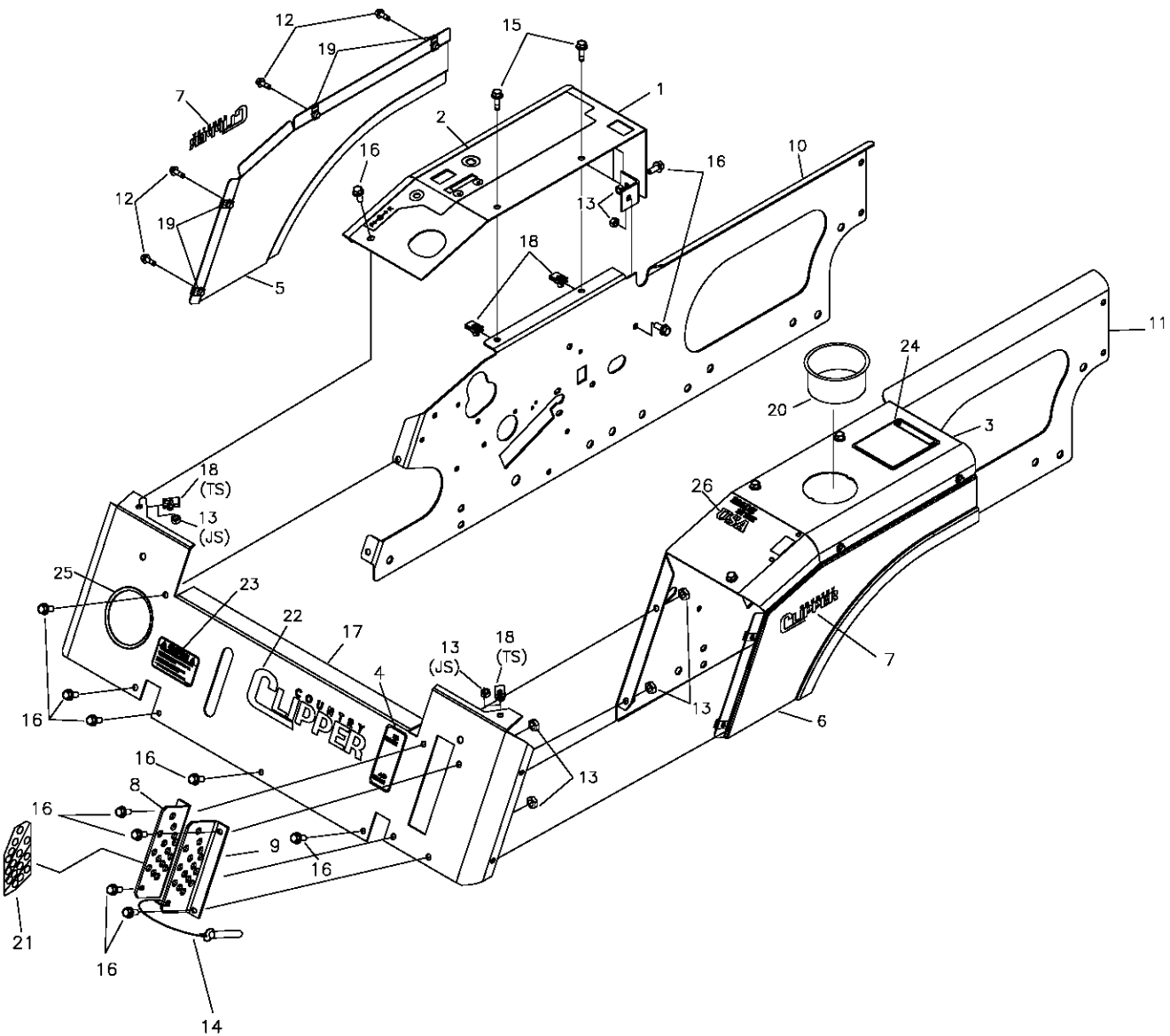

REF NO.	PART NO.	QTY.	DESCRIPTION	REF NO.	PART NO.	QTY.	DESCRIPTION
1	625-133A	1	FENDER CAP w/DECAL, RH	14	629-854A	1	LOCK PIN, DECK HEIGHT, ASS'Y
2	P-12925	1	DECAL, CONTROL PANEL	15	F-2121	4	FHCS, 5/16-18x1" GR.5 w/PATCH
3	625-134A	1	FENDER CAP w/DECAL, LH	16	F-2120	15	FHCS, 5/16-18 X 3/4" GR.5
4	P-11382	1	DECAL, PARK BRAKE	17	707-106A	1	FRONT PANEL w/DECALS (BRIGGS)
5	707-101A	1	FENDER SKIRT w/DECAL, RH (BRIGGS)	--	707-107A	1	FRONT PANEL w/DECALS (KAW, KOH)
--	707-103A	1	FENDER SKIRT w/DECAL, RH	18	F-1860	6	5/16-18 "U"-NUT
6	707-102A	1	FENDER SKIRT w/DECAL, LH, (BRIGGS)	19	F-1858	8	1/4-20 "U"-NUT
--	707-104A	1	FENDER SKIRT w/DECAL, LH	20	H-2228	1	CUP HOLDER
7	P-12985	2	DECAL, NEW CC, SM, BLK	21	P-12034	1	DECAL, "CUT HEIGHT"
--	P-12991	2	DECAL, NEW CC, SM, CHROME	22	P-12984	1	DECAL, NEW CC, LG, (BRIGGS)
8	647-097A	1	LATCH PLATE RH W/DECAL	--	P-12986	1	DECAL, NEW CC, LG, (KAW, KOH)
9	647-095P	1	LATCH PLATE LH	23	P-12557	1	DECAL, "CAUTION"
10	-----	1	SEE PAGE 12	24	P-11370	1	DECAL, WARNING
11	-----	1	SEE PAGE 12	25	H-1626	1	U CHANNEL TRIM
12	F-2119	8	FHCS, 1/4-20x3/4", GR.5 w/PATCH	26	P-13000	1	DECAL, "USA"
13	F-2063	13	NUT, 5/16-18, NYLOC FLANGED				



# SEAT, FOOTDECK & RELATED PARTS

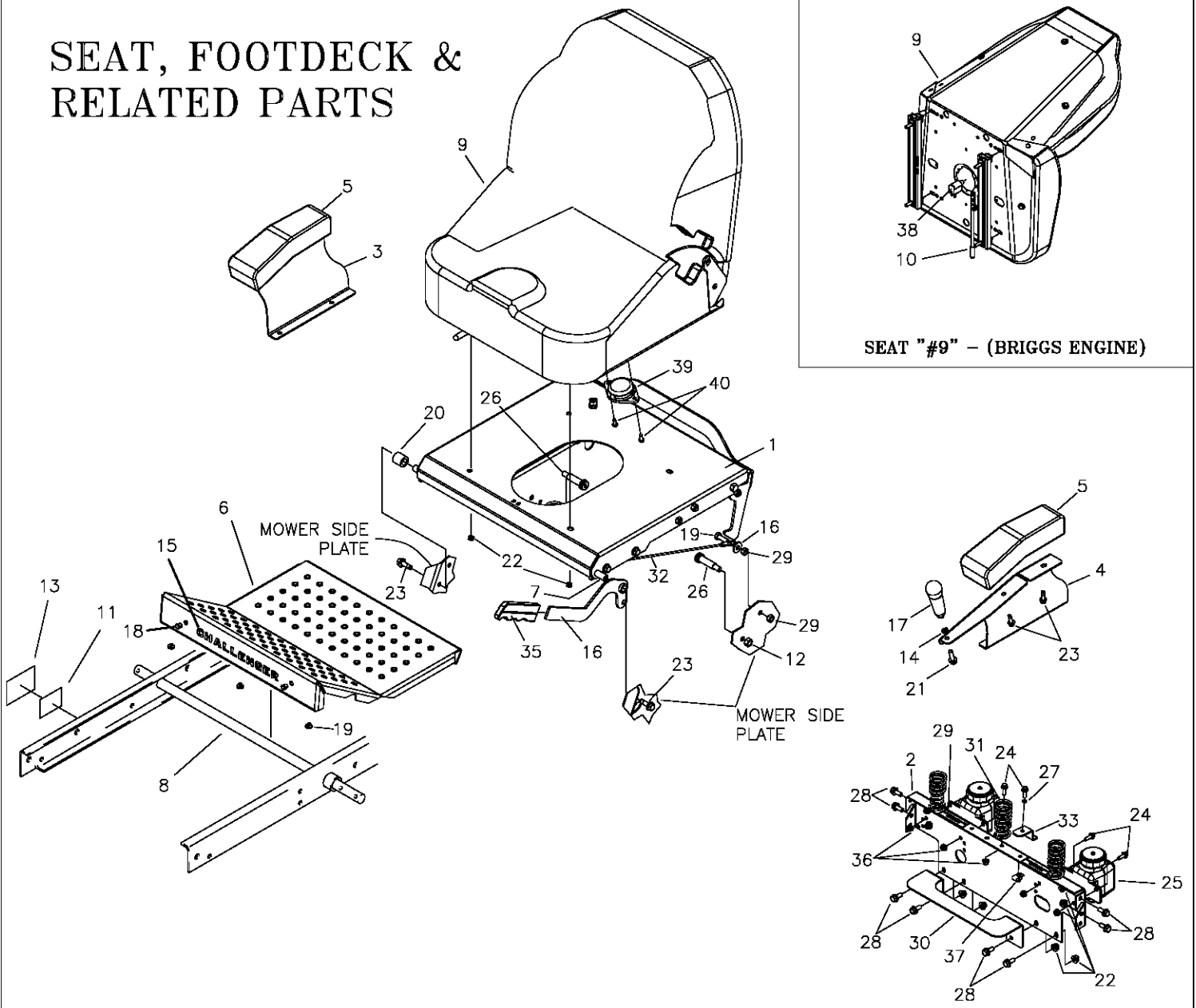

SEAT "#9" - (BRIGGS ENGINE)

REF NO.	PART NO.	QTY.	DESCRIPTION	REF NO.	PART NO.	QTY.	DESCRIPTION
1	707-005P	1	PLATE, SEAT	19	H-2461	3	RUBBER BUMPER
2	707-039P	1	PLT, REAR SEAT FILLER	20	707-046P	1	SPACER, SEAT PAN
3	707-047P	1	PLATE, ARM REST RH	21	F-2125	1	FHCS, 5/16-18x1-1/4" GR5
4	707-070P	1	PLATE, ARM REST LH (JOYSTICK)	22	F-2063	4	NUT, 5/16-18, NYLOC, FLANGED
-	707-048P	1	PLATE, ARM REST LH (TWINSTICK)	23	F-2121	6	FHCS 5/16-18x1" w/PATCH
5	H-2763	2	PAD, ARM REST	24	F-1015-02	1	1/4-20 X 5/8", GR.5
6	629-833A	1	FOOT DECK w/DECALS (BRIGGS)	25	D-3791	2	HYDRO OIL TANK
-	629-834A	1	FOOT DECK w/DECALS (KAW & KOH)	26	F-1783	2	1/2"x1-1/2" SHOULDER BOLT, SOCKET
7	707-043P	1	PIN, SEAT HINGE	27	F-1019-01	1	1/4" LOCK WASHER
8	620-051P	1	LIFT BAR	28	F-2120	8	FHCS, 5/16-18x3/4" GR5
9	H-2754	1	SEAT (KAWASAKI & KOHLER)	29	P-11052	2	HYDRO FLUID DECAL
--	H-2604	1	SEAT (BRIGGS)	30	707-066P	1	SHELF, REAR, FUEL TANK
--	H-2910	1	COVER FOR SEAT H-2754	31	H-1920	3	SPRING, ASSIST
10	H-2760	1	TRACK KIT	32	H-2460	1	CABLE
11	P-12940	1	SERIAL TAG	33	659-137P	1	BATTERY HOLD DOWN
12	F-1005-03	2	3/8-16 LOCK NUT	34	F-1538	3	1/4-20x3/4" CAPSCREW
13	P-12473	1	SERIAL TAG LAMINATION DECAL	35	H-1926	1	HANDLE, GRIP
14	F-1486	1	3/8-16 JAM NUT	36	F-1005-01	1	1/4-20 STOVER NUT
15	P-12942	1	DECAL, CHALLENGER (BRIGGS)	37	F-1858	1	1/4-20 "U" NUT
--	P-12981	1	DECAL, CHALLENGER (KAW & KOH)	38	E-6580	1	PLUNGER, SEAT SWITCH E-6374
16	707-042W	1	BRAKE HANDLE	39	E-6374	1	SEAT SWITCH
17	H-2764	1	HANDLE, JOYSTICK	40	F-1785	2	HEX SCREW, 14 X 3/4"
18	H-1280	2	CAP PLUG, PLASTIC				

# SEAT, FOOTDECK & RELATED PARTS (CON'T)

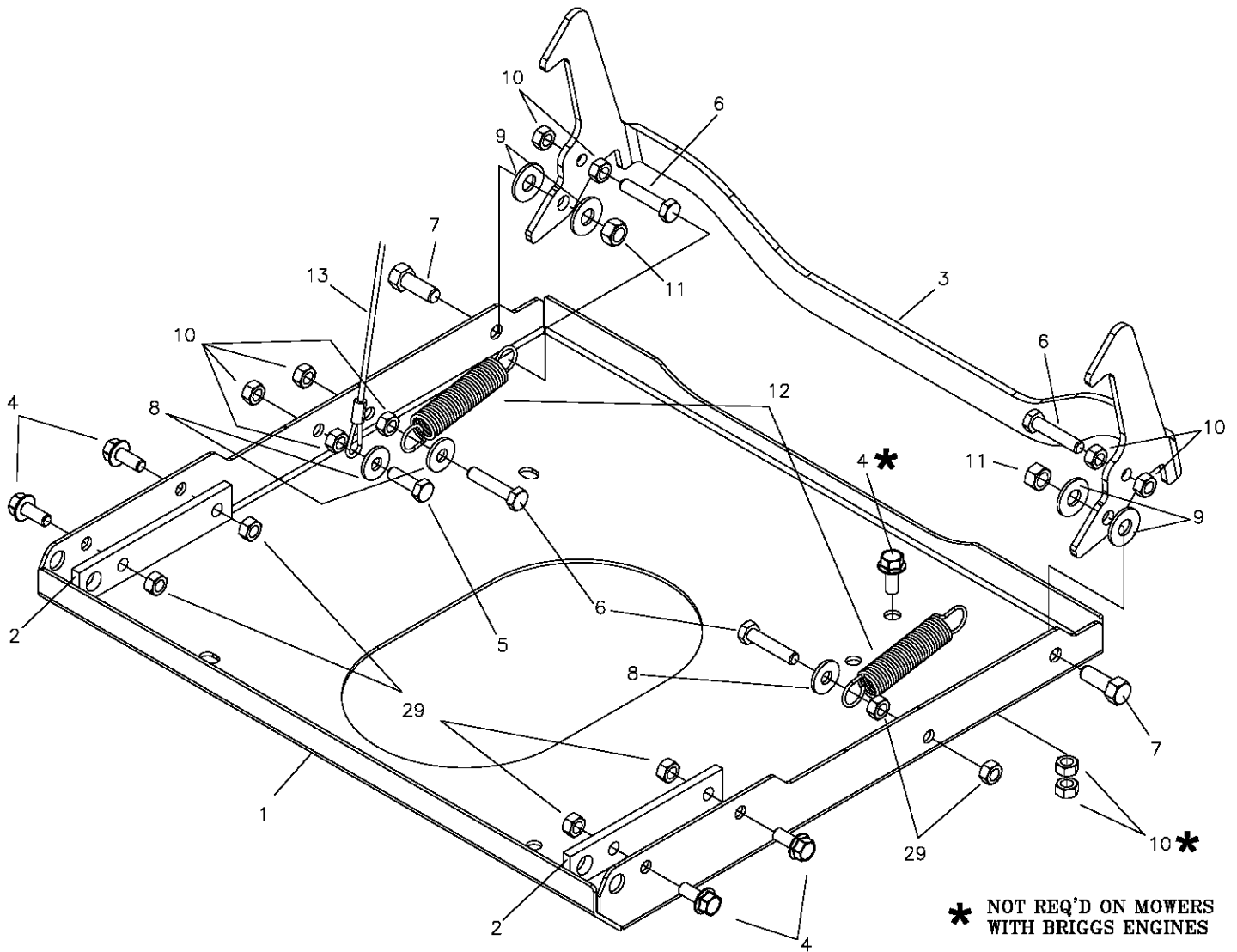

\* NOT REQ'D ON MOWERS  
WITH BRIGGS ENGINES

## UNDERSIDE OF SEAT MOUNTING BASE "#1" - LATCH PARTS

REF NO.	PART NO.	QTY.	DESCRIPTION	REF NO.	PART NO.	QTY.	DESCRIPTION
1	707-005P	1	PLATE, SEAT	8	F-1009-02	3	5/16 FLAT WASHER
2	707-045P	2	BAR, REINFORCEMENT, SEAT	9	F-1521	4	1/2" WASHER, SPECIAL
3	707-080P	1	LATCH SEAT	10	F-1125	16	5/16-18 NUT, STOVER
4	F-2120	5	FHCS, 5/16-18x3/4" GR5	11	F-1005-03	2	3/8" FLAT WASHER
5	F-1015-15	1	5/16-18 x 1" CAPSCREW	12	H-1635	2	3/4 x 4" EXTENSION SPRING
6	F-1015-27	4	5/16-18 x 1-1/2", CAPSCREW	13	H-2460	1	CABLE, SEAT
7	F-1394	2	3/8-16 x 1" CAPSCREW				

# FRONT STEP ASSEMBLY

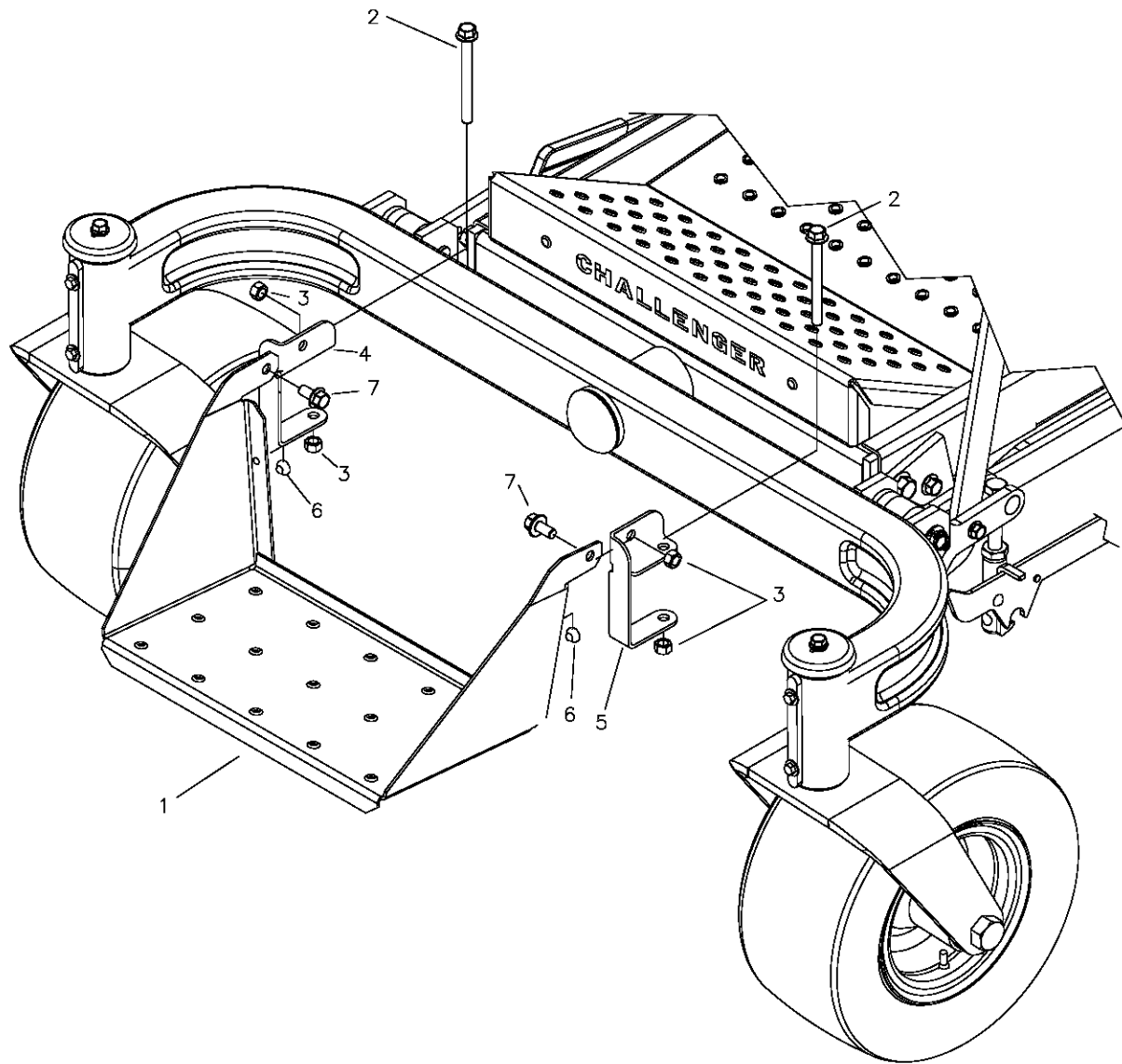

REF NO.	PART NO.	QTY.	DESCRIPTION
1	663-134P	1	FRONT STEP
2	F-2142	2	FHCS, 3/8-16 X 4" GR.5
3	F-2151	4	NUT, 3/8-16, NYLOC FLANGED
4	659-241P	1	BRACKET, STEP MOUNT, RH
5	659-242P	1	BRACKET, STEP MOUNT, LH
6	H-2461	2	RUBBER BUMPER BUTTON
7	F-2124	2	FHCS, 3/8-16 X 3/4" GR.5

# FUEL TANK ASSEMBLY H-2944

(INCLUDES ALL PARTS EXCEPT #6-10)

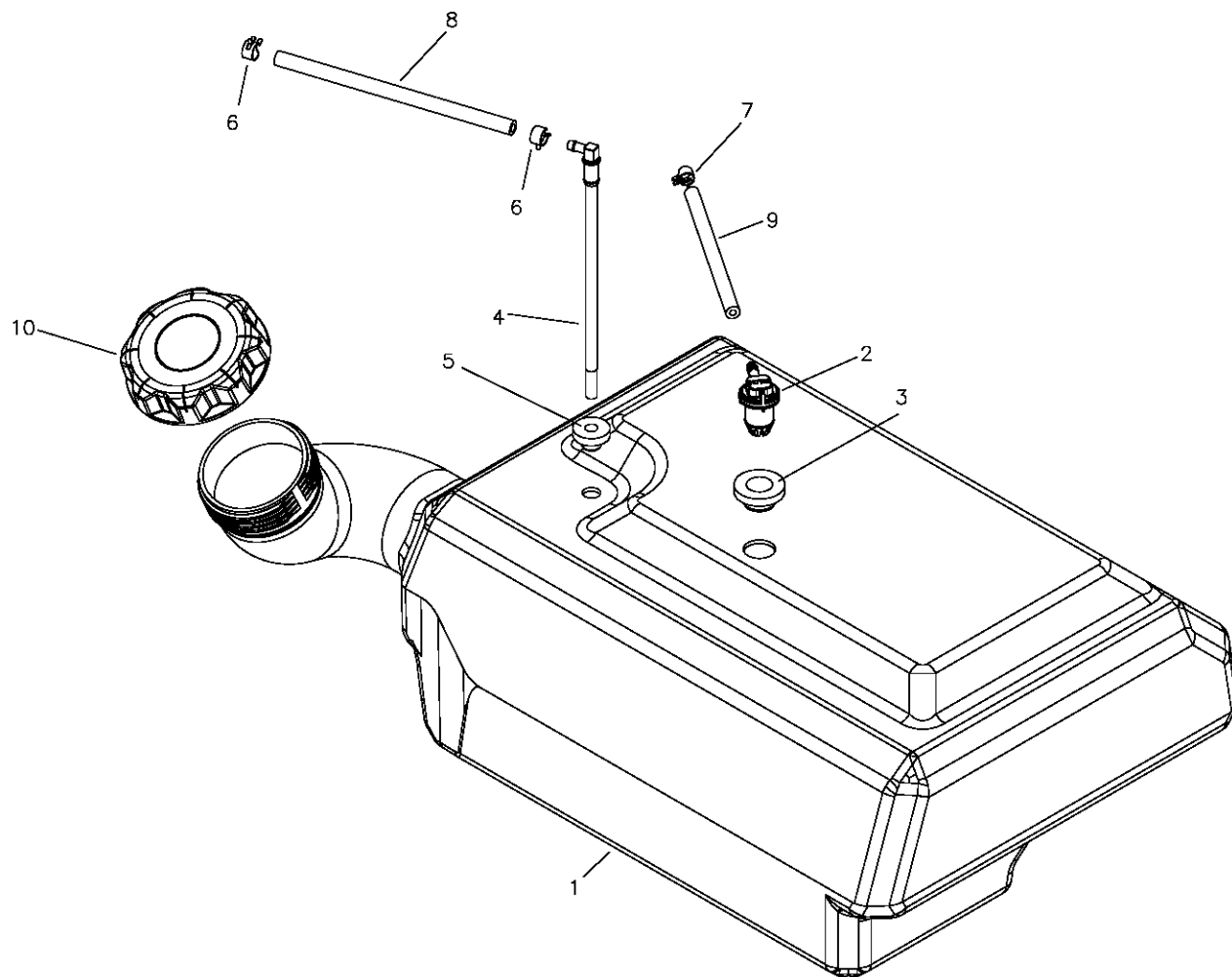

REF NO.	PART NO.	QTY.	DESCRIPTION
1	-----	-	7 GALLON TANK, VENTED
2	H-2678	1	REMOTE VENT
3	H-2679	1	REMOTE VENT GROMMET
4	H-2742	1	PICK UP TUBE
5	H-2741	1	GROMMET, PICK UP TUBE
6	H-1687	2	HOSE CLAMP, 1/2"
7	H-2698	2	VENT LINE CLAMP
8	H-1648	4.0ft	FUEL LINE
9	H-2697	4.0ft	VENT LINE
10	H-2743	1	GAS CAP, RATCHET

# JOYSTICK STEERING CONTROL AND RELATED PARTS

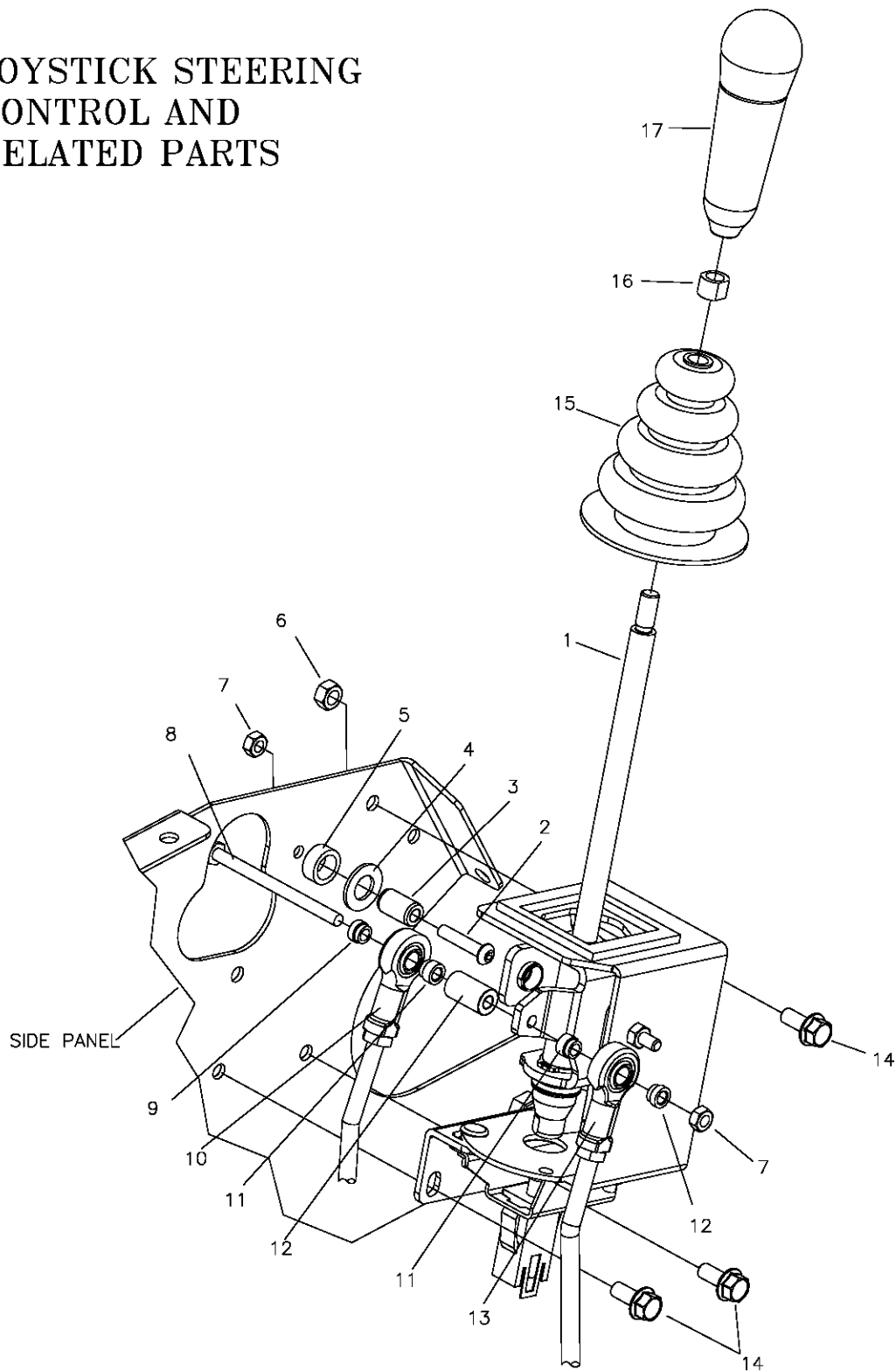

REF NO.	PART NO.	QTY.	DESCRIPTION	REF NO.	PART NO.	QTY.	DESCRIPTION
1	625-170A	1	JOYSTICK ASSEMBLY	10	707-082P	1	LINKAGE, INNER, JOYSTICK
2	F-2103	1	BUTTON SHCS, 1/4-20x1"	11	625-107P	1	BUSHING, .375 ROD END
3	625-119P	1	PIN, PIVOT, JS, LONG	12	625-100P	1	TUBE, PIVOT, JOYSTICK
4	F-1521	1	1/2" WASHER	13	707-083P	1	OUTER, LINKAGE, JOYSTICK
5	625-126P	1	SPACER, JOYSTICK PANEL	14	F-2120	3	FHCS, 5/16-18 x 3/4" GR5
6	F-2063	3	NUT, 5/16-18, NYLOC FLANGED	15	H-1991	1	BOOT
7	F-2132	2	NUT, 1/4-20, NYLOC FLANGED	16	H-2765	1	NUT, JOYSTICK
8	F-1020-01	1	1/4-20 x 3-1/2" CAPSCREW	17	H-2764	1	HANDLE, JOYSTICK
9	625-116P	1	BUSHING, .375 ROD END, SHORT				

# JOYSTICK ASSEMBLY 625-170A

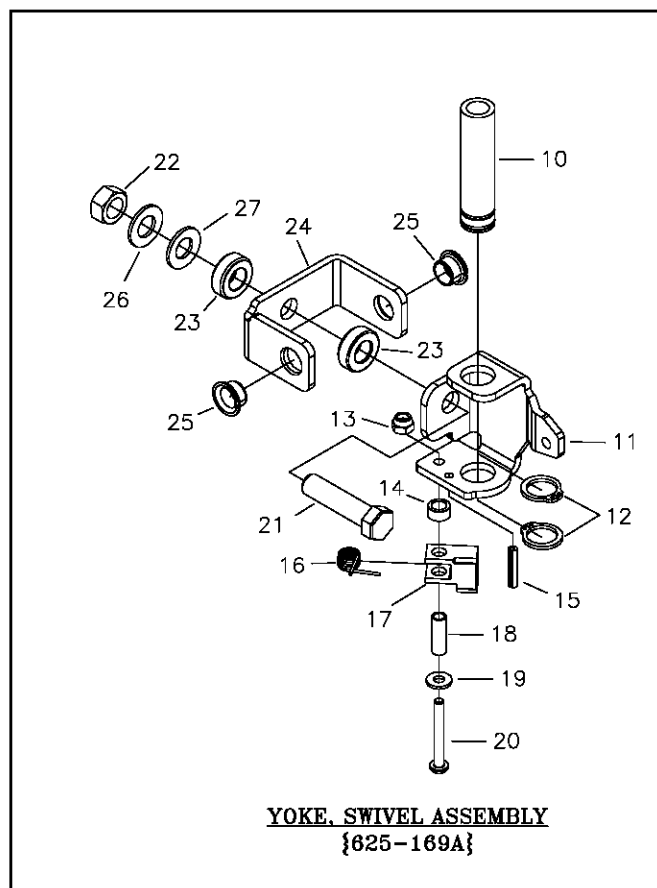
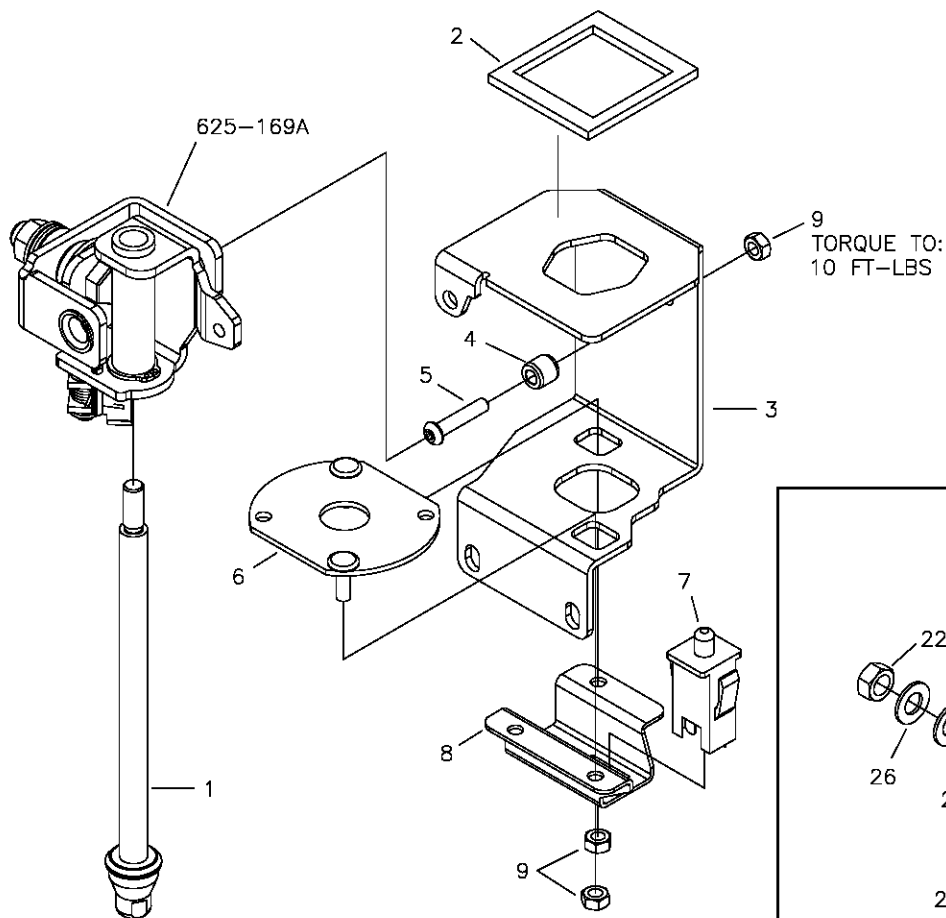

ITEM	PART #	QTY.	DESCRIPTION	ITEM	PART #	QTY.	DESCRIPTION
1	625-130A	1	ROD ASSEMBLY, SHORT	15	F-1503	1	3/16 x 1" SPIRAL PIN
2	H-1947	1	GASKET, FOAM, JOYSTICK	16	H-2710	1	SPRING, DETENT, JOYSTICK
3	625-095P	1	HOUSING, JOYSTICK	17	625-103P	1	TAB, CAM DETENT
4	625-106P	1	PIN, PIVOT, JOYSTICK	18	625-124P	1	TUBE-SPACER, DETENT CAM
5	F-2103	1	BUTTON SHCS, 1/4-20 x 1", CZ	19	F-2136	1	WASHER, FLAT, #12 PLAIN
6	625-127W	1	NEUTRAL PLATE, WLDT	20	F-2135	1	SCR, PANHD, PHLPS, #12-24x1-3/4"
7	E-6474	1	SWITCH, SNAP MOUNT	21	F-1293	1	1/2-13 x 2" CAPSCREW
8	659-285P	1	MOUNT, SWITCH	22	F-1005-05	1	1/2-13 STOVER NUT
9	F-1005-01	3	1/4-20 LOCK NUT	23	D-3931	2	THRUST BEARING
10	625-099P	1	TUBE, GUIDE, CONTROL ROD	24	625-097P	1	PIVOT, JOYSTICK (PART OF 625-128A)
11	625-096P	1	YOKE, SWIVEL, JOYSTICK	25	D-3784	2	BUSHING, FLANGED (PART OF 625-128A)
12	H-2705	2	RING, DETENT, .75 EXT.	26	F-1521	1	1/2" WASHER, CUSTOM
13	F-2137	1	NUT, #12-24, NYLOCK	27	H-2704	1	SPRING, BELLEVILLE, .50x1x.073
14	625-125P	1	SPACER, CAM DETENT				

# JOYSTICK STEERING CONTROL & RELATED PARTS

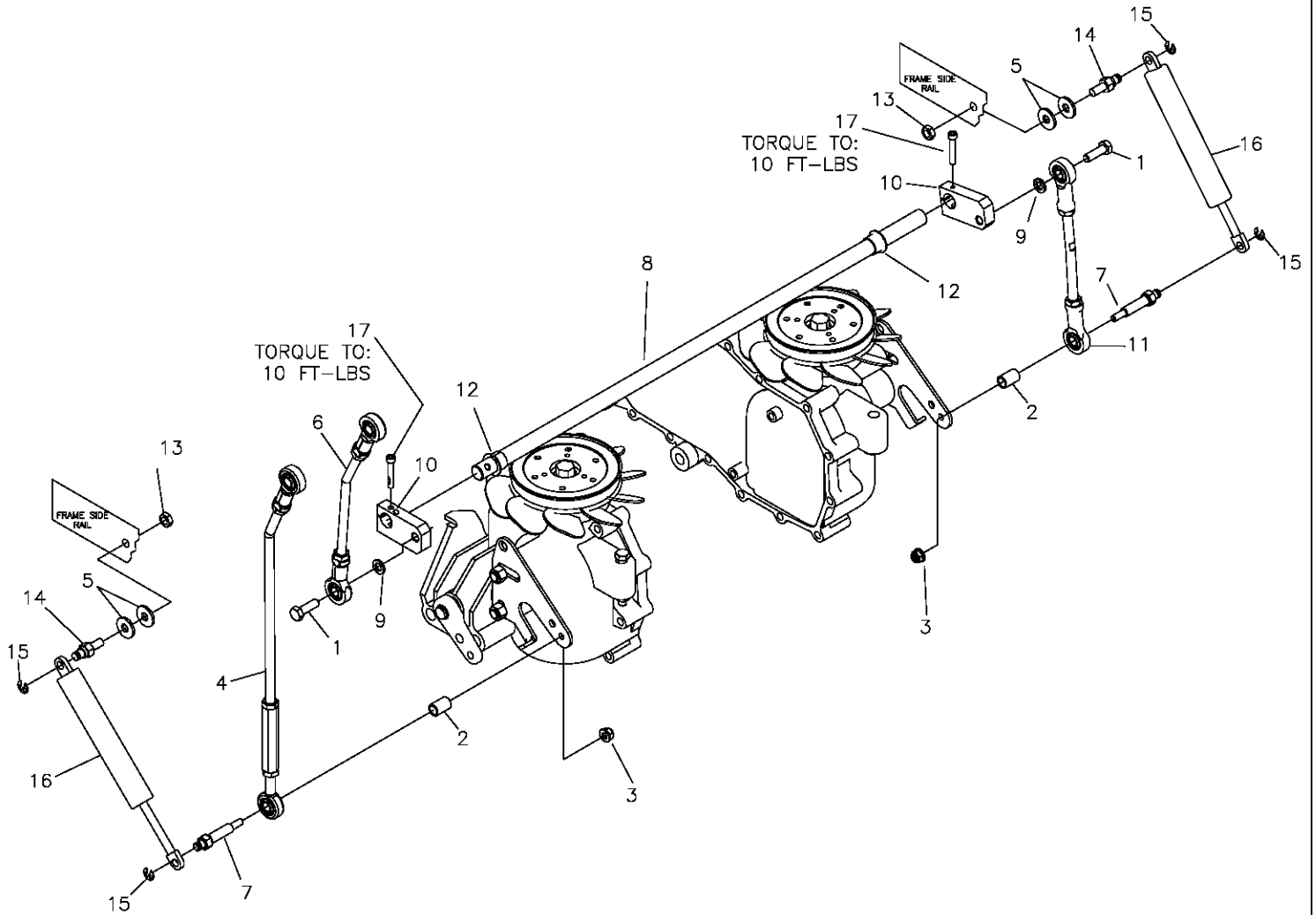

ITEM #	PART #	QTY	DESCRIPTION
1	F-2141	2	FHCS, 3/8-16 X 1", YZ, GR5
2	707-073P	2	STAND-OFF, LINKAGE MOUNT
3	F-2132	2	NUT, 1/4-20 NYLOC, FLANGED
4	707-083P	1	OUTER LINKAGE, JS
5	F-1009-02	4	5/16" FLAT WASHER
6	707-082P	1	INNER LINKAGE, JS
7	707-072P	2	STUD, LINKAGE MOUNT
8	700-150P	1	ROD, SHIFT CROSS
9	F-1019-03	2	3/8" LOCKWASHER
10	700-151P	2	SWIVEL ARM
11	H-2757	1	LINKAGE, JS
12	D-3730	2	BUSHING
13	F-2063	2	NUT, 5/16-16, NYLOC FLANGED
14	638-028P	2	DAMPER BOLT, 5/16-18 x 3/4
15	F-1610	4	E-RING FOR 1/4" SHAFT
16	H-2467	2	DUAL ACTION DAMPER
17	F-2231	2	SHCS, 12-24X1-1/4, YZ, LOCK PATCH

# PARKING BRAKE ASSEMBLY & RELATED PARTS

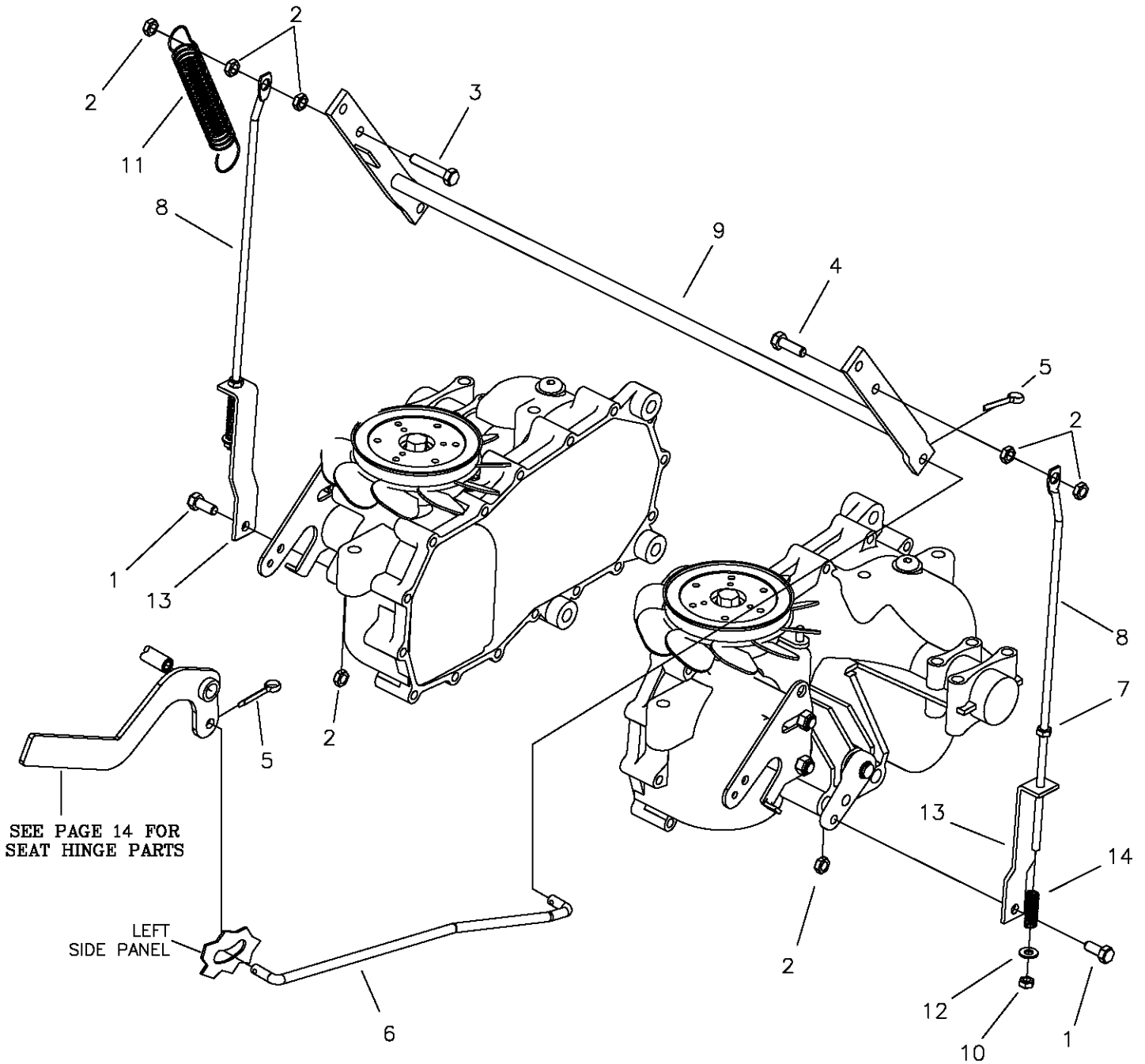

ITEM #	PART #	QTY	DESCRIPTION
1	F-2120	4	FHCS, 5/16-18 X 3/4", YZ, GR5
2	F-2063	6	NUT, 5/16-18, NYLOC FLANGED
3	F-1693	1	5/16-18 X 1-1/2" H.H.C.S.
4	F-1015-15	1	5/16-18 X 1" H.H.C.S
5	F-1491	2	1" COTTER PIN
6	707-044P	1	LINK, PARK BRAKE
7	F-2132	2	NUT, 1/4-20, NYLOC FLANGED
8	H-2452	2	BRAKE LINK BAR, BENT
9	659-206W	1	BRAKE ROD WELDMENT
10	F-1748	2	1/4" NYLOC LOCK NUT
11	H-1635	1	EXTENSION SPRING 3/4 X 4"
12	F-1009-01	2	1/4" FLAT WASHER
13	659-159P	2	LOWER BRAKE LINK
14	H-1637	2	COMPRESSION SPRING



# MOTOR & TRANSMISSION ASS'Y & RELATED PARTS FOR 24HP KAWASAKI

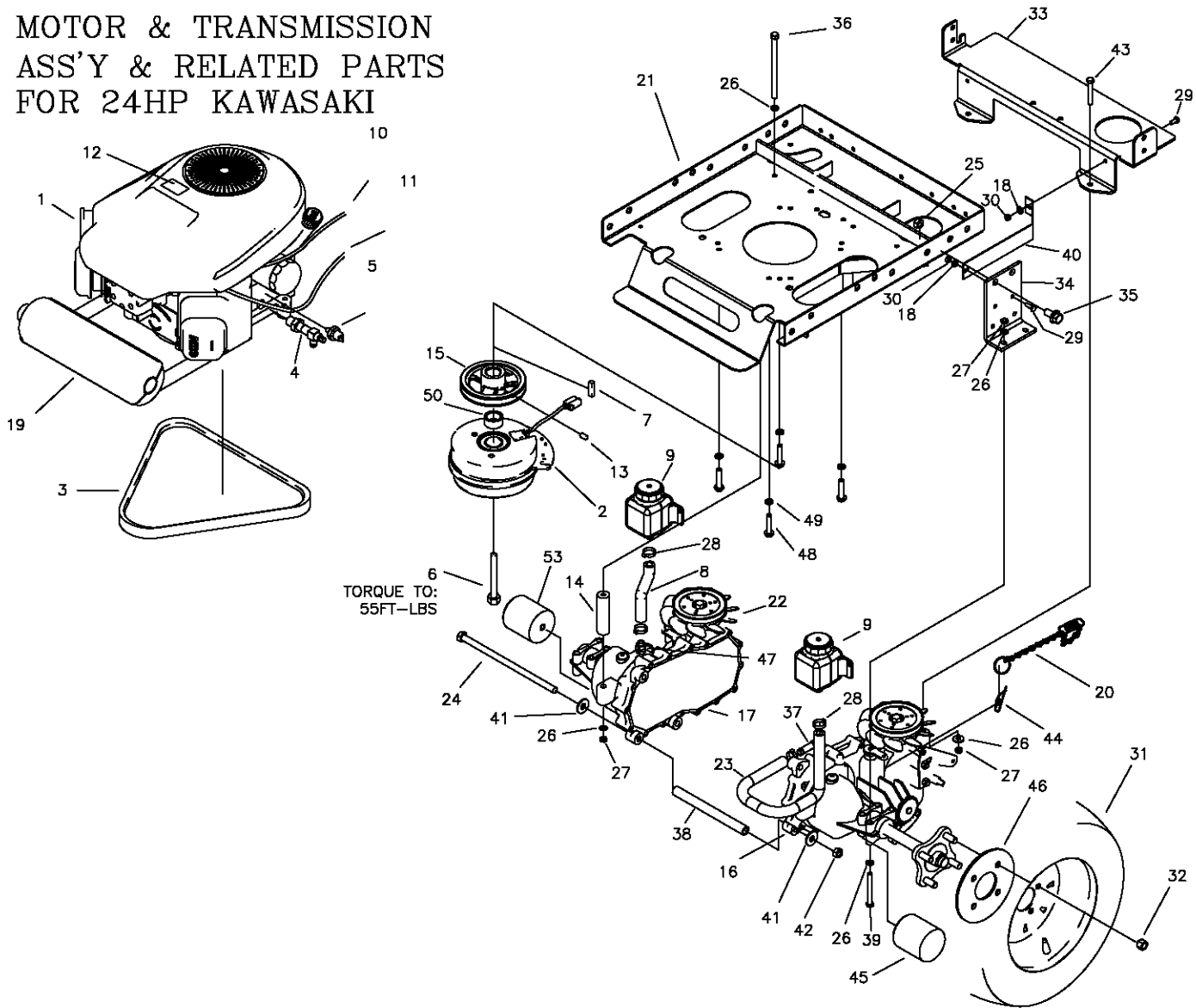

ITEM #	PART #	QTY	DESCRIPTION	ITEM #	PART #	QTY	DESCRIPTION
1	M-5395	1	ENGINE, KAW 24HP, FS730V TWIN	27	F-2063	8	NUT, 5/16-18, NYLOC FLANGED
2	E-6532	1	CLUTCH-BRAKE, CMS 200ft/lb	28	H-2535	4	HOSE CLAMP
3	D-3905	1	V-BELT, KEVLAR CORD, A-69	29	F-2162	4	FHCS, 1/4-20 X 3/4", YZ GR5
4	H-2590	1	OIL DRAIN VALVE	30	F-2132	4	NUT, 1/4-20, NYLOC FLANGED
5	E-6307	1	OIL PRESSURE SWITCH	31	D-3881	2	TIRE, 22x11-10, TURF
6	F-2113	1	7/16-20x2-1/2" CAPSCREW, GR8	32	F-1499	8	LUG NUT, 1/2 X 20
7	621-113P	1	KEY, 1/4 SQ. X 1-1/4"	33	707-036P	1	BRACE, TRANSMISSION
8	H-2549	1	HOSE 5" LONG	34	707-086P	1	BRACKET, HYDRO MOUNT, R
9	D-3791	2	SMALL HYDRO TANK	--	707-087P	1	BRACKET, HYDRO MOUNT, L
10	H-2287	1	CHOKE CABLE	35	F-2127	4	FHCS, 1/2-13 X 1-1/4" GR5
11	H-2610	1	THROTTLE CABLE	36	F-2145	2	5/16-18 X 6" BOLT GR8
12	P-10077-11	1	DECAL, "CLEAN"	37	H-2762	1	VENT TUBE ADAPTER
13	F-1228	1	SETSCREW, 1/4" X 1/4"	38	659-173P	1	HYDRO BRACE
14	659-121P	2	REAR HYDRO BRACE	39	F-2178	4	FHCS, 5/16-18 X 3", YZ GR5
15	707-085P	1	MOTOR PULLEY	40	707-061P	2	FAN SHROUD
16	D-3882-01	1	TRANSAXLE, RH, ZT-3400	41	F-1009-03	2	3/8" FLAT WASHER
17	D-3882-02	1	TRANSAXLE, LH, ZT-3400	42	F-2151	1	NUT, 3/8-16, NYLOC FLANGED
18	F-1009-01	4	1/4" FLAT WASHER	43	F-2177	2	FHCS, 5/16-18 x 2-1/2", YZ GR5
19	H-2759	1	MUFFLER, KAWASAKI	44	F-1492	2	5/16-3/8 RUE RING
20	707-074P	2	FREEWHEEL CHAIN W/SPRING	45	H-2567	2	TRANSAXLE OIL FILTER
21	707-009W	1	MOTOR MOUNT	46	659-092P	2	WHEEL BACKING PLATE
22	H-2539	2	FAN BLADE REPLACEMENT	47	H-2517	1	VENT TUBE ADAPTER
23	H-2761	1	HOSE, 1/2" x 19"	48	F-2125	4	FHCS, 3/8-16 X 1-1/2", YZ, GR5
24	F-2007	1	3/8-16 X 12-1/2" HEX BOLT	49	F-1019-03	4	3/8" LOCK WASHER
25	F-2152	4	NUT, 1/2-13, NYLOC FLANGED	50	F-2043	1	SPACER
26	F-1009-02	14	5/16" FLAT WASHER				

**MOTOR & TRANSMISSION  
ASS'Y & RELATED PARTS  
FOR 25HP KOHLER**

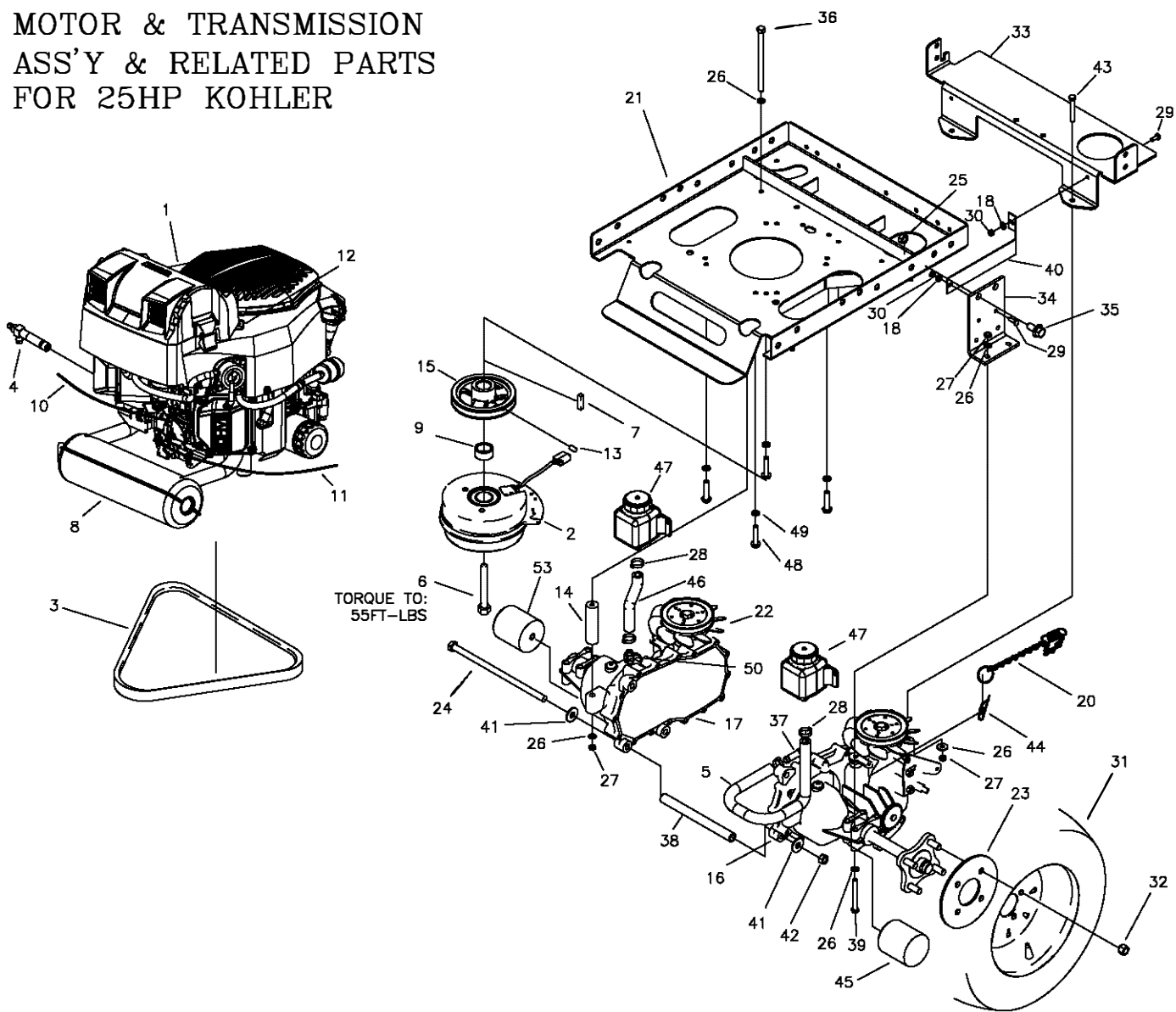

ITEM #	PART #	QTY	DESCRIPTION	ITEM #	PART #	QTY	DESCRIPTION
1	M-5404	1	ENGINE, KOHLER, 25HP ZT740	27	F-2063	10	NUT, 5/16-18, NYLOC FLANGED
2	E-6532	1	CLUTCH-BRAKE, CMS 200ft/lb	28	H-2535	4	HOSE CLAMP
3	D-3905	1	V-BELT, KEVLAR CORD, A-69	29	F-2162	4	FHCS, 1/4-20 X 3/4", YZ GR5
4	H-2589	1	OIL DRAIN VALVE	30	F-2132	4	NUT, 1/4-20, NYLOC FLANGED
5	H-2761	1	HOSE, 1/2" x 19"	31	D-3881	2	TIRE, 22x11-10, TURF
6	F-2113	1	7/16-20x2-1/2" CAPSCREW, GR8	32	F-1499	8	LUG NUT, 1/2 X 20
7	621-113P	1	KEY, 1/4 SQ. X 1-1/4"	33	707-036P	1	BRACE, TRANSMISSION
8	H-2751	1	MUFFLER, KOHLER, LOW MOUNT	34	707-086P	1	HYDRO MOUNT BRACE, R
9	F-2043	1	SPACER	---	707-087P	1	HYDRO MOUNT BRACE, L
10	H-2404	1	CHOKE CABLE	35	F-2127	4	FHCS, 1/2-13 X 1-1/4" GR5
11	H-2611	1	THROTTLE CABLE	36	F-2145	2	5/16-18 X 6" BOLT GR8
12	P-10077-11	1	DECAL, "CLEAN"	37	H-2762	1	VENT TUBE ADAPTER
13	F-1228	1	SETSCREW, 1/4" X 1/4"	38	659-173P	1	HYDRO BRACE
14	659-121P	2	REAR HYDRO BRACE	39	F-2178	4	FHCS, 5/16-18 X 3", YZ GR5
15	707-085P	1	MOTOR PULLEY	40	707-061P	2	FAN SHROUD
16	D-3882-01	1	TRANSAXLE, RH, ZT-3400	41	F-1009-03	2	3/8" FLAT WASHER
17	D-3882-02	1	TRANSAXLE, LH, ZT-3400	42	F-1005-03	1	3/8-16 LOCK NUT
18	F-1009-01	4	1/4" FLAT WASHER	43	F-2177	2	FHCS, 5/16-18 x 2-1/2", YZ GR5
19	H-2759	1	MUFFLER, KAWASAKI	44	F-1492	2	5/16-3/8 RUE RING
20	707-074P	2	FREEWHEEL CHAIN W/SPRING	45	H-2567	2	TRANSAXLE OIL FILTER
21	707-009W	1	MOTOR MOUNT	46	H-2549	1	HOSE 5" LONG
22	H-2539	2	FAN BLADE REPLACEMENT	47	D-3791	2	SMALL HYDRO TANK
23	659-092P	2	WHEEL BACKING PLATE	48	F-1307	4	3/8-16 x 1-1/4" CAPSCREW
24	F-2007	1	3/8-16 X 12-1/2" HEX BOLT	49	F-1019-03	4	3/8" LOCK WASHER
25	F-2152	4	NUT, 1/2-13, NYLOC FLANGED	50	H-2517	1	VENT TUBE ADAPTER
26	F-1009-02	14	5/16" FLAT WASHER	51	H-2762	1	VENT TUBE ADAPTER

**MOTOR & TRANSMISSION  
ASS'Y & RELATED PARTS  
FOR 27HP BRIGGS & STRATTON**

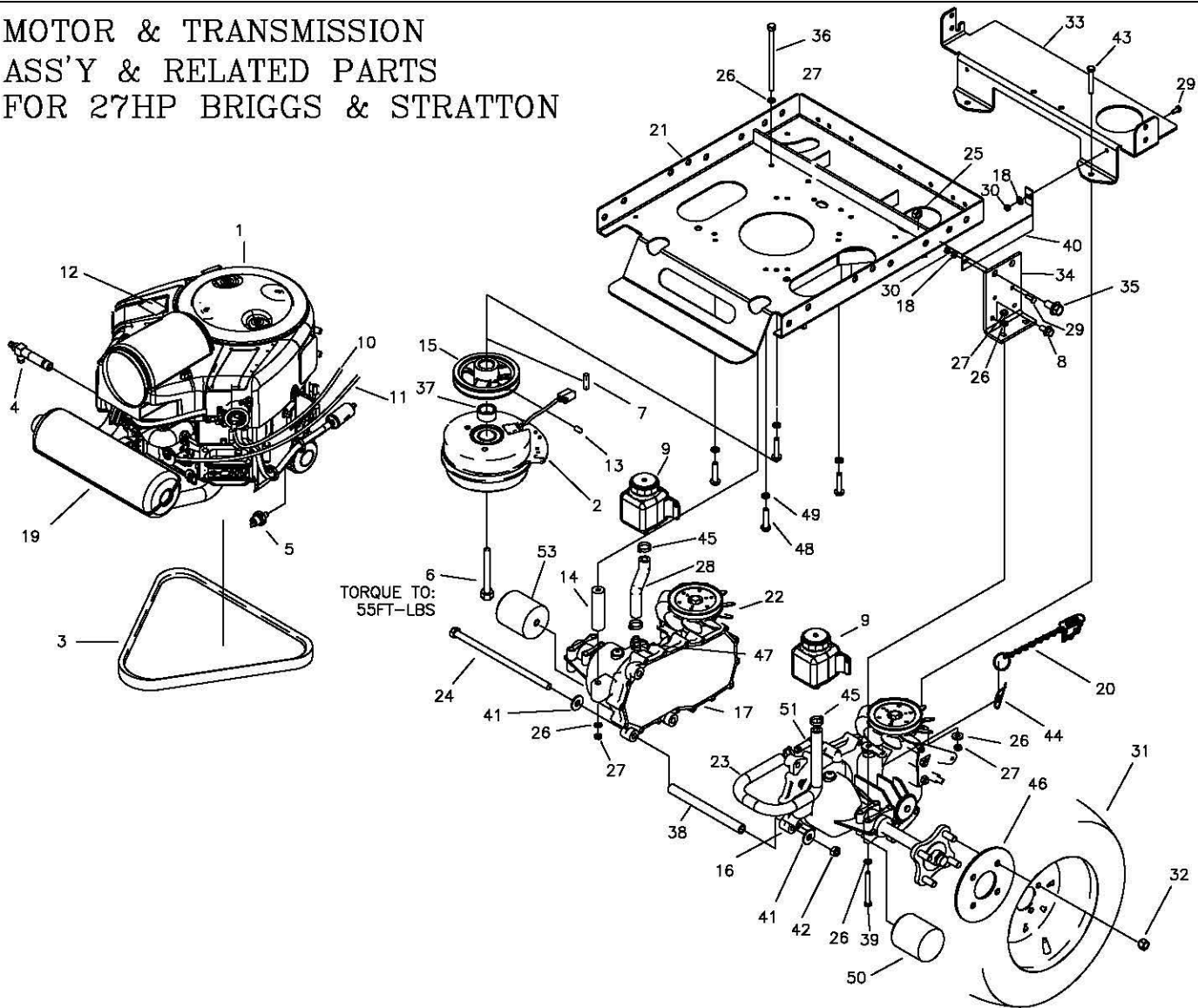

ITEM #	PART #	QTY	DESCRIPTION	ITEM #	PART #	QTY	DESCRIPTION
1	M-5388	1	ENGINE, 27HP, BRIGGS & STRATTON	27	F-2063	10	NUT, 5/16-18, NYLOC FLANGED
2	E-6532	1	CLUTCH-BRAKE, CMS 200ft/lb	28	H-2549	1	HOSE 5" LONG
3	D-3905	1	V-BELT, KEVLAR CORD, A-69	29	F-2162	4	FHCS, 1/4-20 X 3/4", YZ GR5
4	H-2589	1	OIL DRAIN VALVE	30	F-2132	4	NUT, 1/4-20, NYLOC FLANGED
5	E-6307	1	OIL PRESSURE SWITCH	31	D-3881	2	TIRE, 22x11-10, TURF
6	F-2113	1	7/16-20x2-1/2" CAPSCREW, GR8	32	F-1499	8	LUG NUT, 1/2 X 20
7	621-113P	1	KEY, 1/4 SQ. X 1-1/4"	33	707-036P	1	BRACE, TRANSMISSION
8	F-2124	2	FHCS, 5/16-18 X 3/4" BOLT GR5	34	707-086P	1	HYDRO MOUNT BRACE, R
9	D-3791	2	SMALL HYDRO TANK	---	707-087P	1	HYDRO MOUNT BRACE, L
10	H-2404	1	CHOKE CABLE	35	F-2127	4	FHCS, 1/2-13 X 1-1/4" GR5
11	H-2612	1	THROTTLE CABLE	36	F-2145	2	5/16-18 X 6" BOLT GR8
12	P-10077-11	1	DECAL, "CLEAN"	37	F-2043	1	SPACER
13	F-1228	1	SETSCREW, 1/4" X 1/4"	38	659-173P	1	HYDRO BRACE
14	659-121P	2	REAR HYDRO BRACE	39	F-2178	4	FHCS, 5/16-18 X 3", YZ GR5
15	707-085P	1	MOTOR PULLEY	40	707-061P	2	FAN SHROUD
16	D-3882-01	1	TRANSAXLE, RH, ZT-3400	41	F-1009-03	2	3/8" FLAT WASHER
17	D-3882-02	1	TRANSAXLE, LH, ZT-3400	42	F-2151	1	NUT, 3/8-16, NYLOC FLANGED
18	F-1009-01	4	1/4" FLAT WASHER	43	F-2177	2	FHCS, 5/16-18 X 2-1/2", YZ GR5
19	H-2744	1	MUFFLER, BRIGGS	44	F-1492	2	5/16-3/8 RUE RING
20	707-074P	2	FREEWHEEL CHAIN W/SPRING	45	H-2535	4	HOSE CLAMP
21	707-009W	1	MOTOR MOUNT	46	659-092P	2	WHEEL BACKING PLATE
22	H-2539	2	FAN BLADE REPLACEMENT	47	H-2517	1	VENT TUBE ADAPTER
23	H-2761	1	HOSE, 1/2" x 19"	48	F-1307	4	3/8-16 x 1-1/4" CAPSCREW
24	F-2007	1	3/8-16 X 12-1/2" HEX BOLT	49	F-1019-03	4	3/8" LOCK WASHER
25	F-2152	4	NUT, 1/2-13, NYLOC FLANGED	50	H-2567	2	TRANSAXLE OIL FILTER
26	F-1009-02	14	5/16" FLAT WASHER	51	H-2762	1	VENT TUBE ADAPTER

# E-6415 WIRE HARNESS & RELATED PARTS

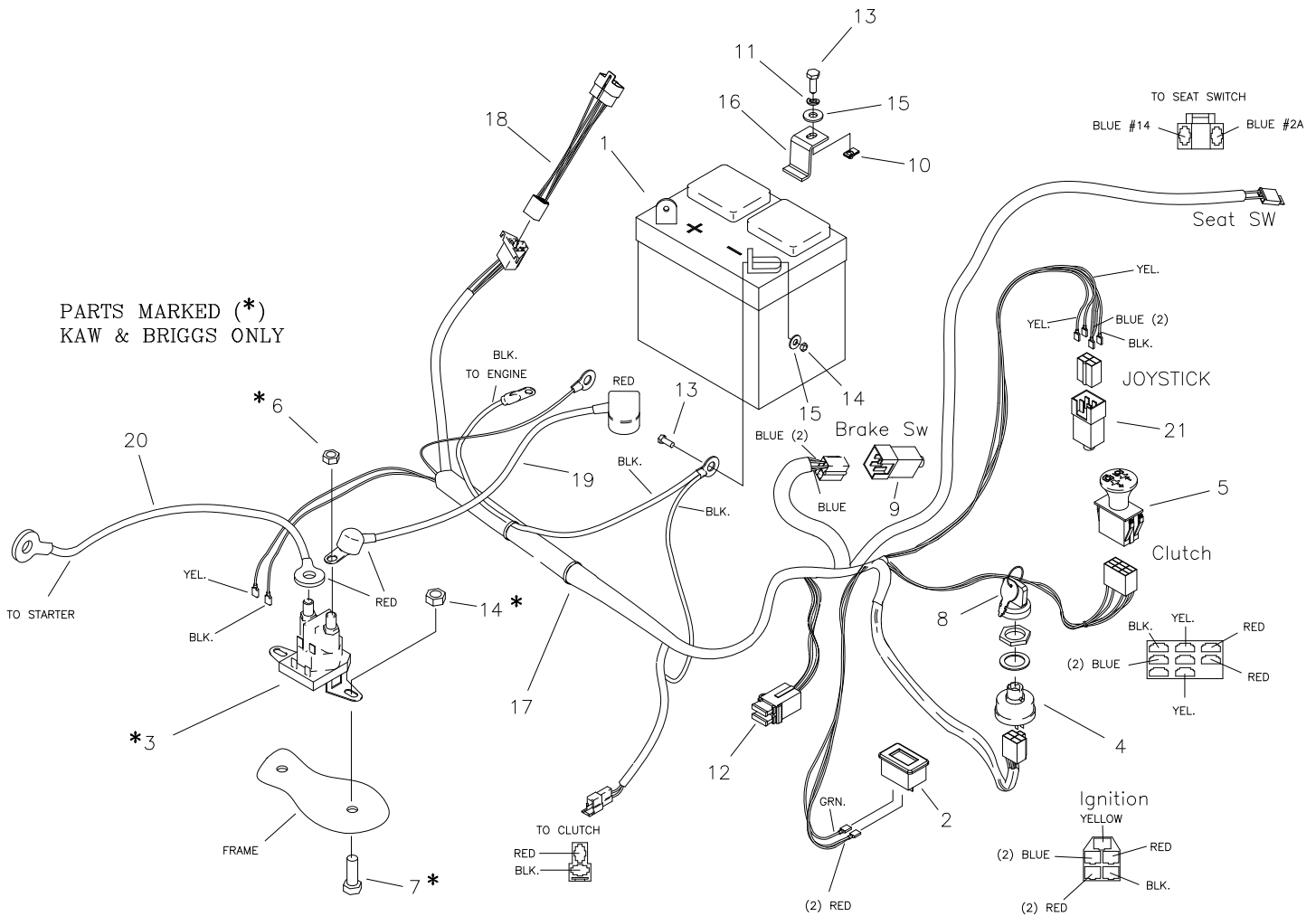

PARTS MARKED (\*)  
KAW & BRIGGS ONLY

ITEM #	PART #	QTY	DESCRIPTION
1	E-6271	1	BATTERY
2	E-5878	1	HOUR METER
3	E-6054	1	SOLENOID
4	E-5873	1	START SWITCH (INCLUDES #8)
5	E-6403	1	CLUTCH SWITCH
6	F-1011-01	2	1/4-20 NUT
7	F-1015-02	2	1/4-20 x 5/8" CAPSCREW
8	E-6445	1	KEY, SET
9	E-6297	1	BRAKE SWITCH
10	F-1858	1	1/4-20 U-NUT
11	F-1019-01	1	1/4" LOCK WASHER
12	E-6207	2	FUSE, #ATC-30
13	F-1538	3	1/4-20 x 3/4" CAPSCREW
14	F-1158	5	1/4-20 STOVER NUT
15	F-1009-01	5	1/4" FLAT WASHER
16	659-137P	1	BATTERY HOLD DOWN
17	E-6415	1	WIRE HARNESS
18	E-6417	1	WIRE HARNESS ADAPTER (KAWASAKI)
-	E-6436	1	WIRE HARNESS ADAPTER (BRIGGS)
19	E-6418	1	CABLE, BATTERY TO SOLENOID
20	E-6419	1	CABLE, SOLENOID TO ENGINE
21	E-6474	1	JOYSTICK SWITCH
-NOT SHOWN-			
	E-6374	1	SEAT SWITCH FOR KAW & KOHLER
	E-6580	1	SEAT SWITCH FOR BRIGGS

# WIRE HARNESS ADAPTER & RELATED PARTS FOR KAWASAKI

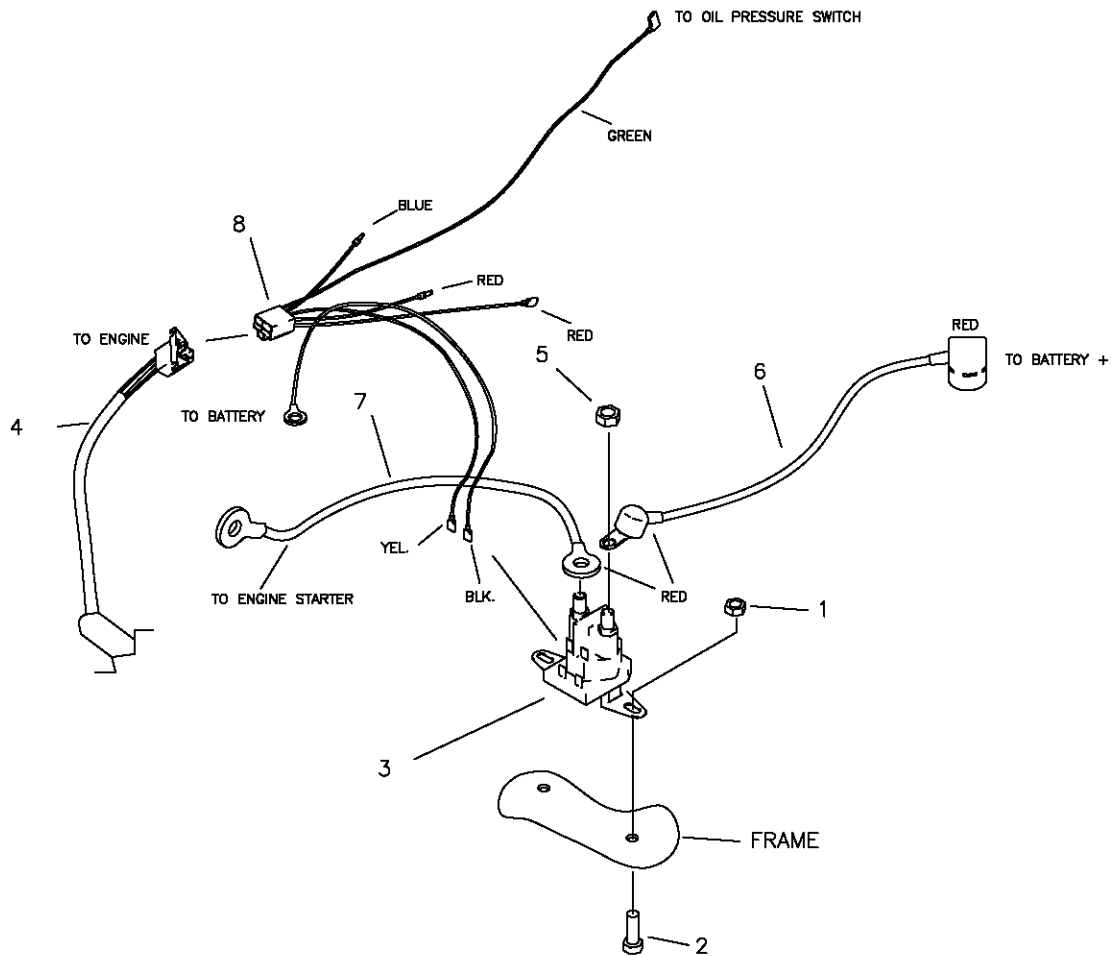

ITEM #	PART #	QTY	DESCRIPTION
1	F-2132	2	NUT, 1/4-20, NYLOC FLANGED
2	F-2162	2	FHCS, 1/4-20 X 3/4", YZ GR5
3	E-6054	1	SOLENOID
4	E-6415	1	WIRE HARNESS
5	F-1011-01	2	1/4-20 NUT
6	E-6418	1	CABLE, BATTERY TO SOLENOID
7	E-6419	1	CABLE, SOLENOID TO ENGINE
8	E-6417	1	KAWASAKI HARNESS ADAPTER

E-6436 WIRE HARNESS  
 ADAPTER & RELATED  
 PARTS FOR BRIGGS

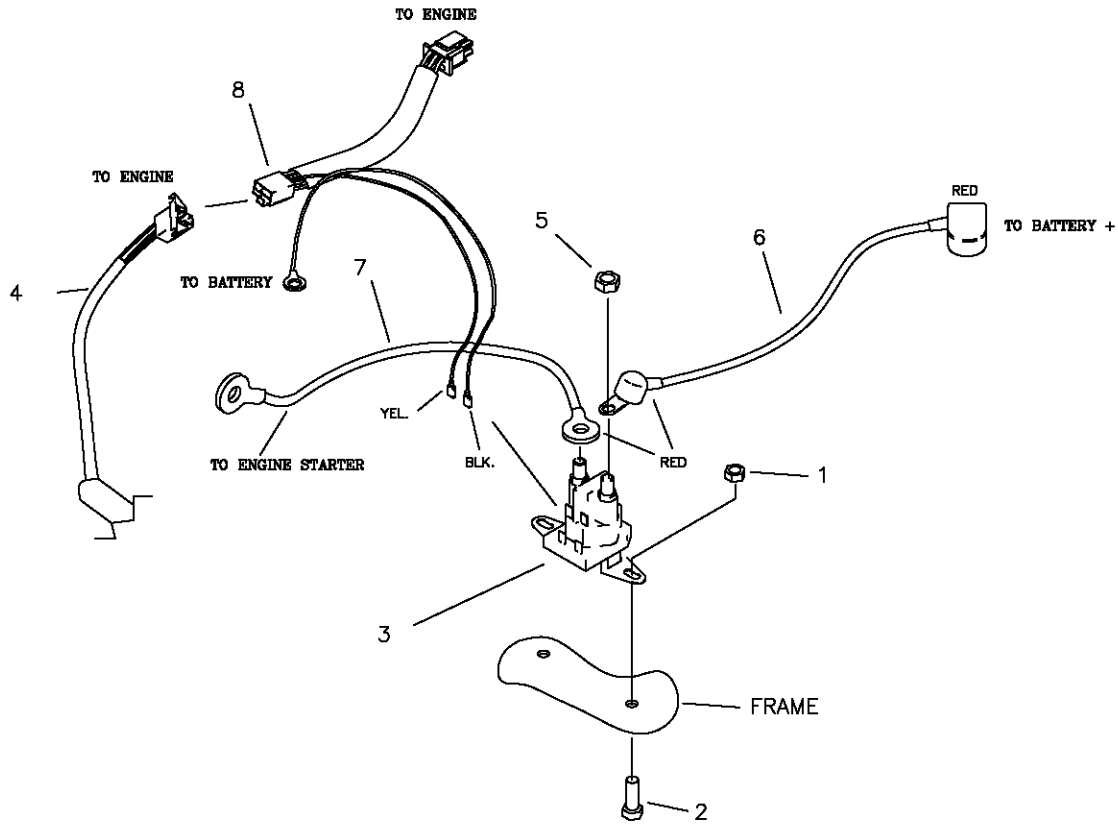

ITEM #	PART #	QTY	DESCRIPTION
1	F-2132	2	NUT, 1/4-20, NYLOC FLANGED
2	F-2162	2	FHCS, 1/4-20 X 3/4", YZ GR5
3	E-6054	1	SOLENOID
4	E-6415	1	WIRE HARNESS
5	F-1011-01	2	1/4-20 NUT
6	E-6418	1	CABLE, BATTERY TO SOLENOID
7	E-6419	1	CABLE, SOLENOID TO ENGINE
8	E-6436	1	ENGINE ADAPTER



# Repair Parts Manual



# CHALLENGER™

# 515

**Country Clipper Division**  
Shivvers Manufacturing Inc.  
613 W. English St.  
Corydon, IA 50060-0467  
Ph. 641-872-2544  
Fax. 641-872-1593

**P-13219**