

Repair Parts Manual

COUNTRY
CLIPPER®
ZERO TURN MOWER

BOSS XL

1510

Congratulations for buying a **Country Clipper** product. Your **Country Clipper** Zero Turning Radius Riding Mower was designed and built to provide long and trouble free service. Keep in mind that it, like any other mechanical device, can be potentially dangerous if used improperly, and hazard control and accident prevention are dependent upon the awareness, concern, prudence, and proper training of personnel involved in the operation, transport, maintenance, and storage of the equipment. Study this manual and pay special attention to the important Safety Precautions on pages 2-4. Following these instructions will help you continue to enjoy the trouble-free performance

COUNTRY CLIPPER

B O S S^{XL}

1510

ZERO TURN RADIUS MOWER

TABLE OF CONTENTS

SECTION 1 – MOWER DECKS AND RELATED PARTS

1. 60" DECK ASSEMBLY
2. 72" DECK ASSEMBLY
3. DECK SPINDLE ASSEMBLY
4. CHUTE ASSEMBLY
5. LIFT HANDLE ASSEMBLY & RELATED PARTS
6. QUICK RELEASE SYSTEM (QRS) PARTS - 60" & 72" DECKS

SECTION 2 – TRACTOR FRAME AND RELATED PARTS

7. LIFT ASSEMBLY & RELATED PARTS - 60" DECK
8. LIFT ASSEMBLY & RELATED PARTS - 72" DECK
9. STEP & RELATED PARTS
10. DOUBLE IDLER & RELATED PARTS
11. ANTI-ROTATING CASTER WHEEL & RELATED PARTS
12. FRAME SIDES & RELATED PARTS
13. FRAME SIDES & RELATED PARTS (CONT)
14. FRAME SIDES & RELATED PARTS (CONT)
15. FENDER ASSEMBLY
16. SEAT FRAMING & RELATED PARTS
17. SEAT FRAMING & RELATED PARTS (CON'T)
18. R.O.P.S. ASSEMBLY (ROLL OVER PROTECTION SYSTEM) & RELATED PARTS

SECTION 3 – TRACTOR DRIVE AND RELATED PARTS

19. FUEL TANK ASSEMBLY
20. JOYSTICK & RELATED PARTS (RIGHT SIDE)
21. JOYSTICK & RELATED PARTS (LEFT SIDE)
22. JOYSTICK ASSEMBLY
23. TWIN STICK STEERING CONTROL & RELATED PART
24. PARKING BRAKE & RELATED PARTS
25. TRANSMISSION & RELATED PARTS
26. HYDRO IDLER & RELATED PARTS
27. ENGINE & RELATED PARTS
28. WIRE HARNESS & RELATED PARTS (JOYSTICK)
29. WIRE HARNESS & RELATED PARTS (TWINSTICK)
30. JACK ASSEMBLY

60" DECK ASS'Y
{643AF-002A}

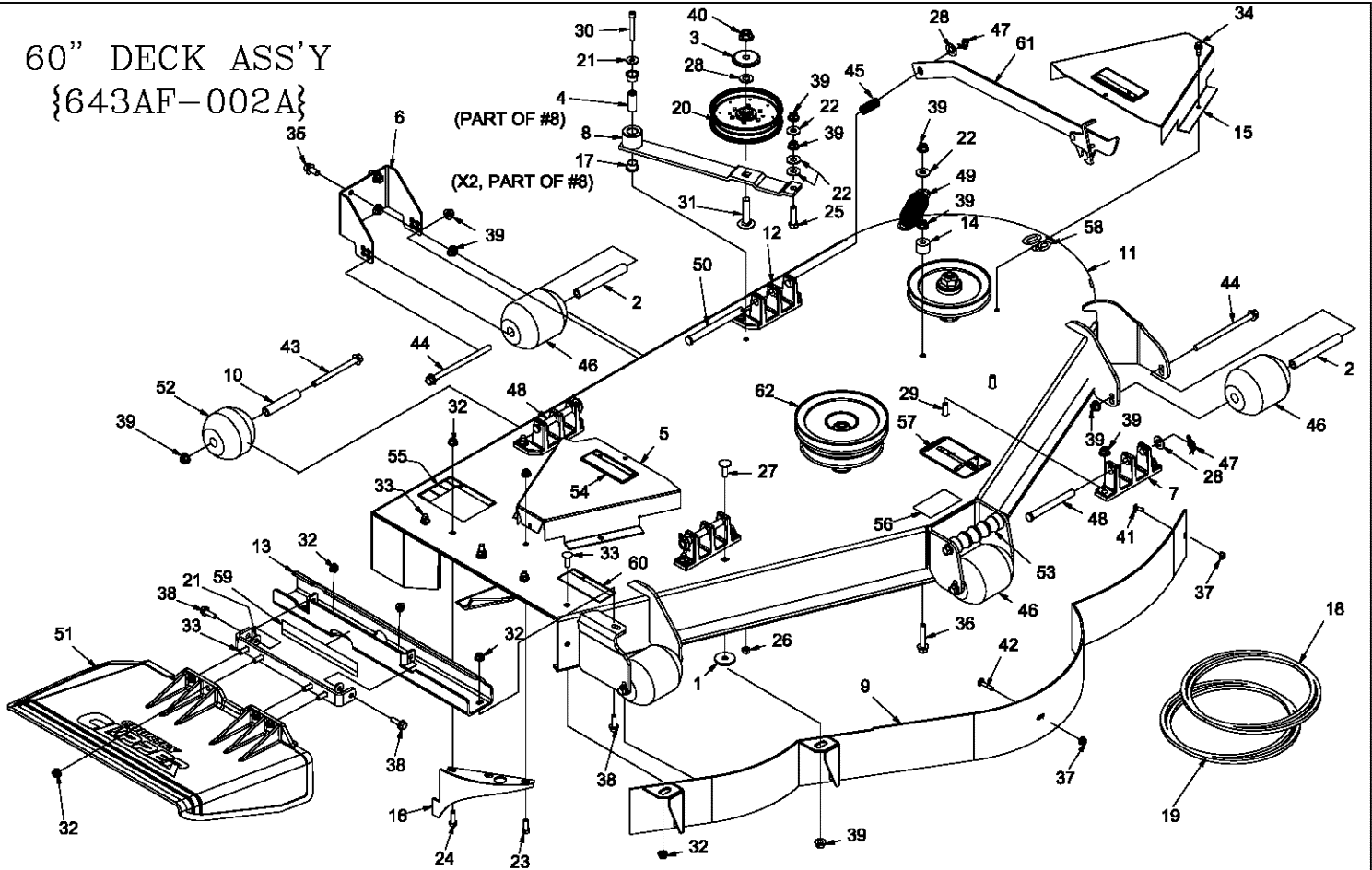

REF NO.	PART NO.	QTY.	DESCRIPTION	REF NO.	PART NO.	QTY.	DESCRIPTION
1	609-034P	13	Spindle Spacer Washer	33	F-2066	8	5/16-18 x 1" CARRIAGE BOLT,
2	609-183P	4	BUSHING	34	F-2119	2	FHCS, 1/4-20 x 0.75, YZ, LOCK PATCH, GR5
3	620-201P	1	WASHER, BEARING CAP	35	F-2124	4	FHCS, 3/8-16 x 0.75, YZ, GR5
4	621-103P	1	MOUNTING PIN	36	F-2126	1	FHCS, 3/8-16 x 2.00, YZ, GR5
5	668-077A	1	PULLEY COVER w/DECALS	37	F-2132	2	NUT, 1/4-20 NYLOC, FLANGED
6	637-006P	1	SCALPER BRKT.	38	F-2148	3	FHCS, 5/16-18 x 1.00, YZ, GR5
7	643-016W	2	Hanger Weldment	39	F-2151	24	Nut, 3/8-16 Nyloc, Flanged
8	643-079A	1	SINGLE IDLER ARM LONG ASS'Y	40	F-2152	1	Nut, 1/2-13 Nyloc, Flanged
9	643-104W	1	60" DUST BAFFLE WELDMENT	41	F-2155	1	Carriage Bolt, 1/4 X 5/8"
10	643-126P	2	BUSHING	42	F-2157	1	CARRIAGE BOLT, 1/4 X 1-1/4"
11	643-143A	1	60" DECK w/DECALS	43	F-2160	2	FHCS, 3/8-16 x 4 1/2", YZ, GR5
12	651-009W	2	CASTING, HANGER, WIDE BASE	44	F-2161	5	FHCS, 3/8-16 x 6", YZ, GR5
13	660-120P	1	OUTLET STIFFENER, SMALL	45	F-2575	1	SPRING, COMP .656 X .052 X 1.97
14	668-045P	1	SPACER, SPRING MTG	46	H-1948	4	Roller, 3-3/4 DIA. x 4-13/16L
15	668-061A	1	PULLEY COVER w/DECALS	47	H-2239	4	1/2" Rue Ring
16	686-006W	1	SPLITTER BAFFLE	48	H-2240	3	1/2" x 4-1/2" Clevis Pin
17	D-3730	2	FLANGED BUSHING	49	H-2619	1	SPRING, 5 X 1-1/2, TAPERED ENDS
18	D-3796	1	V-BELT B-124 DAYCO	50	H-2718	1	1/2" x 5-1/2" Clevis Pin
19	D-3901	1	V-BELT, B-112"	51	H-2723	1	Chute, Discharge, Small
20	D-3904	1	PULLEY, FLAT IDLER, 5" (NTN)	--	643-111A	1	CHUTE ASSEMBLY
21	F-1009-02	3	5/16" Flat Washer	52	H-2772	2	Roller, 3-3/4 DIA. x 3 1/4"L
22	F-1009-03	4	3/8" Flat Washer	53	H-2787	1	GRIP, DECK HANDLE
23	F-1015-14	1	5/16-18 x 7/8" Capscrew	54	P-10935	2	Decal, WARNING
24	F-1015-15	1	5/16-18 x 1" Capscrew	55	P-10941	1	DECAL "DANGER ROTATING BLADES"
25	F-1015-27	1	3/8-16 x 1-1/2" Capscrew	56	P-11413	1	DECAL, HOIST POINT
26	F-1125	1	5/16-18 Stover Nut	57	P-11935	1	Decal, Belt Routing
27	F-1274	1	3/8-16 X 1" CARRIAGE BOLT	58	P-11952	1	DECAL, DECK SIZE, 60
28	F-1521	5	1/2" WASHER, CUSTOM	59	P-12496	1	DECAL, MISSING CHUTE
29	F-1672	8	3/8-16 x 1-1/4" Carriage Bolt	60	P-12706	1	WARNING DECAL, DISCHARGE CHUTE
30	F-1800	1	5/16-18 SHSC 2-1/4"	61	625-114A	1	DECK PROP ASSEMBLY
31	F-1822	1	1/2-13 X 2-1/4" CARRIAGE BOLT	62	-----	3	SPINDLE ASS'Y (SEE pg.3)
32	F-2063	13	Nut, 5/16-18 Nyloc, Flanged				

72" DECK ASS'Y
 {643AD-002A}

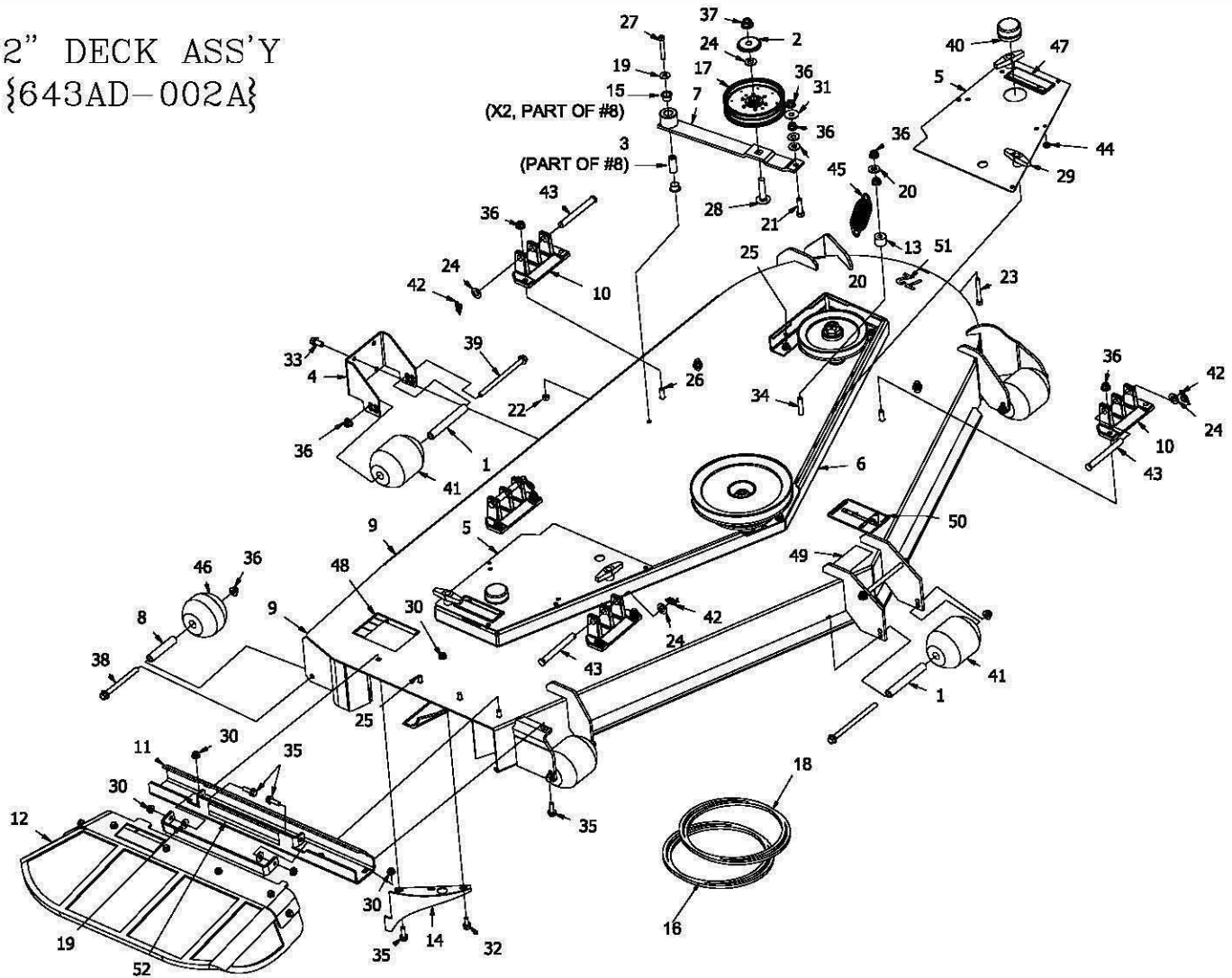

REF NO.	PART NO.	QTY.	DESCRIPTION	REF NO.	PART NO.	QTY.	DESCRIPTION
1	609-183P	4	BUSHING	27	F-1800	1	5/16-18 SHSC 2-1/4"
2	620-201P	1	WASHER, BEARING CAP	28	F-1822	1	1/2-13 X 2-1/4" CARRIAGE BOLT
3	621-103P	1	MOUNTING PIN	29	F-1921	4	T HANDLE KNOB
4	637-006P	1	SCALPER BRKT.	30	F-2063	29	Nut, 5/16-18 Nyloc, Flanged
5	643-095A	1	PULLEY COVER w/DECALS (RH)	31	F-2083	1	WASHER, 3/8 FENDER
-	643-132A	1	PULLEY COVER w/DECALS (LH)	32	F-2120	1	FHCS, 5/16-18 x 0.75, YZ, GR5
6	643-068P	1	TOP STIFFNER 72" DECK	33	F-2124	4	FHCS, 3/8-16 x 0.75, YZ, GR5
7	643-079A	1	SINGLE IDLER ARM LONG ASS'Y	34	F-2126	1	FHCS, 3/8-16 x 2.00, YZ, GR5
8	643-126P	2	BUSHING	35	F-2148	4	FHCS, 5/16-18 x 1.00, YZ, GR5
9	643-142A	1	72" DECK w/DECALS	36	F-2151	23	Nut, 3/8-16 Nyloc, Flanged
10	651-009W	4	CASTING, HANGER, WIDE BASE	37	F-2152	1	Nut, 1/2-13 Nyloc, Flanged
11	660-123P	1	OUTLET STIFFENER, LARGE	38	F-2160	2	FHCS, 3/8-16 x 4 1/2", YZ, GR5
12	660-125A	1	RUBBER CHUTE ASSEMBLY, LARGE	39	F-2161	5	FHCS, 3/8-16 x 6", YZ, GR5
13	668-045P	1	SPACER, SPRING MTG	40	H-1798	2	2 GREASE CAP
14	686-006W	1	SPLITTER BAFFLE	41	H-1948	4	Roller, 3-3/4 DIA. x 4-13/16L
15	D-3730	2	FLANGED BUSHING	42	H-2239	4	1/2" Rue Ring
16	D-3797	1	"V"-BELT B-142 DAYCO #7-9535	43	H-2240	4	1/2" x 4-1/2" Clevis Pin
17	D-3904	1	PULLEY, FLAT IDLER, 5" (NTN)	44	H-2461	8	Rubber bumper
18	D-3912	1	"V"-BELT B-116	45	H-2619	1	SPRING, 5 X 1-1/2, TAPERED ENDS
19	F-1009-02	3	5/16" Flat Washer	46	H-2772	2	Roller, 3-3/4 DIA. x 3 1/4"L
20	F-1009-03	3	3/8" Flat Washer	47	P-10935	2	Decal, WARNING
21	F-1015-27	1	3/8-16 x 1-1/2" Capscrew	48	P-10941	1	DECAL "DANGER ROTATING BLADES"
22	F-1125	3	5/16-18 Stover Nut	49	P-11413	1	DECAL, HOIST POINT
23	F-1518	4	5/16-18 x 2-1/2" Capscrew	50	P-11935	1	Decal, Belt Routing
24	F-1521	5	1/2" WASHER, CUSTOM	51	P-11953	1	DECAL, DECK SIZE, 72
25	F-1671	21	5/16-18 x 3/4" CARRIAGE BOLT	52	P-12496	1	DECAL, MISSING CHUTE
26	F-1672	8	3/8-16 x 1-1/4" Carraige Bolt				

TORQUE TO 140 LB-FT 1

PULLEY NOT INCLUDED
IN ASSEMBLY *2

DECK SPINDLE ASSEMBLY 629FN-001A

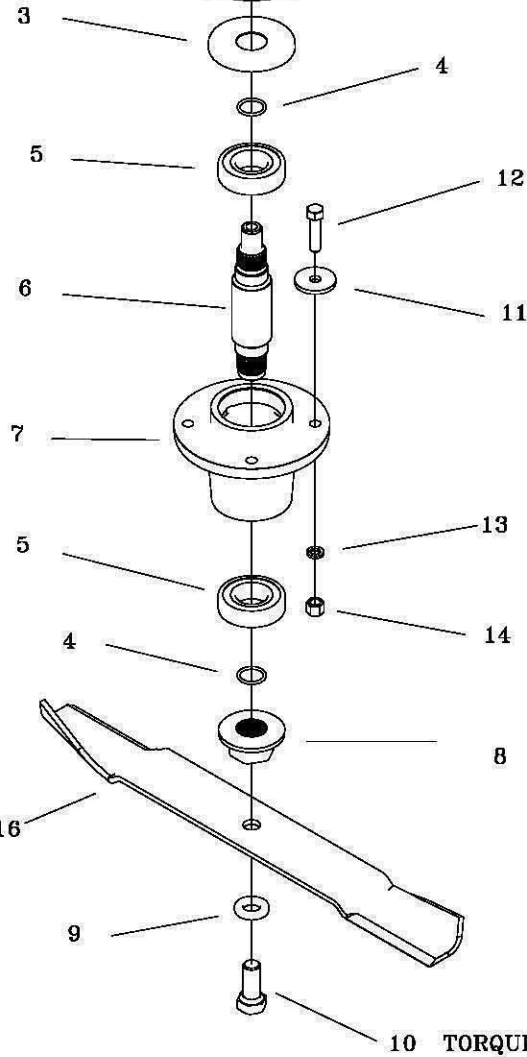

15 (APPLY THIN LAYER OF CHEVRON RYKOTAC GREASE TO THE TOP SURFACES OF THE BEARING AND HOUSING PRIOR TO INSTALLING ITEM #3 (BEARING CAP).

NEW MOWERS ARE SHIPPED WITH 3 to 4 oz OF CHEVRON SRI NLGI 2 GREASE INSIDE EACH SPINDLE HOUSING.

BLADE NOT INCLUDED
IN ASSEMBLY *16

10 TORQUE TO 100 LB-FT

ITEM	PART #	QTY.	DESCRIPTION	ITEM	PART #	QTY.	DESCRIPTION
1	F-2078	1	3/4-6 TOP LOCK NUT	15	H-2707	1	GREASE PACKET
2	668-043P	*	60" DECK CENTER PULLEY (SHOWN)	16	H-2886	*	FUSION, HIGH LIFT, 60" DECK
*	668-044P	*	72" DECK CENTER PULLEY	-	H-2887	*	FUSION, HIGH LIFT, 72" DECK
*	668-042P	*	60" & 72" DECK OUTSIDE PULLEY	OPTIONAL BLADES			
3	609-292P	1	CAP, BEARING				
4	H-2639	2	O'RING, RUBBER				
5	D-3867	2	BEARING, #6206				
6	609-289P	1	SHAFT, SPINDLE				
7	609-285P	1	HOUSING, SPINDLE				
8	609-288P	1	BLADE DRIVER				
9	660-099P	1	BLADE WASHER				
10	F-2073	1	5/8-11 X 1.5 HHCS GR. 8				
11	609-034P	4	SPINDLE SPACER, WASHER				
12	F-1572	4	3/8-24 X 1.5 CAP SCREW	*	H-2655	*	BLADE, HIGH LIFT 60" DECK
13	F-1019-03	4	3/8 LOCK WASHER	*	H-2656	*	BLADE, HIGH LIFT 72" DECK
14	F-1573	4	3/8-24 LOCK NUT	*	H-2661	*	BLADE, LOW LIFT 60" DECK
				*	H-2662	*	BLADE, LOW LIFT 72" DECK
				*	H-2667	*	BLADE, GATOR 60" DECK
				*	H-2877	*	BLADE, GATOR 72" DECK

RUBBER CHUTE ASSEMBLY 660-125A (72" DECK)

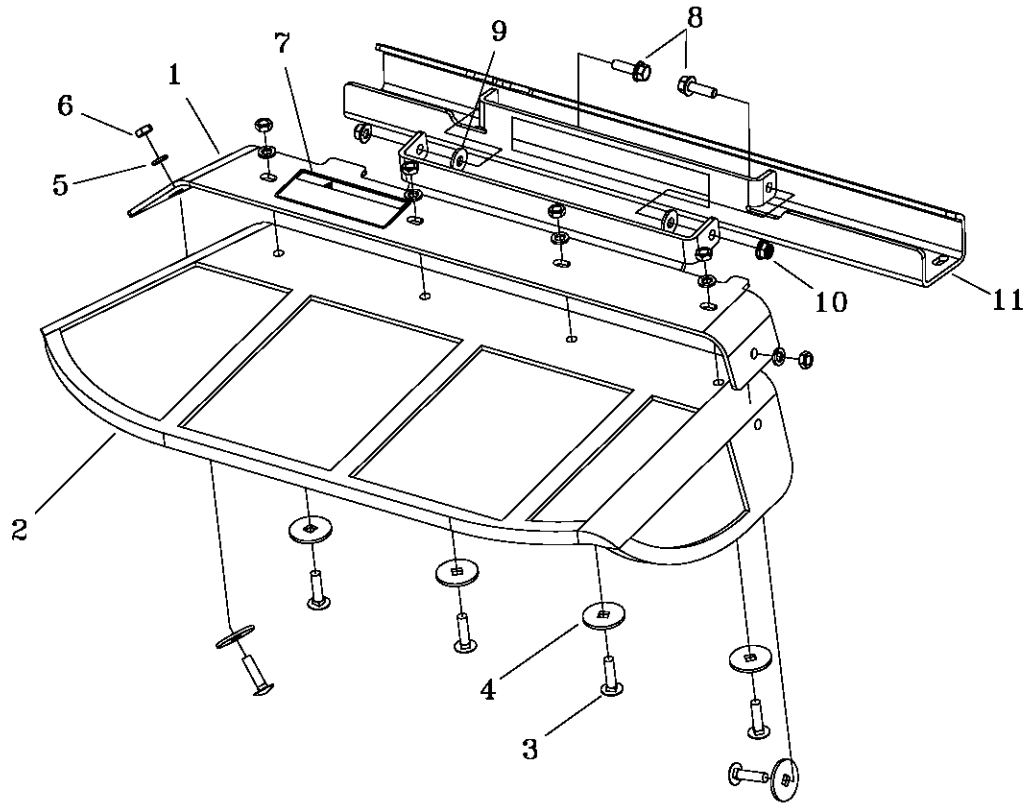

MOLDED CHUTE ASSEMBLY 643-111A (60" DECK)

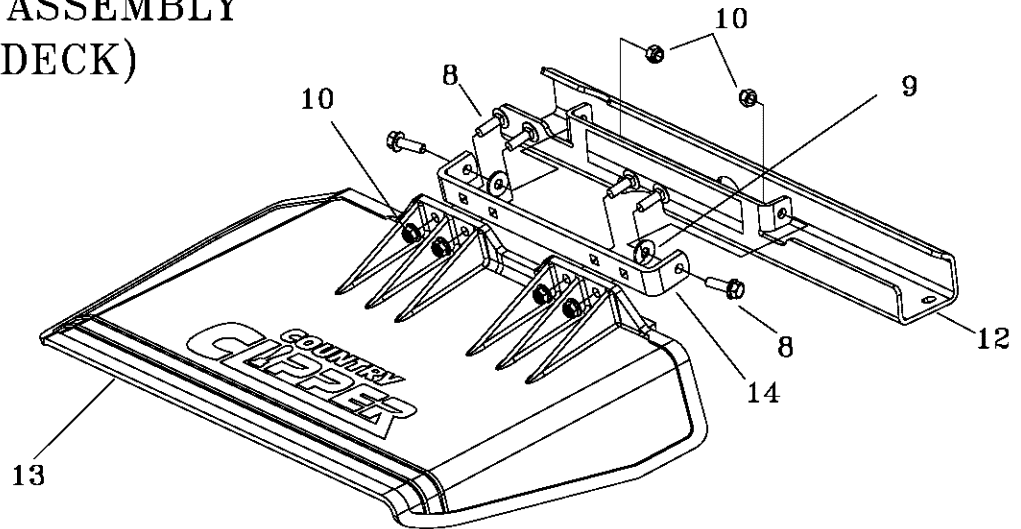

ITEM	PART #	QTY.	DESCRIPTION
1	643-134A	1	CHUTE FRAME w/DECALS, LG.
2	H-2683	1	RUBBER CHUTE, LG.
3	F-1106	6	5/16-18 X 1-1/4 CARRIAGE BOLT
4	660-130P	6	RUBBER CHUTE WASHER
5	F-1019-02	6	5/16 LOCK WASHER
6	F-1011-02	6	5/16-18 NUT
7	P-12706	1	WARNING DECAL, DISCHARGE CHUTE
8	F-2148	2	FHCS, 5/16-18 X 1 YZ, GR5
9	F-1009-02	2	5/16 FLAT WASHER
10	F-2063	2	NUT, 5/16-18 NYLOC FLANGED
11	643-133A	1	OUTLET STIFFENER w/DECAL, LARGE (SEE pg.2)
12	643-135A	1	OUTLET STIFFENER w/DECAL, SMALL (SEE pg.1)
13	H-2723	1	CHUTE, DISCHARGE, SMALL
14	643-110P	1	CHUTE HINGE

LIFT HANDLE ASSEMBLY & RELATED PARTS

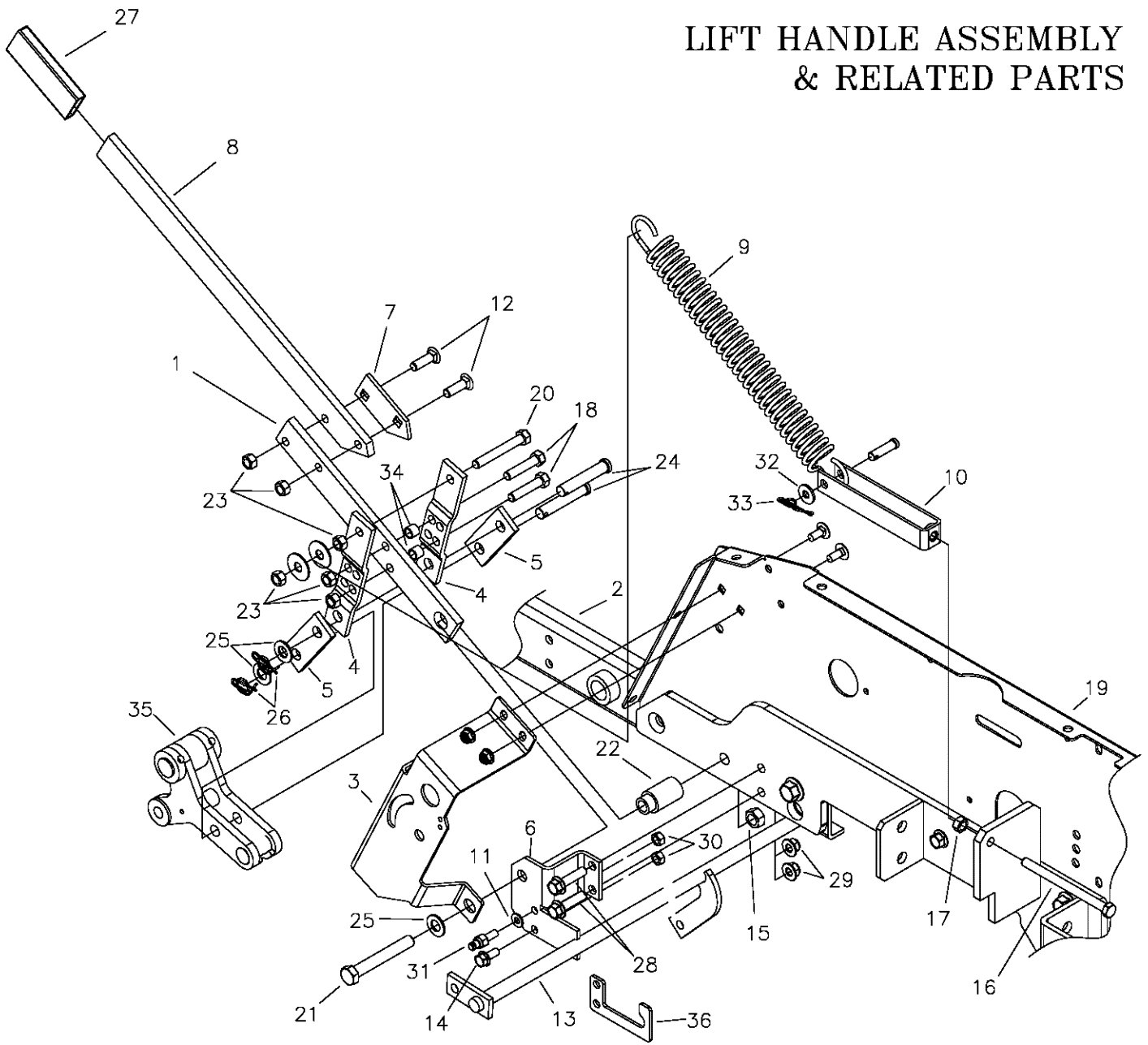

ITEM	PART #	QTY.	DESCRIPTION	ITEM	PART #	QTY.	DESCRIPTION
1	709-139P	1	BAR, LIFT HANDLE, LOWER	18	F-1015-28	2	CAPSCREW, 3/8-16x1-3/4" GR5
2	709-054W	1	FRAME SIDE WELDMENT, LH.	19	709-016P	1	SIDE PANEL, LH
3	709-184P	1	BRACKET, INNER BRAKE MNT	20	F-1542	1	CAPSCREW, 3/8-16x2 3/4" GR5
4	642-060P	2	SPRING ANCHOR PLATE	21	F-1828	1	1/2-13 X 3-1/2" GR. 5
5	642-061P	2	HANDLE LINK	22	642-095P	1	HANDLE PIVOT PIN
6	709-075P	1	BRACKET, HANDLE PIVOT	23	F-1005-03	6	NUT, 3/8-16 LOCKNUT (STOVER)
7	709-140P	1	PLATE, TOP PEG CATCH	24	F-1889	2	CLEVIS PIN, 1/2 X 2-5/8"
8	709-101P	1	BAR, LIFT HANDLE, UPPER	25	F-1521	3	1/2" FLAT WASHER
9	H-1610	1	SPRING, 1-1/2" OD. X 8"	26	H-2239	2	RUE RING, 1/2"
	H-1868	1	SPRING, HEAVY 8" (72" DECK)	27	H-2324	1	VINYL GRIP, 3/8 X 1-1/2"
10	709-062W	1	YOKE, SPRING WLDT	28	F-2147	2	FHCS, 3/8-16x1-1/2", YZ, GR5
11	F-1009-01	1	FLAT WASHER, 1/4"	29	F-2151	2	NUT, 3/8-16, NYLOC, FLANGED
12	F-1672	2	3/8-16 X 1-1/4" CARRIAGE BOLT	30	F-1125	2	5/16-18, STOVER NUT
13	709-116W	1	BRAKE ROD WLDT	31	638-028P	1	DAMPER BOLT, 5/16-18x3/4"
14	F-2120	1	FHCS, 5/16-18x3/4", YZ, GR5	32	F-1009-02	1	FLAT WASHER, 5/16"
15	F-1005-05	2	NUT, 1/2-13 LOCKNUT	33	F-1492	1	5/16-3/8 RUE RING
16	F-1646	1	3/8-16 X 5" FULL THREAD	34	629-532P	2	SPACER
17	F-1011-03	1	HEX NUT, 3/8-16 UNC-2B	35	642-193P	1	REAR LIFT SLEEVE
				36	709-117P	1	BRACKET, BRAKE LINK

QRS SYSTEM PARTS

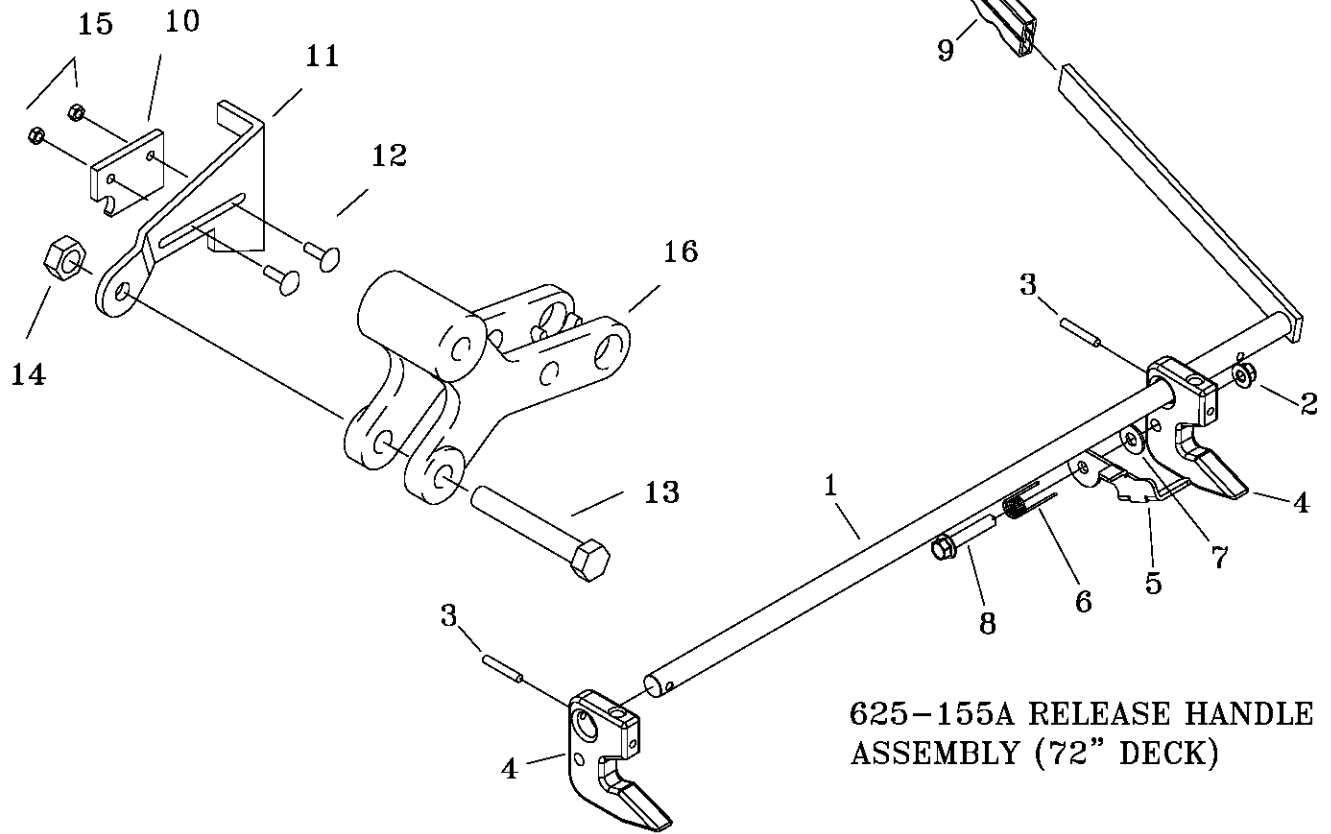

625-155A RELEASE HANDLE ASSEMBLY (72" DECK)

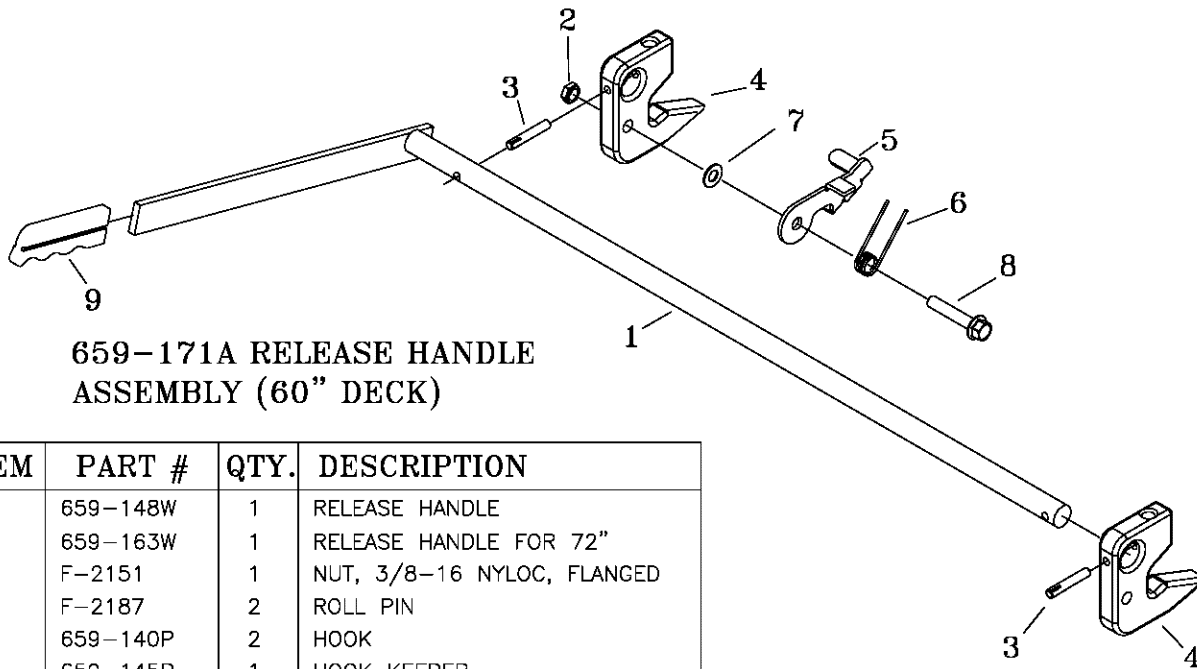

659-171A RELEASE HANDLE ASSEMBLY (60" DECK)

ITEM	PART #	QTY.	DESCRIPTION
1	659-148W	1	RELEASE HANDLE
-	659-163W	1	RELEASE HANDLE FOR 72"
2	F-2151	1	NUT, 3/8-16 NYLOC, FLANGED
3	F-2187	2	ROLL PIN
4	659-140P	2	HOOK
5	659-145P	1	HOOK KEEPER
6	H-2547	1	SPRING
7	F-1009-03	1	3/8" FLAT WASHER
8	F-2126	1	FHCS, 3/8-16x2", YZ, GR5
9	H-1926	1	1/4x1 HANDLE GRIP
10	659-170P	1	CATCH
11	663-089P	1	LATCH PLATE
12	F-1823	2	1/4 X 3/4" CARRIAGE BOLT
13	F-2163	1	FHCS, 1/2-13x3-1/2", YZ GR5
14	F-2152	1	NUT, 1/2-13 NYLOC, FLANGED
15	F-1158	1	1/4-20 STOVER NUT
16	642-193P	1	REAR LIFT SLEEVE

LIFT ASSEMBLY & RELATED PARTS 60" DECK

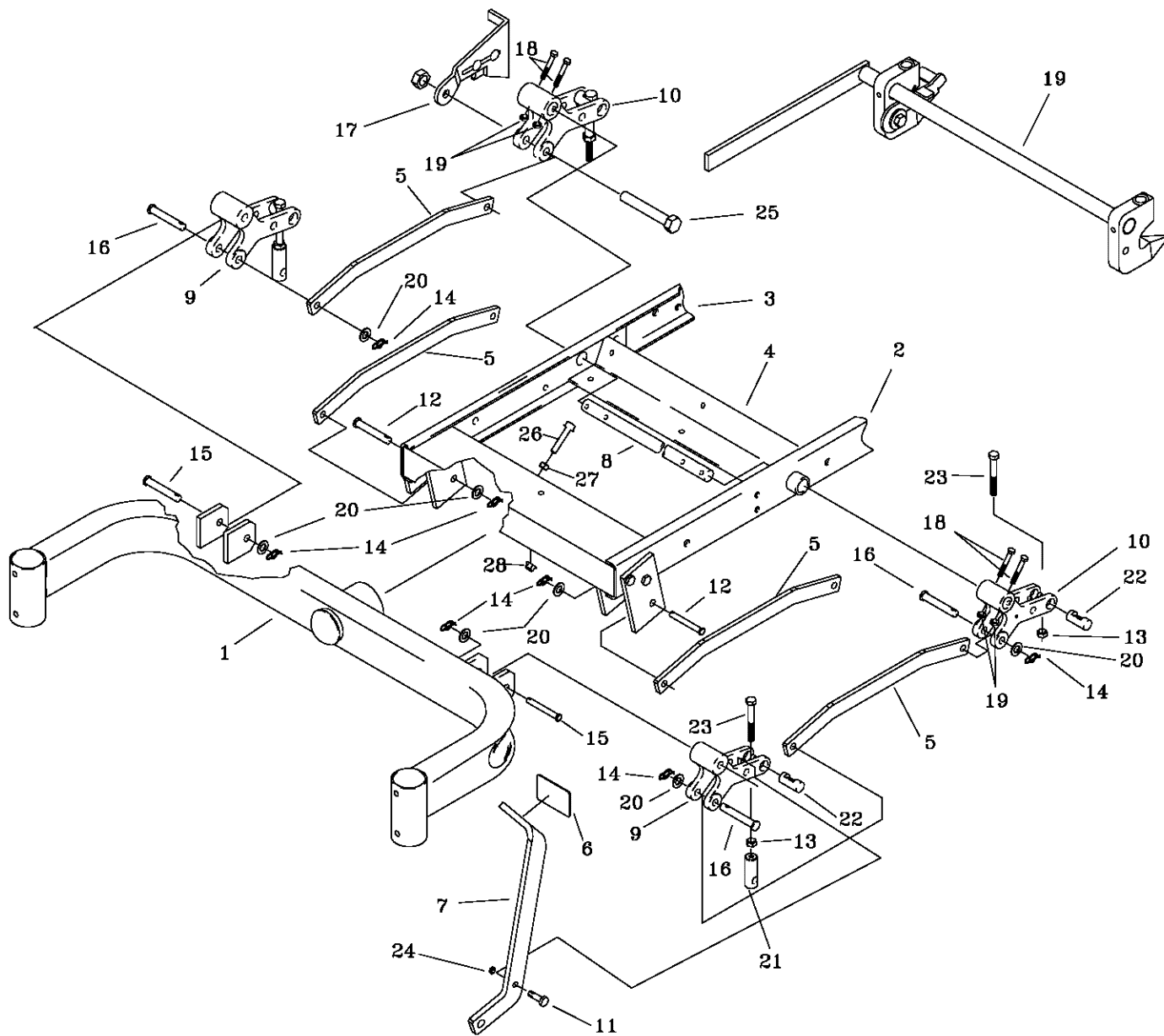

ITEM	PART #	QTY.	DESCRIPTION	ITEM	PART #	QTY.	DESCRIPTION
1	642-189W	1	FRONT AXLE WELDMENT	17	----	1	QRS SYSTEM, SEE PAGE #6
2	709-054W	1	FRAME SIDE WLDT, LH	18	F-2039	4	5/16-24 x 2" HHCS
3	709-055W	1	FRAME SIDE WLDT, RH	19	F-2041	4	5/16-24 LOCK NUT
4	709-157W	1	FRONT PIVOT CHANNEL	20	F-1521	8	WASHER, 1/2 NARROW
5	659-299P	4	LINK BAR	21	642-175P	2	ADJUSTABLE HANGER END
6	H-2401	1	1-1/2"x2-1/2" SAFETY TREAD	22	642-177P	4	HANGER PIN
7	659-056P	1	DECK LIFT PEDAL	23	F-1936	4	1/2-13 X 3-1/2, 2" THREAD
8	620-051P	1	LIFT BAR	24	F-1125	1	5/16 LOCKNUT
9	642-081P	2	LIFT SLEEVE, FRONT	25	F-2163	1	FHCS, 1/2-13x3-1/2", YZ, GR5
10	642-193P	2	LIFT SLEEVE, REAR	26	F-2126	1	FHCS, 3/8-16 x 2", YZ, GR5
11	F-1879	1	5/16-18 X 1 1/4", GR.5	27	F-1011-03	1	NUT, 3/8-16
12	F-1896	2	CLEVIS PIN, 1/2 X 1-3/4"	28	F-2151	1	NUT, 3/8-16 NYLOC, FLANGED
13	F-1489	4	NUT, 1/2" JAM				
14	H-2239	8	RUE RING, 1/2"				
15	F-1890	2	CLEVIS PIN, 1/2 X 3-1/2"				
16	F-1898	3	CLEVIS PIN, 1/2 X 2-3/4"				

LIFT ASSEMBLY & RELATED PARTS 72" DECK

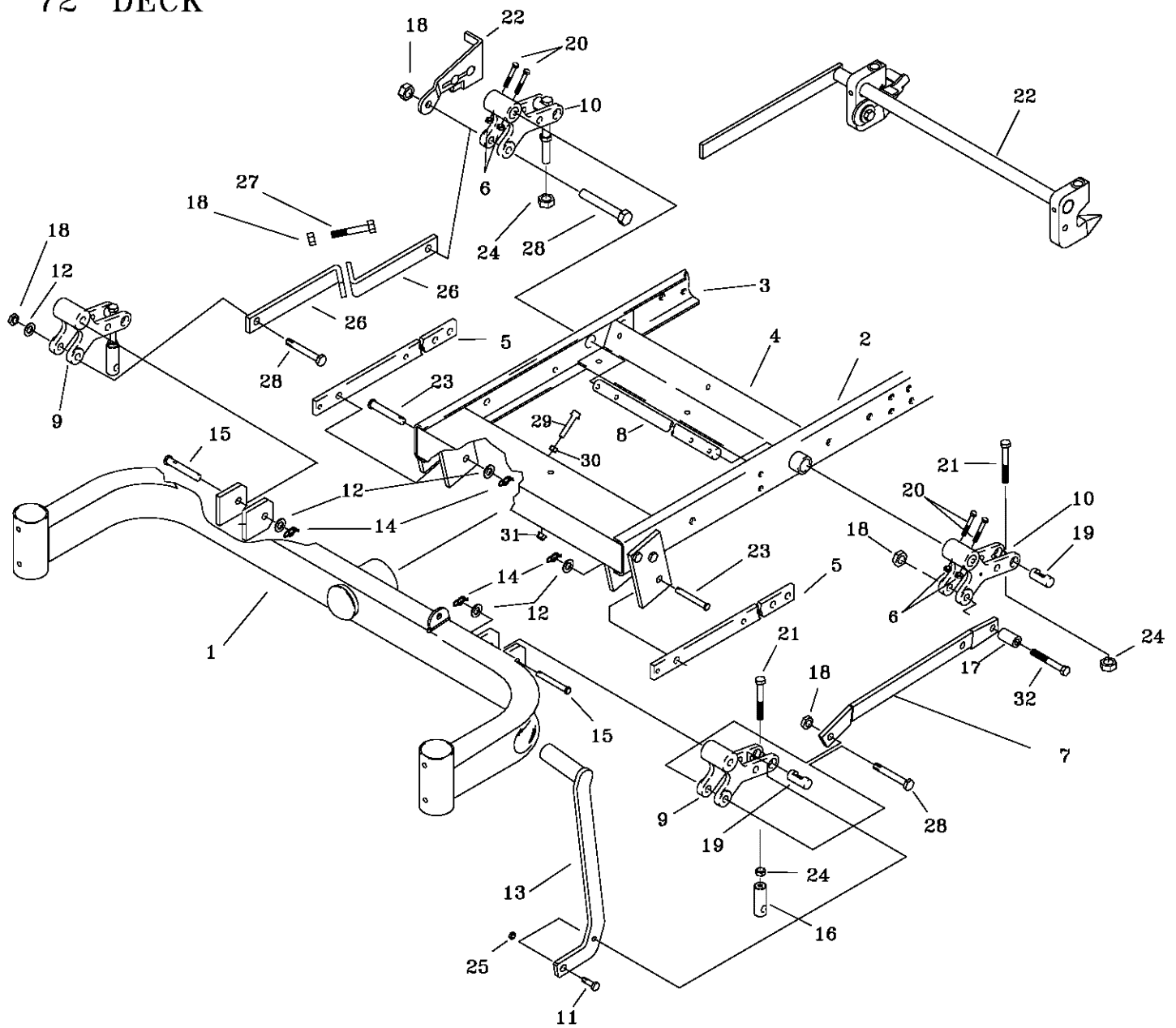

ITEM	PART #	QTY.	DESCRIPTION	ITEM	PART #	QTY.	DESCRIPTION
1	709-171W	1	WIDE FRONT AXLE WELDMENT	17	629-826P	1	SPACER
2	709-254W	1	FRAME SIDE WLDT, LH	18	F-2152	5	NUT, 1/2-13, NYLOC, FLANGED
3	709-255W	1	FRAME SIDE WLDT, RH	19	642-177P	2	HANGER PIN
4	709-157W	1	FRONT PIVOT CHANNEL	20	F-2039	4	5/16-24 x 2" HHCS BOLT
5	642-059P	2	LINK BAR	21	F-1936	4	1/2-13 X 3-1/2, 2" THREAD
6	F-2041	4	5/16-24 LOCKNUT	22	----	1	QRS SYSTEM, SEE PAGE #6
7	647-071P	1	DRAG BAR	23	F-1896	2	CLEVIS PIN, 1/2 X 1-3/4"
8	620-051P	1	LIFT BAR	24	F-1489	4	NUT, 1/2" JAM
9	642-081P	2	LIFT SLEEVE, FRONT	25	F-1125	1	5/16" LOCKNUT
10	642-193P	2	LIFT SLEEVE, REAR	26	647-144P	2	OFFSET LINK BAR ADJUSTABLE
11	F-1879	1	5/16-18 X 1-1/4" BOLT	27	F-2128	1	FHCS, 1/2-13 x 2", YZ, GR5
12	F-1521	6	WASHER, 1/2 NARROW	28	F-2163	3	FHCS, 1/2-13x3-1/2", YZ, GR5
13	629-249W	1	OFFSET DECK LIFT PEDAL	29	F-2126	1	FHCS, 3/8-16 x 2", YZ, GR5
14	H-2239	4	RUE RING, 1/2"	30	F-1011-03	1	NUT, 3/8-16
15	F-1890	2	CLEVIS PIN, 1/2 X 3-1/2"	31	F-2151	1	NUT, 3/8-16 NYLOC, FLANGED
16	642-175P	2	ADJUSTABLE HANGER END	32	F-2181	3	FHCS, 1/2-13x4-1/2", YZ, GR5

STEP & RELATED PARTS

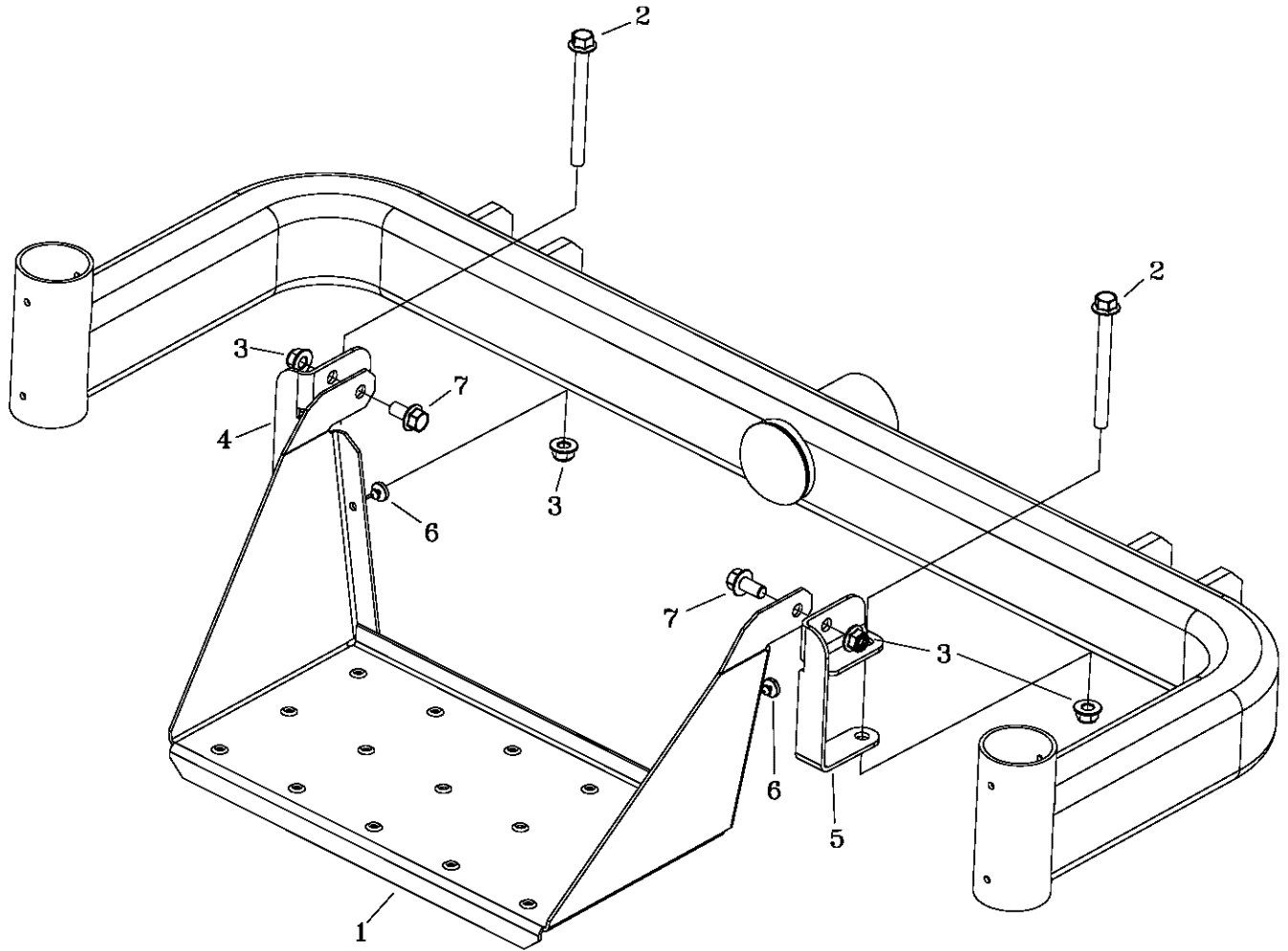

ITEM #	PART #	QTY	DESCRIPTION
1	663-134P	1	STEP, EXTENDED
2	F-2142	2	FHCS, 3/8-16x4", YZ, GR5 (60" ONLY)
3	F-2151	4	NUT, 3/8-16 NYLOC, FLANGED
4	659-241P	1	STEP MOUNT BRACKET, RH (60" ONLY)
5	659-242P	1	STEP MOUNT BRACKET, LH (60" ONLY)
6	H-2461	2	RUBBER BUMPER BUTTON
7	F-2124	2	FHCS, 3/8-16x3/4", YZ, GR5

DOUBLE IDLER & RELATED PARTS

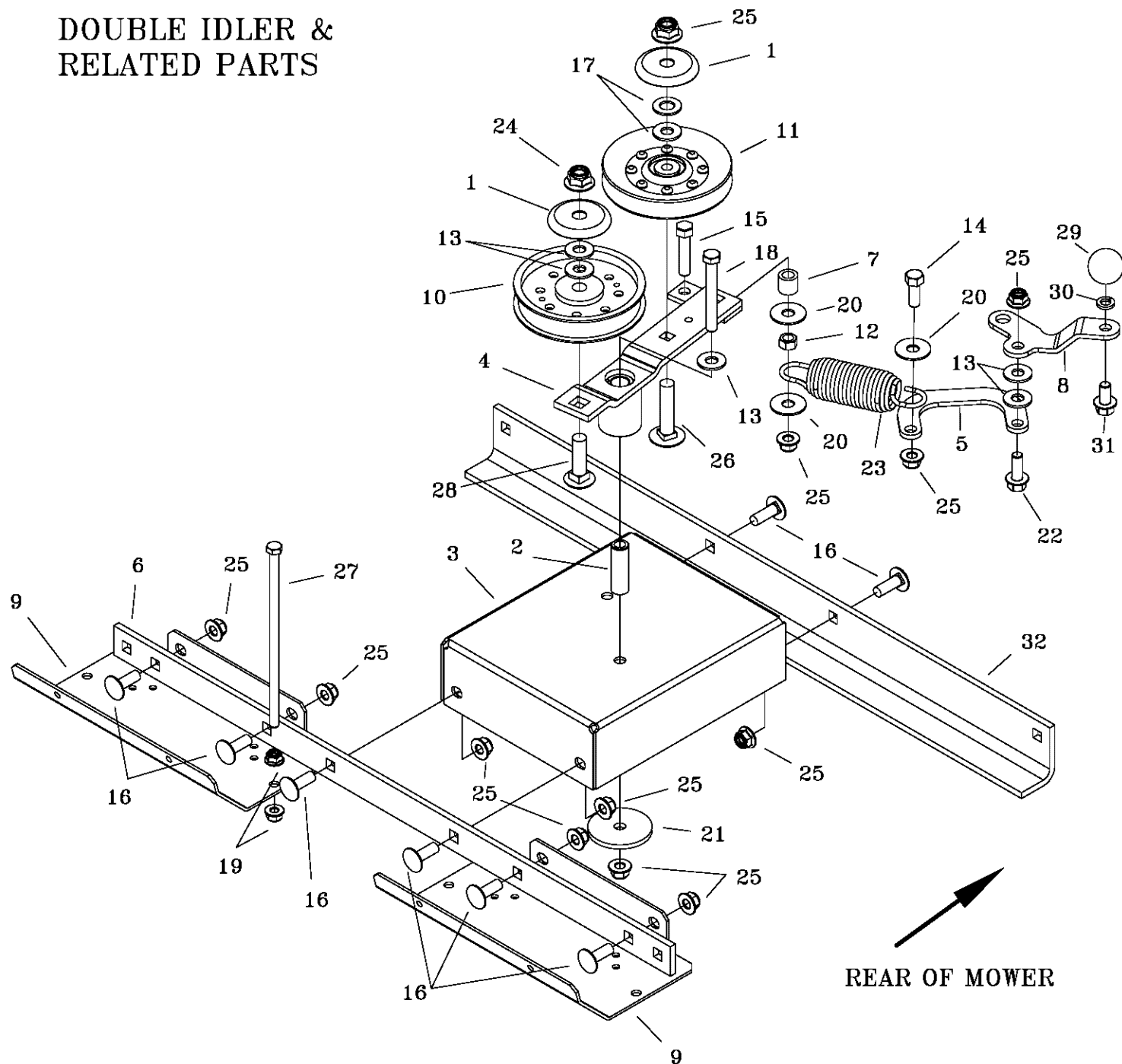

ITEM	PART #	QTY.	DESCRIPTION	ITEM	PART #	QTY.	DESCRIPTION
1	620-201P	2	WASHER, BEARING CAP	17	F-1521	2	1/2" WASHER, CUSTOM
2	709-077P	1	MOUNTING PIN	18	F-2207	1	HHCS, 3/8-16 X 3", YZ, GR8
3	709-085P	1	DECK DRIVE IDLER MOUNT	19	F-2063	2	NUT, 5/16-18 NYLOC, FLANGED
4	709-087A	1	IDLER ARM ASSEMBLY	20	F-2083	3	WASHER, 3/8 FENDER
5	709-088P	1	LINK, BELT TIGHTENING	21	F-2102	1	WASHER, .406ID x 2.25OD x 7GA
6	709-091P	1	CROSS BRACE	22	F-2141	1	FHCS, 3/8-16 X 1", YZ, GR5
7	709-123P	1	SPACER, BELT TENSION	23	H-2619	1	SPRING, 5 x 1-1/2", TAPERED ENDS
8	709-177P	1	HANDLE, BELT TIGHTENER	24	F-2152	1	NUT, 1/2-13 NYLOC, FLANGED
9	709-126P	2	AIR DAM	25	F-2151	12	NUT, 3/8-16 NYLOC, FLANGED
10	D-3922	1	PULLEY, FLAT IDLER, 4.25 O.D.	26	F-1976	1	3/8-16 x 2" CARRIAGE BOLT
11	D-3923	1	PULLEY V-IDLER, 4.59 O.D.	27	F-2156	1	5/16-18 x 8-1/2" CAPSCREW
12	F-1005-03	1	3/8-16 STOVER NUT	28	F-1964	1	1/2-13 x 1-3/4" CARRIAGE BOLT
13	F-1009-03	5	3/8 FLAT WASHER	29	H-2405	1	BALL, 1-1/4", 3/8-16 THRD, BLK
14	F-1394	1	3/8-16 x 1" CAPSCREW	30	F-1019-03	1	LOCK WASHER, 3/8
15	F-1015-28	1	3/8-16 x 1-3/4" CAPSCREW	31	F-2124	1	FHCS, 3/8-16 x 3/4", YZ, GR5
16	F-1274	8	3/8-16 x 1" CARRIAGE BOLT	32	709-187P	1	CROSS BRACE

ANTI-ROTATING CASTER WHEEL & RELATED PARTS

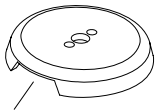

NOTE NOTCH:
TOWARDS REAR OF MOWER

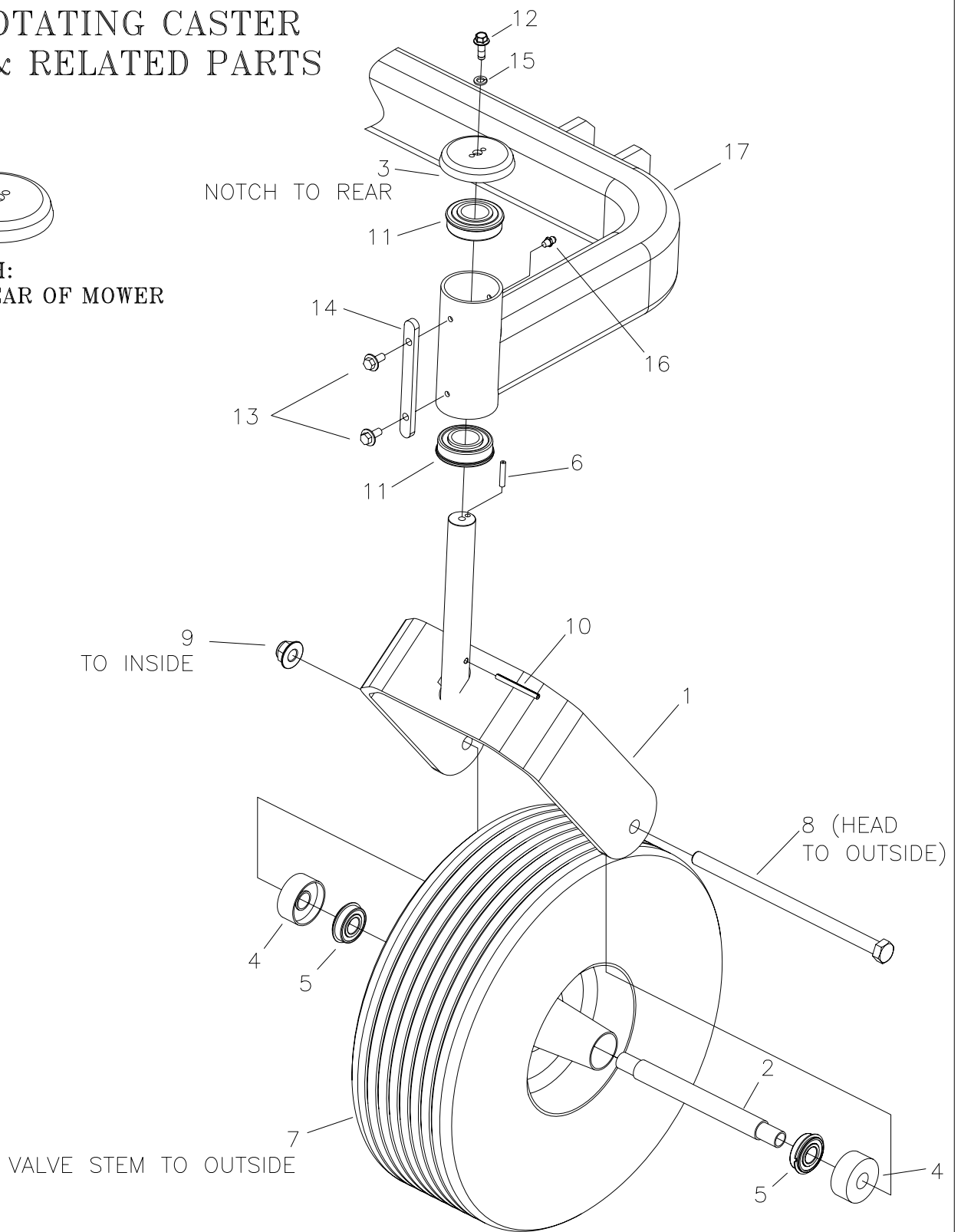

ITEM	PART #	QTY.	DESCRIPTION	ITEM	PART #	QTY.	DESCRIPTION
1	709-043W	1	CASTER WLDT	10	F-1456	1	3/16 x 2" SPIRAL PIN
2	647-038P	1	BEARING SPACER	11	D-2008-02	2	BEARING, SPD SF-16-32
3	636-177P	1	BEARING CAP	12	F-2121	1	FHCS, 5/16-18X3/4", LOCK PATCH
4	611-135P	2	BEARING SHIELD	13	F-2030	2	1/4" x 5/8" SELF TAPPING SCREW
5	D-3432	2	BEARING, 5/8 ID X 1-3/8 OD	14	659-187P	1	STOP TAB
6	F-1855	1	3/16 x 1" ROLL PIN	15	F-1019-02	1	LOCK WASHER, 5/16
7	D-3893	1	TIRE, 15 X 6.00-6 (RIBBED)	16	H-1056	1	GREASE ZERK
8	F-2159	1	1/2-13 X 9-1/2" GR5	17	-----	1	FRONT AXLE WELDMENT (SEE pg.7 OR 8)
9	F-2152	1	NUT, 1/2-13 NYLOCK, GR5				

FRAME SIDES & RELATED PARTS

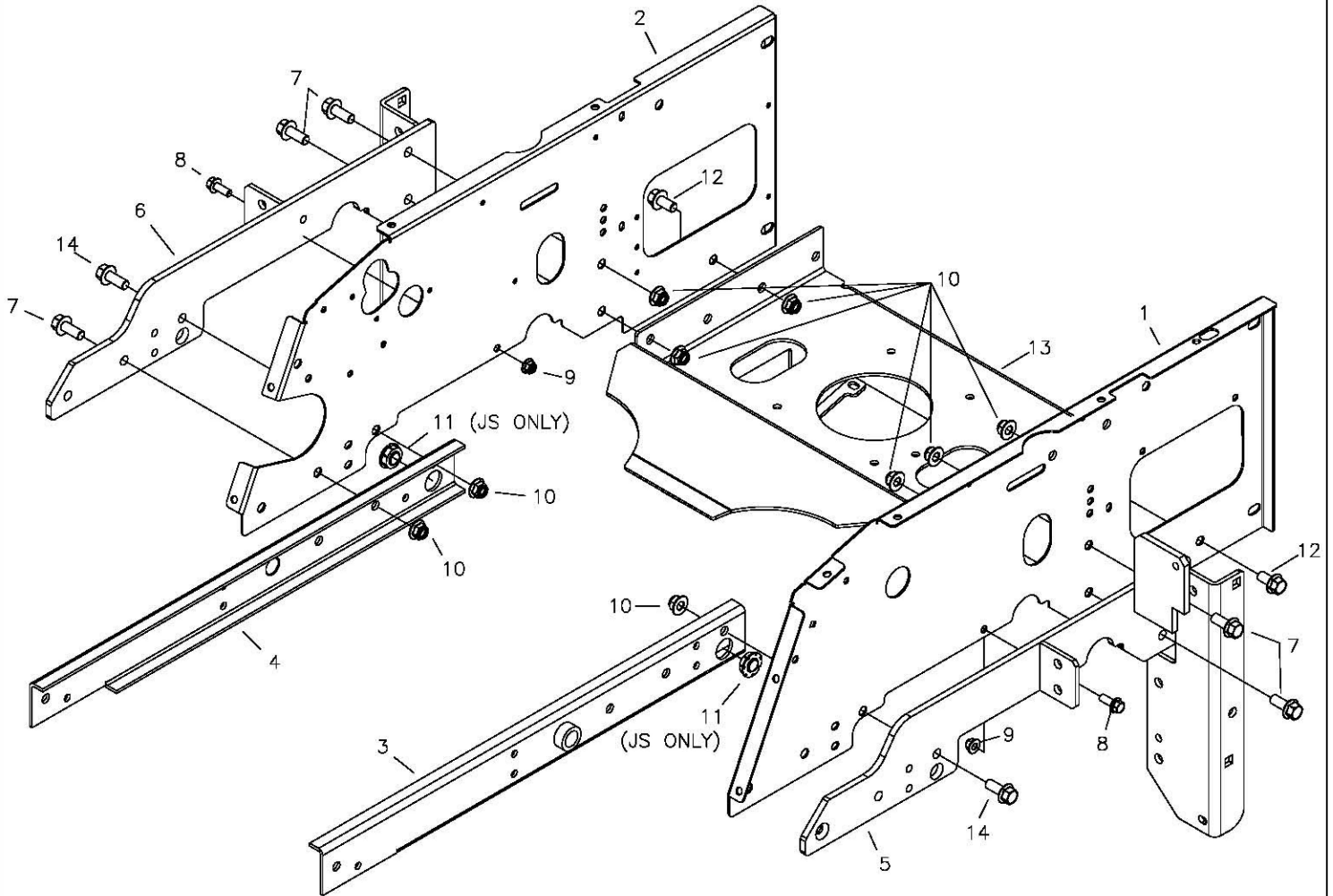

ITEM	PART #	QTY.	DESCRIPTION	ITEM	PART #	QTY.	DESCRIPTION
1	709-016P	1	SIDE PANEL, JS, LH	7	F-2127	5	FHCS, 1/2-13 X 1-1/4, YZ, GR5
-	709-056P	1	SIDE PANEL, TS, LH	8	F-2141	2	FHCS, 3/8-16 x 1", YZ, GR5
2	709-017P	1	SIDE PANEL, JS, RH	9	F-2151	2	NUT, 3/8-16 NYLOC, FLANGED
-	709-076P	1	SIDE PANEL, TS, RH	10	F-2152	9	NUT, 1/2-13 NYLOC, FLANGED
3	709-054W	1	FRAME SIDE WLDT LH	11	H-2773	2	BEARING, FLANGED-SPHERICAL, IGUS
4	709-055W	1	FRAME SIDE WLDT RH	12	F-2143	2	FHCS, 1/2-13x1", YZ, GR5
5	709-080W	1	SIDE PLATE WLDT LH	13	709-009W	1	MOTOR MOUNT WLDT
6	709-081W	1	SIDE PLATE WLDT RH	14	F-2227	2	SHCS, 1/2-13 X 1-1/4, ZINC

FRAME SIDES & RELATED PARTS (CON'T)

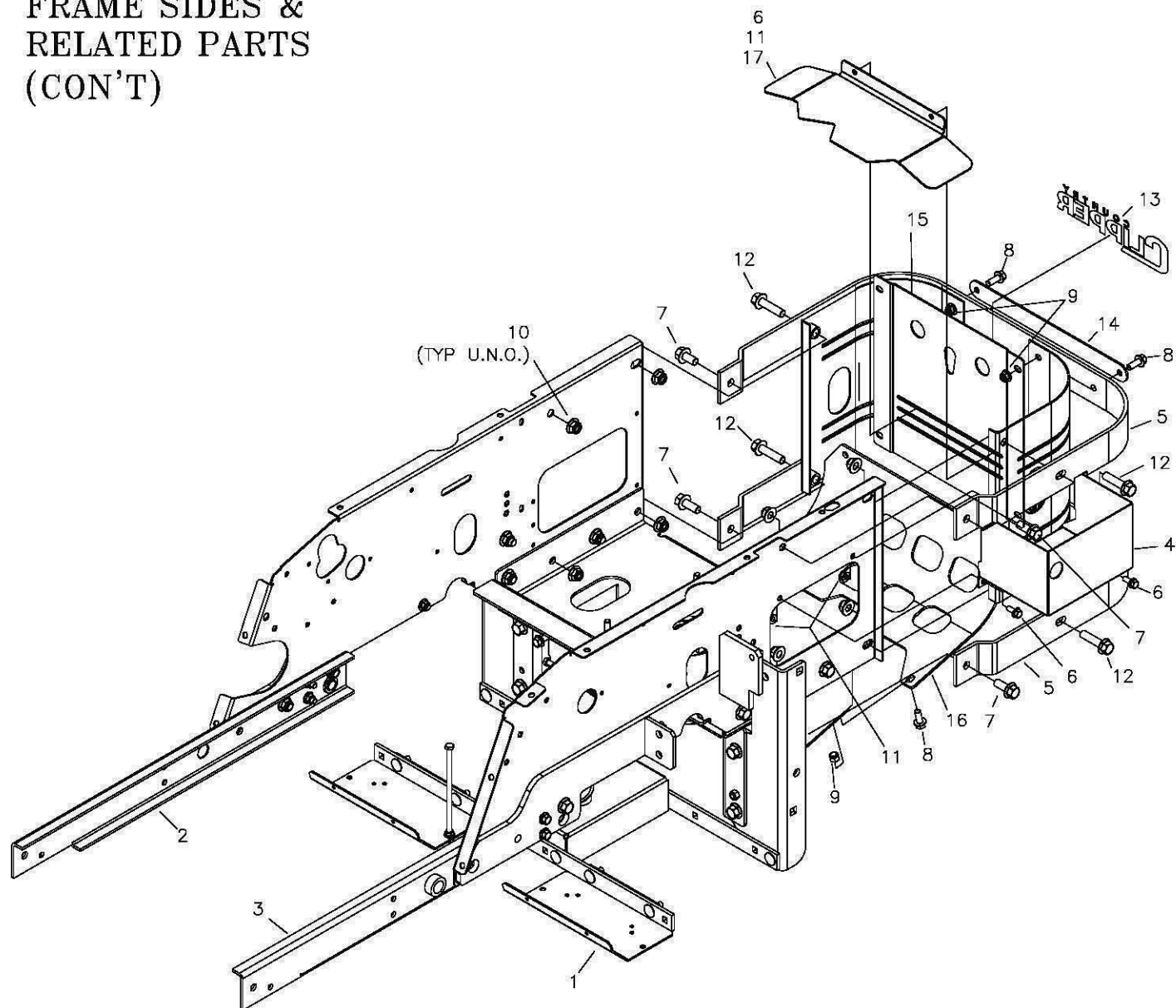

ITEM	PART #	QTY.	DESCRIPTION	ITEM	PART #	QTY.	DESCRIPTION
1	-----	1	DOUBLE IDLER MOUNT (SEE PG.10)	10	F-2152	8	NUT, 1/2-13 NYLOC, FLANGED
2	-----	1	FRAME SIDE (SEE PG.12)	11	F-2063	4	NUT, 5/16-18, NYLOC, FLANGED
3	-----	1	FRAME SIDE (SEE PG.12)	12	F-2128	2	FHCS, 1/2-13x2", YZ, GR5
4	709-022P	1	BATTERY MOUNT BOX	13	P-12986	1	DECAL, NEW CC, LG, CHROME
5	709-098P	2	BAR, REAR ENGINE GUARD	14	H-2912	1	PLACARD, BOSS XL
6	F-2120	4	FHCS, 5/16-18x3/4", YZ, GR5	15	629-895A	1	ENGINE GUARD, w/DECAL
7	F-2127	4	FHCS, 1/2-13x1-1/4", YZ, GR5	16	709-176P	1	PANEL, REAR ENGINE WRAP, LOWER
8	F-2141	6	FHCS, 3/8-16 x 1", YZ, GR5	17	709-218P	1	HEAT SHIELD (KOHLER ONLY)
9	F-2151	6	NUT, 3/8-16 NYLOC, FLANGED				

FRAME SIDES & RELATED PARTS (CON'T)

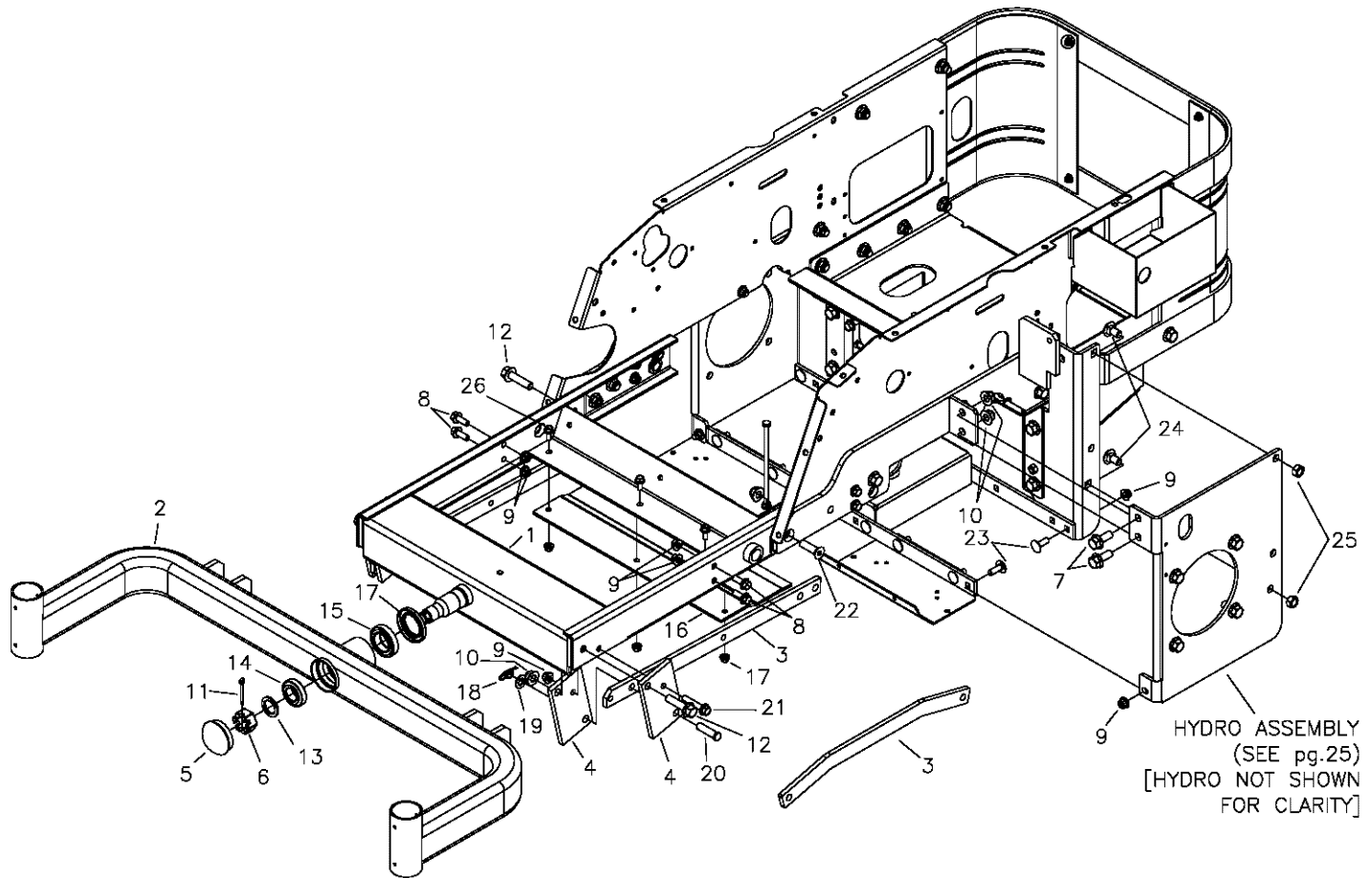

ITEM	PART #	QTY.	DESCRIPTION	ITEM	PART #	QTY.	DESCRIPTION
1	709-157W	1	FRONT PIVOT CHANNEL WLDT	14	D-3826	1	BRG, TAPERED, SET, L44643-L44610
2	642-189W	1	FRONT AXLE WLDT (60" DECK)	15	D-3825	1	BRG, TAPERED, SET, L68149-L68110
-	709-171W	1	FRONT AXLE WLDT (72" DECK)	16	709-100P	1	FUEL TANK SUPPORT
3	-----	2	LINK BAR (72" DECK, SEE pg.8)	17	H-2812	1	SEAL, SHAFT, 1.75x2.375x0.313
-	-----	2	LINK BAR (60" DECK, SEE pg.7)	18	H-2239	2	1/2" RUE RING
4	642-063P	4	DRAG BAR MOUNT TAB	19	F-1521	2	1/2' WASHER, CUSTOM
5	H-1924	1	GREASE CAP	20	F-1896	2	1/2" x 1-3/4", CLEVIS PIN
6	F-1724	1	SLOTTED HEX NUT, 1"-14	21	F-2126	2	FHCS, 3/8-16 x 2", YZ, GR5
7	F-2127	2	FHCS, 1/2-13x1-1/4", YZ, GR5	22	F-2149	1	HEX SCK FLT HD CAP, 1/2-13x1-3/4"
8	F-2141	4	FHCS, 3/8-16 x 1", YZ, GR5	23	F-1274	2	CARRIAGE BOLT, 3/8-16 x 1"
9	F-2151	7	NUT, 3/8-16 NYLOC, FLANGED	24	F-2146	2	CARRIAGE BOLT, 1/2-13 x 1"
10	F-2152	4	NUT, 1/2-13 NYLOC, FLANGED	25	F-1005-05	2	1/2-13 STOVER NUT
11	F-1728	1	3/16" x 2" COTTER PIN	26	F-2120	3	FHCS, 5/16-18 x 3/4", YZ, GR5
12	F-2128	2	FHCS, 1/2-13x2", YZ, GR5	27	F-2063	3	NUT, 5/16-18 NYLOC, FLANGED
13	606-303P	1	1" WASHER				

FENDER ASSEMBLY

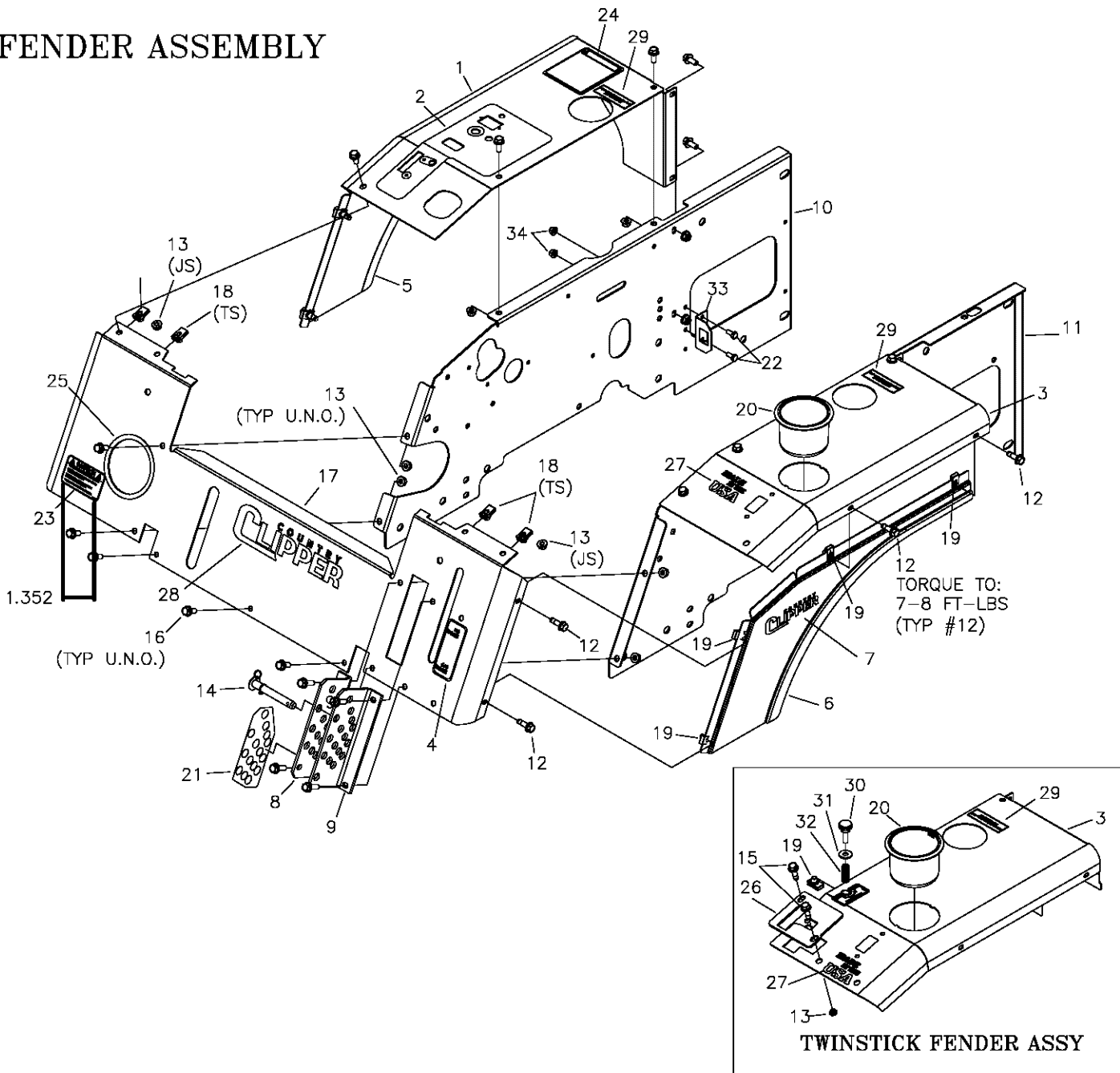

ITEM	PART #	QTY.	DESCRIPTION	ITEM	PART #	QTY.	DESCRIPTION
1	625-157A	1	FENDER CAP w/DECAL, RH, (JS)	16	F-2120	17	FHCS, 5/16-18 X 3/4" GR.5
-	625-159A	1	FENDER CAP w/DECAL, RH, (TS)	17	629-896A	1	FRONT PANEL w/DECALS
-	625-165A	1	FENDER CAP, EFI w/DECAL, RH, (TS)	18	F-1860	4	5/16-18 "U"-NUT
2	P-11369	1	DECAL, CONTROL PANEL (JS)	19	F-1858	8	1/4-20 "U"-NUT
-	P-12682	1	DECAL, CONTROL PANEL (TS)	20	H-2228	1	CUP HOLDER
3	625-158A	1	FENDER CAP w/DECAL, LH (JS)	21	P-12034	1	DECAL, "CUT HEIGHT"
-	625-160A	1	FENDER CAP w/DECAL, LH (TS)	22	F-1015-02	2	CAPSCREW, 1/4-20 x 5/8"
4	P-11382	1	DECAL, PARK BRAKE	23	P-12557	1	DECAL, "CAUTION"
5	629-897A	1	FENDER SKIRT w/DECAL, RH	24	P-11370	1	DECAL, WARNING
6	629-898A	1	FENDER SKIRT w/DECAL, LH	25	H-1626	1	U CHANNEL TRIM
7	P-12991	2	DECAL, NEW CC, SM, CHROME	26	659-262P	2	NEUTRAL PLATE
8	647-097A	1	LATCH PLATE RH W/DECAL	27	P-13000	1	DECAL, "USA"
9	647-095P	1	LATCH PLATE LH.	28	P-12986	1	DECAL, NEW CC, LG, CHROME
10	-----	1	SEE PAGE 12	29	P-11052	2	HYDRO FLUID DECAL
11	-----	1	SEE PAGE 12	30	F-2081	2	KNOB, 5/16-18x1", 7/8" DIA HEAD
12	F-2119	8	FHCS, 1/4-20x3/4", GR.5 w/PATCH	31	F-1009-02	2	5/16" FLAT WASHER
13	F-2063	20	FLANGED NUT, 5-16-18, NYLOC	32	H-1776	2	SPRING, COMP .48 x .0445 x 1.25
14	F-2028	1	LOCK PIN, POSITIVE 1/2" x 2-1/2"	33	647-146P	1	FUSE HOLDER
15	F-2121	4	FHCS, 5/16-18x1" GR.5 w/PATCH	34	F-2132	2	NUT, 1/4-20 NYLOC, FLANGED

SEAT FRAMING & RELATED PARTS

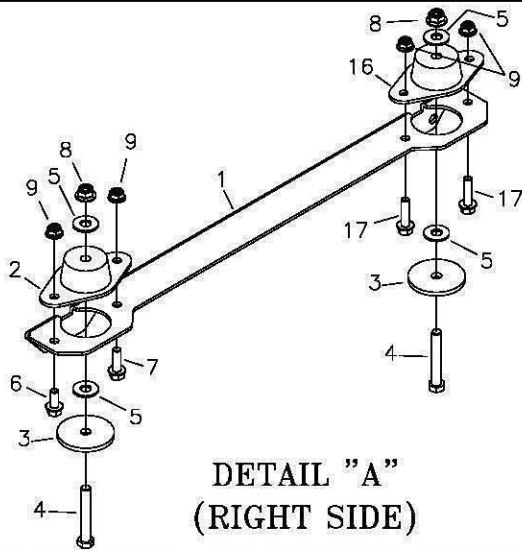
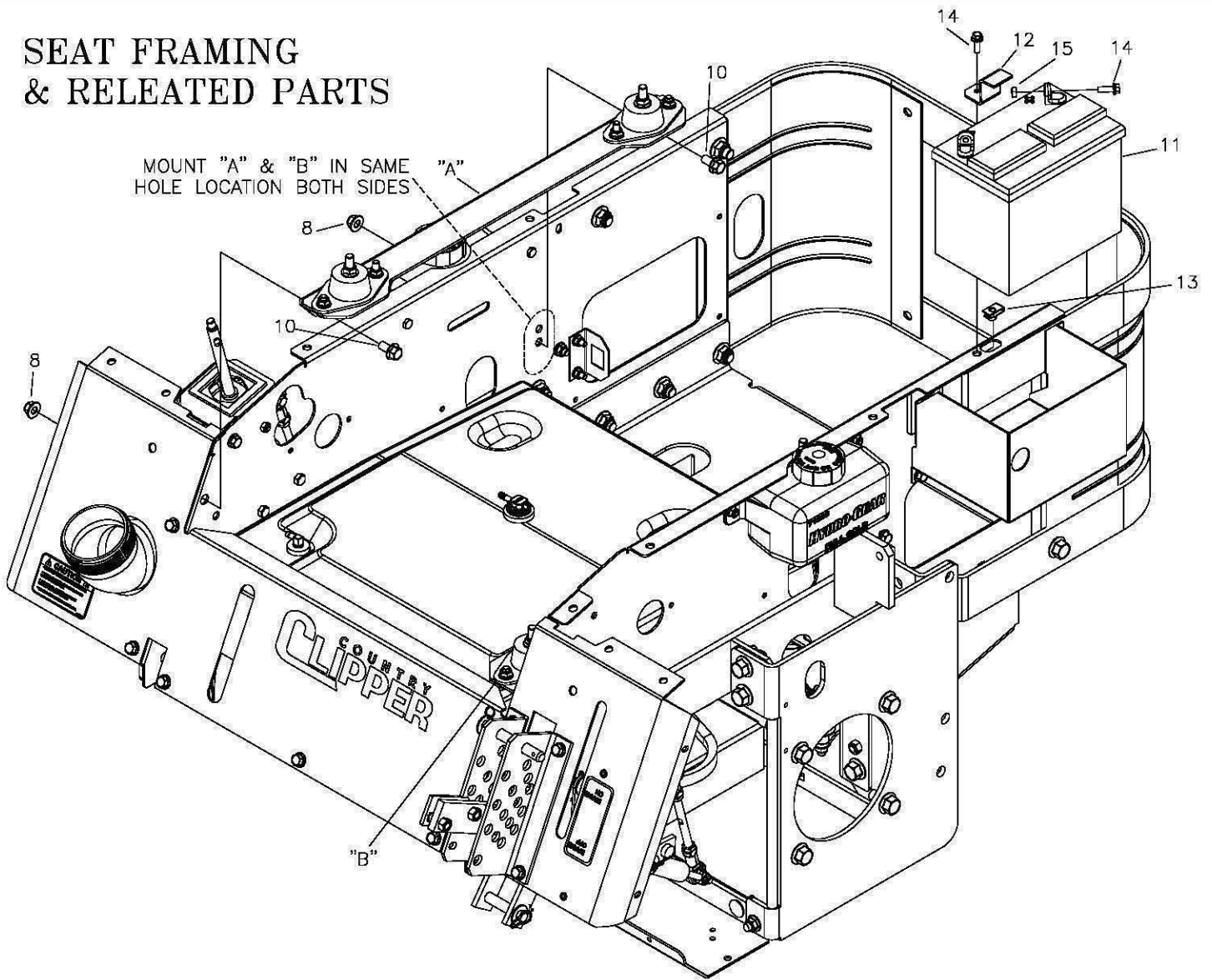

**DETAIL "A"
(RIGHT SIDE)**

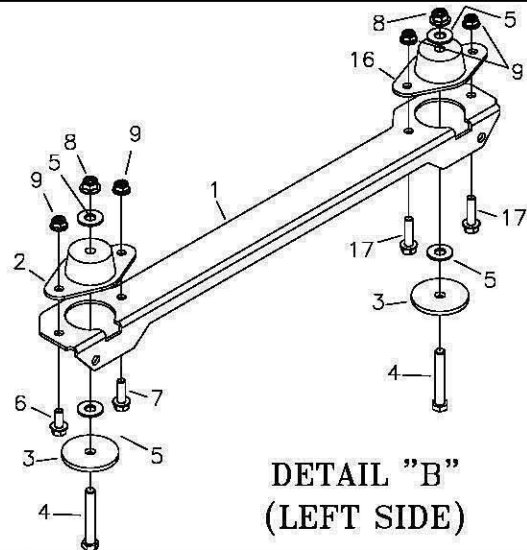

**DETAIL "B"
(LEFT SIDE)**

ITEM	PART #	QTY.	DESCRIPTION	ITEM	PART #	QTY.	DESCRIPTION
1	709-020P	2	SEAT MOUNT ANGLE	10	F-2124	4	FHCS, 3/8-16 x 3/4", YZ, GR5
2	H-2734	2	ISOLATOR, VIBRATION	11	E-6271	1	12 VOLT BATTERY, YSP 40 AMP
3	F-2102	4	WASHER .406 I.D.x2.25 O.D.x7GA	12	709-097P	1	BATTERY HOLD DOWN
4	F-1542	4	CAPSCREW, 3/8-16 X 2 3/4	13	F-1858	1	1/4-20 "U"-NUT
5	F-1009-03	8	3/8" FLAT WASHER	14	F-2162	3	FHCS, 1/4-20 x 3/4", YZ, GR5
6	F-2120	2	FHCS, 5/16-18 x 3/4", YZ, GR5	15	F-1158	2	1/4-20 STOVER NUT
7	F-2148	6	FHCS, 5/16-18 x 1", YZ, GR5	16	H-2830	2	ISOLATOR, VIBRATION
8	F-2151	4	NUT, 3/8-16 NYLOC, FLANGED	17	F-2122	4	FHCS, 5/16-18x1-1/4", YZ, GR5
9	F-2063	8	NUT, 5/16-18 NYLOC, FLANGED				

SEAT FRAMING & RELEATED PARTS (CON'T)

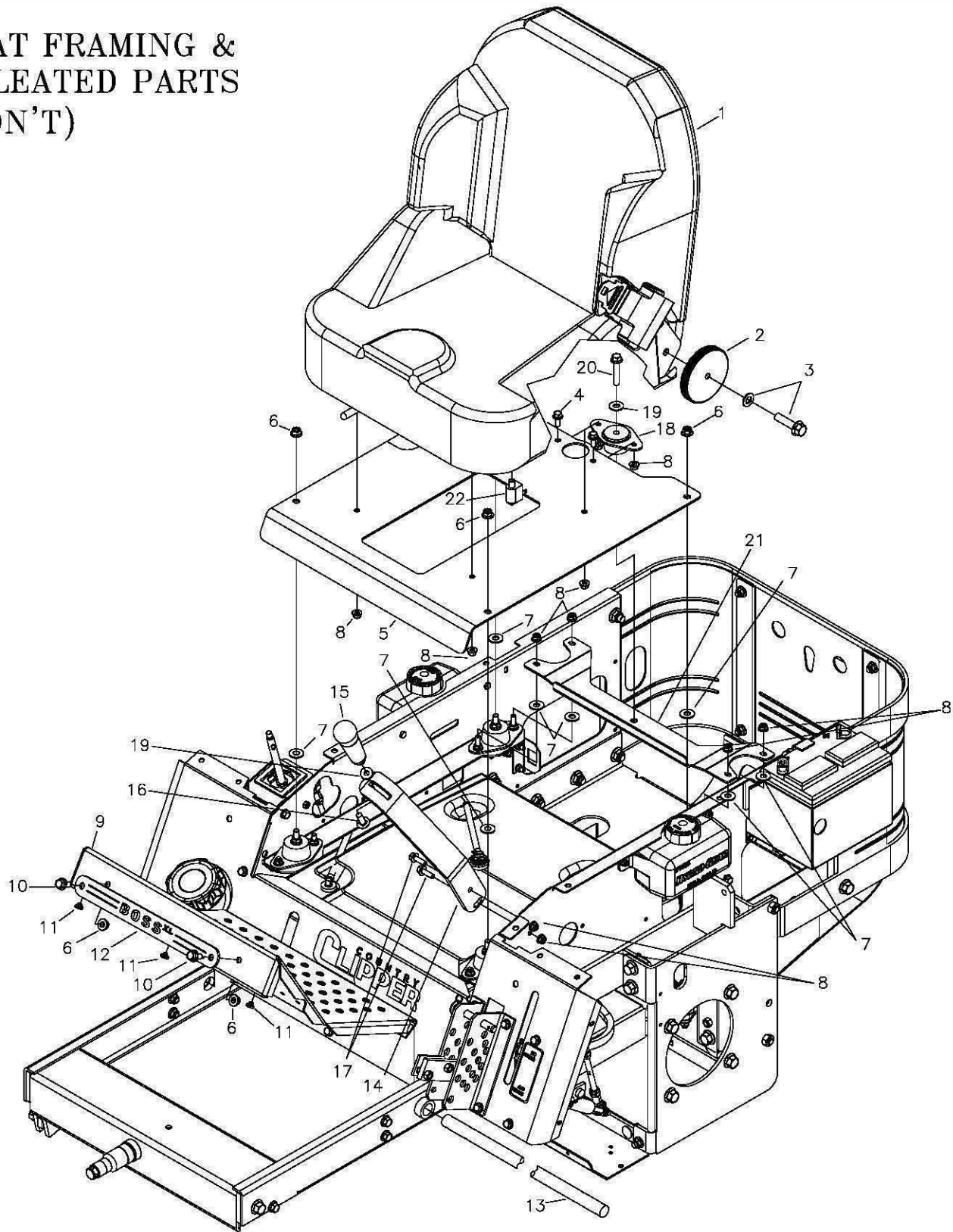

ITEM	PART #	QTY.	DESCRIPTION	ITEM	PART #	QTY.	DESCRIPTION
1	H-2788	1	SEAT	12	H-2912	1	PLACARD, BOSS XL
-	H-2916	1	COVER FOR SEAT H-2788	13	620-051P	1	LIFT BAR
2	709-147P	1	SEAT RECLINE KNOB	14	709-107P	1	BAR, SECURITY HANDLE MOUNT
3	H-2827	1	RECLINER HARDWARE KIT	15	H-2764	1	HANDLE, JOYSTICK
4	F-2120	1	FHCS, 5/16-18 x 3/4", YZ, GR5	16	F-1274	1	CARRIAGE BOLT, 3/8-16 x 1"
5	709-021P	1	SEAT PAN	17	F-2148	1	FHCS, 5/16-18 x 1", YZ, GR5
6	F-2151	6	NUT, 3/8-16 NYLOC, FLANGED	18	H-2830	1	ISOLATOR, VIBRATION
7	F-1009-02	8	5/16" FLAT WASHER	19	F-1009-03	1	3/8" FLAT WASHER
8	F-2063	12	NUT, 5/16-18 NYLOC, FLANGED	20	F-2126	1	FHCS, 3/8-16 x 2", YZ, GR5
9	642-044P	1	FOOT DECK	21	709-160P	1	CHANNEL, REAR SEAT PAN
10	F-2124	2	FHCS, 3/8-16 x 3/4", YZ, GR5	22	E-6580	1	SEAT SWITCH
11	H-2461	3	RUBBER BUMPER				

R.O.P.S. ASSEMBLY & RELATED PARTS {H-2914}

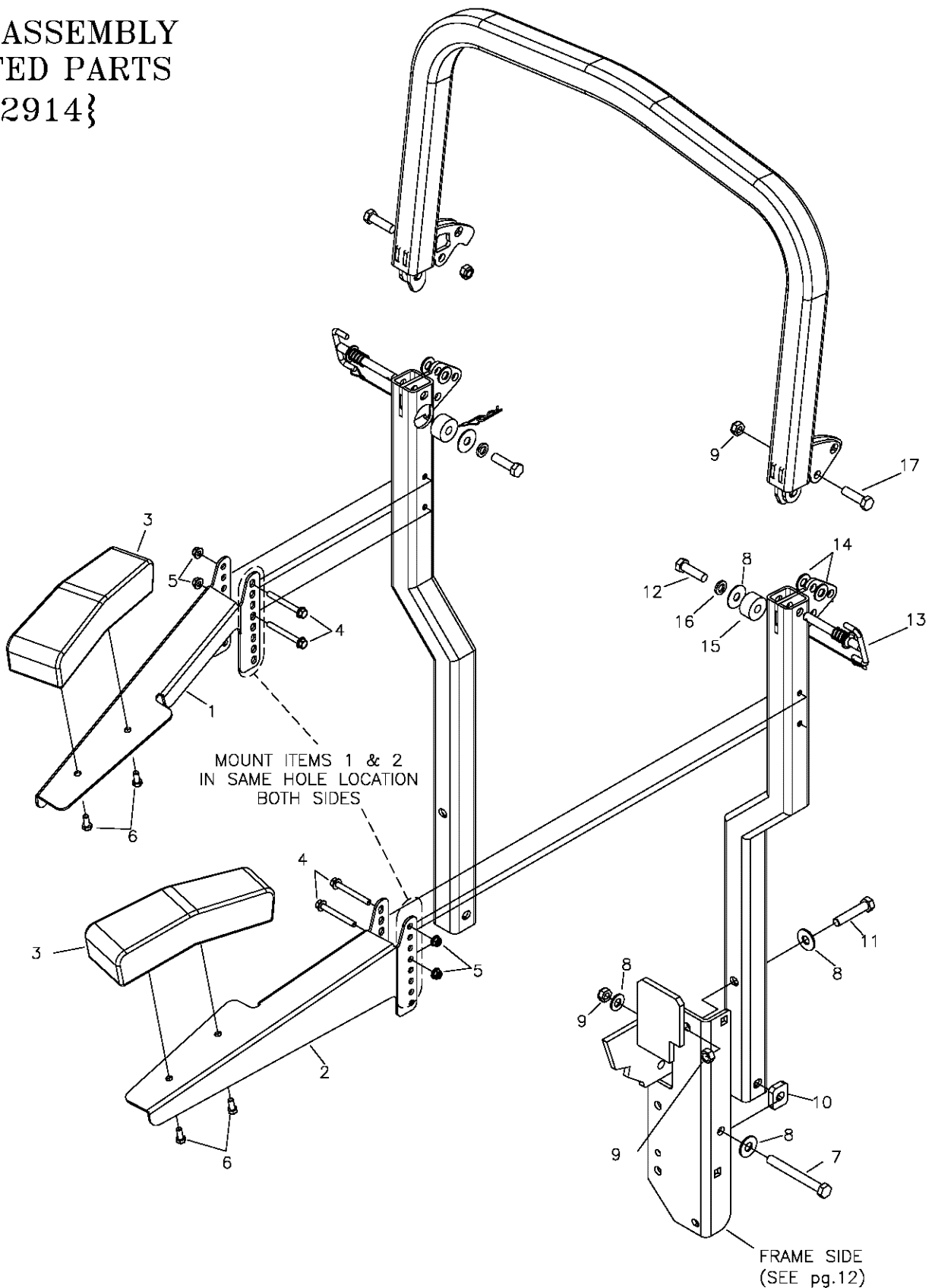

ITEM	PART #	QTY.	DESCRIPTION	ITEM	PART #	QTY.	DESCRIPTION
1	709-178P	1	ARM REST, RH	10	H-2826	2	PLATE, LOWER SPACER
2	709-179P	1	ARM REST, LH	11	F-2168	2	HHCS, 1/2-13 X 3", GR.5
3	H-2799	2	PAD, ARM REST	12	F-2211	2	HHCS, 1/2-13 X 1.75", GR.5
4	F-2153	4	FHCS, 5/16-18 X 2-3/4", YZ, GR.5	13	F-2208	2	PULL PIN ASS'Y, Ø1/2 T-HANDLE
5	F-2063	4	NUT, 5/16-18 NYLOC, FLANGED	14	F-2213	4	FW, Ø1/2 SAE
6	F-2120	4	FHCS, 5/16-18 X 3/4", YZ, GR.5	15	F-2209	2	POLYURETHANE CYLINDER
7	F-2167	2	HHCS, 1/2-13 X 3-1/2", GR.5	16	F-2210	2	LW, Ø1/2
8	F-2170	8	FW, Ø1/2	17	F-2212	2	HHCS, 1/2-13 X 2.00", GR.5
9	F-2090	6	TOP LOCK NUT, 1/2-13 GR.C				

FUEL TANK ASSEMBLY H-2726

(ALL PARTS EXCEPT #11)

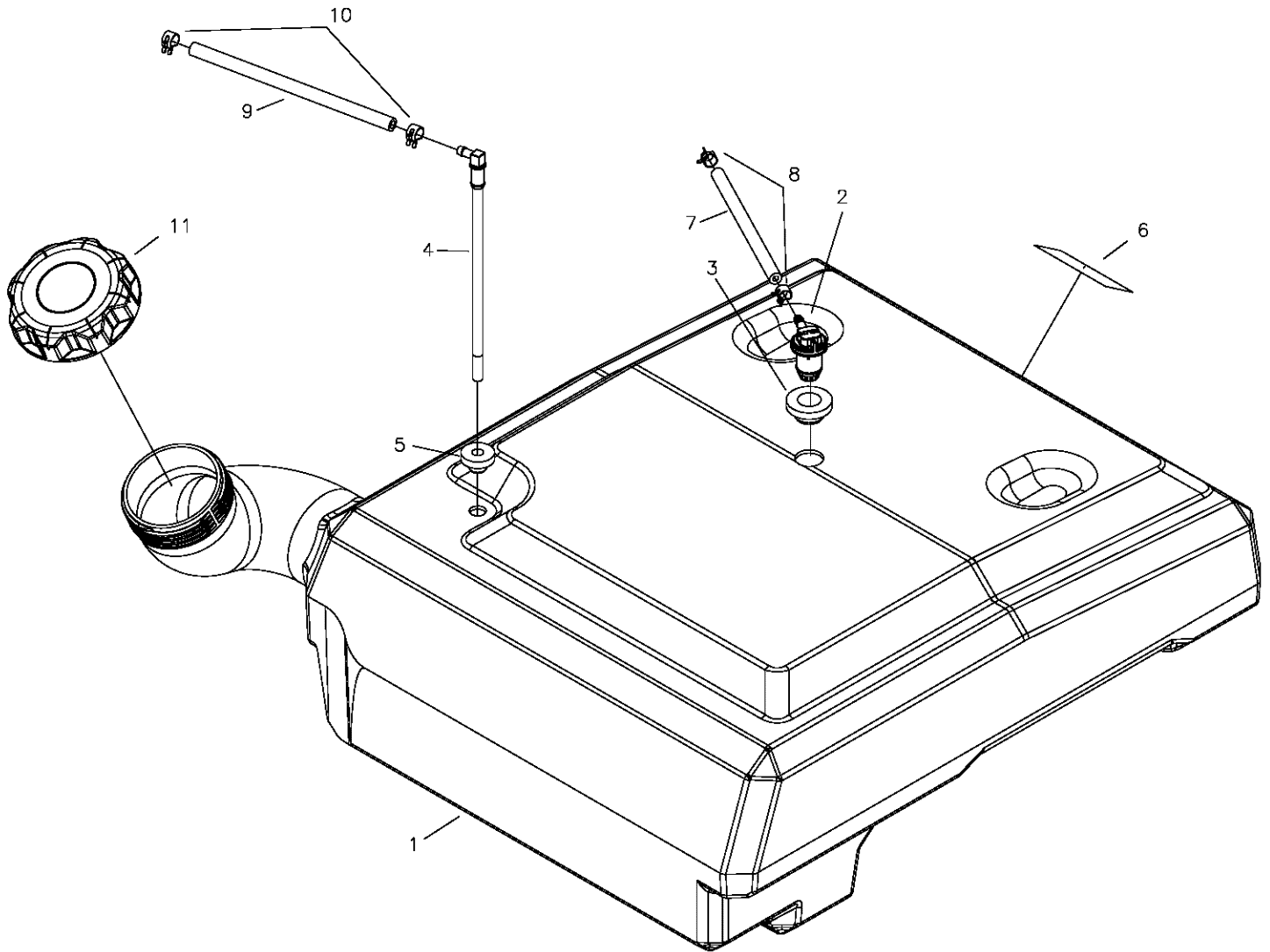

ITEM	PART #	QTY.	DESCRIPTION	ITEM	PART #	QTY.	DESCRIPTION
1	-----	1	FUEL TANK, ASS'Y	7	H-2697	4.0ft	HOSE, FUEL, .188" I.D.x.406" O.D.
2	H-2831	1	KELCH REMOTE VENT	8	H-2698	2	CLAMP, .406" O.D. FUEL LINE
3	H-2679	1	KELCH REMOTE VENT GROMMET	9	H-1648	4.0ft	HOSE, FUEL, 1/4" I.D.x1/2" O.D.
4	H-2741	1	GROMMET, PICK UP TUBE	10	H-1687	2	CLAMP, 1/2" O.D. FUEL LINE
5	H-2742	1	PICK UP TUBE	11	H-2743	1	RATCHET CAP w/TETHER, 3.5 DIA
6	P-12922	1	CARB/EPA LABEL				

JOYSTICK & RELATED PARTS (RIGHT SIDE)

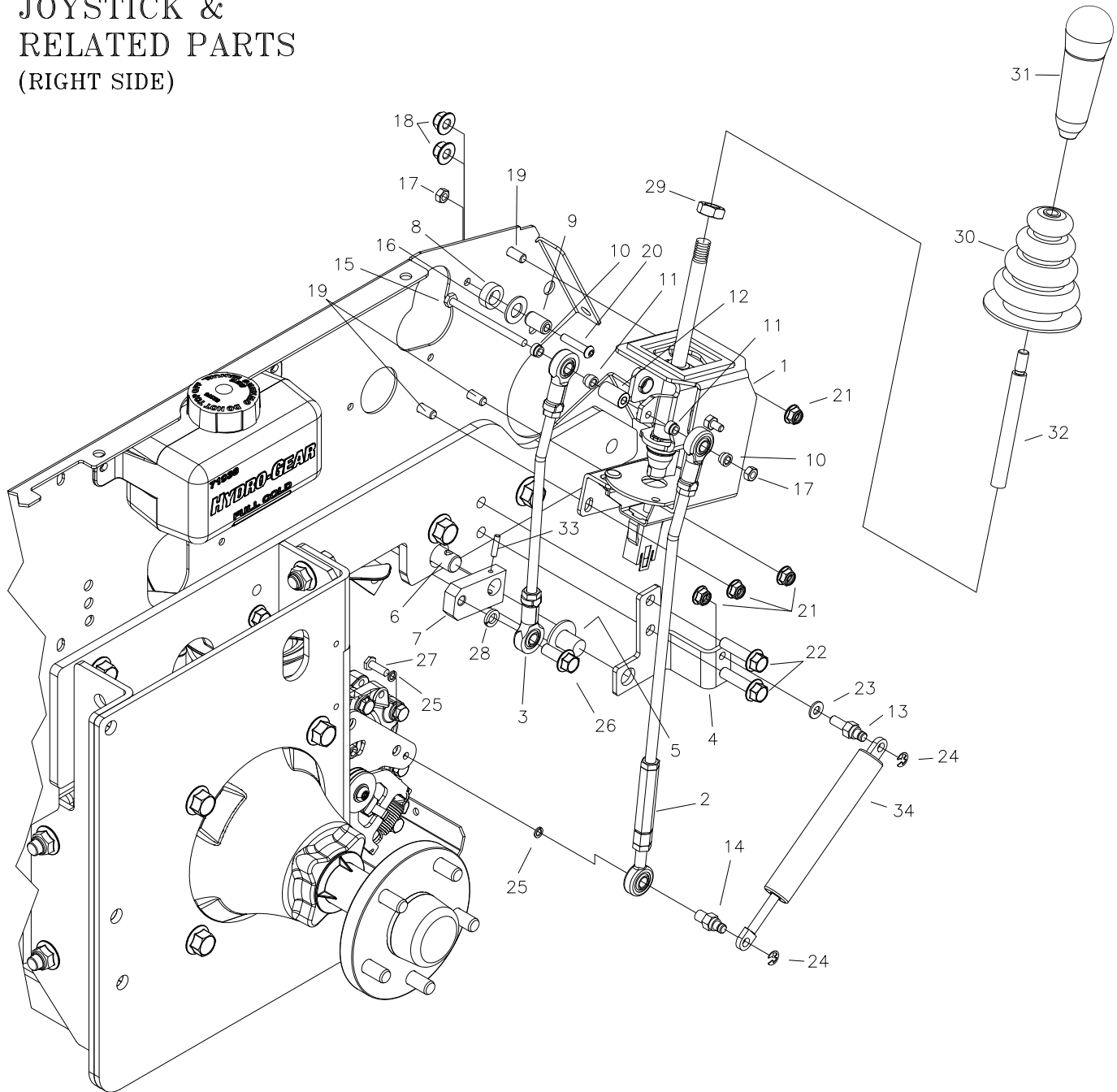

ITEM	PART #	QTY.	DESCRIPTION	ITEM	PART #	QTY.	DESCRIPTION
1	625-152A	1	JOYSTICK ASSEMBLY	18	F-2151	2	NUT, 3/8-16 NYLOC, FLANGED
2	709-131P	1	LINKAGE, OUTER, JS	19	F-2120	3	FHCS, 5/16-18 x 3/4", YZ, GR5
3	709-132P	1	LINKAGE, INNER, JS	20	F-2103	1	BUTTON SHCS, 1/4-20 x 1", CZ
4	709-083P	1	BRACKET-ANCHOR, DAMPER	21	F-2063	4	NUT, 5/16-18 NYLOC, FLANGED
5	709-116W	1	BRAKE ROD WLDT	22	F-2147	2	FHCS, 3/8-16x1-1/2", YZ, GR5
6	709-213P	1	HYDRO SHIFT ROD	23	F-1009-01	1	1/4" FLAT WASHER
7	700-151P	1	ARM, SWIVEL, S/A	24	F-1610	2	E-RING FOR 1/4" SHAFT
8	625-126P	1	SPACER JOYSTICK, PANEL	25	F-1019-01	2	1/4" LOCKWASHER
9	625-119P	1	PIN, PIVOT, JS, LONG	26	F-2141	1	FHCS, 3/8-16 x 1", YZ, GR5
10	625-116P	2	BUSHING, .375 ROD END, SHORT	27	F-1015-03	1	1/4-20 x 3/4", CAPSCREW
11	625-107P	2	BUSHING, .375 ROD END, LONG	28	F-1019-03	1	3/8" LOCKWASHER
12	625-100P	1	TUBE, PIVOT, JOYSTICK	29	F-1462	1	1/2-20 HEX JAM NUT
13	638-028P	1	DAMPER BOLT	30	H-1991	1	BOOT
14	663-051P	1	DAMPER STUD	31	H-2764	1	HANDLE, JOYSTICK
15	F-1020-01	1	1/4-20 x 3-1/2" CAPSCREW	32	709-167P	1	EXTENSION, JOYSTICK
16	F-1521	1	1/2" WASHER, CUSTOM	33	F-2206	1	SHCS, 12-24 x 1-1/4, ZINC
17	F-1005-01	2	1/4-20 LOCK NUT	34	H-2467	1	DUAL ACTION DAMPER

**JOYSTICK &
RELATED PARTS
(LEFT SIDE)**

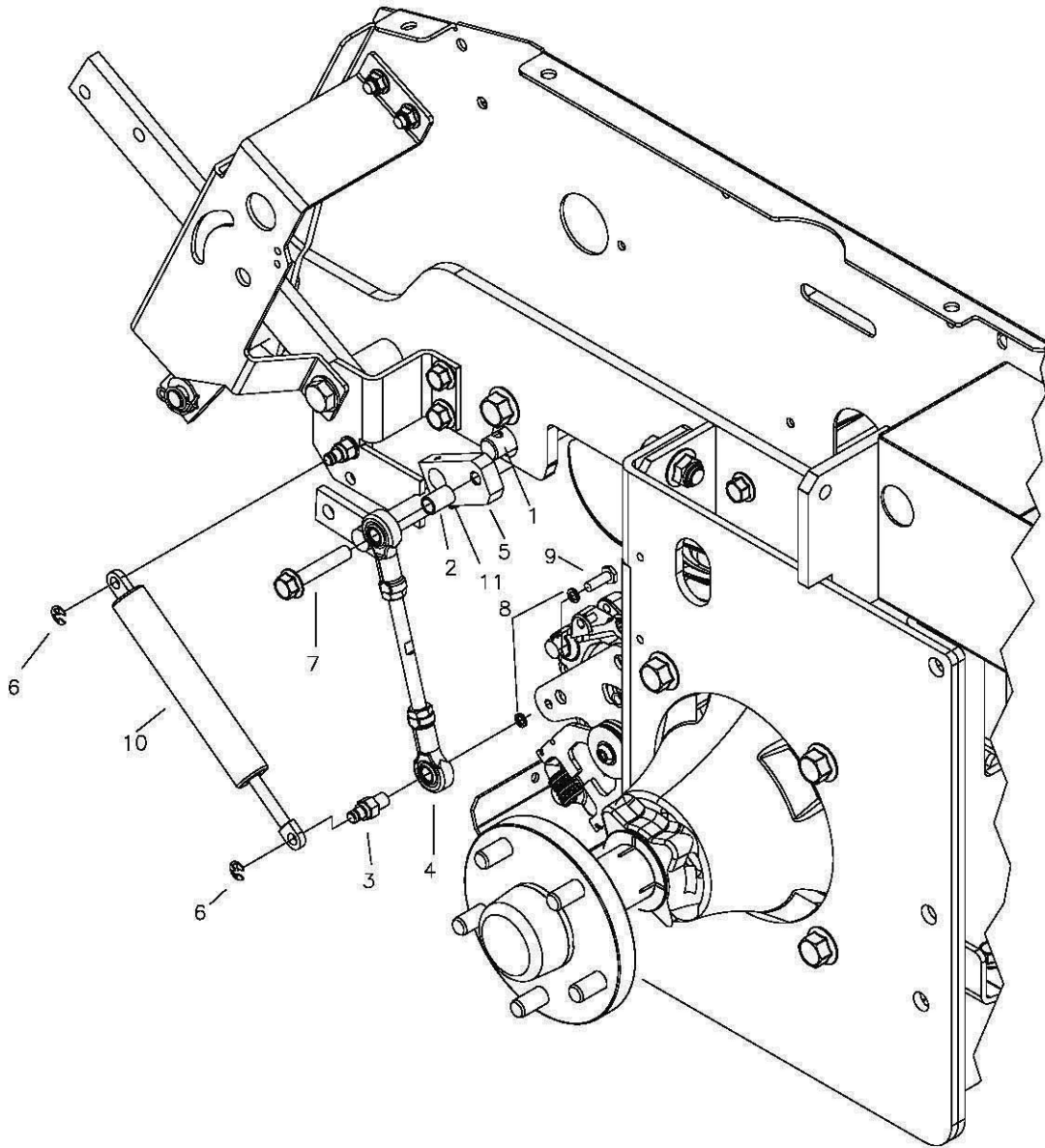

ITEM	PART #	QTY.	DESCRIPTION	ITEM	PART #	QTY.	DESCRIPTION
1	709-213P	1	HYDRO SHIFT ROD	7	F-2126	1	FHCS, 3/8-16 x 2", YZ, GR5
2	707-073P	1	STAND-OFF, LINKAGE MOUNT	8	F-1019-01	2	1/4" LOCKWASHER
3	663-051P	1	DAMPER STUD	9	F-1015-03	1	1/4-20 x 3/4" CAPSCREW
4	659-127P	1	LINKAGE ROD	10	H-2467	1	DUAL ACTION DAMPER
5	700-151P	1	ARM, SWIVEL, S/A	11	F-2206	1	SHCS, 12-24 X 1-1/4, ZINC
6	F-1610	2	E-RING FOR 1/4" SHAFT				

JOYSTICK ASSEMBLY 625-152A

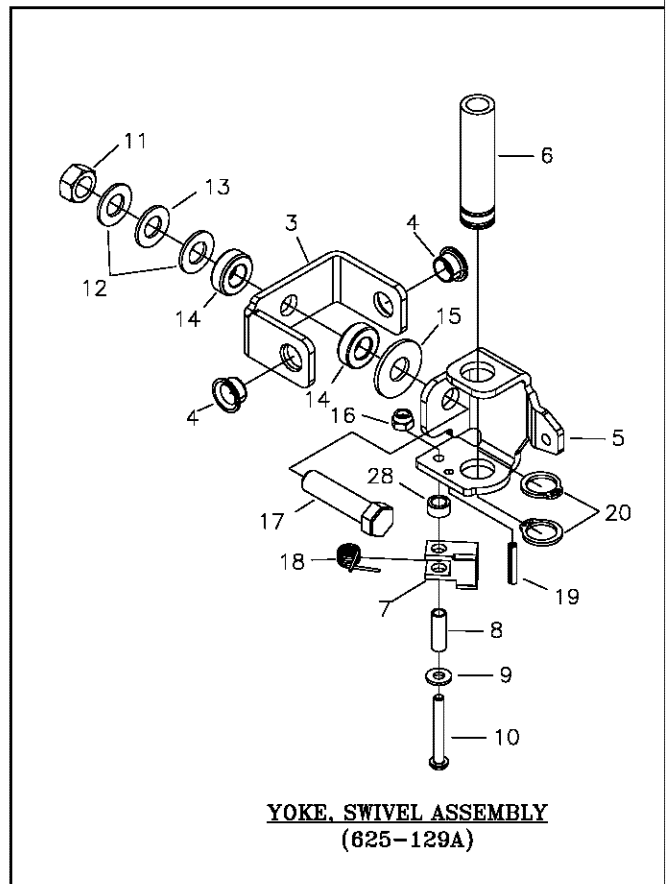
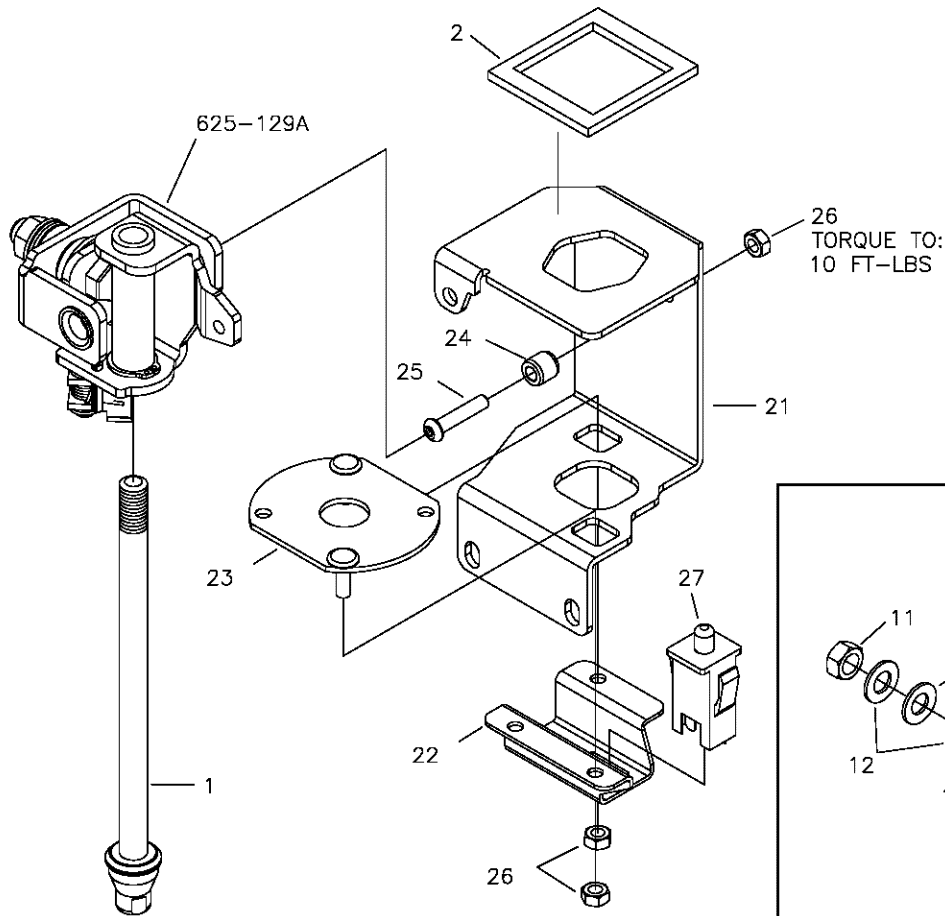

**YOKE, SWIVEL ASSEMBLY
(625-129A)**

ITEM	PART #	QTY.	DESCRIPTION	ITEM	PART #	QTY.	DESCRIPTION
1	709-169A	1	ROD ASSEMBLY	15	F-1009-05	1	1/2" FLAT WASHER
2	H-1947	1	GASKET, FOAM, JOYSTICK	16	F-2137	1	NUT, #12-24, NYLOCK
3	625-097P	1	PIVOT, JOYSTICK (PART OF 625-128A)	17	F-1293	1	1/2-13 x 2" CAPSCREW
4	D-3784	2	BUSHING, FLANGED (PART OF 625-128A)	18	H-2710	1	SPRING, DETENT, JOYSTICK
5	625-096P	1	YOKE, SWIVEL, JOYSTICK	19	F-1503	1	3/16 x 1" SPIRAL PIN
6	625-099P	1	TUBE, GUIDE, CONTROL ROD	20	H-2705	2	RING, DETENT, .75 EXT.
7	625-103P	1	TAB, CAM DETENT	21	625-154P	1	HOUSING, JOYSTICK
8	625-124P	1	TUBE-SPACER, DETENT CAM	22	659-285P	1	MOUNT, SWITCH
9	F-2136	1	WASHER, FLAT, #12 PLAIN	23	625-127W	1	NEUTRAL PLATE, WLDT
10	F-2135	1	SCR, PANHD, PHLPS, #12-24x1-3/4"	24	625-106P	1	PIN, PIVOT, JOYSTICK
11	F-1005-05	1	1/2-13 STOVER NUT	25	F-2103	1	BUTTON SHCS, 1/4-20 x 1", CZ
12	F-1521	2	1/2" WASHER, CUSTOM	26	F-1005-01	3	1/4-20 LOCK NUT
13	H-2704	1	SPRING, BELLEVILLE, .50x1x.073	27	E-6474	1	SWITCH, SNAP MOUNT
14	D-3857	2	THRUST BEARING	28	625-125P	1	SPACER, CAM DETENT

TWINSTICK & RELATED PARTS

(RIGHT SIDE SHOWN, LEFTHAND OPPOSITE)

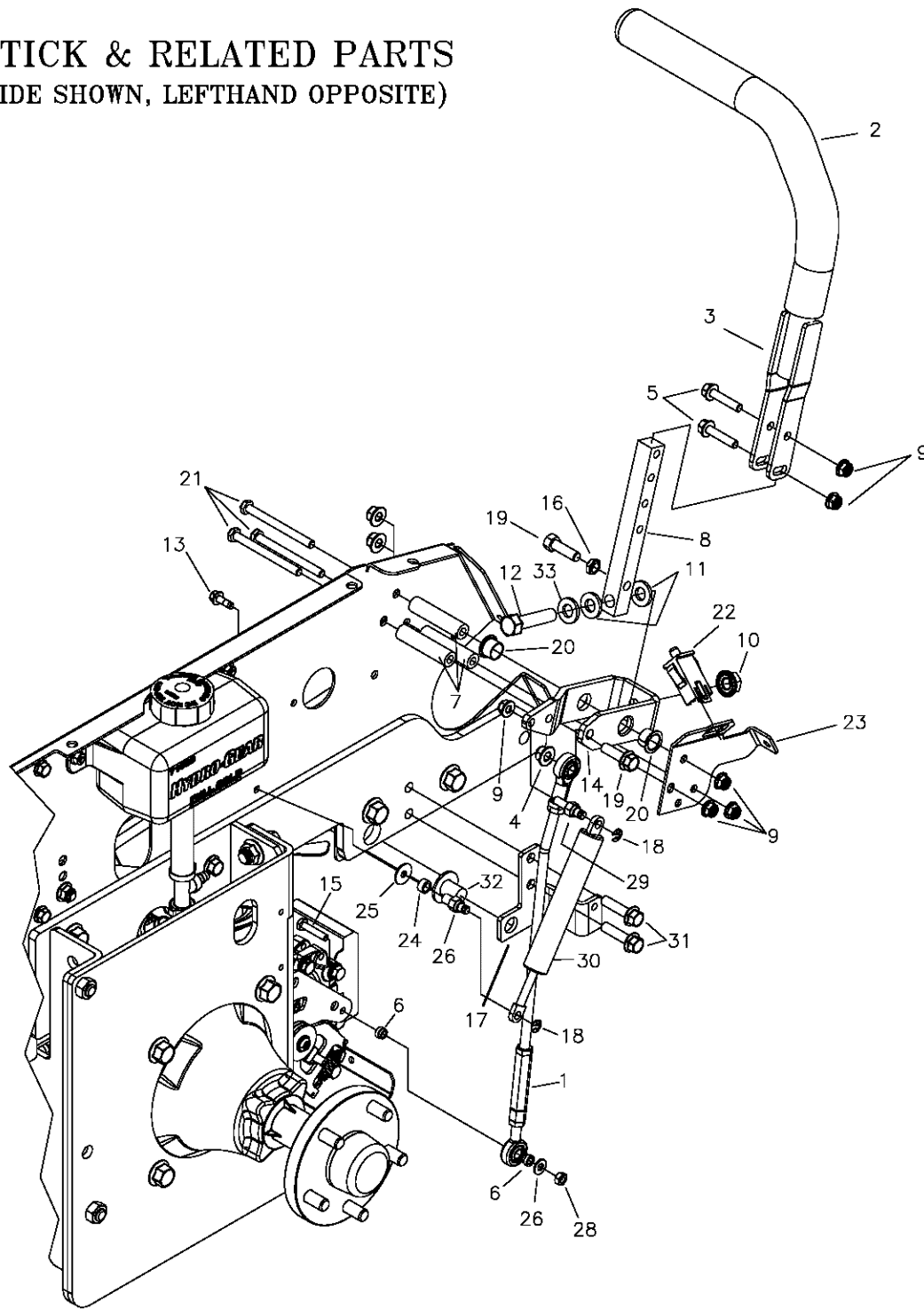

ITEM	PART #	QTY.	DESCRIPTION	ITEM	PART #	QTY.	DESCRIPTION
1	H-2794	1	LINKAGE, OUTER	18	F-1610	2	E-RING FOR 1/4" SHAFT
2	H-2739	1	GRIP, 15", CLOSED END	19	F-1307	2	3/8-16 X 1 1/4" CAPSCREW
3	659-364W	1	DUAL LEVER CONTROL	20	D-3730	2	FLANGED BUSHING 5/8" BORE
4	F-2151	1	NUT, 3/8-16 NYLOC, FLANGED	21	F-2058	3	5/16-18 x 3 1/2" CAPSCREW
5	F-2129	2	FHCS, 5/16-18x1-1/2" w/PATCH	22	E-6474	1	SWITCH, SNAP MOUNT
6	625-116P	2	BUSHING, .375 ROD END, SHORT	23	647-242P	1	MOUNTING BRACKET (RH)
7	659-252P	3	TUBE SPACER	—	647-243P	1	MOUNTING BRACKET (LH)
8	659-365P	1	LOWER SHIFT BLOCK	24	625-125P	1	SPACER, CAM DETENT
9	F-2063	6	5/16-18 NYLOC NUT	25	F-2097	1	1/4" FENDER WASHER
10	F-2060	2	1/2-13 NUT, FLANGE LOCK	26	663-051P	1	DAMPER STUD, FEMALE
11	606-151P	2	WASHER, NYLON 1/2 ID x 1/8"	27	638-029P	1	DAMPER BOLT, 1/4-20
12	F-1293	1	HHCS, 1/2-13 x 2" GR5	28	F-1005-01	1	1/4-20, LOCK NUT
13	F-2119	1	FHCS, 1/4-20x3/4", YZ, GR5	29	638-028P	1	DAMPER BOLT, 5/16-18 x 3/4"
14	659-243P	1	SHIFTING YOKE	30	H-2843	1	DUAL ACTION DAMPER
15	F-2182	1	FHCS, 1/4-20x1-1/4", YZ, GR5	31	F-2147	2	FHCS, 3/8-16x1-1/2", YZ, GR5
16	F-1486	2	3/8-16 JAM NUT	32	709-116W	1	BRAKE ROD, WLDT
17	709-083P	1	BRACKET-ANCHOR, DAMPER	33	F-1521	1	WASHER

PARKING BRAKE & RELATED PARTS

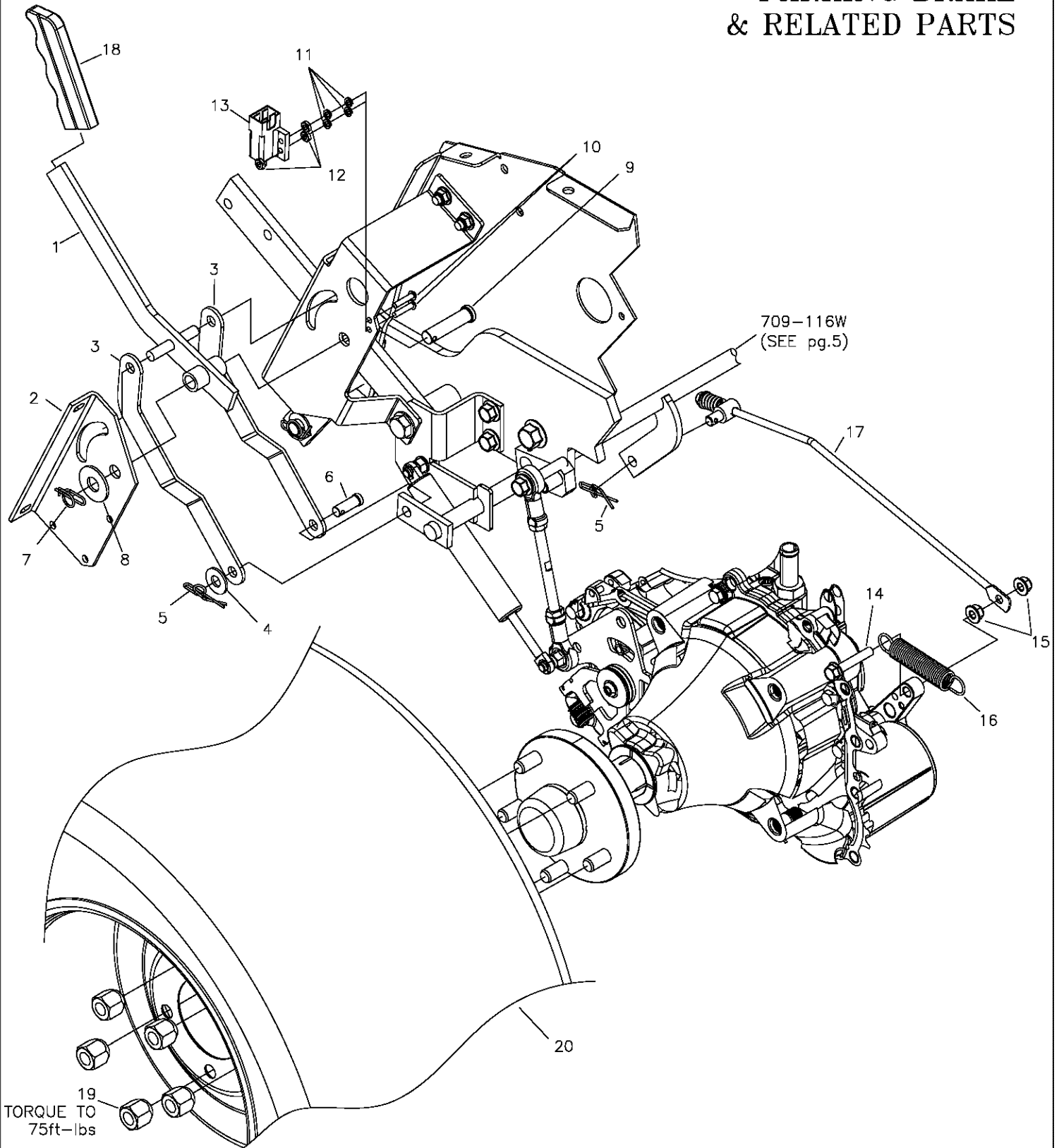

ITEM	PART #	QTY.	DESCRIPTION	ITEM	PART #	QTY.	DESCRIPTION
1	709-180W	1	BRAKE HANDLE WLDT	11	F-1112	4	LOCKWASHER, #10 SPRING
2	709-183P	1	BRAKE LEVER MOUNTING ANGLE	12	F-1448	3	10-32 NYLOC, NUT
3	709-114P	2	LINK, BRAKE	13	E-6297	1	BRAKE SWITCH
4	F-1009-02	1	5/16" FLAT WASHER	14	F-2123	2	FHCS, 5/16-18x1-3/4", YZ, GR5
5	F-1492	1	5/16-3/8 RUE RING	15	F-2063	4	NUT, 5/16-18 NYLOC, FLANGED
6	F-1691	1	3/8" x 1" CLEVIS PIN	16	H-1635	2	SPRING, EXT, 3/4"ODx4"OAL
7	H-2239	1	1/2" RUE RING	17	709-135P	2	BRAKE LINK ROD ASEMBLY
8	F-1521	1	1/2" WASHER, CUSTOM	18	H-1926	2	BRAKE LINK ROD ASEMBLY
9	F-1897	1	1/2" x 2-1/4" CLEVIS PIN	19	F-1499	5	1/2-20 LUG NUT
10	F-1022-28	2	10-32 x 7/8" MACHINE SCREW	20	D-3894	1	TIRE, 26x14.00-12

TRANSMISSION & RELATED PARTS

(RIGHT HAND SHOWN, LEFT HAND OPPOSITE)

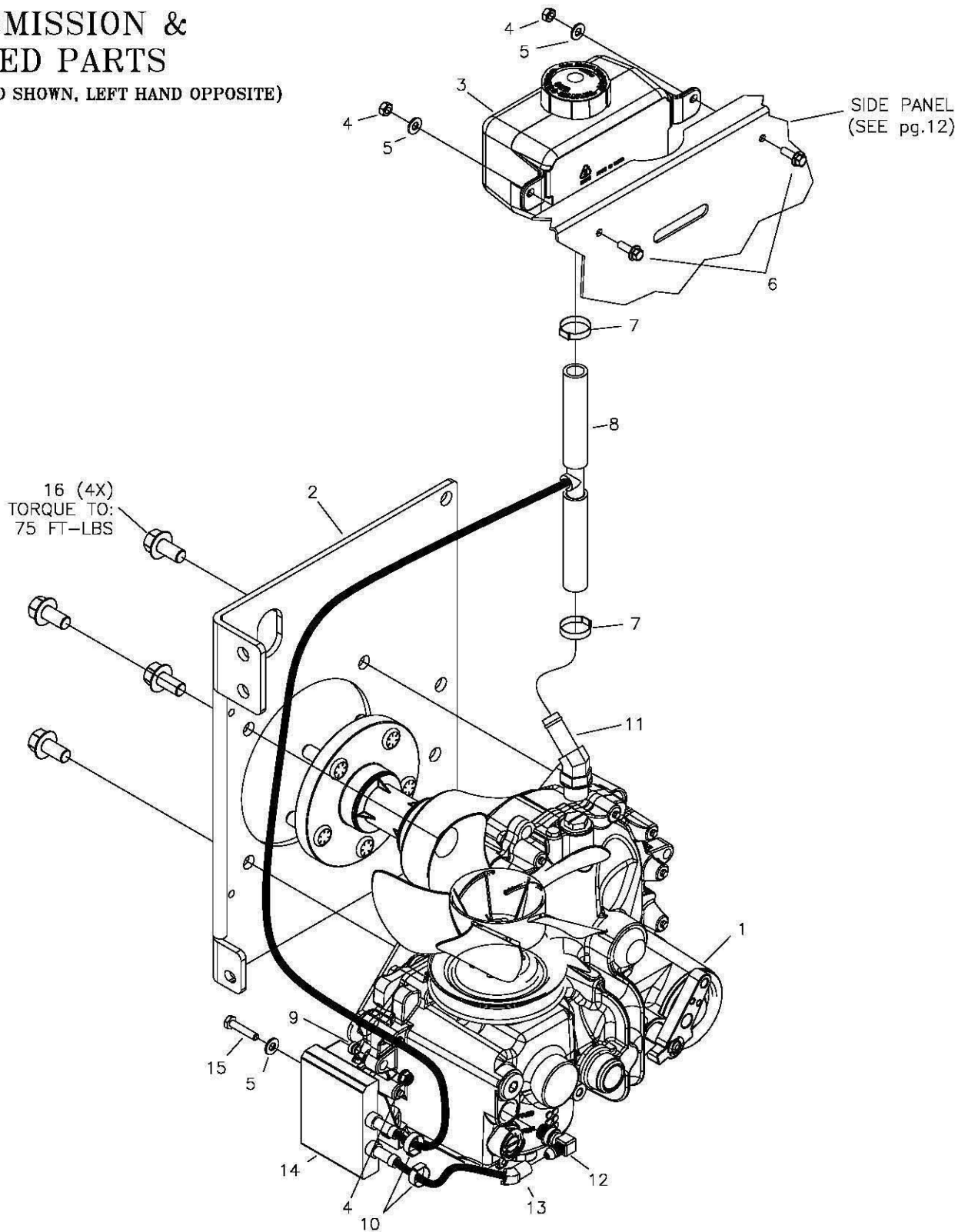

ITEM	PART #	QTY.	DESCRIPTION	ITEM	PART #	QTY.	DESCRIPTION
1	D-3875-01	1	TRANSMISSION, ZT5400, LH	9	625-116P	2	SPACER
-	D-3875-02	1	TRANSMISSION, ZT5400, RH	10	H-2840	2	HOSE CLAMP, 11/16"
2	709-095W	1	HYDRO MOUNT WLDT, LH	11	H-2779	2	FITTING, 45 DEG., HOSE BARB
-	709-096W	1	HYDRO MOUNT WLDT, RH	12	H-2331	2	9/16", 90 DEG. EL
3	H-2735	2	TANK, HYDRO EXP., HYDROGEAR	13	H-2857	2	HOSE ASS'Y, LOW PRESSURE, 3/8"
4	F-2132	6	NUT, 1/4-20 NYLOC, FLANGED	14	H-2780	2	COOLER, OIL, STACKED PLT, 3"x4"
5	F-1009-01	6	1/4" FLAT WASHER	15	F-1539	2	1/4-20 x 1-1/4", CAPSCREW
6	F-2162	4	FHCS, 1/4-20 x 3/4", YZ, GR5	16	F-2143	8	FHCS, 1/2-13x1", YZ, GR5
7	H-2866	2	HOSE CLAMP, 7/8"				
8	H-2855	1	HOSE ASS'Y, LOW PRESSURE, TEE, RH				
-	H-2856	1	HOSE ASS'Y, LOW PRESSURE, TEE, LH				

HYDRO IDLER & RELATED PARTS

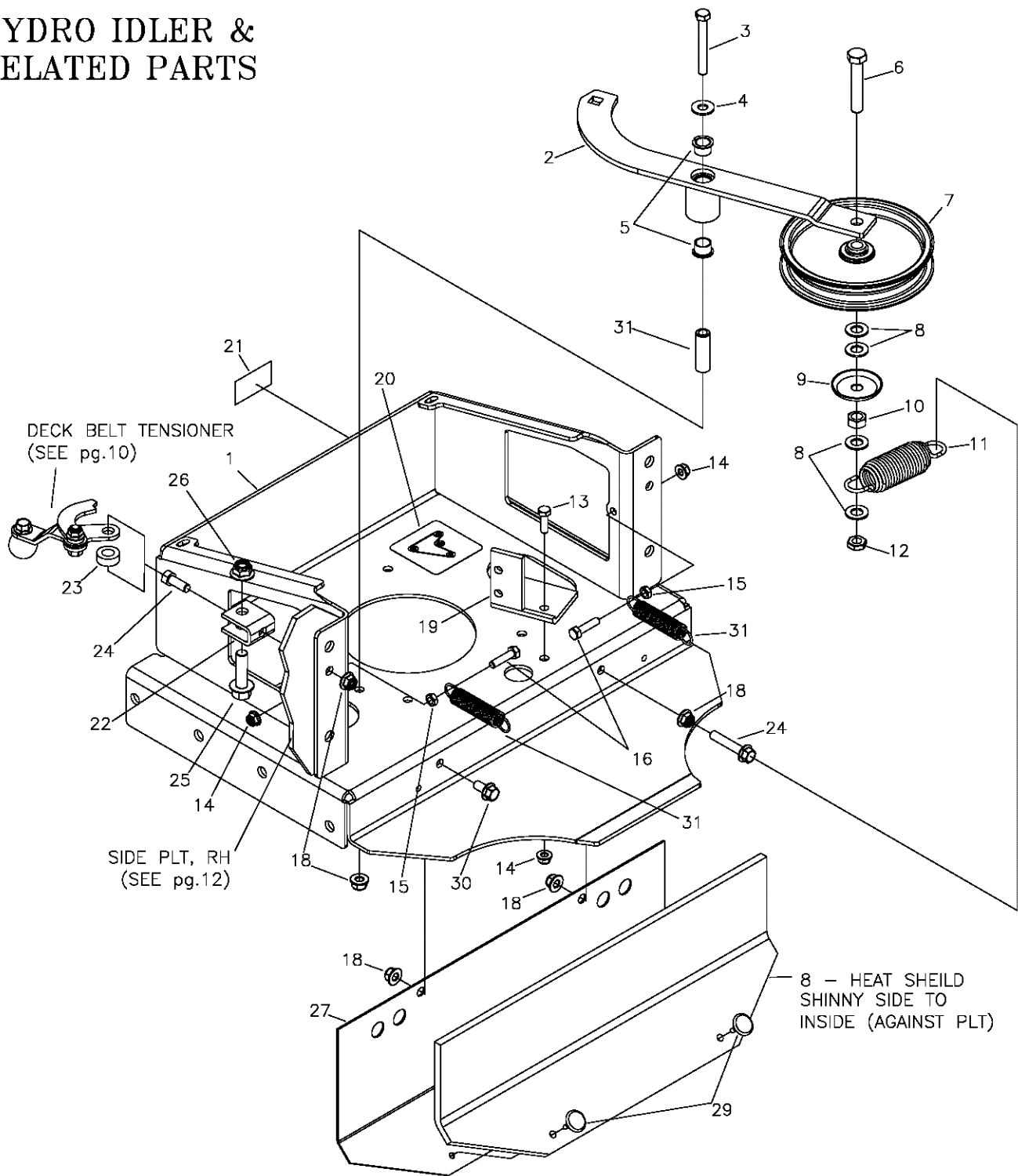

ITEM	PART #	QTY.	DESCRIPTION	ITEM	PART #	QTY.	DESCRIPTION
1	709-009W	1	MOTER MOUNT WLDT	17	F-2124	1	FHCS, 3/8-16 x 3/4", YZ, GR5
2	709-048A	1	IDLER ARM ASSEMBLY	18	F-2151	5	NUT, 3/8-16 NYLOC, FLANGED
3	F-2207	1	HHCS, 3/8-16 X 3", YZ, GR8	19	709-106P	1	CLUTCH STOP
4	F-1009-03	1	3/8" FLAT WASHER	20	P-12918	1	DECAL, HYDRO BELT ROUTING
5	D-3730	2	BUSHING, FLANGED (PART OF 709-048A)	21	P-10777	1	PATENT NUMBER DECAL
6	F-1668	1	1/2-13 x 2-3/4", CAPSCREW	22	661-015P	1	SHACKLE
7	D-3903	1	PULLEY, FLAT IDLER, 6"	23	660-038P	1	3/8" SPACER
8	F-1521	3	1/2" WASHER, CUSTOM	24	F-1307	2	3/8-16 x 1-1/4", CAPSCREW
9	620-201P	1	WASHER, BEARING CAP	25	F-2154	1	FHCS, 1/2-13x1-3/4", YZ, GR5
10	F-1005-05	1	1/2-13 STOVER NUT	26	F-2152	1	NUT, 1/2-13 NYLOC, FLANGED
11	H-2619	1	SPRING, 5"x1-1/2", TAPERED ENDS	27	709-154P	1	PLATE, FILLER, REAR
12	F-1966	1	1/2-13 THIN NYLOC NUT	28	709-159P	1	HEAT SHIELD
13	F-1015-15	1	5/16-18 x 1" CAPSCREW	29	F-2165	2	FASTENER, PUSH IN FIR TREE .25x1x1
14	F-2063	3	NUT, 5/16-18 NYLOC, FLANGED	30	H-1635	2	SPRING (SEE pg.24)
15	F-1125	2	5/16-18 NUT	31	709-077P	1	MOUNTING PIN
16	F-1015-17	2	5/16-18 x 1-1/2", CAPSCREW				

ENGINE & RELATED PARTS

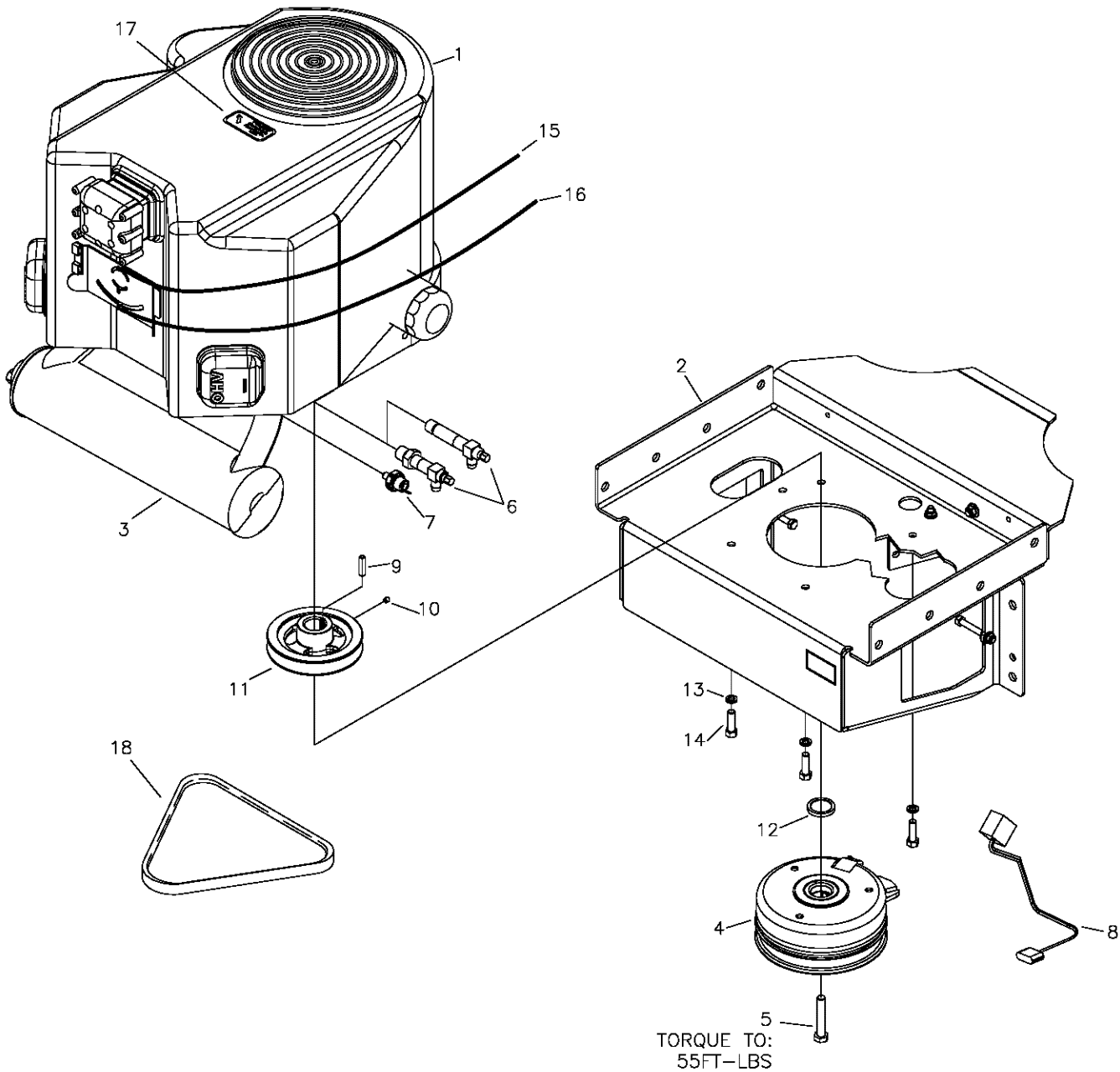

TORQUE TO:
55FT-LBS

ITEM	PART #	QTY.	DESCRIPTION	ITEM	PART #	QTY.	DESCRIPTION
1	M-5360	1	ENGINE, 35HP KAWASAKI	10	F-1228	1	1/4-20x1/4" SET SCREW NYLOC
-	M-5400	1	ENGINE, 27HP KOHLER	11	709-134P	1	PULLEY, MOTOR, 5.245 DIA
2	709-009W	1	MOTOR MOUNT WLDT	12	709-161P	1	SPACER, ENGINE PULLEY (KOHLER)
3	H-2777	1	MUFFLER, 35HP KAWASAKI	13	F-1019-03	4	3/8" LOCKWASHER
-	H-2774	1	MUFFLER, 27HP KOHLER	14	F-2125	4	HCS, 3/8-16 x 1-1/4" (KAWASAKI)
4	E-6444	1	CLUTCH, 200ft/lb (KOHLER)	-	F-2040	4	HCS, 3/8-16x1-1/2" THD FORM (KOH)
-	E-6425	1	CLUTCH, 250ft/lb (KAWASAKI)	15	H-2612	1	THROTTLE CABLE (KOHLER)
5	F-2113	1	CAPSCREW, 7/16-20x2-1/2", GR8	-	H-2611	1	THROTTLE CABLE (KAWASAKI)
6	H-2589	1	OIL DRAIN (KOHLER)	16	H-2404	1	CHOKE CABLE
-	H-2590	1	OIL DRAIN (KAWASAKI)	17	P-10077-11	1	DECAL "CLEAN DEBRIS"
7	E-6307	1	OIL PRESSURE SWITCH (KAWASAKI)	18	D-3900	1	HYDRO DRIVE BELT, B-71
8	E-6575	1	WIRE HARNES, CLUTCH EXTENSION				
9	621-113P	1	1/4"SQ x 1-1/4" KEY				

WIRE HARNESS & RELATED PARTS (JOYSTICK)

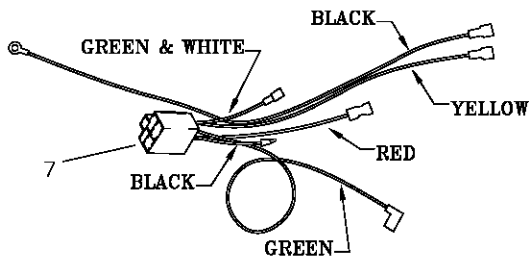
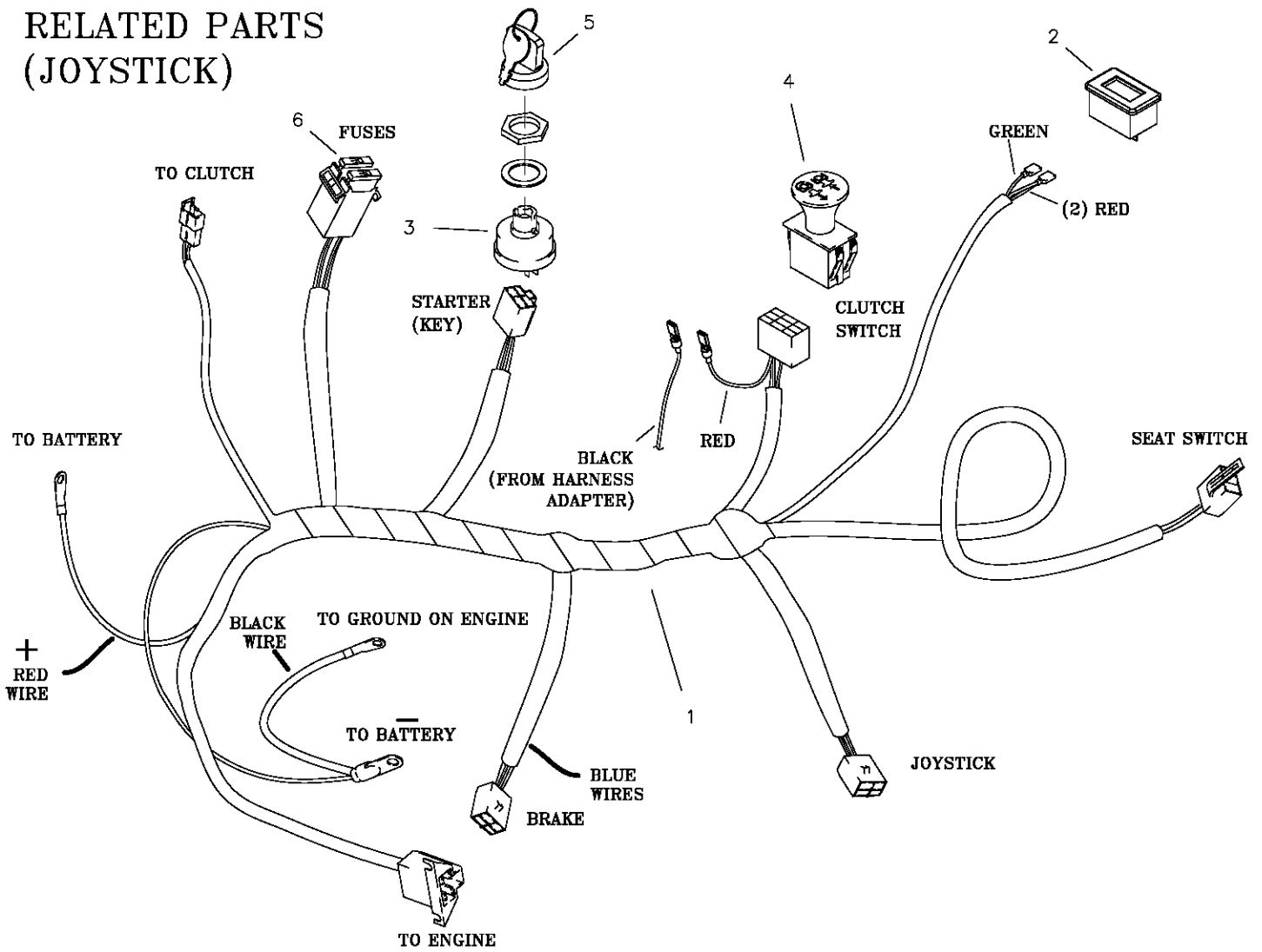

HARNESS ADAPTER
{ONLY REQ'D ON KAWASAKI ENGINES}

ITEM	PART #	QTY.	DESCRIPTION	ITEM	PART #	QTY.	DESCRIPTION
1	E-6548	1	WIRE HARNESS, JS	5	E-6445	1	KEY, SET
2	E-5878	1	HOUR METER	6	E-6207	2	FUSE, #ATC-30
3	E-5873	1	KEY SWITCH (INCLUDES #5)	7	E-6417	1	KAWASAKI HARNESS ADAPTER
4	E-6403	1	PTO SWITCH				

WIRE HARNESS & RELATED PARTS (TWINSTICK)

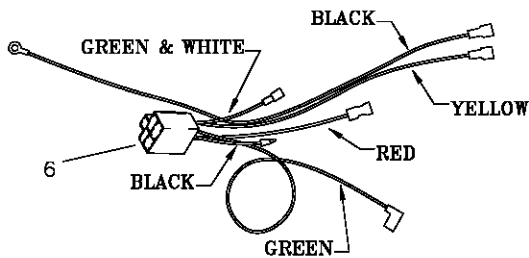
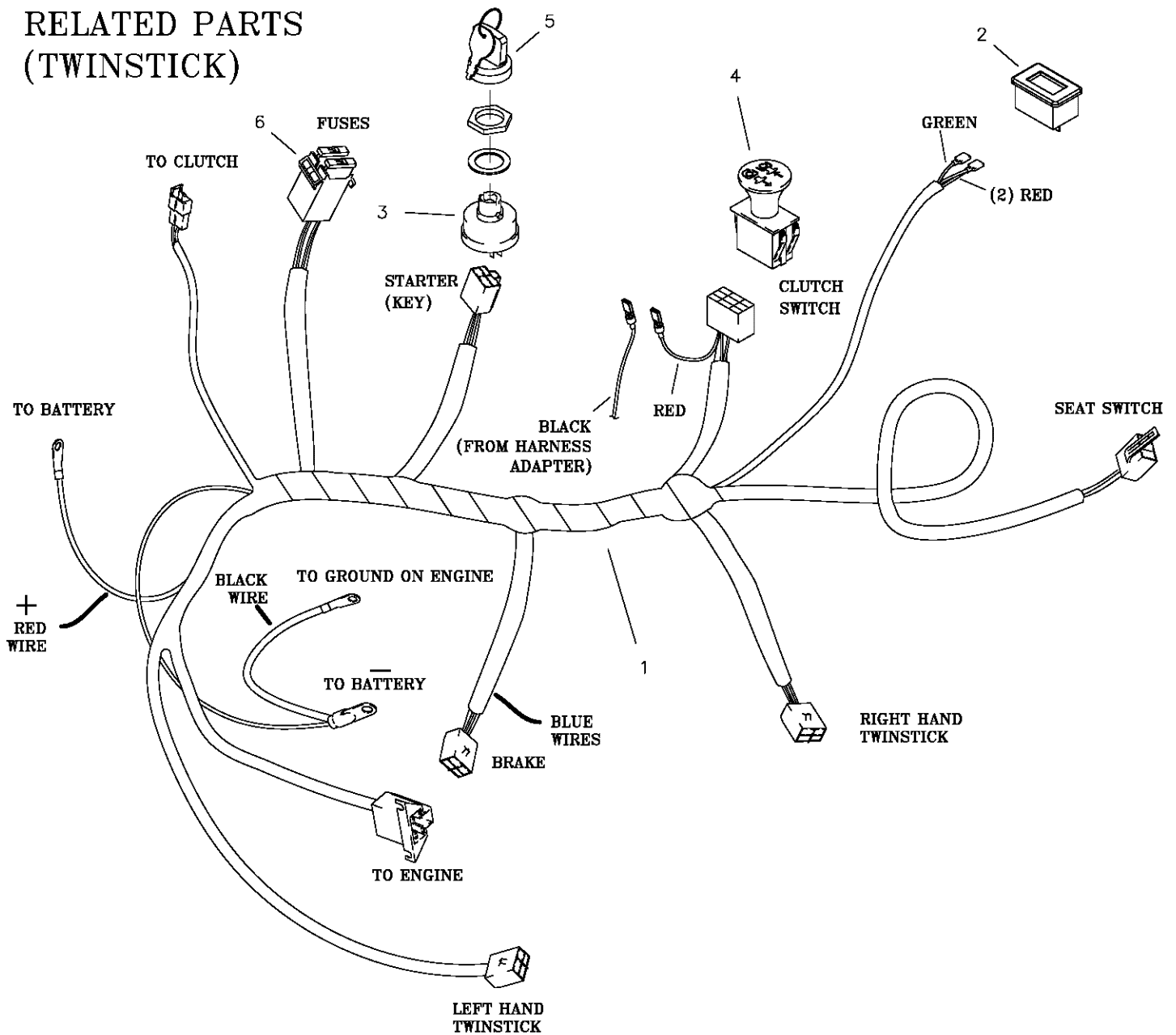

HARNESS ADAPTER
 {ONLY REQ'D ON KAWASAKI ENGINES}

ITEM	PART #	QTY.	DESCRIPTION	ITEM	PART #	QTY.	DESCRIPTION
1	E-6549	1	WIRE HARNESS, TS	5	E-6445	1	KEY, SET
2	E-5878	1	HOUR METER	6	E-6207	2	FUSE, #ATC-30
3	E-5873	1	KEY SWITCH (INCLUDES #5)	7	E-6417	1	KAWASAKI HARNESS ADAPTER
4	E-6403	1	PTO SWITCH				

JACK ASSEMBLY 629-829A

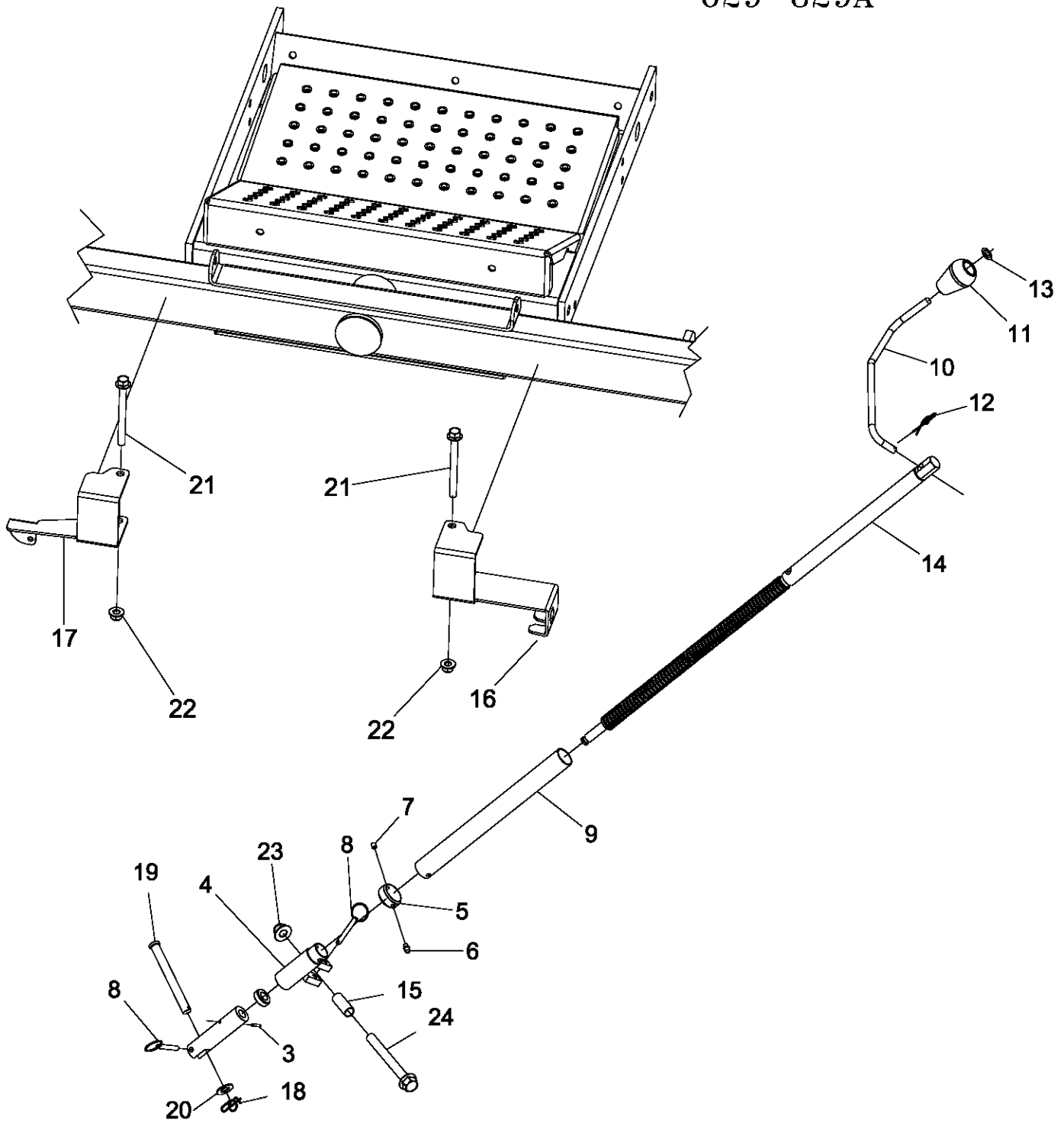

ITEM	PART #	QTY.	DESCRIPTION	ITEM	PART #	QTY.	DESCRIPTION
1	629-825P	1	LOWER JACK CONNECTOR	13	F-1913	1	PUSH RETAINER 3/8 INCH
2	D-3857	1	THRUST BEARING	14	629-836W	1	SHAFT, JACK DRIVE WELDMENT
3	F-1458	1	ROLL PIN, 1/8 X 3/4	15	629-826P	1	SPACER, JACK
4	629-822W	1	DECK FLIP COLLAR WELDMENT	16	629-827P	1	JACK MOUNT BRACKET, LH
5	629-817P	1	JACK TUBE LOCKING COLLAR	17	629-828P	1	JACK MOUNT BRACKET, RH
6	H-1056	1	1/4" Grease Fitting	18	H-2239	1	1/2" Rue Ring
7	F-1467	1	Setscrew, 1/4-20 X 5/16 Nyloc	19	H-2240	1	1/2" x 4-1/2" Clevis Pin
8	F-2183	2	1/4 x 1-1/2" QUICK PIN	20	F-1521	1	1/2" WASHER, CUSTOM
9	629-823P	1	TUBE, GREASE COVER	21	F-2142	2	FHCS, 3/8-16 x 4", YZ, GR5
10	629-216P	1	629-216P	22	F-2151	2	Nut, 3/8-16 Nyloc, Flanged
11	H-2343	1	KNOB	23	F-2152	1	Nut, 1/2-13 Nyloc, Flanged
12	F-1492	1	5/16-3/8 Rue Ring	24	F-2181	1	FHCS, 1/2-13 X 4.50, YZ, GR8

Repair Parts Manual

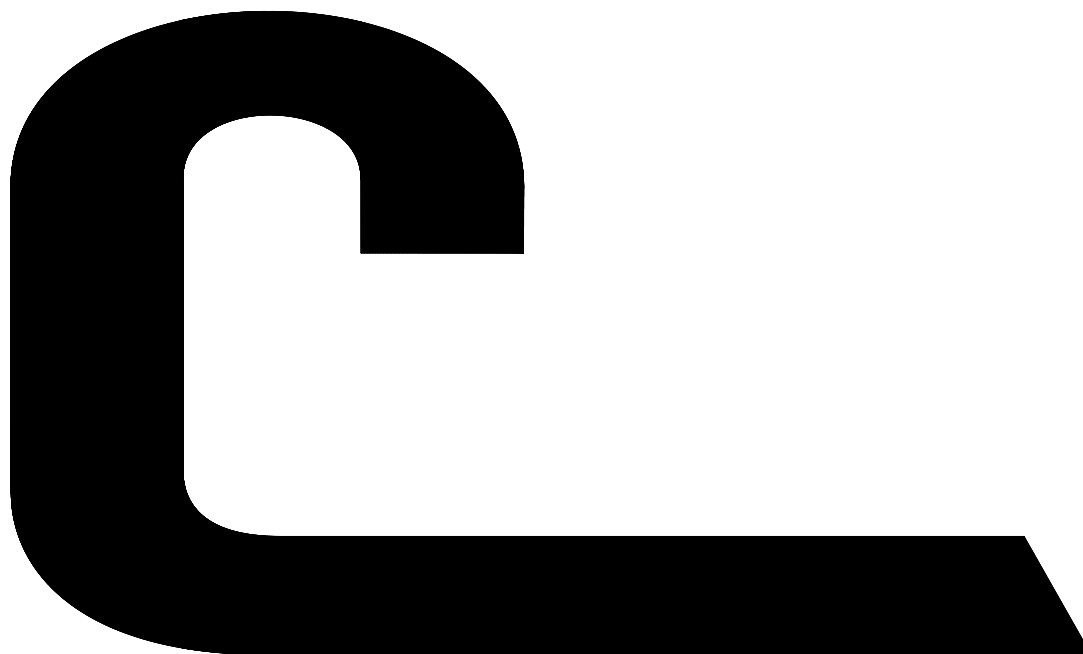

BOSS^{XL}

1510

Country Clipper Division
Shivvers Manufacturing Inc.
613 W. English St.
Corydon, IA 50060-0467
Ph. 641-872-2544
Fax. 641-872-1593