

Repair Parts Manual

C C O U N T R Y
CLIPPER®
Z E R O T U R N M O W E R

CHARGER™

1040

Congratulations for buying a **Country Clipper** product. Your **Country Clipper** Zero Turn Radius Riding Mower was designed and built to provide long and trouble free service. Keep in mind that it, like any other mechanical device, can be potentially dangerous if used improperly, and hazard control and accident prevention are dependent upon the awareness, concern, prudence, and proper training of personnel involved in the operation, transport, maintenance, and storage of the equipment. Study this manual and pay special attention to the important Safety Precautions on pages 3-5. Following these instructions will help you continue to enjoy the trouble-free performance expected of the **Country Clipper** product.

COUNTRY CLIPPER CHARGER

1040

ZERO TURN RADIUS MOWER

TABLE OF CONTENTS

SECTION 1 – MOWER DECKS AND RELATED PARTS

1. 52" DECK ASSEMBLY
2. 52" TRI-PORT DECK ASSEMBLY
3. 60" DECK ASSEMBLY
4. DECK SPINDLE ASSEMBLY
5. DOUBLE IDLER & RELATED PARTS - 52" DECK
6. DOUBLE IDLER & RELATED PARTS - 52" TRI-PORT DECK
7. DOUBLE IDLER & RELATED PARTS - 60" DECK
8. LIFT HANDLE ASSEMBLY & RELATED PARTS
9. LIFT ASSEMBLY & RELATED PARTS
10. TRANSMISSION IDLERS & RELATED PARTS

SECTION 2 – TRACTOR FRAME AND RELATED PARTS

11. CASTER WHEEL ASSEMBLY
12. FRAME SIDES & RELATED PARTS
13. FENDER ASSEMBLY
14. SEAT, FOOT DECK ASSEMBLY & RELATED PARTS
15. FRONT STEP ASSEMBLY
16. R.O.P.S. ASSEMBLY (ROLL OVER PROTECTION SYSTEM) & RELATED PARTS

SECTION 3 – TRACTOR DRIVE AND RELATED PARTS

17. FUEL TANK ASSEMBLY
18. JOYSTICK STEERING CONTROL & RELATED PARTS
19. JOYSTICK STEERING CONTROL & RELATED PARTS (CON'T)
20. JOYSTICK STEERING CONTROL & RELATED PARTS (CON'T)
21. TWIN STICK STEERING CONTROL & RELATED PART
22. PARKING BRAKE ASSEMBLY & RELATED PARTS
23. GEAR MOTOR WHEEL ASSEMBLY
24. MOTOR ASSEMBLY & RELATED PARTS FOR 25.5HP KAWASAKI
25. MOTOR ASSEMBLY & RELATED PARTS FOR 26HP EFI KOHLER
26. HIGH PRESSURE LINES & FITTINGS
27. OIL RETURN LINES & COOLER ASSEMBLY
28. E-6415 WIRE HARNESS ASSEMBLY & RELATED PARTS
29. E-6416 WIRE HARNESS ASSEMBLY & RELATED PARTS
30. E-6417 WIRE HARNESS ADAPTER & RELATED PARTS
31. E-6547 WIRE HARNESS ADAPTER & RELATED PARTS

52" HEAVY
DECK ASSEMBLY
{668V-002A}

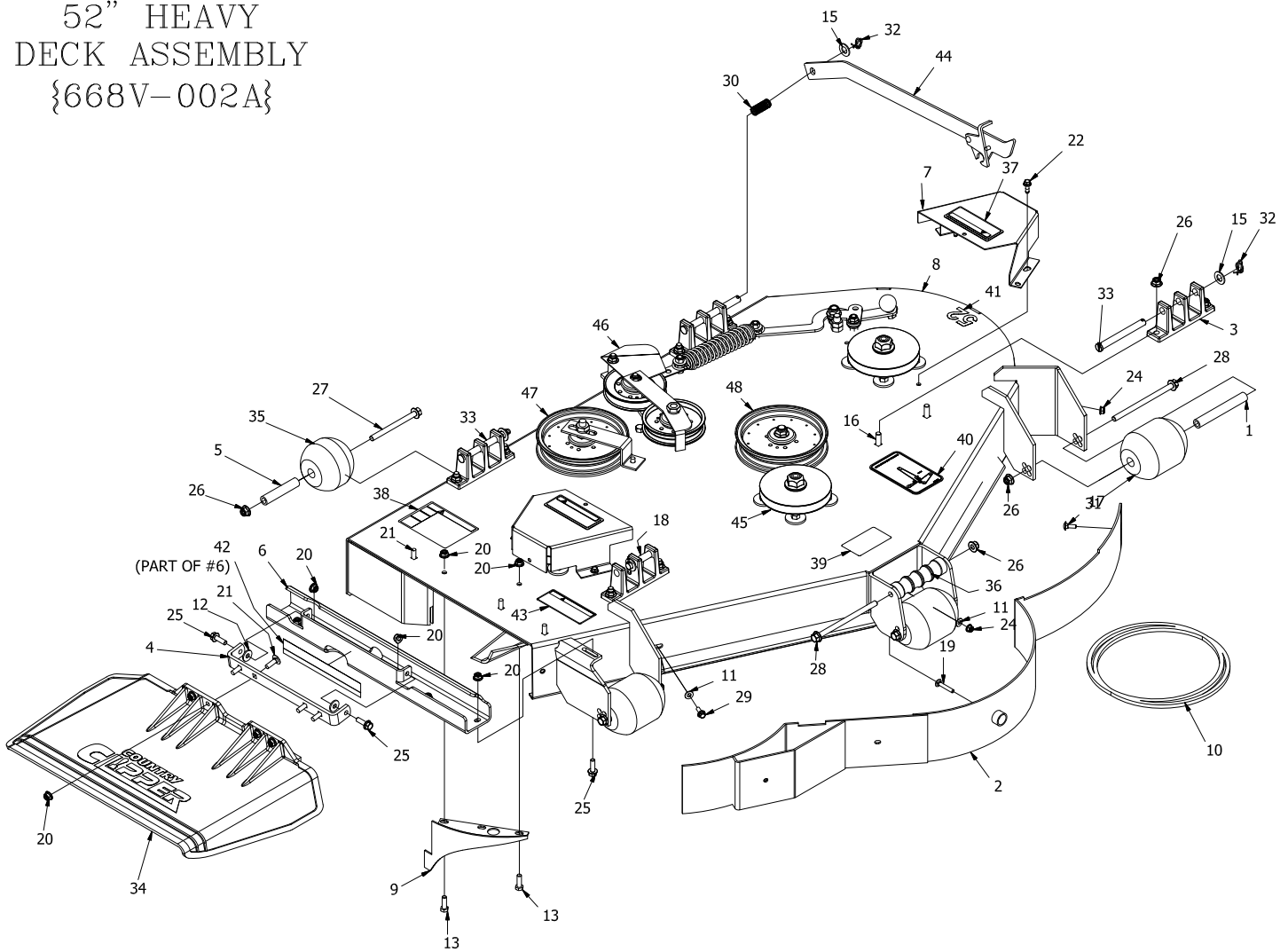

REF NO.	PART NO.	QTY.	DESCRIPTION	REF NO.	PART NO.	QTY.	DESCRIPTION
1	609-183P	3	BUSHING	26	F-2151	18	Nut, 3/8-16 Nyloc, Flanged
2	629-229W	1	DUST BAFFLE, 52"	27	F-2160	2	FHCS, 3/8-16 x 4 1/2", YZ, GR5
3	643-016W	4	Hanger Weldment	28	F-2161	4	FHCS, 3/8-16 x 6", YZ, GR5
4	643-110P	1	CHUTE HINGE	29	F-2162	1	FHCS, 1/4-20 x 3/4", GR5, YZ
5	643-126P	2	BUSHING	30	F-2575	1	SPRING, COMP .656 X .052 X 1.97
6	643-135A	1	OUTLET STIFFENER w/DECAL	31	H-1948	3	Roller, 3-3/4 DIA. x 4-13/16L
7	660-146A	2	PULLEY COVER w/DECALS	32	H-2239	4	1/2" Rue Ring
8	668-075A	1	52" HEAVY DECK w/DECALS	33	H-2240	2	1/2" x 4-1/2" Clevis Pin
9	686-006W	1	SPLITTER BAFFLE	34	H-2723	1	Chute, Discharge, Small
10	D-3872	1	BELT, B-184	--	643-111A	1	CHUTE ASSEMBLY
11	F-1009-01	2	1/4" Flat Washer	35	H-2772	2	Roller, 3-3/4 DIA. x 3 1/4"L
12	F-1009-02	2	5/16" Flat Washer	36	H-2787	1	GRIP, DECK HANDLE
13	F-1015-15	2	5/16-18 x 1" Capscrew	37	P-10935	2	Decal, WARNING
14	F-1394	3	3/8-16 x 1" Capscrew	38	P-10941	1	DECAL "DANGER ROTATING BLADES"
15	F-1521	8	1/2" WASHER, CUSTOM	39	P-11413	1	DECAL, HOIST POINT
16	F-1672	8	3/8-16 x 1-1/4" Carriage Bolt	40	P-11932	1	DECAL, JAZEE DECK BELT ROUTING
17	F-1823	1	Carriage Bolt, 1/4 X 3/4"	41	P-11951	1	DECAL, DECK SIZE, 52
18	F-1889	1	1/2 x 2-5/8" Clevis Pin	42	P-12496	1	DECAL, MISSING CHUTE
19	F-1935	1	CARRIAGE BOLT, 1/4 X 1-1/2"	43	P-12706	1	WARNING DECAL, DISCHARGE CHUTE
20	F-2063	13	Nut, 5/16-18 Nyloc, Flanged	44	625-114A	1	DECK PROP ASS'Y, EDGE XLT
21	F-2066	8	5/16-18 x 1" CARRIAGE BOLT,	45	-----	3	SPINDLE ASS'Y (SEE pg.4)
22	F-2119	4	FHCS, 1/4-20 x 0.75, YZ, LOCK PATCH, GR5	46	-----	1	DOUBLE IDLER ASS'Y (SEE pg.5)
23	F-2124	1	FHCS, 3/8-16 x 0.75, YZ, GR5	47	-----	1	REAR IDLER ASS'Y (SEE pg.5)
24	F-2132	2	NUT, 1/4-20 NYLOC, FLANGED	48	-----	1	FRONT IDLER ASS'Y (SEE pg.5)
25	F-2148	3	FHCS, 5/16-18 x 1.00, YZ, GR5				

52" TRI-PORT
DECK ASSEMBLY
{686K-002A}

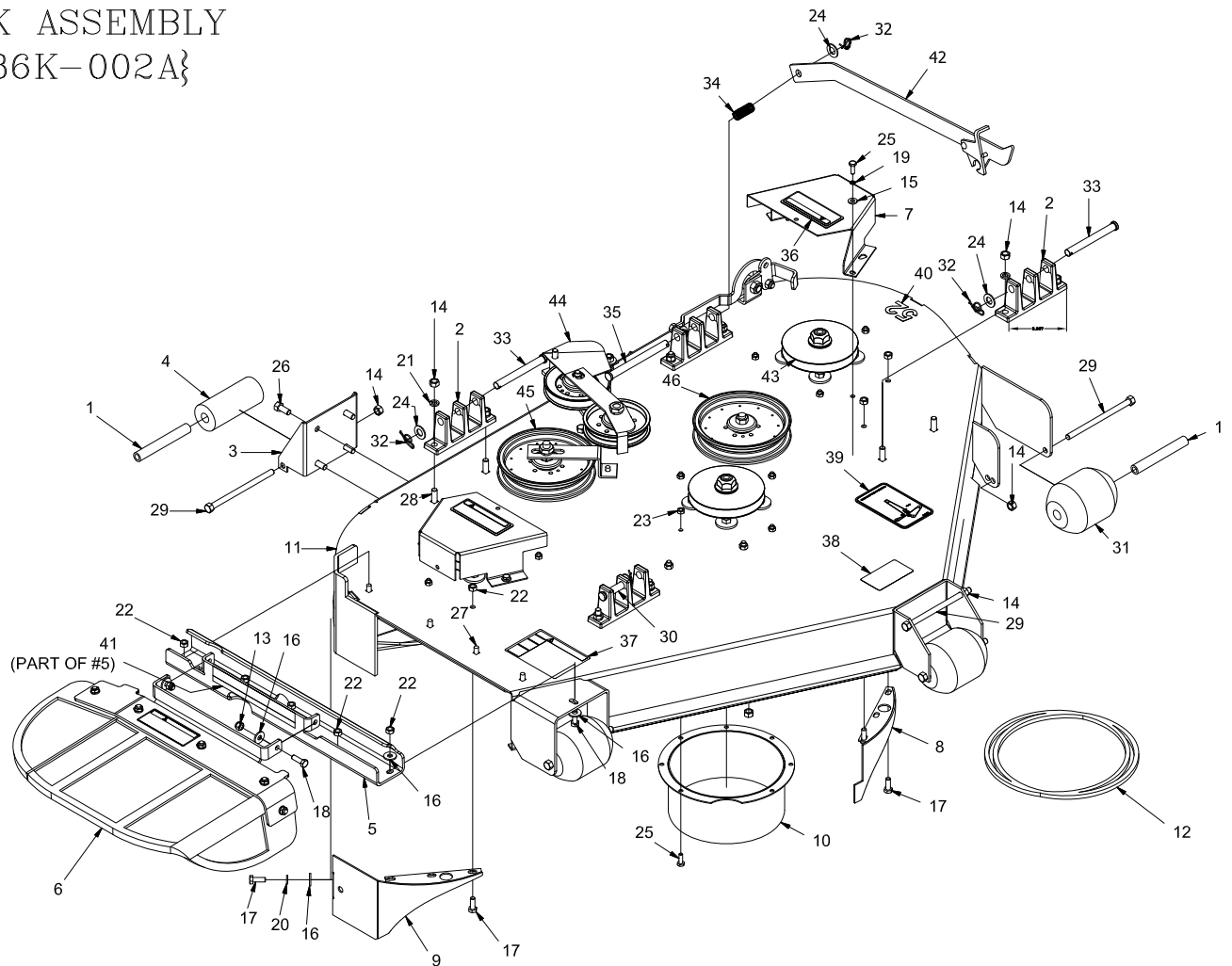

REF NO.	PART NO.	QTY.	DESCRIPTION	REF NO.	PART NO.	QTY.	DESCRIPTION
1	609-183P	5	BUSHING	24	F-1521	6	1/2" WASHER, CUSTOM
2	643-016W	4	Hanger Weldment	25	F-1538	14	1/4-20 x 3/4" Capscrew
3	659-139P	2	SCALPER BRACKET	26	F-1558	8	3/8-16 x 7/8" Capscrew
4	660-076P	2	ROLLER, 2"	27	F-1671	5	5/16-18 x 3/4" CARRIAGE BOLT
5	643-135A	1	OUTLET STIFFENER w/DECAL	28	F-1672	8	3/8-16 x 1-1/4" Carraige Bolt
6	660-122A	1	RUBBER CHUTE ASS'Y, SM.	29	F-1741	6	3/8-16 x 6" Capscrew
7	660-146A	2	PULLEY COVER w/DECALS	30	F-1889	1	1/2 x 2-5/8" Clevis Pin
8	686-006W	2	SPLITTER BAFFLE	31	H-1948	3	Roller, 3-3/4 DIA. x 4-13/16L
9	686-018W	1	BAFFLE, DISCHARGE WLDT	32	H-2239	4	1/2" Rue Ring
10	686-059W	3	8" TUBE WLDT.	33	H-2240	2	1/2" x 4-1/2" Clevis Pin
11	686-100A	1	52" TRIPORT DECK w/DECALS	34	H-2575	1	SPRING, COMP .656 X .052 X 1.97
12	D-3872	1	BELT, B-184	35	H-2718	1	1/2" x 5-1/2" Clevis Pin
13	F-1005-02	2	5/16-18 Nyloc Nut	36	P-10935	2	Decal, WARNING
14	F-1005-03	33	3/8-16 Stover Nut	37	P-10941	1	DECAL "DANGER ROTATING BLADES"
15	F-1009-01	4	1/4" Flat Washer	38	P-11413	1	DECAL, HOIST POINT
16	F-1009-02	6	5/16" Flat Washer	39	P-11932	1	DECAL, JAZEE DECK BELT ROUTING
17	F-1015-14	6	5/16-18 x 7/8" Capscrew	40	P-11951	1	DECAL, DECK SIZE, 52
18	F-1015-15	3	5/16-18 x 1" Capscrew	41	P-12496	1	DECAL, MISSING CHUTE
19	F-1019-01	4	1/4" LockWasher	42	625-114A	1	DECK PROP ASS'Y, EDGE XLT
20	F-1019-02	1	5/16" LockWasher	43	-----	3	SPINDLE ASS'Y (SEE pg.4)
21	F-1019-03	20	3/8" LOCKWASHER	44	-----	1	DOUBLE IDLER ASS'Y (SEE pg.6)
22	F-1125	12	5/16-18 Stover Nut	45	-----	1	REAR IDLER ASS'Y (SEE pg.6)
23	F-1158	10	1/4-20 Stover Nut	46	-----	1	FRONT IDLER ASS'Y (SEE pg.6)

60" HEAVY
DECK ASSEMBLY
{668U-002A}

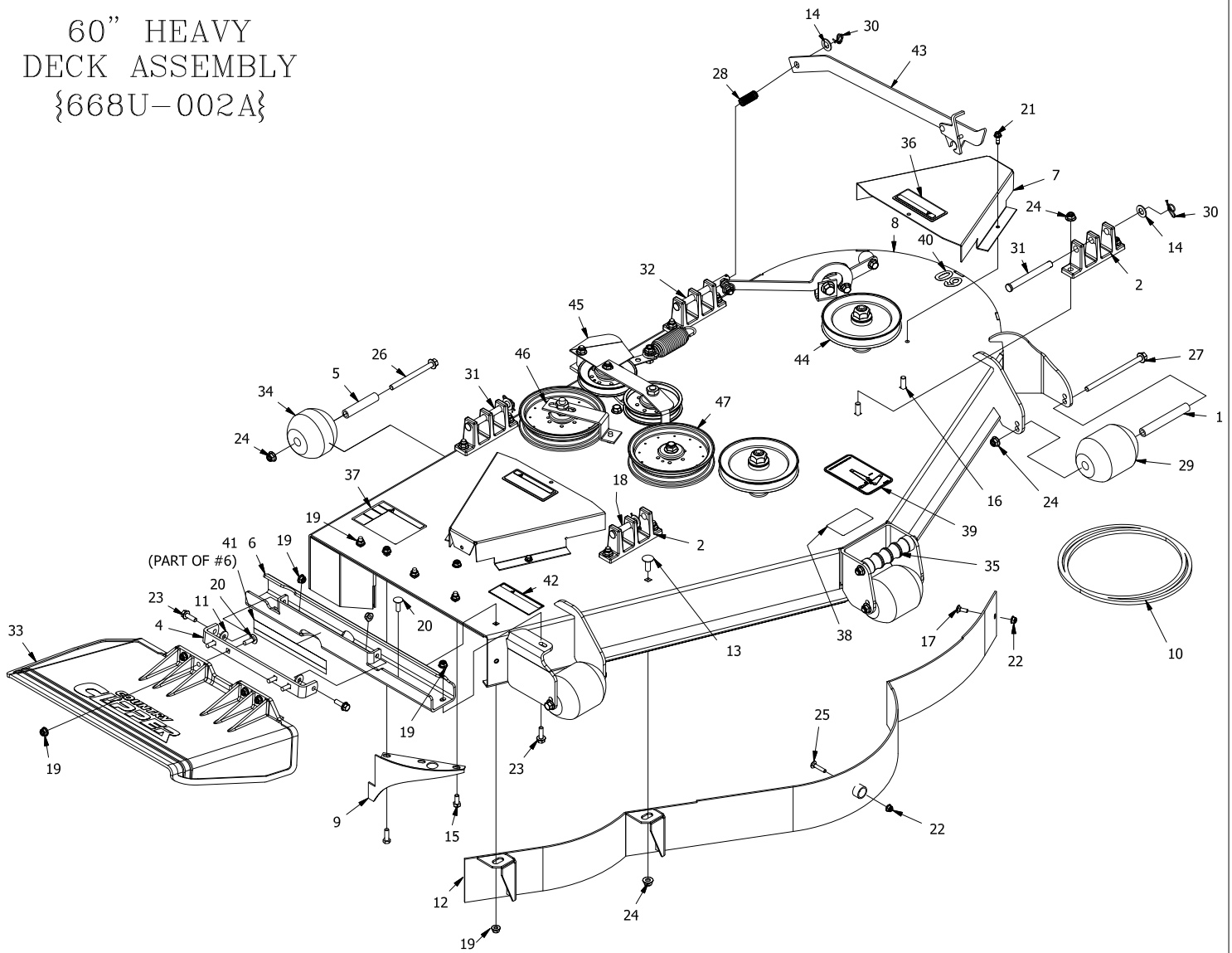

REF NO.	PART NO.	QTY.	DESCRIPTION	REF NO.	PART NO.	QTY.	DESCRIPTION
1	609-183P	3	BUSHING	25	F-2157	1	CARRIAGE BOLT, 1/4 X 1-1/4"
2	643-016W	4	Hanger Weldment	26	F-2160	2	FHCS, 3/8-16 x 4 1/2", YZ, GR5
3	643-104W	1	60" DUST BAFFLE WELDMENT	27	F-2161	4	FHCS, 3/8-16 x 6", YZ, GR5
4	643-110P	1	CHUTE HINGE	28	F-2575	1	SPRING, COMP .656 X .052 X 1.97
5	643-126P	2	BUSHING	29	H-1948	3	Roller, 3-3/4 DIA. x 4-13/16L
6	643-135A	1	OUTLET STIFFENER w/DECAL	30	H-2239	4	1/2" Rue Ring
7	668-061A	2	PULLEY COVER w/DECALS	31	H-2240	2	1/2" x 4-1/2" Clevis Pin
8	668-076A	1	60" DECK WLD w/DECALS	32	H-2718	1	1/2" x 5-1/2" Clevis Pin
9	686-006W	1	SPLITTER BAFFLE	33	H-2723	1	Chute, Discharge, Small
10	D-3872	1	BELT, B-184	--	643-111A	1	CHUTE ASSEMBLY
11	F-1009-02	2	5/16" Flat Washer	34	H-2772	2	Roller, 3-3/4 DIA. x 3 1/4"L
12	F-1015-15	1	5/16-18 x 1" Capscrew	35	H-2787	1	GRIP, DECK HANDLE
13	F-1274	1	3/8-16 X 1" CARRIAGE BOLT	36	P-10935	2	Decal, WARNING
14	F-1521	6	1/2" WASHER, CUSTOM	37	P-10941	1	DECAL "DANGER ROTATING BLADES"
15	F-1546	1	5/16-18 x 3/4" Capscrew	38	P-11413	1	DECAL, HOIST POINT
16	F-1672	8	3/8-16 x 1-1/4" Carriage Bolt	39	P-11932	1	DECAL, JAZEE DECK BELT ROUTING
17	F-1823	1	Carriage Bolt, 1/4 X 3/4"	40	P-11952	1	DECAL, DECK SIZE, 60
18	F-1889	1	1/2 x 2-5/8" Clevis Pin	41	P-12496	1	DECAL, MISSING CHUTE
19	F-2063	14	Nut, 5/16-18 Nyloc, Flanged	42	P-12706	1	WARNING DECAL, DISCHARGE CHUTE
20	F-2066	9	5/16-18 x 1" CARRIAGE BOLT,	43	625-114A	1	DECK PROP ASS'Y, EDGE XLT
21	F-2119	4	FHCS, 1/4-20 x 0.75, YZ, LOCK PATCH, GR5	44	-----	3	SPINDLE ASS'Y (SEE pg.4)
22	F-2132	2	NUT, 1/4-20 NYLOC, FLANGED	45	-----	1	DOUBLE IDLER ASS'Y (SEE pg.7)
23	F-2148	3	FHCS, 5/16-18 x 1.00, YZ, GR5	46	-----	1	REAR IDLER ASS'Y (SEE pg.7)
24	F-2151	24	Nut, 3/8-16 Nyloc, Flanged	47	-----	1	FRONT IDLER ASS'Y (SEE pg.7)

TORQUE TO 140 ft-lb

DECK SPINDLE ASSEMBLY 629FN-001A

PULLEY NOT INCLUDED *2
IN ASSEMBLY

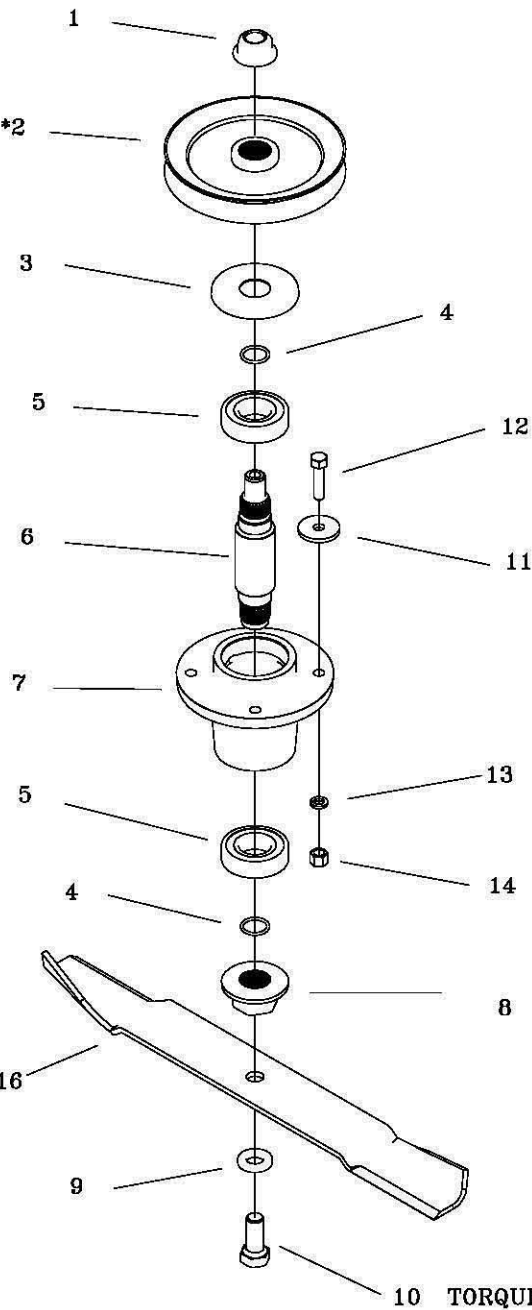

BLADE NOT INCLUDED *16
IN ASSEMBLY

15 (APPLY THIN LAYER OF CHEVRON RYKOTAC GREASE TO THE TOP SURFACES OF THE BEARING AND HOUSING PRIOR TO INSTALLING ITEM #3 (BEARING CAP).

NEW MOWERS ARE SHIPPED WITH 3 to 4 oz OF CHEVRON SRI NLGI 2 GREASE INSIDE EACH SPINDLE HOUSING.

10 TORQUE TO 100 ft-lb

REF NO.	PART NO.	QTY.	DESCRIPTION	REF NO.	PART NO.	QTY.	DESCRIPTION
1	F-2078	1	3/4-6 TOP LOCK NUT	12	F-1572	4	3/8-24 X 1.5 CAP SCREW
2	668-050P	*	52" DECK CENTER PULLEY	13	F-1019-03	4	3/8 LOCK WASHER
*	668-042P	*	60" DECK CENTER PULLEY	14	F-1573	4	3/8-24 LOCK NUT
3	609-292P	1	CAP, BEARING	15	H-2707	1	GREASE PACKET
4	H-2639	2	O'RING, RUBBER	16	H-2884	-	FUSION, HIGH LIFT 18 3/8" CUT 52"
5	D-3867	2	BEARING, #6206	-	H-2886	-	FUSION, HIGH LIFT, 21" CUT 60"
6	609-289P	1	SHAFT, SPINDLE	OPTIONAL BLADES			
7	609-285P	1	HOUSING, SPINDLE				
8	609-288P	1	BLADE DRIVER	-	H-2660	-	BLADE, LOW LIFT, 18 3/8" CUT, 52"
9	660-099P	1	BLADE WASHER	-	H-2661	-	BLADE, LOW LIFT, 21" CUT, 60"
10	F-2073	1	5/8-11 X 1.5 HHCS GR. 8	-	H-2666	-	BLADE, GATOR, 18 3/8" CUT 52"
11	609-034P	4	SPINDLE SPACER, WASHER	-	H-2667	-	BLADE, GATOR, 21" CUT 60"

DOUBLE IDLER DRIVE BELT IDLER & RELATED PARTS 52" DECK

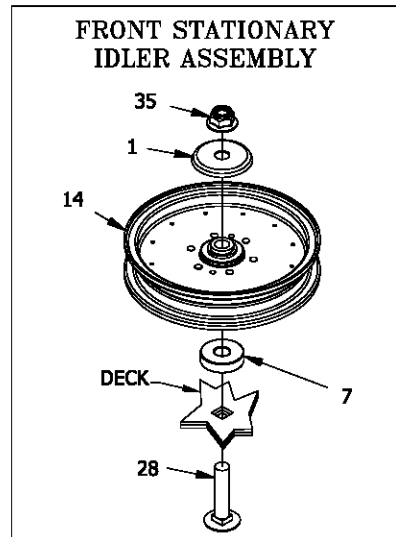
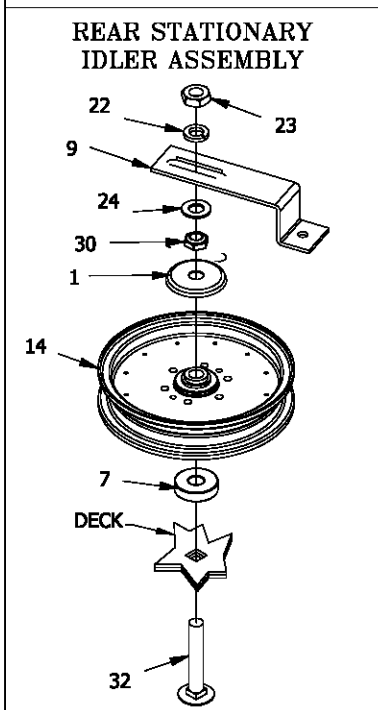
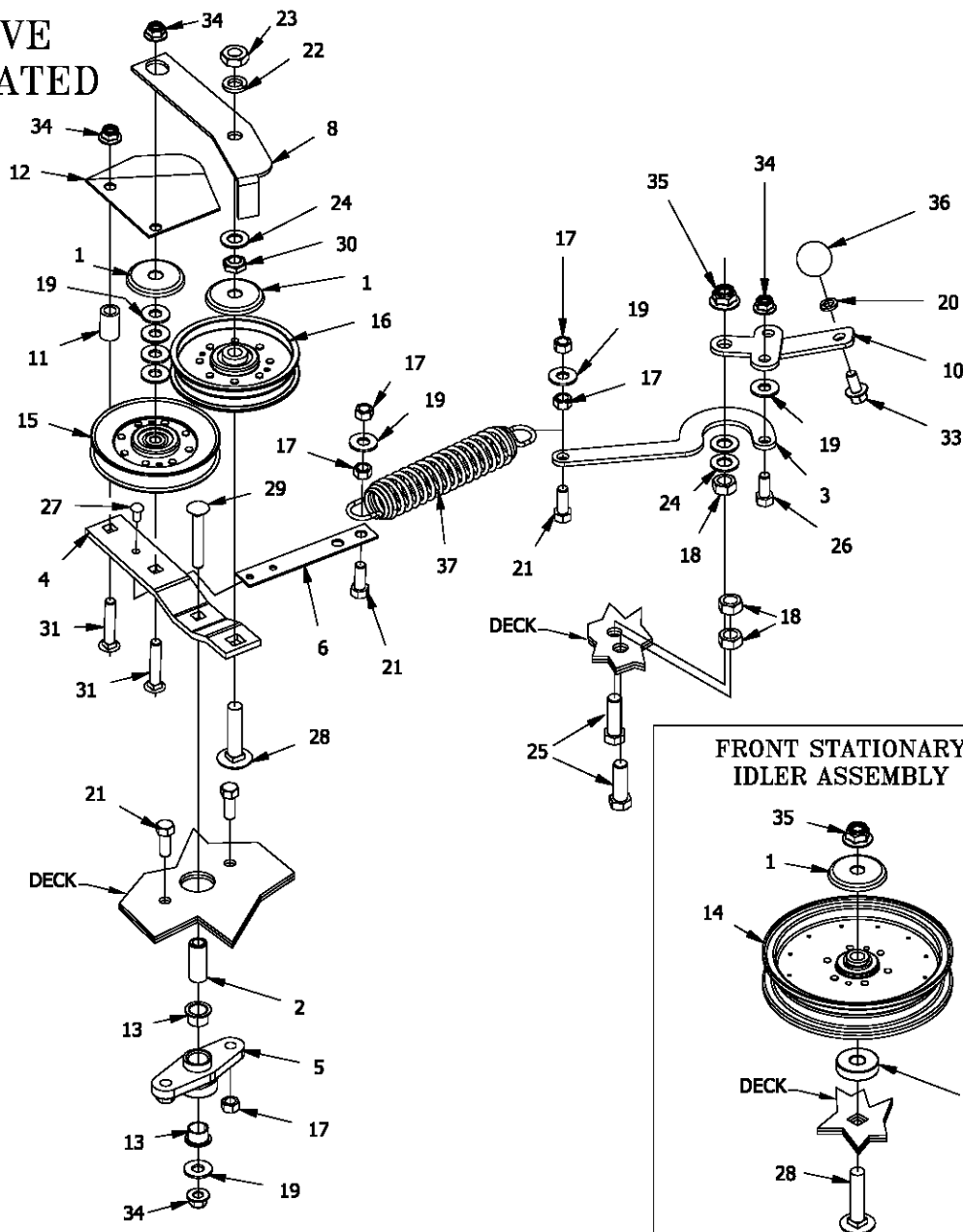

REF NO.	PART NO.	QTY.	DESCRIPTION	REF NO.	PART NO.	QTY.	DESCRIPTION
1	620-201P	4	WASHER, BEARING CAP	20	F-1019-03	13	3/8" LOCKWASHER
2	659-085P	1	Mounting Pin	21	F-1394	4	3/8-16 x 1" Capscrew
3	660-031P	1	Belt Tightner Arm	22	F-1464	2	1/2" LOCKWASHER
4	660-036P	1	Idler Arm	23	F-1489	2	1/2-13 Hex Jam Nut
5	660-039P	1	Double Idler Mount	24	F-1521	8	1/2" WASHER, CUSTOM
6	660-081P	1	EXTENSION FOR SPRING	25	F-1526	2	1/2-13 x1-1/2" Capscrew
7	660-082P	2	SPACER	26	F-1558	1	3/8-16 x 7/8" Capscrew
8	660-107P	1	BELT KEEPER	27	F-1733	1	1/4" x 1/2" DRIVE SCREW
9	660-114P	1	BELT KEEPER, SINGLE END	28	F-1822	2	1/2-13 X 2-1/4" CARRIAGE BOLT
10	660-184P	1	HANDLE, BELT TENSIONER	29	F-1865	1	3/8-16 x 2-1/2" Carraige Bolt
11	668-021P	1	SPACER, BELT GUARD	30	F-1966	2	1/2-13 THIN NYLOC NUT
12	668-029P	1	BELT GUARD	31	F-1976	2	3/8-16 x 2" Carraige Bolt
13	D-3730	2	Flanged Bushing 5/8" Bore	32	F-2047	1	1/2-13 X 3" CARRIAGE BOLT
14	D-3903	2	PULLEY, FLAT IDLER, 6" (NTN)	33	F-2124	1	FHCS, 3/8-16 x 0.75, YZ, GR5
15	D-3923	1	PULLEY, V-IDLER, 4.59 OD, AB, NTN	34	F-2151	18	Nut, 3/8-16 Nyloc, Flanged
16	D-3924	1	PULLEY, FLAT IDLER, NTN, DBL INSERT	35	F-2152	2	Nut, 1/2-13 Nyloc, Flanged
17	F-1005-03	6	3/8-16 Stover Nut	36	H-2405	1	BALL, 1-1/4"
18	F-1005-05	3	1/2-13 Stover Nut	37	H-2619	1	SPRING, 5 X 1-1/2, TAPERED ENDS
19	F-1009-03	8	3/8" Flat Washer				

DOUBLE IDLER DRIVE BELT IDLER & RELATED PARTS 52" TRI-PORT DECK

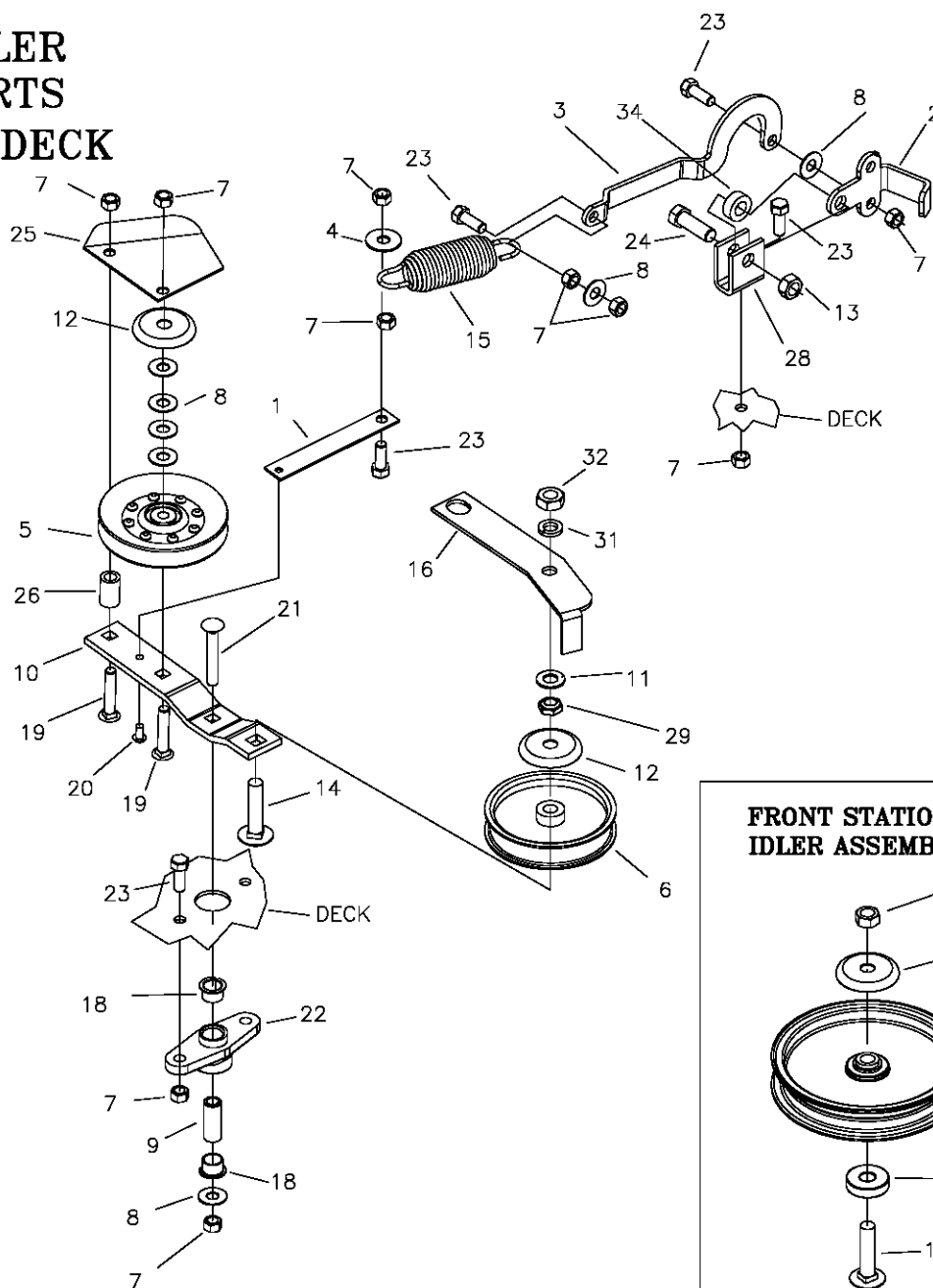

RIGHT REAR STATIONARY IDLER ASSEMBLY

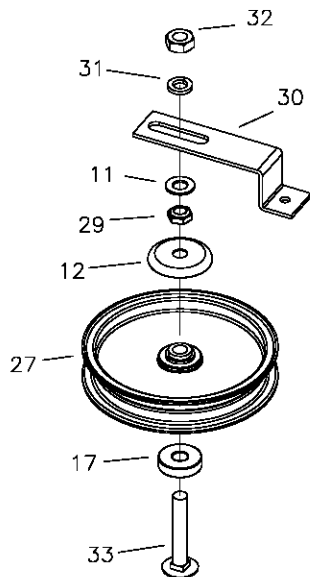

FRONT STATIONARY IDLER ASSEMBLY

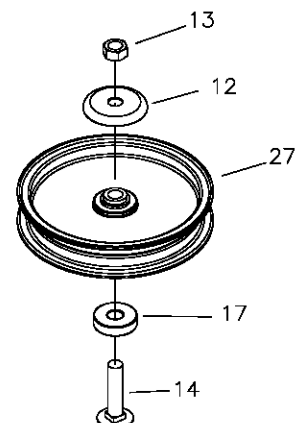

REF NO.	PART NO.	QTY.	DESCRIPTION	REF NO.	PART NO.	QTY.	DESCRIPTION
1	660-035P	1	EXTENSION FOR SPRING	22	660-039P	1	MOUNT, DOUBLE IDLER
2	686-101P	1	HANDLE, BELT TIGHTENER	23	F-1394	6	3/8-16 X 1" GR. 5
3	686-081P	1	BELT TENSIONER	24	F-1526	1	1/2-13 X 1-1/2" GR. 5
4	F-2083	1	WASHER, 3/8 FENDER	25	668-029P	1	BELT GUARD
5	D-3923	1	"V" IDLER PULLEY	26	668-021P	1	SPACER, BELT GUARD
6	D-3924	1	IDLER PULLEY	27	D-3903	2	6" IDLER PULLEY
7	F-1005-03	10	3/8 LOCK NUT	28	661-015P	1	SHACKLE
8	F-1009-03	7	3/8 FLAT WASHER	29	F-1966	4	1/2" THIN NYLOC NUT
9	659-085P	1	MOUNTING PIN	30	660-114P	1	BELT KEEPER, SINGLE END
10	660-036P	1	IDLER ARM	31	F-1464	2	1/2" LOCK WASHER
11	F-1521	4	1/2" FLAT WASHER	32	F-1489	2	1/2" THIN NUT
12	620-201P	4	BEARING CAP	33	F-2047	1	1/2"-13 X 3" CARRIAGE BOLT
13	F-1005-05	2	1/2" LOCK NUT	34	660-038P	1	3/8" SPACER
14	F-1822	2	1/2-13 X 2-1/4" GR. 5				
15	H-2619	1	SPRING, 5x1-1/2, TAPERED ENDS				
16	660-107P	1	BELT KEEPER				
17	660-082P	2	SPACER				
18	D-3730	2	BUSHING, TEFLON COATED				
19	F-1976	2	3/8-16 X 1-3/4" CARRIAGE BOLT				
20	F-1733	1	1/4" DRIVE STUD				
21	F-1865	1	3/8-16 X 2-1/2" CARRIAGE BOLT				

DOUBLE IDLER DRIVE BELT IDLER & RELATED PARTS 60" DECK

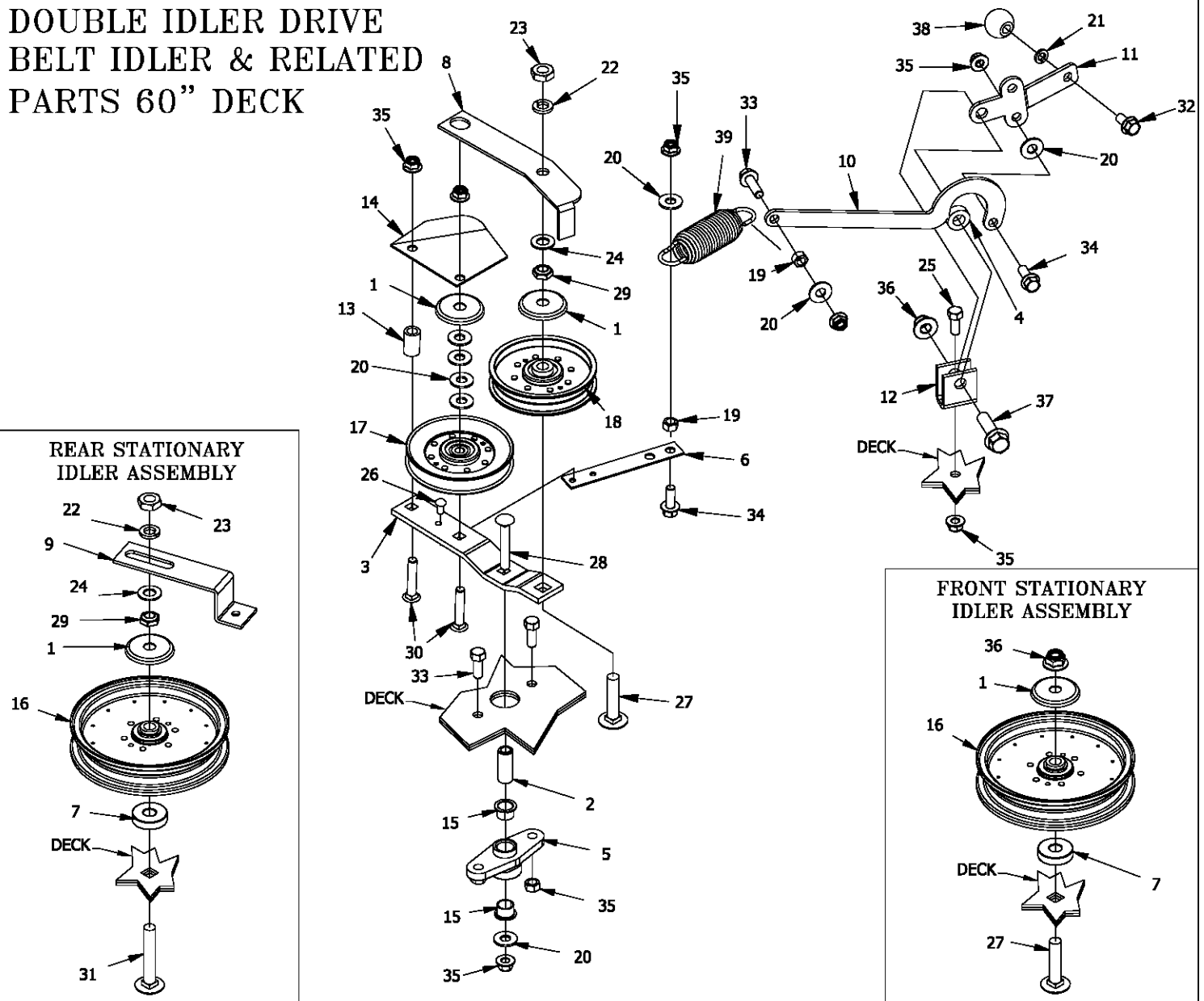

REF NO.	PART NO.	QTY.	DESCRIPTION	REF NO.	PART NO.	QTY.	DESCRIPTION
1	620-201P	4	WASHER, BEARING CAP	21	F-1019-03	13	3/8" LOCKWASHER
2	659-085P	1	Mounting Pin	22	F-1464	2	1/2" LOCKWASHER
3	660-036P	1	Idler Arm	23	F-1489	2	1/2-13 Hex Jam Nut
4	660-038P	1	3/8" Spacer	24	F-1521	6	1/2" WASHER, CUSTOM
5	660-039P	1	Double Idler Mount	25	F-1558	1	3/8-16 x 7/8" Capscrew
6	660-081P	1	EXTENSION FOR SPRING	26	F-1733	1	1/4" x 1/2" DRIVE SCREW
7	660-082P	2	SPACER	27	F-1822	2	1/2-13 X 2-1/4" CARRIAGE BOLT
8	660-107P	1	BELT KEEPER	28	F-1865	1	3/8-16 x 2-1/2" Carraige Bolt
9	660-114P	1	BELT KEEPER, SINGLE END	29	F-1966	2	1/2-13 THIN NYLOC NUT
10	660-182P	1	BELT TIGHTENER ARM	30	F-1976	2	3/8-16 x 2" Carraige Bolt
11	660-184P	1	HANDLE, BELT TENSIONER	31	F-2047	1	1/2-13 X 3" CARRIAGE BOLT
12	661-015P	1	SHACKLE	32	F-2124	1	FHCS, 3/8-16 x 0.75, YZ, GR5
13	668-021P	1	SPACER, BELT GUARD	33	F-2125	3	FHCS, 3/8-16 x 1.25, YZ, GR5
14	668-029P	1	BELT GUARD	34	F-2141	2	FHCS, 3/8-16 x 1", YZ, GR5
15	D-3730	2	Flanged Bushing 5/8" Bore	35	F-2151	24	Nut, 3/8-16 Nyloc, Flanged
16	D-3903	2	PULLEY, FLAT IDLER, 6" (NTN)	36	F-2152	2	Nut, 1/2-13 Nyloc, Flanged
17	D-3923	1	PULLEY, V-IDLER, 4.59 OD, AB, NTN	37	F-2154	1	FHCS, 1/2-13 x1-3/4", YZ, GR5
18	D-3924	1	PULLEY, FLAT IDLER, NTN, DBL INSERT	38	H-2405	1	BALL, 1-1/4"
19	F-1005-03	2	3/8-16 Stover Nut	39	H-2619	1	SPRING, 5 X 1-1/2, TAPERED ENDS
20	F-1009-03	8	3/8" Flat Washer				

LIFT HANDLE ASSEMBLY & RELATED PARTS

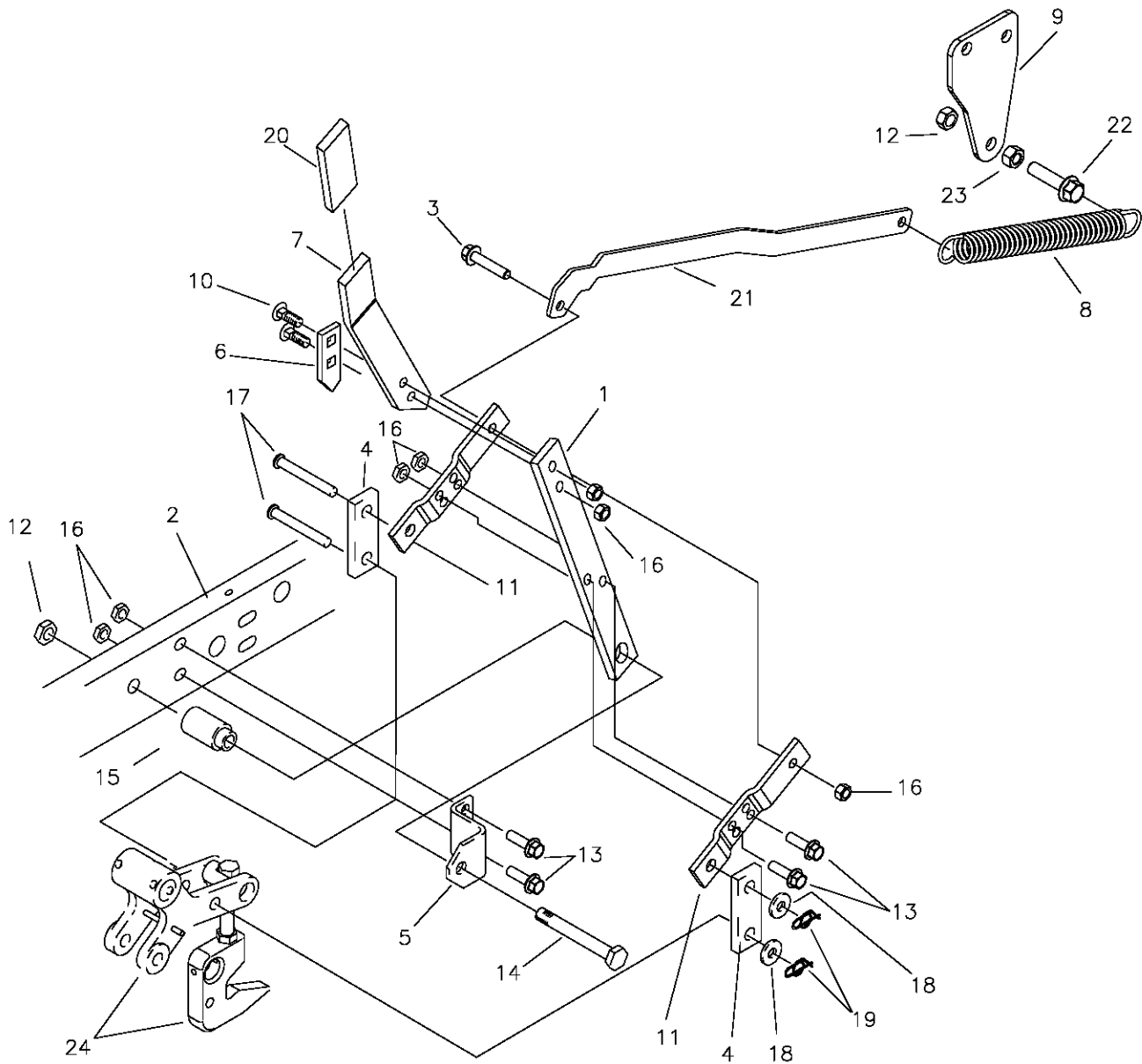

REF NO.	PART NO.	QTY.	DESCRIPTION	REF NO.	PART NO.	QTY.	DESCRIPTION
1	709-102P	1	LIFT HANDLE, LOWER	15	642-095P	1	HANDLE PIVOT PIN
2	659-022W	1	FRAME WELDMENT, LH.	16	F-2151	7	NUT, 3/8-16, NYLOC FLANGED
3	F-2126	1	3/8-16 X 2" CAPSCREW	17	F-1889	2	CLEVIS PIN, 1/2 X 2 5/8"
4	642-061P	2	HANDLE LINK	18	F-1521	2	1/2" FLAT WASHER
5	642-041P	1	HANDLE PIVOT BRACKET	19	H-2239	2	RUE RING, 1/2"
6	642-127P	1	TOP PEG LATCH PLATE	20	H-2324	1	VINYL GRIP, 3/8 X 1 1/2"
7	659-355P	1	LIFY HANDLE, UPPER	21	663-080P	1	BAR, SPRING EXT.
8	H-1610	1	SPRING, 1 1/2" OD. X 8"	22	F-2128	1	FHCS, 1/2-13 X 2", YZ GR5
9	663-120P	1	PLT, SPRING MOUNT	23	F-1011-05	7	HEX NUT, 1/2-13
10	F-1672	2	CARRIAGE BOLT, 3/8-16 X 1 1/4"	23	-----	-	SEE PAGE 9
11	642-060P	2	SPRING ANCHOR PLATE				
12	F-2152	2	NUT, 1/2-13, NYLOC FLANGED				
13	F-2125	4	FHCS, 1/2-13 X 1 1/4", YZ GR5				
14	F-1439	1	1/2-13 X 3" GR. 5				

LIFT ASSEMBLY & RELATED PARTS

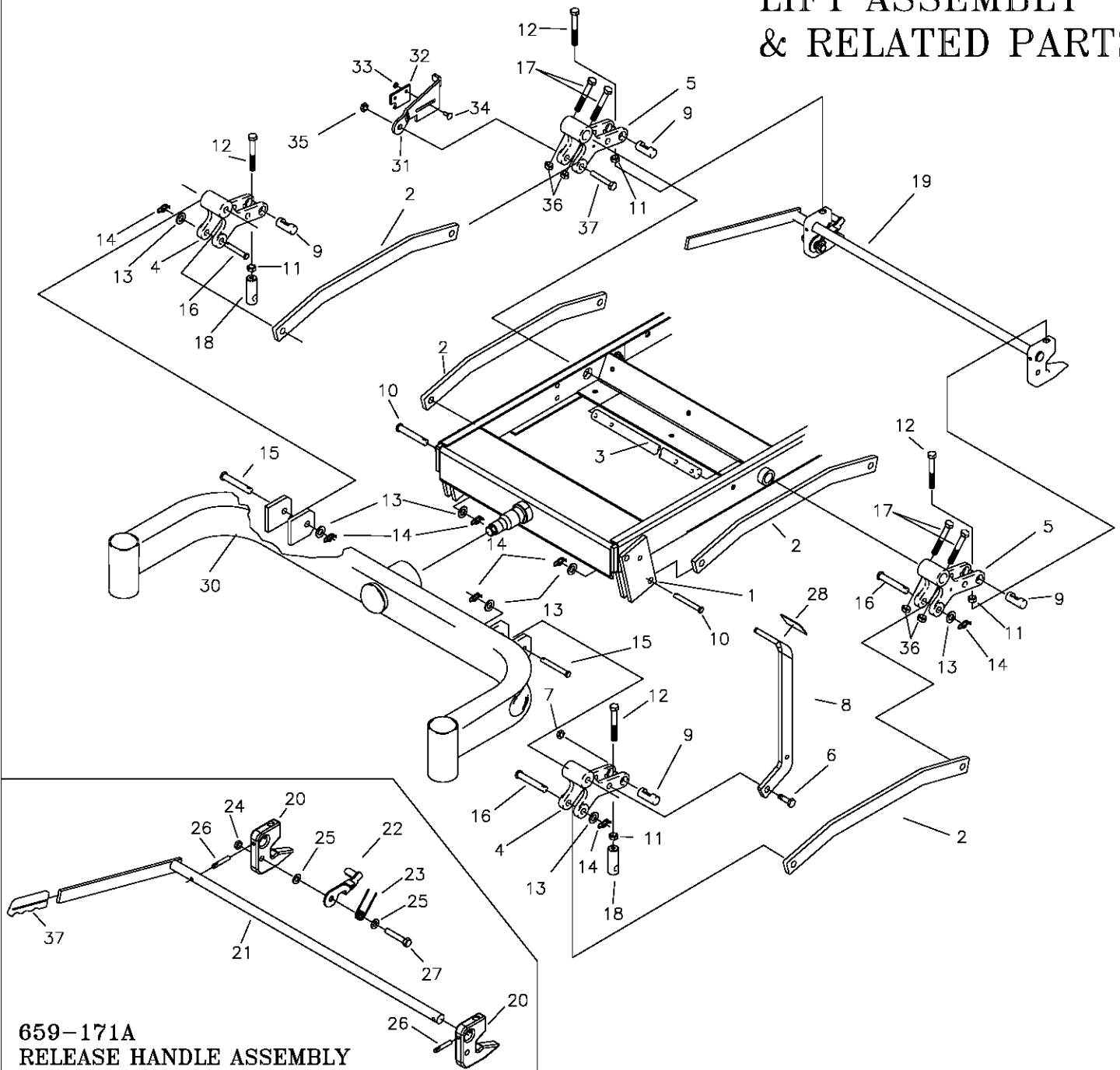

**659-171A
RELEASE HANDLE ASSEMBLY**

REF NO.	PART NO.	QTY.	DESCRIPTION	REF NO.	PART NO.	QTY.	DESCRIPTION
1	642-063P	2	DRAG BAR TAB	20	659-140P	2	DECK HOOK
2	659-299P	4	DRAG LINK BAR	21	659-148W	1	RELEASE HANDLE WELDMENT
3	620-051P	1	LIFT BAR	22	659-145P	1	HOOK KEEPER
4	642-081P	2	LIFT SLEEVE, FRONT	23	H-2547	1	SPRING, TORSION
5	642-193P	2	LIFT SLEEVE, REAR	24	F-2151	1	NUT, 3/8-16, NYLOC FLANGED
6	F-1879	1	5/16-18 X 1 1/4" GR.5	25	F-1009-03	2	WASHER, FLAT, 3/8"
7	F-1125	1	5/16-18 STOVER NUT	26	F-2187	2	PIN, GROOVED, "C", 1/4 X 1.50"
8	659-056P	1	DECK LIFT PEDAL	27	F-2126	1	FHCS, 3/8-16 X 2, YZ, GR5
9	642-177P	4	HANGER PIN	28	H-2401	1	TREAD PAD
10	F-1815	2	CLEVIS PIN, 1/2 X 1 1/2"	29	H-1926	1	1/4"x1" HANDLE GRIP
11	F-1489	4	NUT, 1/2" JAM	30	642-189W	1	FRONT AXLE WELDMENT
12	F-1936	4	1/2-13 X 3 1/2, 2" THREAD	31	663-089P	1	LATCH PLATE
13	F-1521	7	WASHER, 1/2 NARROW	32	659-170P	1	PLATE, CATCH
14	H-2239	7	RUE RING, 1/2"	33	F-2132	2	NUT, 1/4-20, NYLOC FLANGED
15	F-1890	2	CLEVIS PIN, 1/2 X 3 1/2"	34	F-1823	2	CARRIAGE BOLT, 1/4-20 X 3/4"
16	F-1898	3	CLEVIS PIN, 1/2 X 2 3/4"	35	F-2152	1	NUT, 1/2-13, NYLOC FLANGED
17	F-2039	4	5/16-24 x 2" HHCS	36	F-2041	4	5/16-24 JAM NUT
18	642-175P	2	ADJUSTABLE HANGER END	37	F-1828	1	1/2-13 x 3-1/2" CAPSCREW
19	659-171A	1	RELEASE HANDLE ASSEMBLY				

TRANSMISSION IDLERS & RELATED PARTS

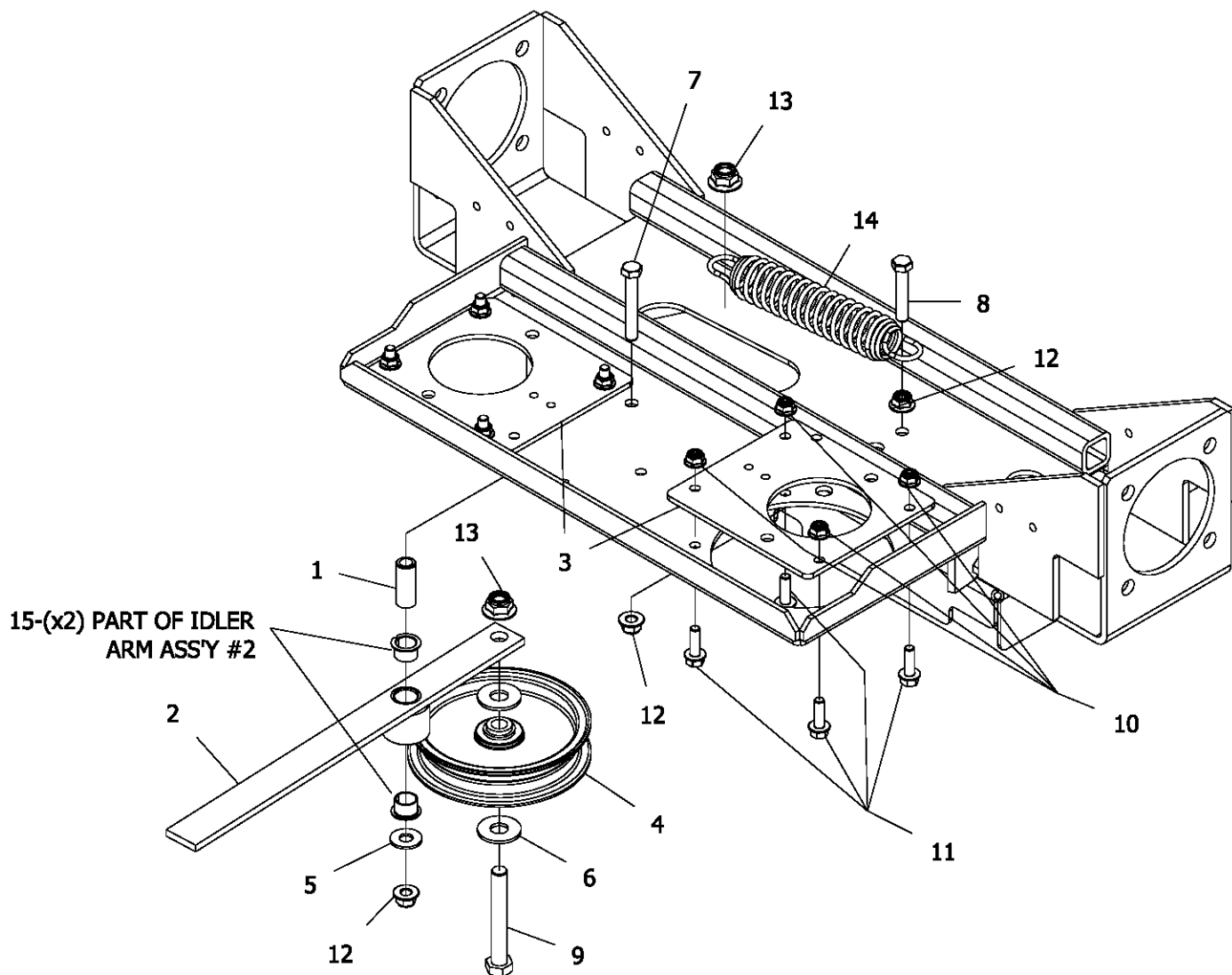

REF NO.	PART NO.	QTY.	DESCRIPTION	REF NO.	PART NO.	QTY.	DESCRIPTION
1	659-085P	1	Mounting Pin	9	F-1936	5	1/2-13 x 3-1/2" Capscrew
2	663-057A	1	Hydro Idler Arm Assembly	10	F-2063	66	Nut, 5/16-18 Nyloc, Flanged
3	663-146P	2	PLATE, PUMP ADAPTER	11	F-2148	10	FHCS, 5/16-18 x 1.00, YZ, GR5
4	D-3904	1	PULLEY, FLAT IDLER, 5"	12	F-2151	25	Nut, 3/8-16 Nyloc, Flanged
5	F-1009-03	2	3/8" Flat Washer	13	F-2152	31	Nut, 1/2-13 Nyloc, Flanged
6	F-1009-05	2	1/2" FLAT WASHER	14	H-2619	1	SPRING, 5 X 1-1/2, TAPERED ENDS
7	F-1015-30	1	3/8-16 x 2-1/2" Capscrew	15	D-3730	2	FLANGED BUSHING
8	F-1073	1	3/8-16 x 2" Capscrew				

CASTER WHEEL ASSEMBLY

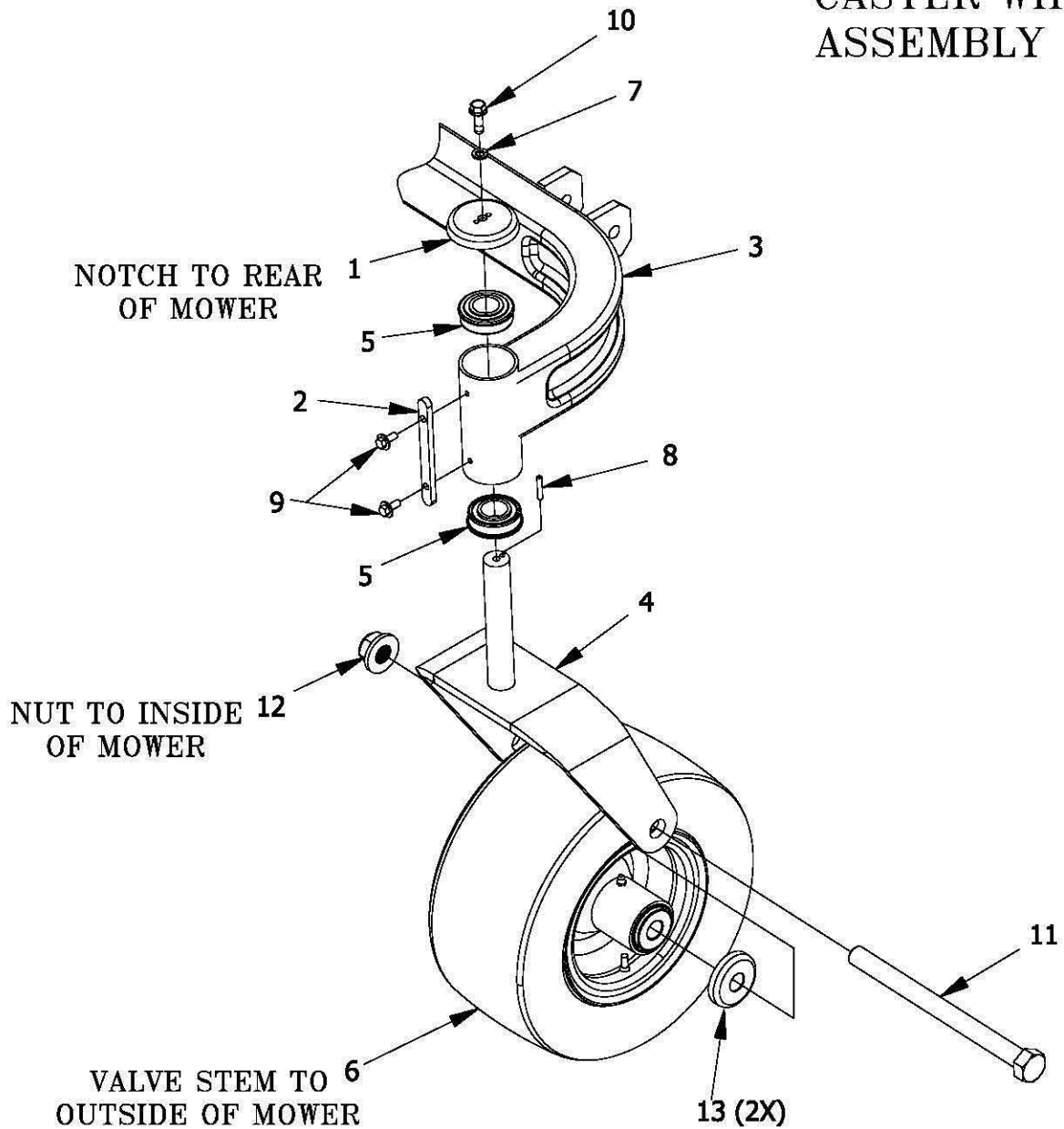

REF NO.	PART NO.	QTY.	DESCRIPTION	REF NO.	PART NO.	QTY.	DESCRIPTION
1	636-176P	2	Bearing Cap	8	F-1855	2	3/16 x 1" Roll Pin (Heavy Duty)
2	659-185P	2	Stop Tab	9	F-2030	4	1/4 x 5/8 Self Tapping Capscrew
3	659-287W	1	WLDT, AXLE, FRONT	10	F-2121	10	FHCS, 5/16-18x1.00, YZ, LOCK PATCH, GR5
4	663-217W	2	WLD'T, CASTER YOKE	11	F-2194	2	HHCS, 3/4-10 X 9-1/2", YZ, GR5
5	D-2008-02	4	Bearing SF-16-32	12	F-2195	2	NUT, FLANGE NYLOC, YZ
6	D-3936	2	TIRE ASS'Y, WHITE, SMOOTH, 13X6.5-6	13	663-221P	2	CAP FOR BEARINGS
7	F-1019-02	2	5/16" LockWasher				

FRAME SIDES & RELATED PARTS

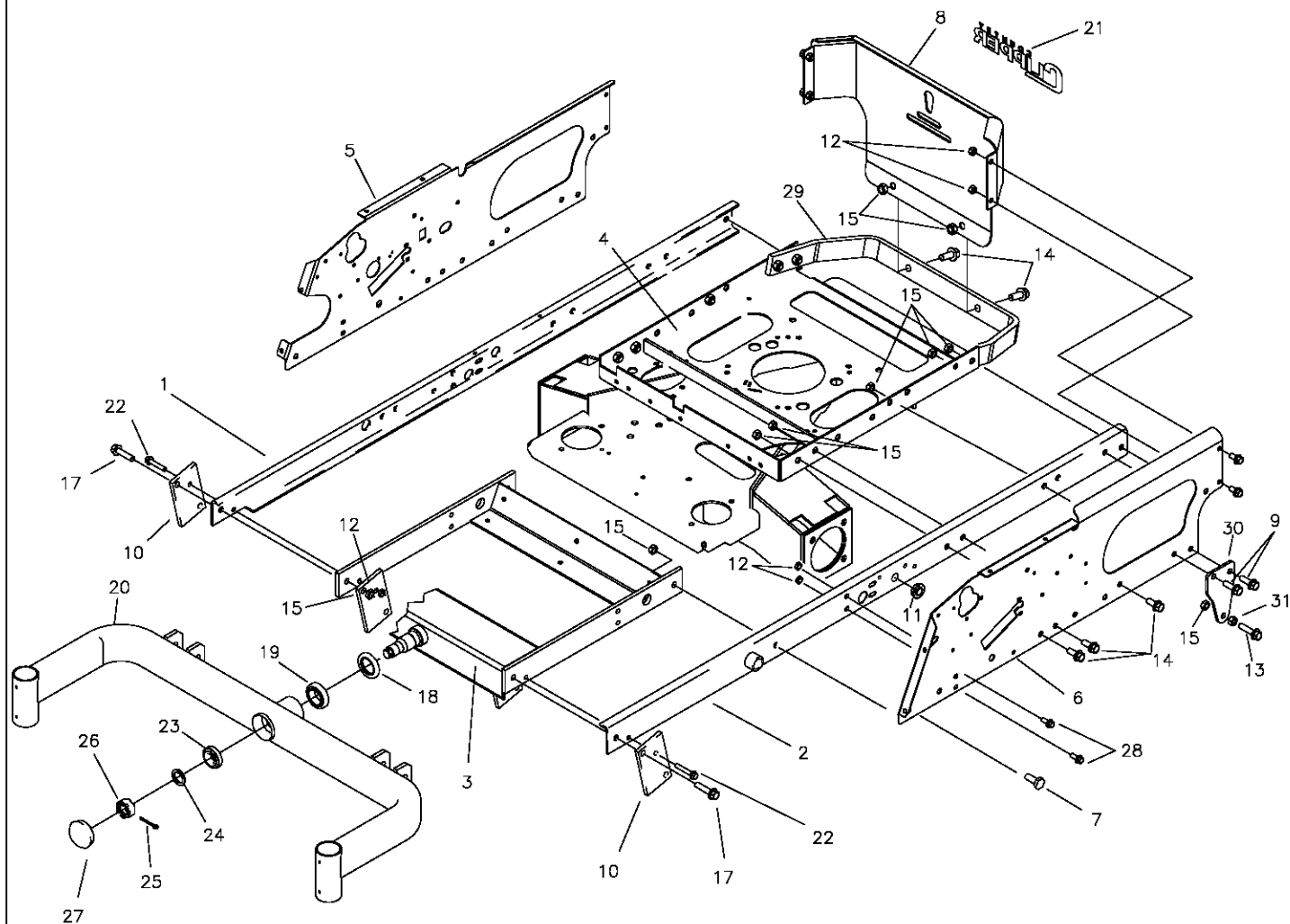

REF NO.	PART NO.	QTY.	DESCRIPTION	REF NO.	PART NO.	QTY.	DESCRIPTION
1	663-185W	1	FRAME SIDE RH.	16	F-2124	4	FHCS, 3/8-16 X 3/4" GR.5
2	663-187W	1	FRAME SIDE LH.	17	F-2128	2	FHCS, 1/2-13 X 2", GR.5
3	709-157W	1	AXLE MOUNTING WLDT.	18	H-2812	1	SEAL SHAFT
4	663-176W	1	MOTOR MOUNT WLDT.	19	D-3825	1	BEARING, TAPARED SET
5	663-188P	1	SIDE PANEL RH. (JOYSTICK)	20	642-189W	1	FRONT AXLE WELDMENT
-	663-195P	1	SIDE PANEL RH. (TWINSTICK)	21	P-12986	1	DECAL, NEW CC, CHROME, LG
6	663-189P	1	SIDE PANEL LH. (JOYSTICK)	22	F-2126	2	FHCS, 3/8-16 x 2" GR.5
-	663-196P	1	SIDE PANEL LH. (TWINSTICK)	23	D-3826	1	BEARING, TAPARED SET
7	F-1386	2	1/2-13 X 1-1/4" GR.5	24	606-303P	1	1" WASHER
8	707-098A	1	ENGINE GUARD w/DECAL	25	F-1728	1	3/16 X 2" COTTER PIN
9	F-2140	4	FHCS, 1/2-13 x 1-1/2" GR.5	26	F-1724	1	1-14 SLOTTED NUT
10	642-063P	2	DRAG BAR TAB	27	H-1924	1	GREASE CAP
11	H-2773	2	BEARING, FLG-SPHERICAL, IGUS	28	F-2125	4	FHCS, 3/8-16 x 1-1/4", YZ, GR5
12	F-2151	10	NUT, 3/8-16, NYLOC FLANGED	29	707-003P	1	GUARD, BUMPER
13	F-2128	1	FHCS, 1/2-13 x 2 GR.5	30	663-120P	1	PLATE, SPRING MOUNT
14	F-2127	15	FHCS, 1/2-13 X 1-1/4" GR.5	31	F-1011-05	1	HEX NUT, 1/2-13
15	F-2152	18	NUT, 1/2-13, NYLOC FLANGED				

FENDER ASSEMBLY & RELATED PARTS

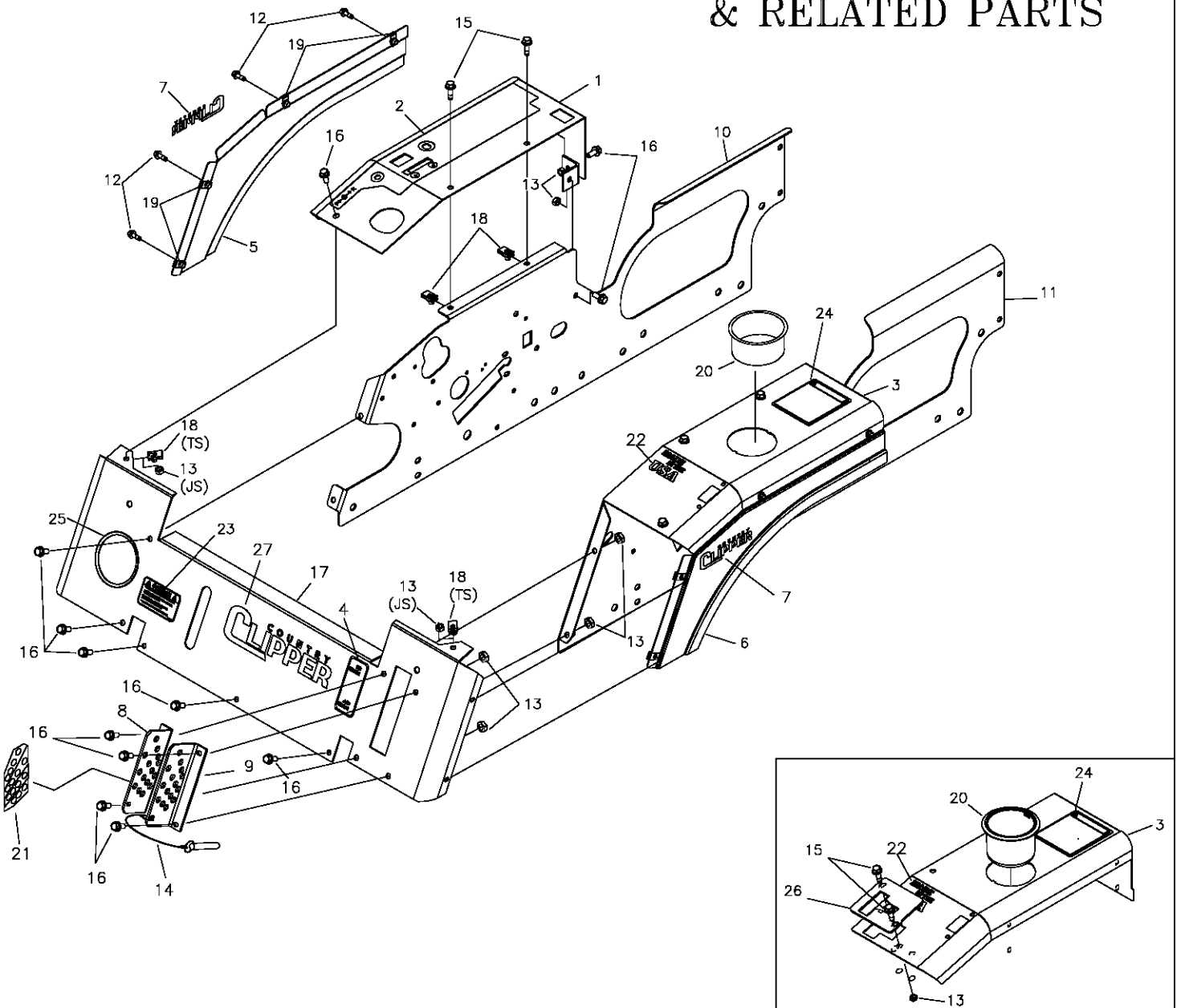

TWINSTICK FENDER ASSY

REF NO.	PART NO.	QTY.	DESCRIPTION	REF NO.	PART NO.	QTY.	DESCRIPTION
1	629-840A	1	FENDER CAP w/DECAL, RH, (JS)	12	F-2119	8	FHCS, 1/4-20x3/4", GR.5 w/PATCH
-	629-892A	1	FENDER CAP w/DECAL, EFI, RH, (JS)	13	F-1125	13	5/16-18 LOCK NUT
-	629-842A	1	FENDER CAP w/DECAL, RH, (TS)	14	629-854A	1	LOCK PIN, DECK HEIGHT, ASS'Y
-	629-893A	1	FENDER CAP w/DECAL, EFI, RH, (TS)	15	F-2121	8	FHCS, 5/16-18x1" GR.5 w/PATCH
2	P-12925	1	DECAL, CONTROL PANEL	16	F-2120	15	FHCS, 5/16-18 X 3/4" GR.5
-	P-13172	1	DECAL, CONTROL PANEL, EFI	17	707-100A	1	FRONT PANEL w/DECALS
3	629-841A	1	FENDER CAP w/DECAL, LH (JS)	18	F-1860	6	5/16-18 "U"-NUT
-	629-843A	1	FENDER CAP w/DECAL, LH (TS)	19	F-1858	8	1/4-20 "U"-NUT
4	P-11382	1	DECAL, PARK BRAKE	20	H-2228	1	CUP HOLDER
5	629-890A	1	FENDER SKIRT w/DECAL, RH	21	P-12034	1	DECAL, "CUT HEIGHT"
6	629-891A	1	FENDER SKIRT w/DECAL, LH	22	P-13000	1	DECAL, "USA"
7	P-12991	2	DECAL, NEW CC, SM, CHROME	23	P-12557	1	DECAL, "CAUTION"
8	647-097A	1	LATCH PLATE RH W/DECAL	24	P-11370	1	DECAL, WARNING
9	647-095P	1	LATCH PLATE LH.	25	H-1626	1	U CHANNEL TRIM
10	-----	1	SEE PAGE 11	26	659-262P	1	NEUTRAL PLATE
11	-----	1	SEE PAGE 11	27	P-12986	1	DECAL, NEW CC, LG, CHROME

SEAT, FOOTDECK & RELATED PARTS

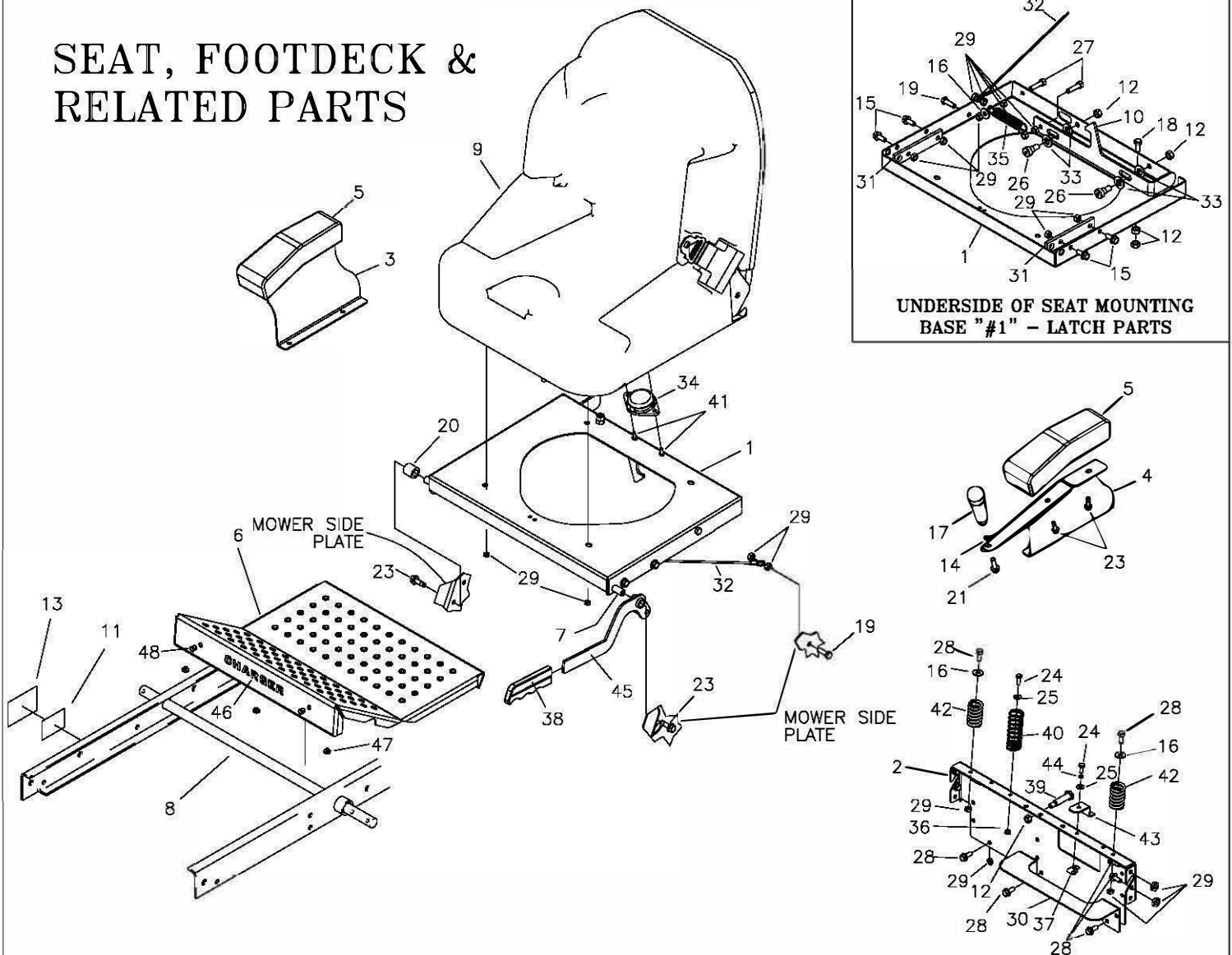

REF NO.	PART NO.	QTY.	DESCRIPTION	REF NO.	PART NO.	QTY.	DESCRIPTION
1	663-194P	1	PLATE, SEAT	24	F-2162	1	FHCS, 1/4-20 X 3/4", GR5, YZ
2	663-197P	1	PLT, REAR SEAT FILLER	25	F-1009-01	2	1/4" FLAT WASHER
3	707-047P	1	PLATE, ARM REST RH	26	F-2062	2	1/2"x3/8 SHOULDER BOLT, SOCKET
4	707-070P	1	PLATE, ARM REST LH (JOYSTICK)	27	F-2122	2	FHCS, 5/16-18 X 1-1/4 YZ, GR5
-	707-048P	1	PLATE, ARM REST LH (TWINSTICK)	28	F-2120	10	FHCS, 5/16-18x3/4" GR5
5	H-2763	2	PAD, ARM REST	29	F-2063	20	NUT, 5/16-18, NYLOC FLANGED
6	629-846A	1	FOOT DECK w/DECAL, CHARGER	30	707-066P	1	SHELF, REAR, FUEL TANK
7	707-043P	1	PIN, SEAT HINGE	31	707-045P	2	BAR, REINFORCEMENT, SEAT
8	620-051P	1	LIFT BAR	32	H-2460	1	CABLE
9	H-2755	1	SEAT	33	F-1521	4	1/2" WASHER
-	H-2910	1	COVER FOR SEAT H-2755	34	E-6374	1	SEAT SWITCH
10	663-081P	1	PLATE, LATCH SLIDE LONG	35	H-1635	1	3/4x4" EXTENSION SPRING
11	P-13142	1	SERIAL TAG	36	F-2132	1	NUT, 1/4-20, NYLOC FLANGED
12	F-1005-03	7	3/8-16 LOCK NUT	37	F-1858	1	1/4-20 "U" NUT
13	P-12473	1	SERIAL TAG LAMINATION DECAL	38	H-1926	1	HANDLE, GRIP
14	F-1486	1	3/8-16 JAM NUT	39	F-2061	1	1/2"x1 1/2" SHOULDER BOLT
15	F-2120	4	FHCS, 5/16-18x3/4" GR5	40	H-2608	1	SPRING, ASSIST
16	F-1009-02	3	5/16 FLAT WASHER	41	F-1785	2	SCREW, HX WASHER HD #14 X 3/4"
17	H-2764	1	HANDLE, JOYSTICK	42	H-2636	2	SPRING, CMPR, SEAT CHARGER
18	F-2141	1	FHCS, 3/8-16 X 1", YZ, GR5	43	659-137P	1	BATTERY HOLD DOWN
19	F-2148	2	FHCS, 5/16-18 X 1" YZ GR5	44	F-1019-01	1	1/4" LOCK WASHER
20	707-046P	1	SPACER, SEAT PAN	45	663-205W	1	WLDT, BRAKE HANDLE
21	F-2125	1	FHCS, 5/16-18x1-1/4" GR5	46	P-12982	1	DECAL, CHARGER, CHROME
22	F-2063	4	3/8-16 NYLOC NUT, FLANGED	47	H-2461	3	RUBBER BUMPER
23	F-2121	6	FHCS 5/16-18x1" w/PATCH	48	H-1280	2	PLASTIC PLUG

FRONT STEP ASSEMBLY

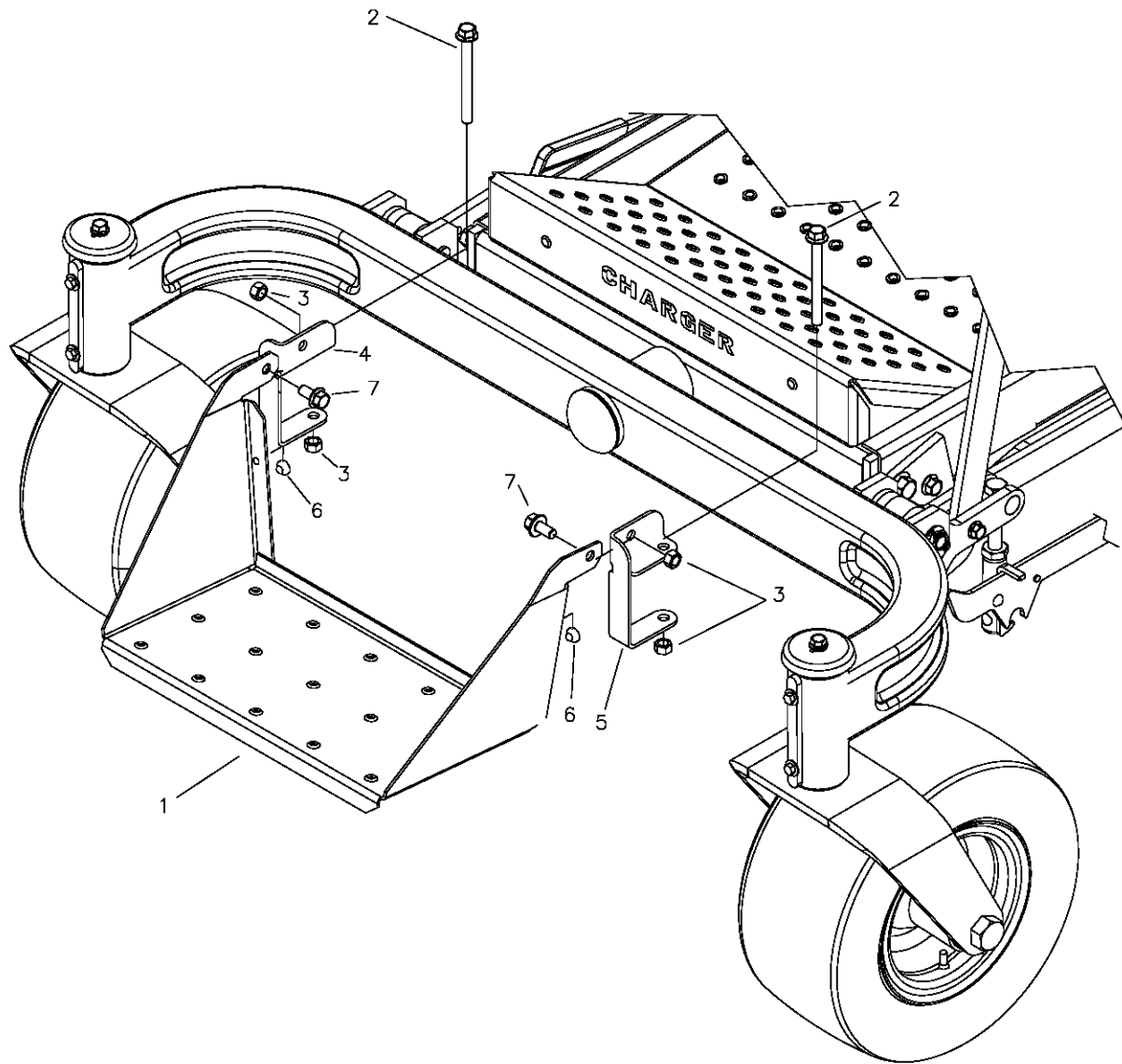

REF NO.	PART NO.	QTY.	DESCRIPTION
1	663-134P	1	FRONT STEP
2	F-2142	2	FHCS, 3/8-16 X 4" GR.5
3	F-2151	4	NUT, 3/8-16, NYLOC FLANGED
4	659-241P	1	BRACKET, STEP MOUNT, RH
5	659-242P	1	BRACKET, STEP MOUNT, LH
6	H-2461	2	RUBBER BUMPER BUTTON
7	F-2124	2	FHCS, 3/8-16 X 3/4" GR.5

ROPS ASSEMBLY (H-2682) AND RELATED PARTS

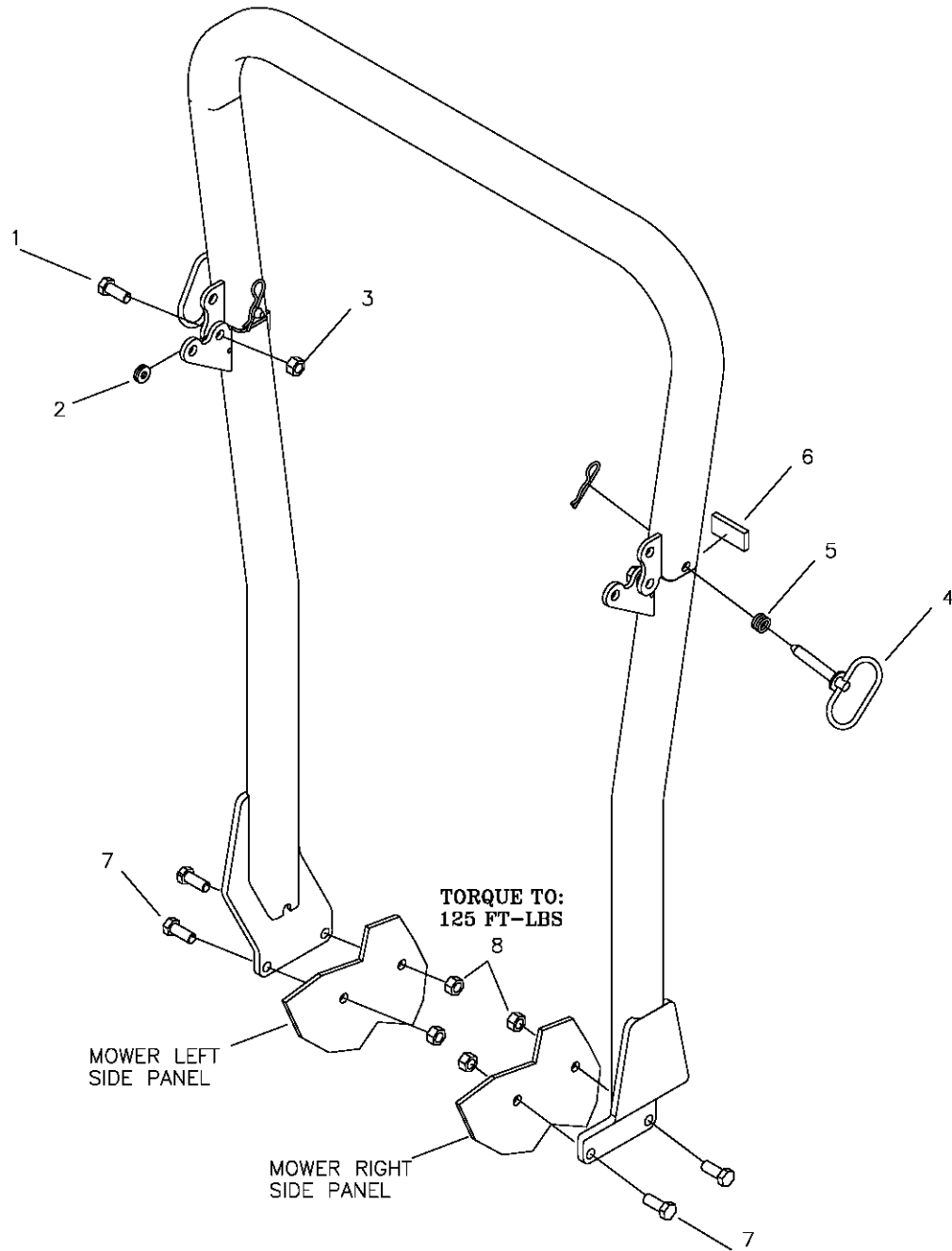

REF NO.	PART NO.	QTY.	DESCRIPTION
1	F-2088	2	HHCS 1/2-13 x 1 1/4"
2	F-2089	2	FLAT WASHER 1/2"φ
3	F-2090	2	TOP LOCK NUT 1/2"φ
4	F-2093	2	PULL PIN-1/2 W/COTTER KEY
5	H-2701	2	SPRING
6	H-2700	2	POLYURETHANE CHANNEL
7	F-2091	4	HHCS 1/2-13 x 1 1/2"
8	F-2092	4	NLN 1/2-13 GR 8

FUEL TANK ASSEMBLY H-2725

(INCLUDES ALL PARTS EXCEPT #2)

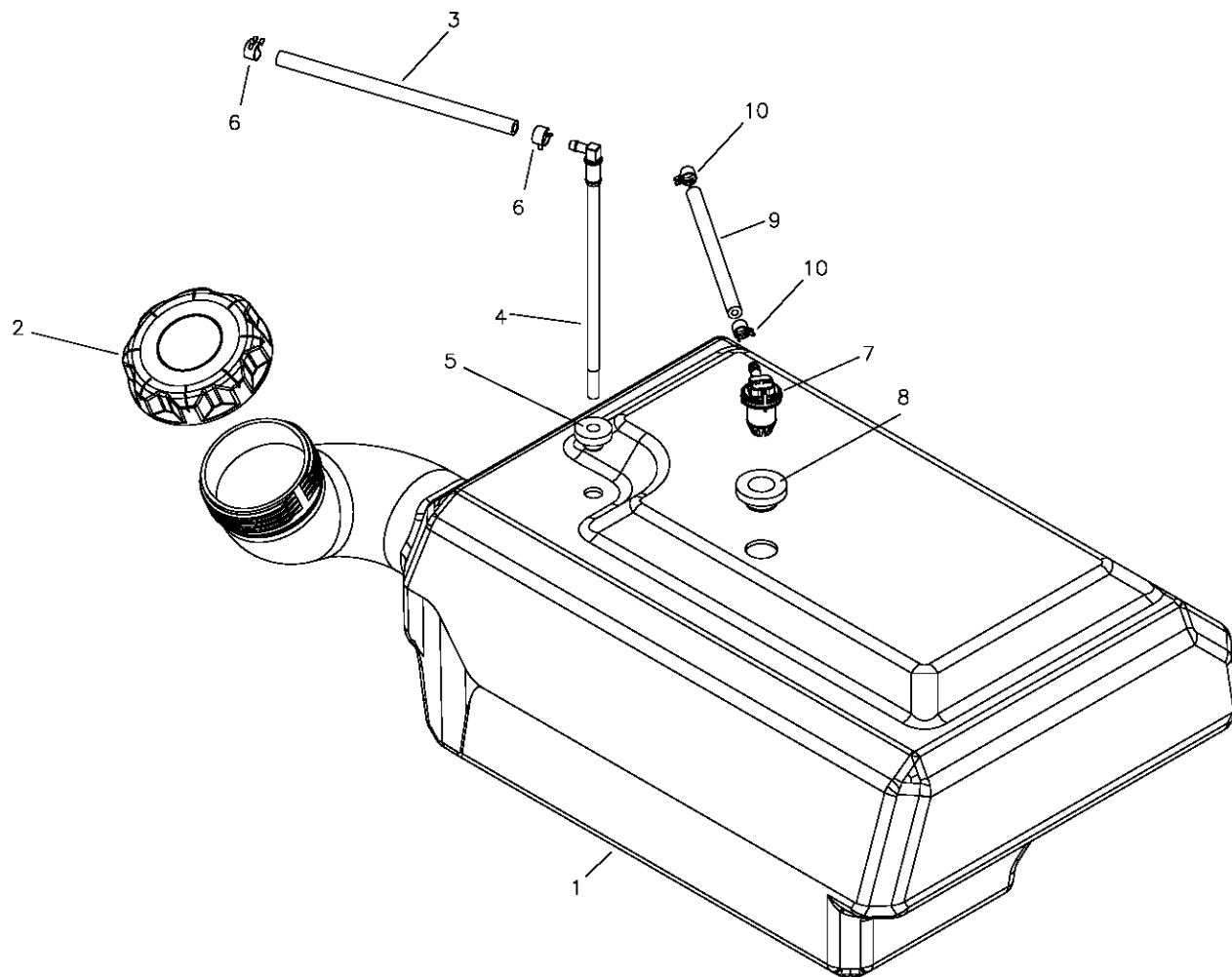

REF NO.	PART NO.	QTY.	DESCRIPTION
1	-----	-	8 GALLON TANK, VENTED
2	H-2743	1	GAS CAP, RATCHET
3	H-1648	4.0ft	FUEL LINE
4	H-2742	1	PICK UP TUBE
5	H-2741	1	GROMMET, PICK UP TUBE
6	H-1687	2	HOSE CLAMP, 1/2"
7	H-2678	1	REMOTE VENT
8	H-2679	1	REMOTE VENT GROMMET
9	H-2697	4.0ft	VENT LINE
10	H-2698	2	VENT LINE CLAMP

JOYSTICK STEERING CONTROL AND RELATED PARTS

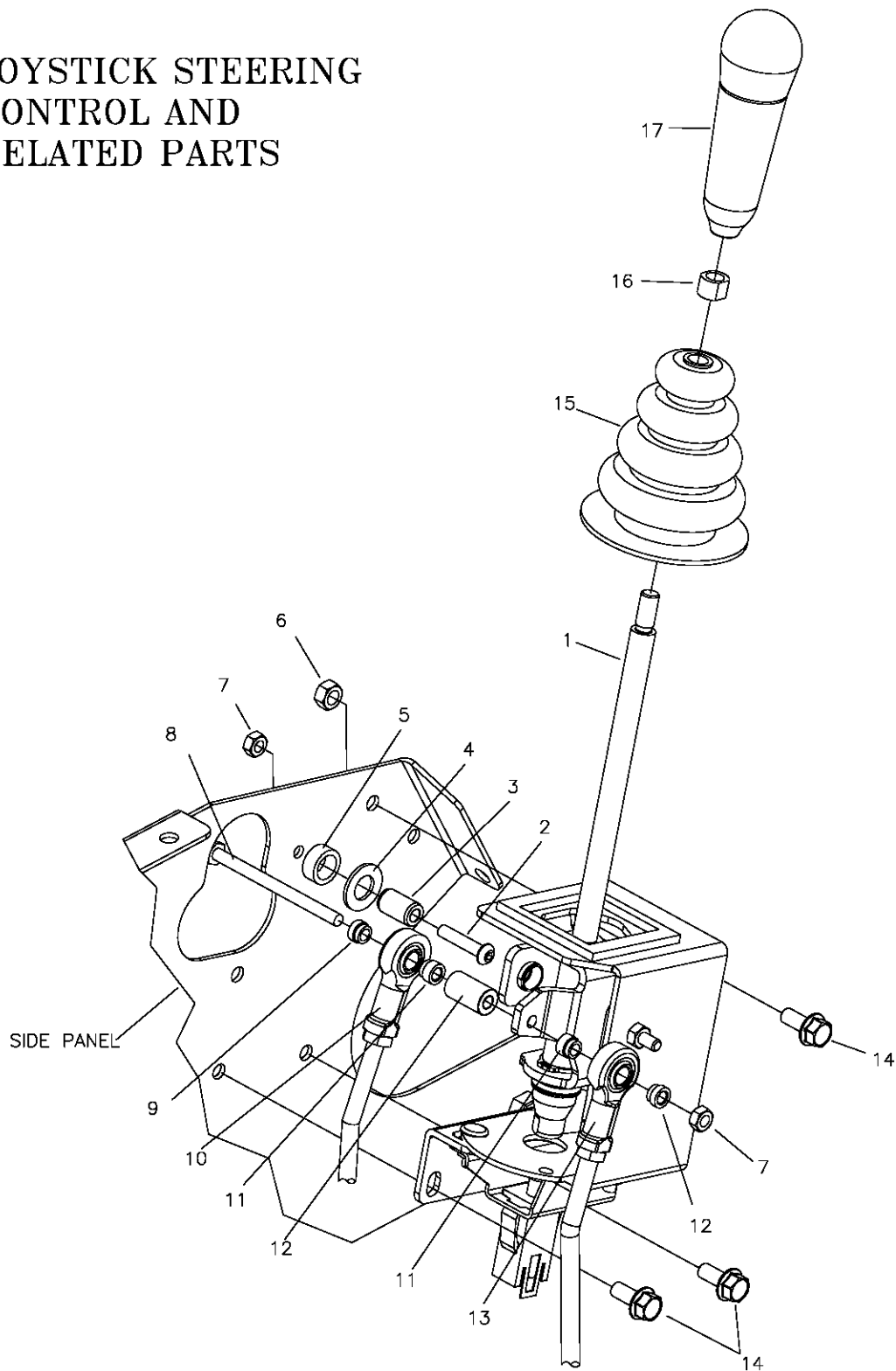

REF NO.	PART NO.	QTY.	DESCRIPTION	REF NO.	PART NO.	QTY.	DESCRIPTION
1	625-121A	1	JOYSTICK ASSEMBLY	10	707-082P	1	LINKAGE, INNER, JOYSTICK
2	F-2103	1	BUTTON SHCS, 1/4-20x1"	11	625-107P	1	BUSHING, .375 ROD END
3	625-119P	1	PIN, PIVOT, JS, LONG	12	625-100P	1	TUBE, PIVOT, JOYSTICK
4	F-1521	1	1/2" WASHER	13	707-083P	1	OUTER, LINKAGE, JOYSTICK
5	625-126P	1	SPACER, JOYSTICK PANEL	14	F-2120	3	FHCS, 5/16-18 x 3/4" GR5
6	F-2063	3	NUT, 5/16-18, NYLOC FLANGED	15	H-1991	1	BOOT
7	F-2132	2	NUT, 1/4-20, NYLOC FLANGED	16	H-2765	1	NUT, JOYSTICK
8	F-1020-01	1	1/4-20 x 3-1/2" CAPSCREW	17	H-2764	1	HANDLE, JOYSTICK
9	625-116P	1	BUSHING, .375 ROD END, SHORT				

JOYSTICK ASSEMBLY 625-121A

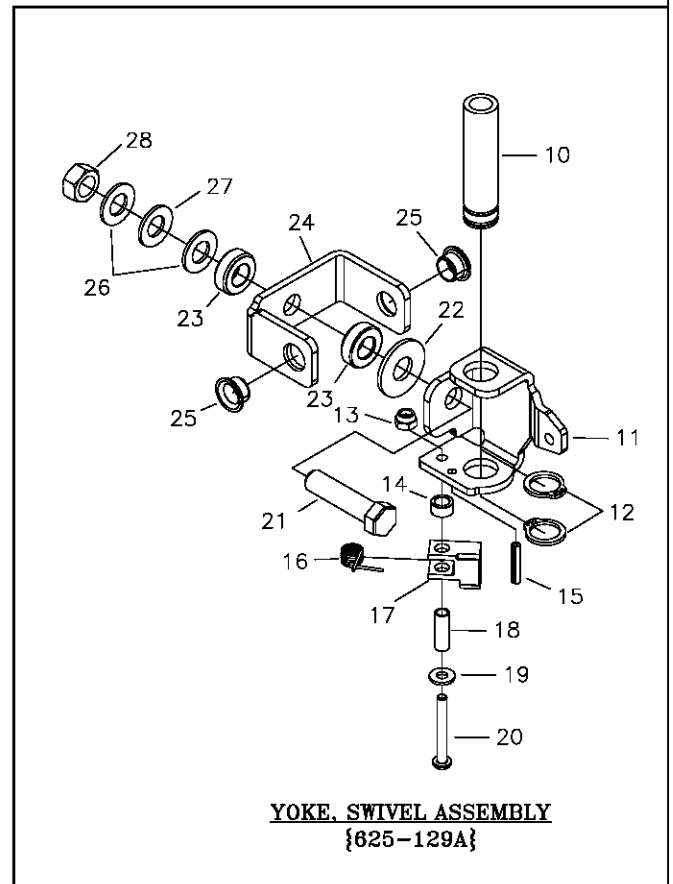
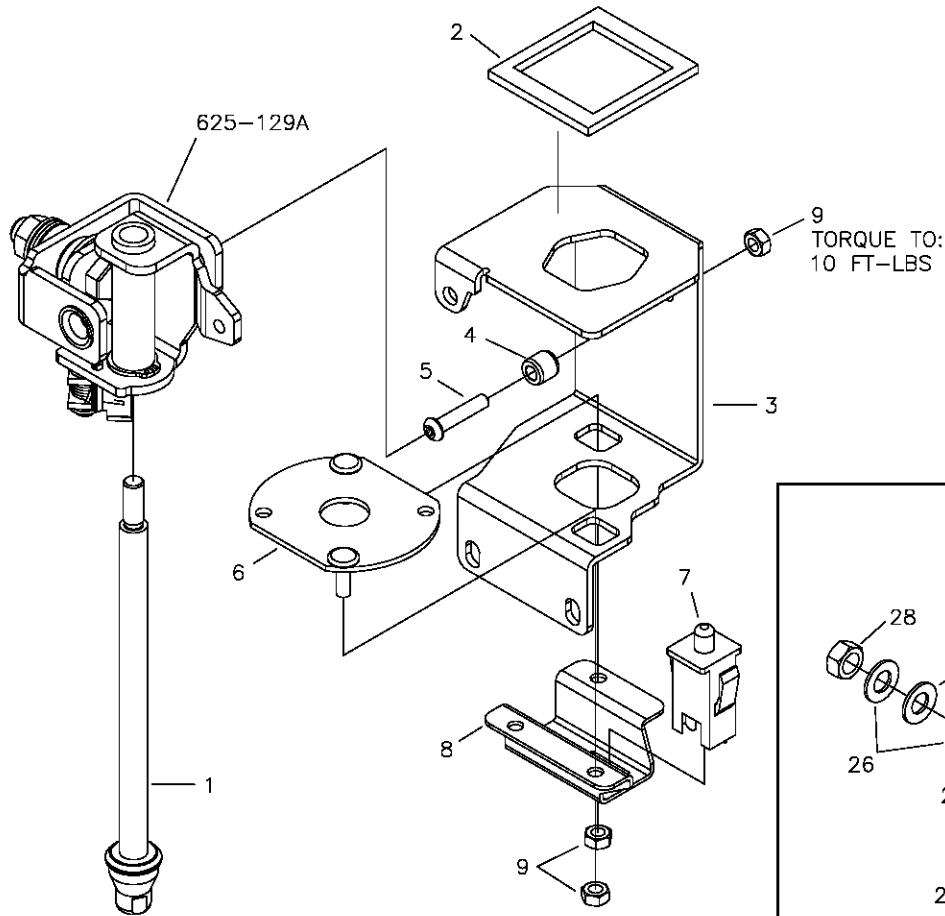

ITEM	PART #	QTY.	DESCRIPTION	ITEM	PART #	QTY.	DESCRIPTION
1	625-130A	1	ROD ASSEMBLY, SHORT	15	F-1503	1	3/16 x 1" SPIRAL PIN
2	H-1947	1	GASKET, FOAM, JOYSTICK	16	H-2710	1	SPRING, DETENT, JOYSTICK
3	625-095P	1	HOUSING, JOYSTICK	17	625-103P	1	TAB, CAM DETENT
4	625-106P	1	PIN, PIVOT, JOYSTICK	18	625-124P	1	TUBE-SPACER, DETENT CAM
5	F-2103	1	BUTTON SHCS, 1/4-20 x 1", CZ	19	F-2136	1	WASHER, FLAT, #12 PLAIN
6	625-127W	1	NEUTRAL PLATE, WLDT	20	F-2135	1	SCR, PANHD, PHLPS, #12-24x1-3/4"
7	E-6474	1	SWITCH, SNAP MOUNT	21	F-1293	1	1/2-13 x 2" CAPSCREW
8	659-285P	1	MOUNT, SWITCH	22	F-1009-05	1	1/2" FLAT WASHER
9	F-1005-01	3	1/4-20 LOCK NUT	23	D-3857	2	THRUST BEARING
10	625-099P	1	TUBE, GUIDE, CONTROL ROD	24	625-097P	1	PIVOT, JOYSTICK (PART OF 625-128A)
11	625-096P	1	YOKE, SWIVEL, JOYSTICK	25	D-3784	2	BUSHING, FLANGED (PART OF 625-128A)
12	H-2705	2	RING, DETENT, .75 EXT.	26	F-1521	2	1/2" WASHER, CUSTOM
13	F-2137	1	NUT, #12-24, NYLOCK	27	H-2704	1	SPRING, BELLEVILLE, .50x1x.073
14	625-125P	1	SPACER, CAM DETENT	28	F-1005-05	1	1/2-13 STOVER NUT

JOYSTICK STEERING CONTROL AND RELATED PARTS (CON'T)

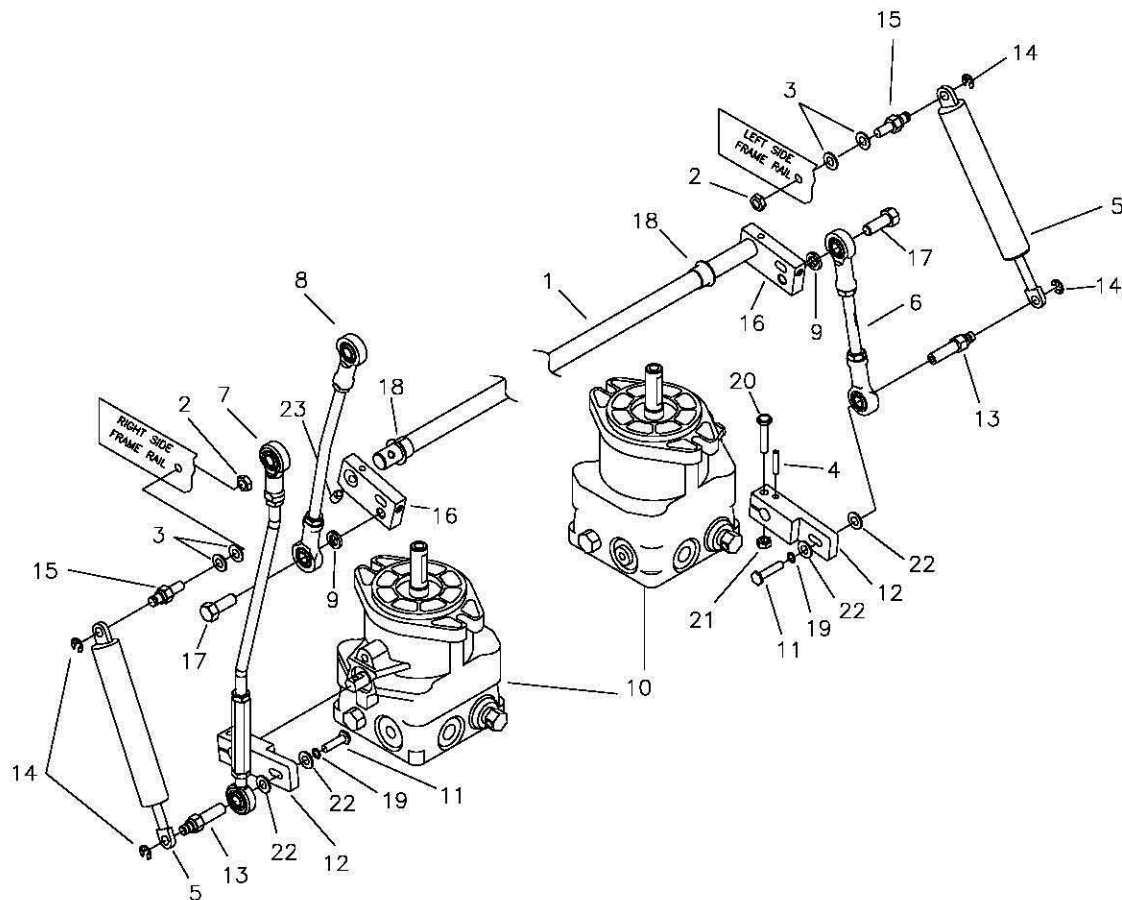

REF NO.	PART NO.	QTY.	DESCRIPTION	REF NO.	PART NO.	QTY.	DESCRIPTION
1	700-150P	1	HYDRO SHIFT ROD	13	663-051P	2	DAMPNER BOLT, FEMALE
2	F-2063	2	NUT, 5/16", NYLOC FLANGED	14	F-1610	4	E-RING
3	F-1009-02	4	5/16" FLAT WASHER	15	638-028P	4	5/16-18 X 3/4" DAMPNER BOLT
4	F-1725	2	5MM x 26MM ROLL PIN	16	700-151P	2	SWIVEL ARM
5	H-2467	2	DUAL ACTION DAMPER, LITE DUTY	17	F-1394	2	3/8-16 X 1" CAPSCREW
6	H-2468	1	LINKAGE, JOYSTICK	18	D-3730	2	BUSHING
7	707-083P	1	OUTER, LINKAGE, JS	19	F-1019-01	2	1/4" LOCK WASHER
8	707-082P	1	LINKAGE, INNER, JS	20	F-1539	2	1/4-20 x 1 1/4" CAPSCREW
9	F-1019-03	2	3/8" LOCK WASHER	21	F-1158	2	1/4-20 STOVER NUT
10	----	-	SEE PAGE 24	22	F-1009-01	4	1/4" FLAT WASHER
11	F-1015-05	2	1/4-20 X 1" BOLT GR 5	23	F-2206	2	SHCS, 12-24 X 1-1/4, ZINC
12	663-135P	2	LEVER, CONTROL				

TWINSTICK STEERING CONTROL & RELATED PARTS

(RIGHTHAND SHOWN, LEFTHAND OPPOSITE)

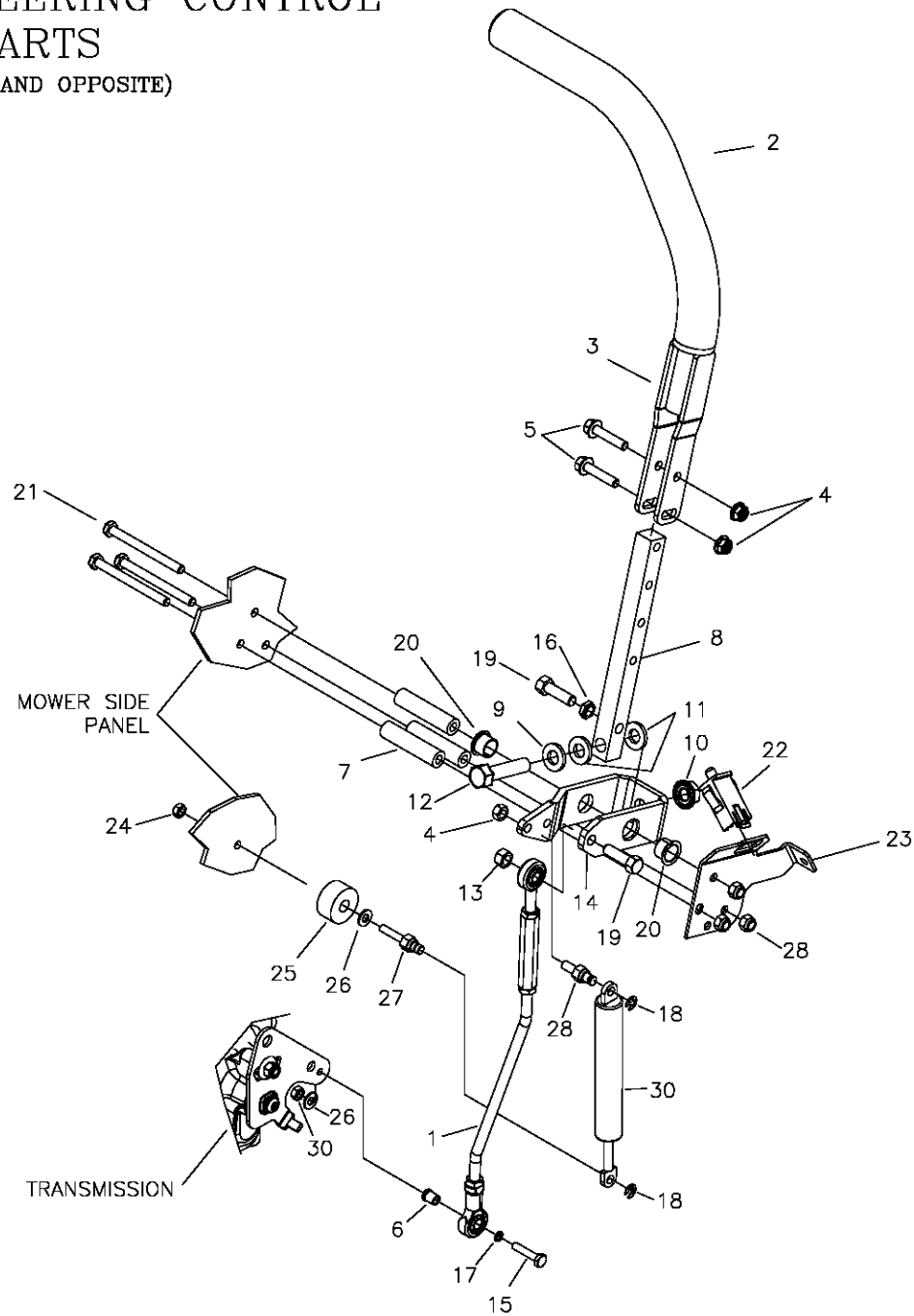

REF NO.	PART NO.	QTY.	DESCRIPTION	REF NO.	PART NO.	QTY.	DESCRIPTION
1	663-050P	1	LINK ROD ASSEMBLY	16	F-1486	1	3/8-16 JAM NUT
2	H-2739	1	GRIP, 15", CLOSED END	17	F-1019-01	4	1/4" LOCK WASHER
3	659-364W	1	DUAL LEVER CONTROL	18	F-1610	2	E-RING FOR 1/4" SHAFT
4	F-2063	8	NUT, 5/16-18, NYLOC FLANGED	19	F-1307	2	3/8-16 X 1 1/4" CAPSCREW
5	F-2129	2	FHCS, 5/16-18 X 1 1/2" w/PATCH	20	D-3730	2	FLANGED BUSHING 5/8" BORE
6	H-2465	1	ADAPTER, ROD END, LONG	21	F-2058	3	5/16-18 x 3 1/2" CAPSCREW
7	659-252P	3	TUBE SPACER	22	E-6474	1	SWITCH, SNAP MOUNT
8	659-365P	1	LOWER SHIFT BLOCK	23	647-242P	1	MOUNTING BRACKET (RH)
9	F-1521	1	WASHER	--	647-243P	1	MOUNTING BRACKET (LH)
10	F-2060	1	1/2-13 NUT, FLANGE LOCK	24	F-2132	1	NUT, 1/4-20, NYLOC FLANGED
11	606-151P	2	WASHER, NYLON 1/2 ID x 1/8"	25	F-2045	1	SPACER
12	F-1293	1	HHCS, 1/2-13 X 2", YZ GR5	26	F-1009-01	2	1/4" FLAT WASHER
13	F-2151	1	NUT, 3/8-16, NYLOC FLANGED	27	638-029P	1	DAMPER BOLT, 1/4-20
14	659-243P	1	SHIFTING YOKE	28	H-2843	1	DUAL ACTION DAMPNER, 750N
15	F-2182	1	FHCS, 1/4-20 X 1-1/4", YZ GR5	29	638-028P	1	DAMPER BOLT, 5/16-18 X 3/4"

PARKING BRAKE ASSEMBLY & RELATED PARTS

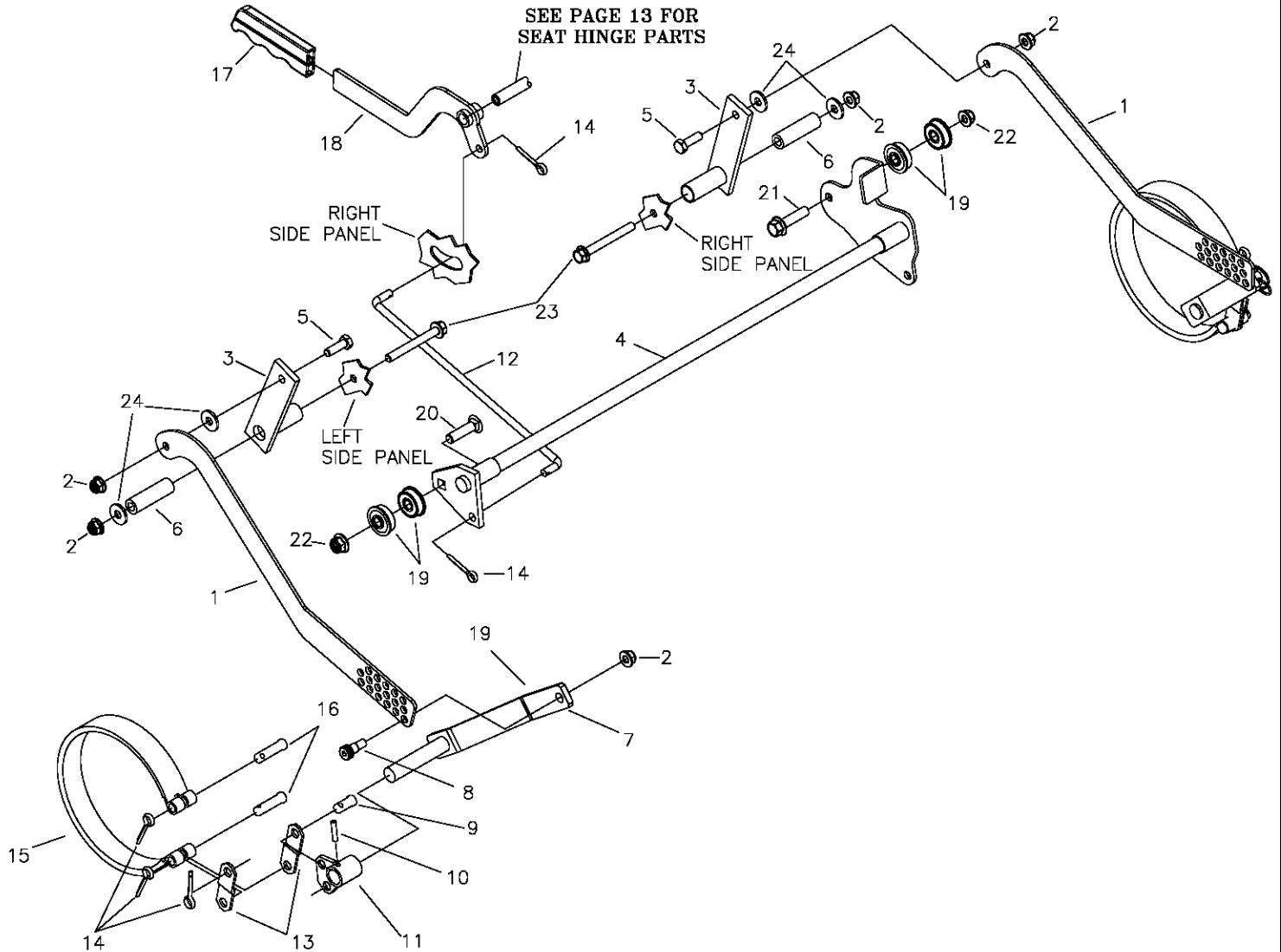

REF NO.	PART NO.	QTY.	DESCRIPTION	REF NO.	PART NO.	QTY.	DESCRIPTION
1	663-165P	2	LINK, ADJUSTABLE, BRAKE	13	647-010P	4	BRAKE ANCHOR LINK
2	F-2063	6	NUT, 1/2" FLANGED, NYLOC	14	F-1491	8	1/8 X 1" COTTER PIN
3	663-166W	2	WLDT, CAM LEVER	15	D-3668	2	BRAKE BAND 6" X 1" WIDE
4	663-169W	1	BRAKE ROD WLDT	16	F-1444	4	3/8 X 1 5/16" CLEVIS PIN
5	F-1015-15	2	5/16-18 X 1" CAPSCREW	17	H-1926	1	GRIP HANDLE
6	663-172P	2	PIN, PIVOT	18	663-205W	1	WLDT, BRAKE HANDLE
7	663-150W	2	BRAKE ARM WLDT	19	D-3911	4	3/8x1-1/8, FLG BALL BEARING
8	F-2173	2	SHOULDER BOLT, .37x.37, SOCKET	20	F-1177	1	3/8-16 X 1-1/2" CARRIAGE BOLT
9	F-1438	2	3/8 X 3/4" CLEVIS PIN	21	F-2147	1	FHCS, 3/8-16 X 1-1/2", YZ, GR5
10	F-1855	2	ROLL PIN, 3/16 X 1" HVY. DUTY	22	F-2151	2	NUT, 3/8", FLANGED, NYLOC
11	647-029W	1	SHORT BRAKE ARM (LH)	23	F-2153	2	FHCS, 5/16-18 X 2-3/4", YZ, GR5
--	647-028W	1	SHORT BRAKE ARM (RH)	24	F-1009-05	4	WASHER, 5/16"
12	663-122P	1	ROD, BRAKE LINK				

GEAR MOTOR, WHEEL ASSEMBLY

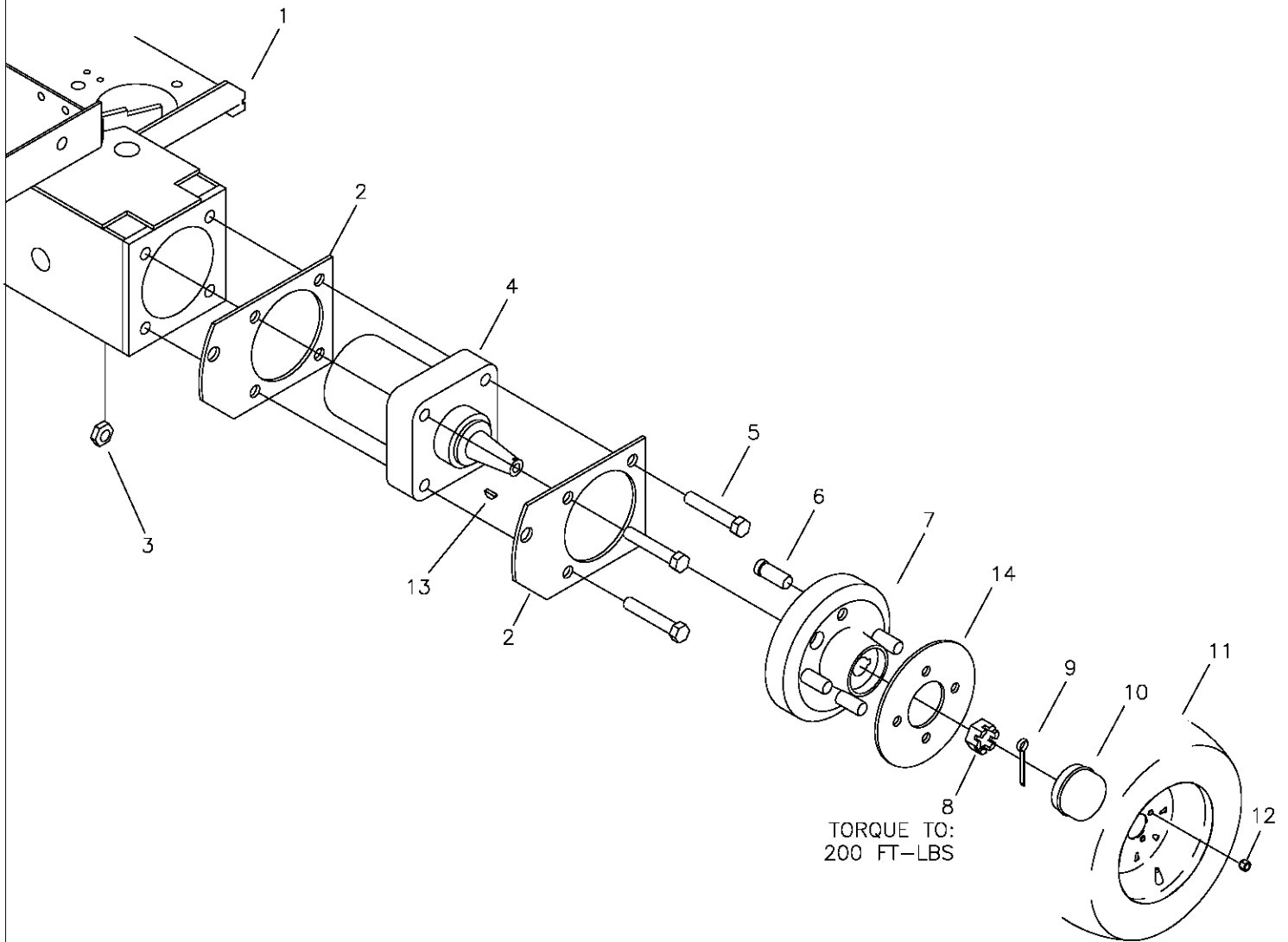

REF NO.	PART NO.	QTY.	DESCRIPTION
1	663-176W	1	MOTOR MOUNT
2	647-017P	4	BRAKE MOUNT
3	F-2152	8	NUT, 1/2-13, NYLOC FLANGED
4	D-3908	2	15.9 CIR PARKER WHEEL MOTOR
5	F-1668	8	1/2-13 X 2 3/4" BOLT GR. 5
6	F-1654	8	WHEEL STUD (REPLACEMENT)
7	663-207A	2	WHEEL HUB
8	F-1909	2	3/4-16 CASTLE NUT
9	H-1376	2	1/8 X 1 1/2" COTTER PIN
10	H-1798	1	GREASE CAP
11	D-3669	2	TIRE/WHEEL ASSEMBLY
12	F-1499	8	LUG NUT 1/2-20 X 60 DEG.
13	D-1004-01	2	1/4 X 1" WOODRUFF KEY
14	659-092P	2	WHEEL BACKING PLATE

MOTOR ASSEMBLY & RELATED PARTS FOR 25.5HP KAWASAKI

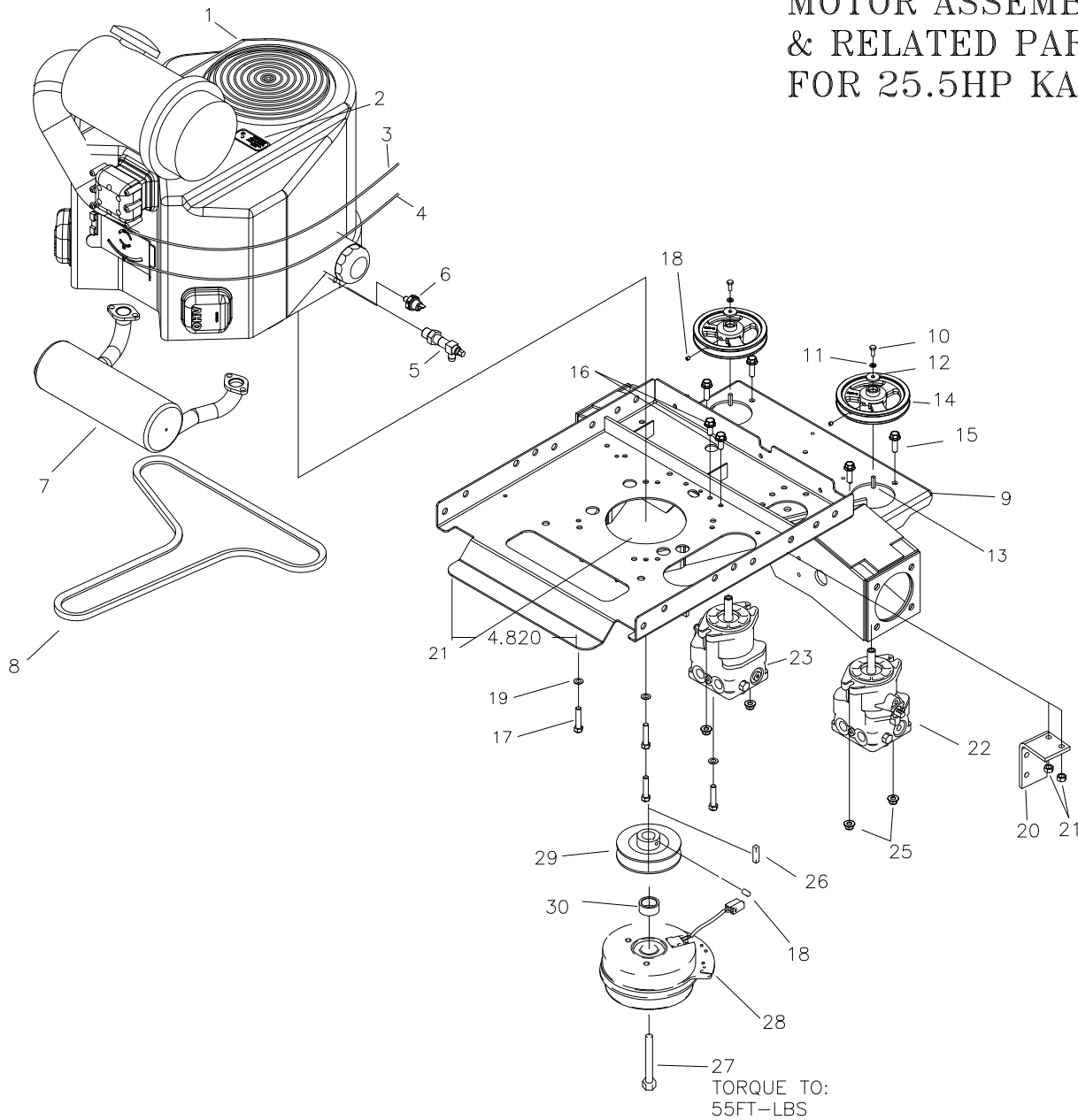

REF NO.	PART NO.	QTY.	DESCRIPTION	REF NO.	PART NO.	QTY.	DESCRIPTION
1	M-5384	1	ENGINE, KAWASAKI, 25.5HP	16	F-2120	2	FHCS, 5/16-18 X 3/4" GR5
2	P-10077	1	DECAL, "CLEAN"	17	F-2125	4	FHCS, 3/8-16x1-1/4", YZ, GR5
3	H-2287	1	CHOKE CABLE	18	F-1228	3	1/4-20 NYLOC SETSCREW
4	H-2610	1	THROTTLE CABLE	19	F-1019-03	4	3/8" LOCK WASHER
5	H-2590	1	OIL DRAIN	20	707-033P	1	CLUTCH STOP
6	E-6307	1	OIL PRESSURE SWITCH	21	F-2063	2	NUT, 5/16-18, NYLOC FLANGED
7	H-2850	1	MUFFLER (KAWASAKI)	22	D-3907-01	1	PUMP, 12CC, RH
8	D-3524	1	V-BELT A-71 KEVLAR	23	D-3907-02	1	PUMP, 12CC LH
9	663-176W	1	MOTOR MOUNT	24	F-1009-03	8	3/8" FLAT WASHER
10	F-1737	2	6mm X 16mm BOLT GR. 5	25	F-2151	4	NUT, 3/8-16, NYLOC FLANGED
11	F-1738	2	6mm SPRING WASHER	26	621-113P	1	KEY, 1/4" SQ. X 1 1/4"
12	F-1736	2	WASHER, .840 X .246 X .125	27	F-2113	1	7/16-20x2-1/2" CAPSCREW, GR8
13	D-3541	2	KEY - 5mm x 20mm	28	E-6532	1	1 1/8" CLUTCH BRAKE
14	647-147P	2	HYDRO PUMP PULLEY	29	647-148P	1	MOTOR PULLEY
15	F-2125	4	FHCS, 3/8-16 X 1 1/4" GR5	30	F-2043	1	SPACER

MOTOR ASSEMBLY & RELATED PARTS FOR 26HP EFI KOHLER

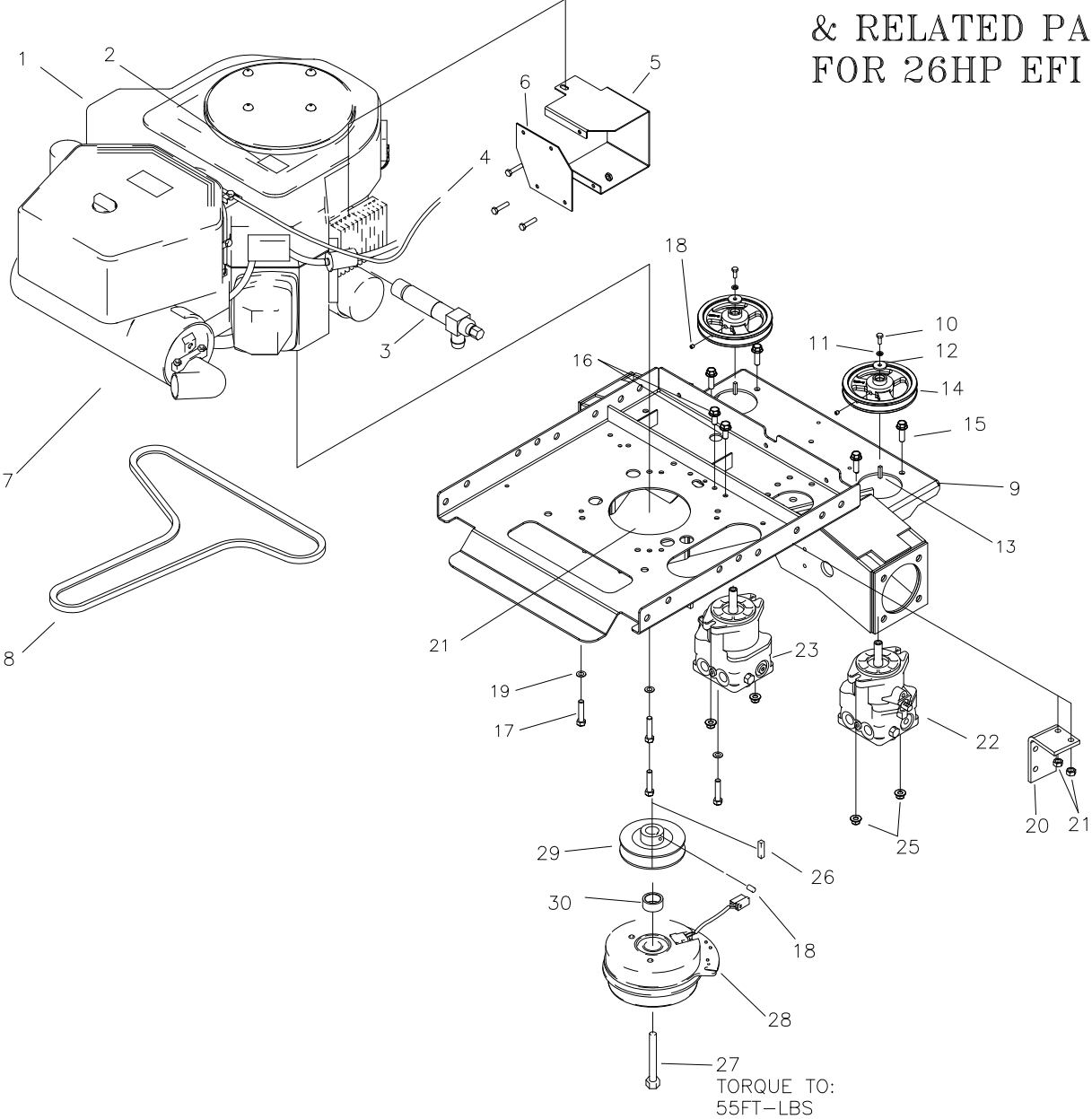

REF NO.	PART NO.	QTY.	DESCRIPTION	REF NO.	PART NO.	QTY.	DESCRIPTION
1	M-5396	1	ENGINE KOHLER, 26.5HP EFI	17	F-2040	4	HFCS, 3/8-16x1-1/2", THRD FORM
2	P-10077	1	DECAL, "CLEAN"	18	F-1228	3	1/4-20 NYLOC SETSCREW
3	H-2589	1	OIL DRAIN (KOHLER)	19	F-1019-03	4	3/8" LOCK WASHER
4	H-2610	1	THROTTLE CABLE	20	707-033P	1	CLUTCH STOP
5	663-221P	1	PLATE, DEFLECTOR EFI	21	F-2063	2	NUT, 5/16-18, NYLOC FLANGED
6	663-222P	1	PLATE, DEFLECTOR COVER	22	D-3907-01	1	PUMP, 12CC, RH
7	H-2851	1	MUFFLER	23	D-3907-02	1	PUMP, 12CC LH
8	D-3524	1	V-BELT A-71 KEVLAR	24	F-1009-03	8	3/8" FLAT WASHER
9	663-176W	1	MOTOR MOUNT	25	F-2151	4	NUT, 3/8-16, NYLOC FLANGED
10	F-1737	2	6mm X 16mm BOLT GR. 5	26	621-113P	1	KEY, 1/4" SQ. X 1 1/4"
11	F-1738	2	6mm SPRING WASHER	27	F-2113	1	7/16-20x2-1/2" CAPSCREW, GR8
12	F-1736	2	WASHER, .840 X .246 X .125	28	E-6532	1	1 1/8" CLUTCH BRAKE
13	D-3541	2	KEY - 5mm x 20mm	29	647-148P	1	MOTOR PULLEY
14	647-147P	2	HYDRO PUMP PULLEY	30	F-2043	1	SPACER (KAWASAKI)
15	F-2125	4	FHCS, 3/8-16 X 1 1/4" GR5	31	F-2100	3	HEX M/S (ZINC) 10-32 X 7/8
16	F-2120	2	FHCS, 5/16-18 X 3/4" GR5	32	F-1448	3	LOCKNUT, 10-32 NYLOC YELLOW PLTD

**PLUMBING KIT
HIGH PRESSURE
LINES & FITTINGS
{H-2846}**

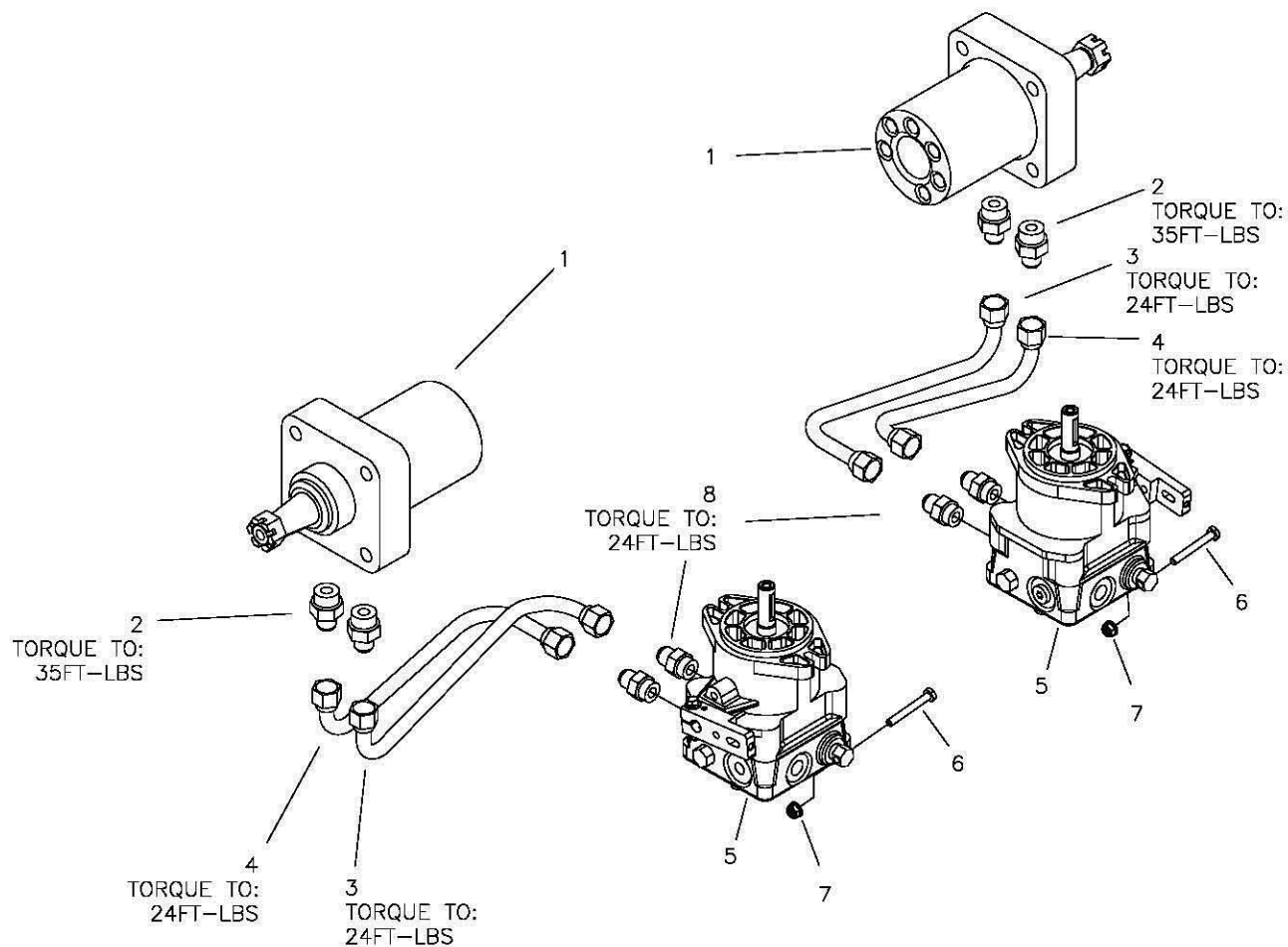

VIEWED FROM FRONT RIGHT

REF NO.	PART NO.	QTY.	DESCRIPTION
1	D-3908	2	WHEEL MOTOR
2	H-2319	4	FITTING, STRIGHT, 7/8-14
3	H-2491	2	TUBE ASS'Y, LH. FORWARD
4	H-2492	2	TUBE ASS'Y, LH. REVERSE
5	-----	-	SEE PAGE 24
6	F-1015-09	2	1/4-20 X 2" BOLT GR. 5
7	F-2132	2	NUT, 1/4-20, NYLOC FLANGED
8	H-2436	4	FITTING, STRAIGHT, 3/4" X 1/2"

PLUMBING KIT OIL RETURN LINES & COOLER ASSEMBLY {H-2846}

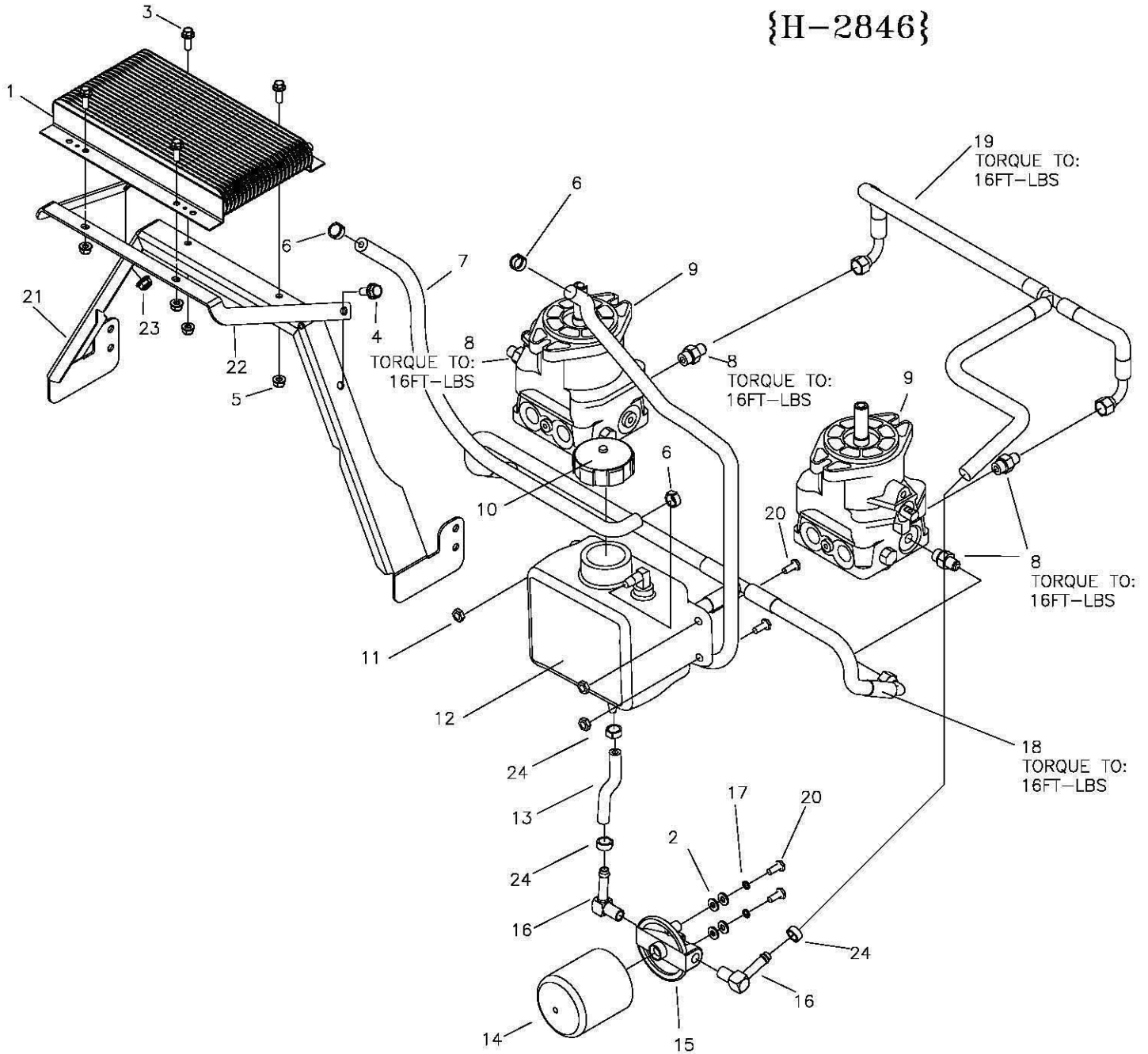

REF NO.	PART NO.	QTY.	DESCRIPTION	REF NO.	PART NO.	QTY.	DESCRIPTION
1	H-2908	1	OIL COOLER	13	H-2847	1	20" HOSE, 3/8 id. HI TEMP.
2	F-1009-01	8	1/4" WASHER	14	H-2859	1	OIL FILTER
3	F-2162	6	FHCS, 1/4-20x3/4", YZ, GR5	15	H-2858	1	FILTER BASE
4	F-2120	2	FHCS, 5/16-18x3/4", YZ, GR5	16	H-2860	1	HOSE BARB 90 DEG. ELBOW
5	F-2132	4	NUT, 1/4-20, FLANGED NYLOC	17	F-1019-01	2	1/4" LOCK WASHER
6	H-2282	3	HOSE CLAMP	18	H-2849	1	RETURN HOSE TEE ASSEMBLY
7	H-2438	1	24" HOSE, 3/8" ID. HI TEMP.	19	H-2848	1	SUCTION HOSE TEE ASSEMBLY
8	H-2330	4	9/16" ADAPTER	20	F-1015-15	4	5/16-18 x 1" CAPSCREW
9	-----	-	SEE PAGE 24	21	663-202P	1	BRACKET, COOLER
10	H-2917	1	CAP, 2.25" THREAD VENTED	22	663-203P	1	BRACE, COOLER
11	F-1125	2	5/16-18 STOVER NUT	23	F-2063	2	NUT, 5/16-18, FLANGED NYLOC
12	H-2805	1	OIL TANK	24	H-2535	3	7/8" CLAMP

E-6415 WIRE HARNESS & RELATED PARTS (JOYSTICK)

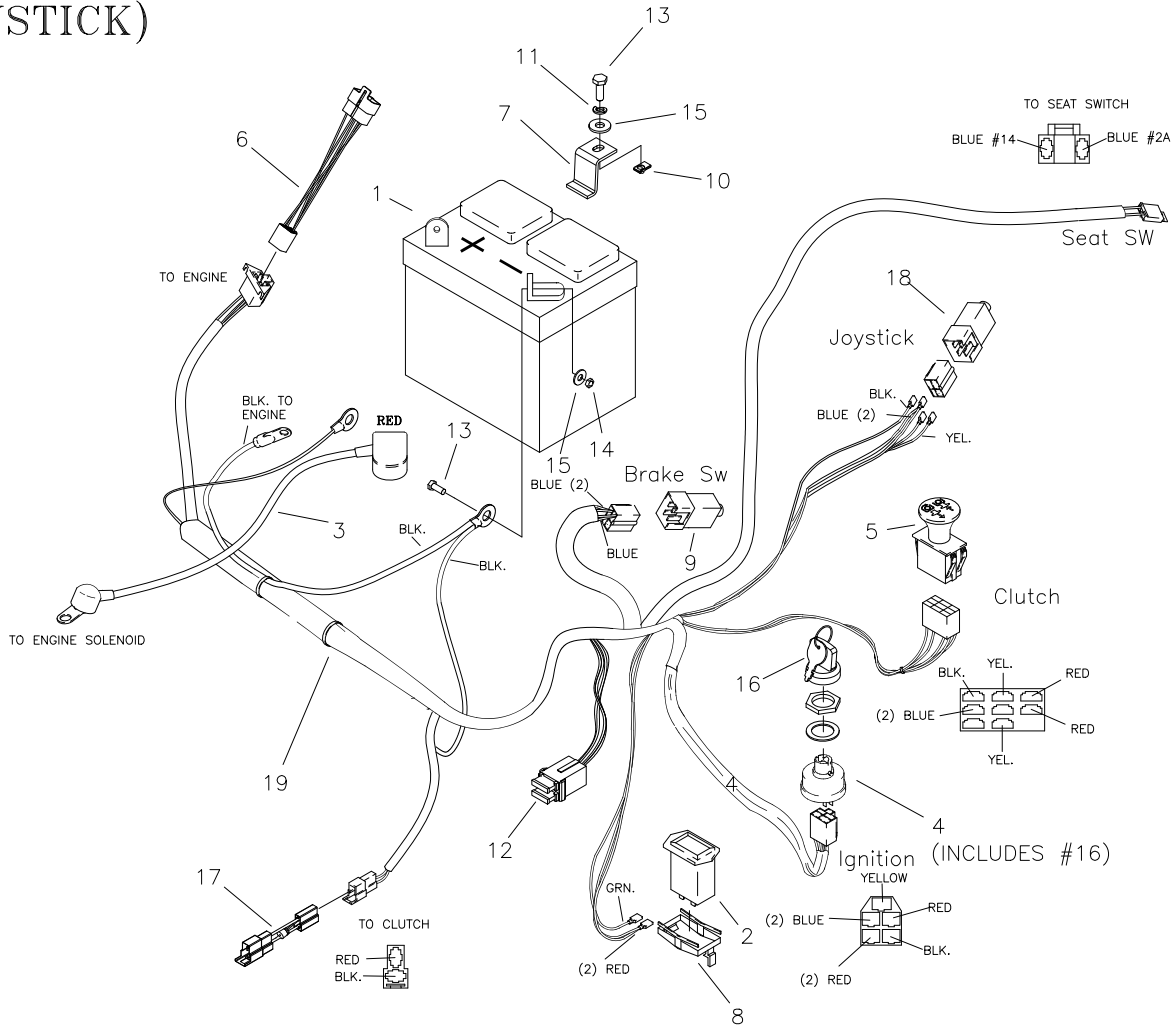

REF NO.	PART NO.	QTY.	DESCRIPTION
1	E-6271	1	BATTERY
2	E-5878	1	HOUR METER
3	E-6418	1	CABLE, BATTERY TO SOLENOID
4	E-5873	1	START SWITCH
5	E-6403	1	CLUTCH SWITCH
6	E-6417	1	WIRE HARNESS ADAPTER (KAWASAKI)
-	E-6547	1	WIRE HARNESS ADAPTER (KOHLER)
7	659-137P	1	BATTERY HOLD DOWN
8	E-6369	1	RETAINER CLIP
9	E-6297	2	BRAKE SWITCH
10	F-1858	1	1/4-20 U-NUT
11	F-1019-01	1	1/4" LOCK WASHER
12	E-6207	2	FUSE, #ATC-30
13	F-1538	3	1/4-20 X 3/4" GR. 5
14	F-1158	2	1/4-20 LOCK NUT
15	F-1009-01	5	1/4" FLAT WASHER
16	E-6445	1	KEY, SET
17	E-6461	1	CLUTCH SPIKE SUPPRESSOR (KOHLER)
18	E-6474	1	JOYSTICK SWITCH
19	E-6415	1	WIRE HARNESS
*	E-6374	1	SEAT SWITCH (NOT SHOWN)

E-6416 WIRE HARNESS & RELATED PARTS (TWINSTICK)

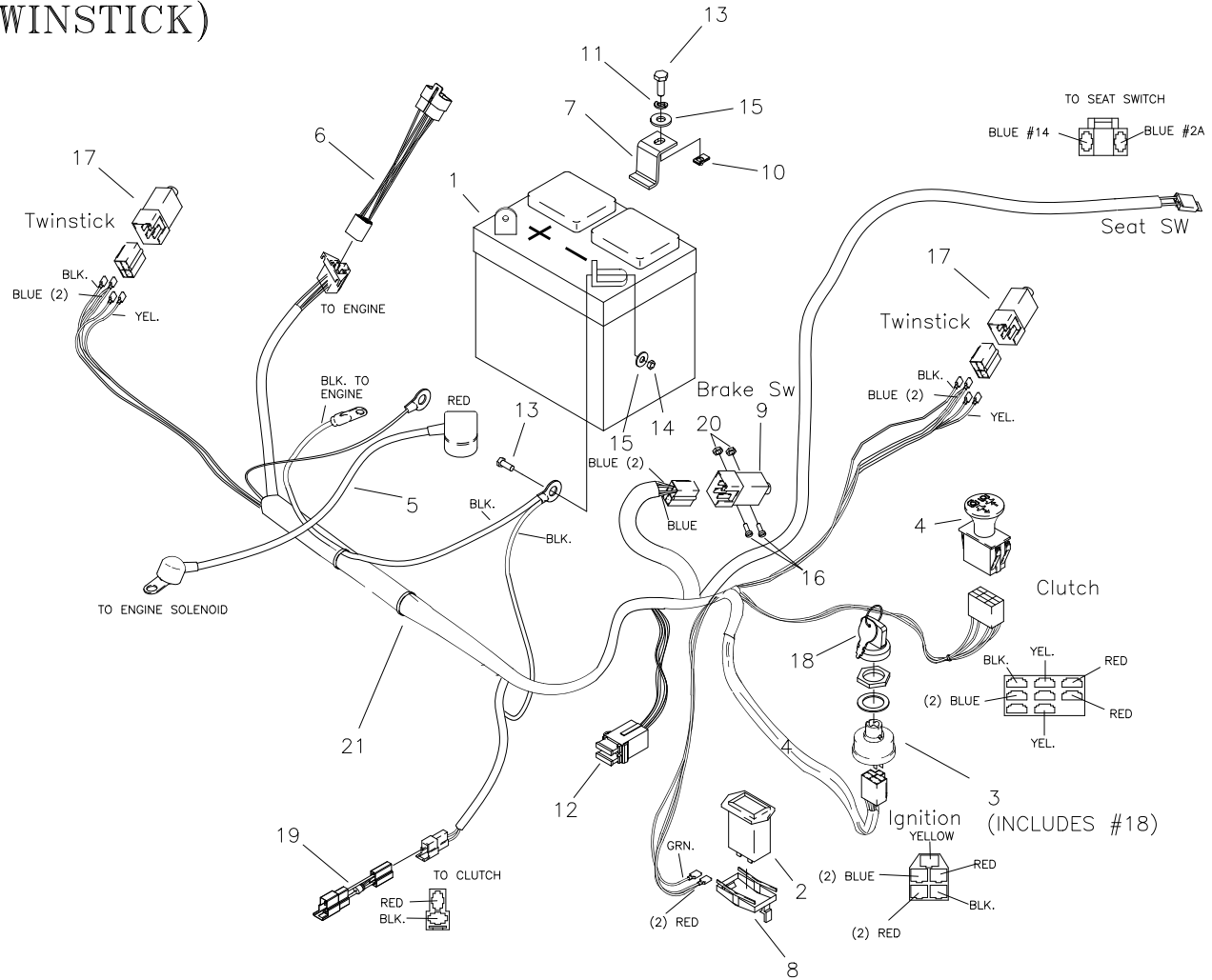

REF NO.	PART NO.	QTY.	DESCRIPTION
1	E-6271	1	BATTERY
2	E-5878	1	HOUR METER
3	E-5873	1	START SWITCH
4	E-6403	1	CLUTCH SWITCH
5	E-6418	1	CABLE, BATTERY TO SOLENOID
6	E-6417	1	WIRE HARNESS ADAPTER (KAWASAKI)
-	E-6547	1	WIRE HARNESS ADAPTER (KOHLER)
7	659-137P	1	BATTERY HOLD DOWN
8	E-6369	1	RETAINER CLIP
9	E-6297	1	BRAKE SWITCH
10	F-1858	1	1/4-20 U-NUT
11	F-1019-01	1	1/4" LOCK WASHER
12	E-6207	2	FUSE, #ATC-30
13	F-1538	3	1/4-20 X 3/4" GR. 5
14	F-1158	2	1/4-20 LOCK NUT
15	F-1009-01	3	1/4" FLAT WASHER
16	F-1022-26	2	SCREW, PHILLIPS, 10-32 X 5/8
17	E-6474	2	SWITCH, SNAP MOUNT
18	E-6445	1	KEY, SET
19	E-6461	1	CLUTCH SPIKE SUPPRESSOR (KOHLER)
20	F-1448	2	LOCKNUT, 10-32 NYLOC
21	E-6416	1	WIRE HARNESS
*	E-6374	1	SEAT SWITCH (NOT SHOWN)

E-6417 KAWASAKI ADAPTER HARNESS & RELATED PARTS

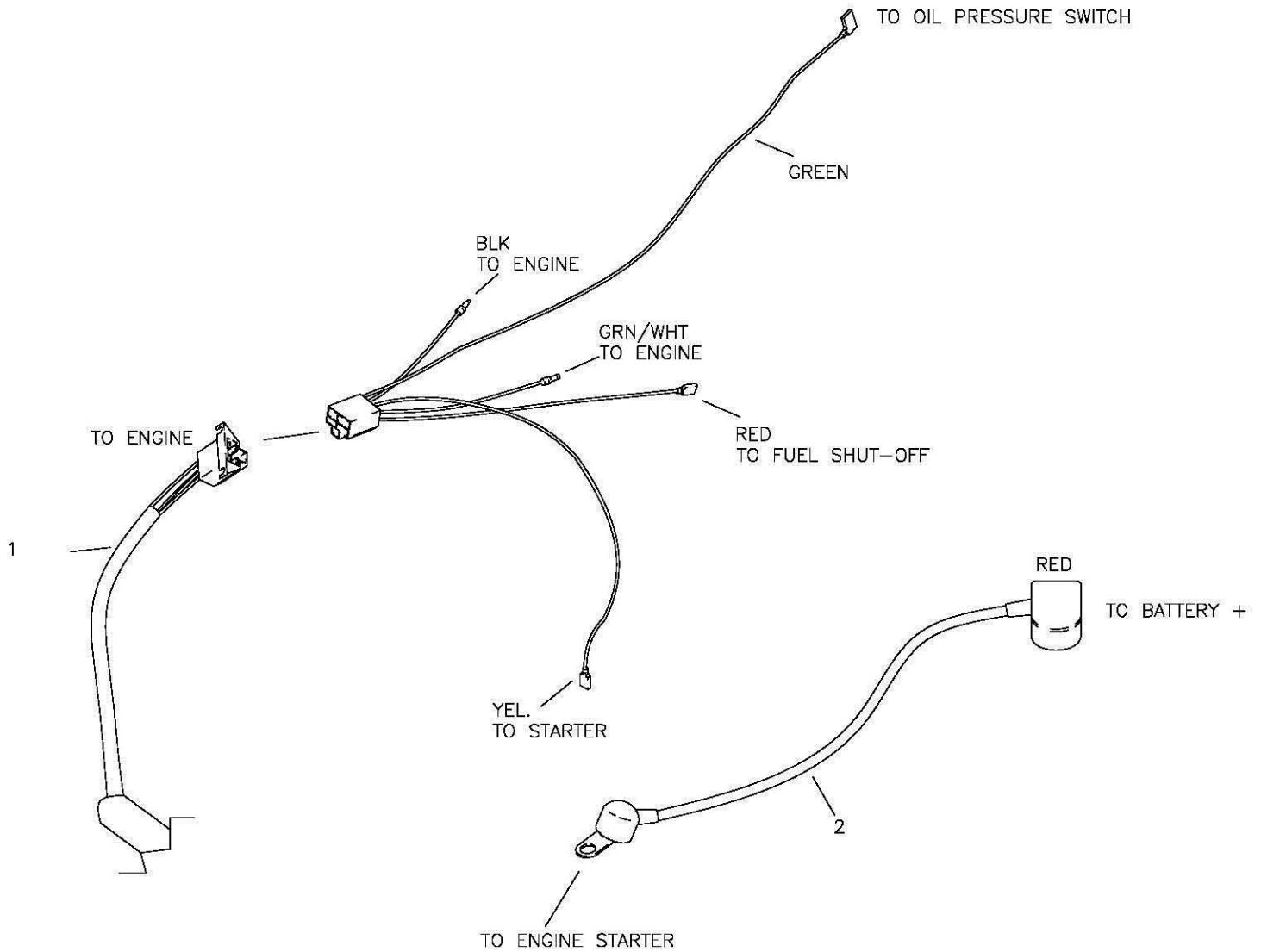

REF NO.	PART NO.	QTY.	DESCRIPTION
1	E-6415	1	WIRE HARNESS (JOYSTICK)
-	E-6416	1	WIRE HARNESS (TWINSTICK)
2	E-6418	1	CABLE, BATTERY TO SOLENOID

E-6547 KOHLER E.F.I. HARNESS ADAPTER & RELATED PARTS

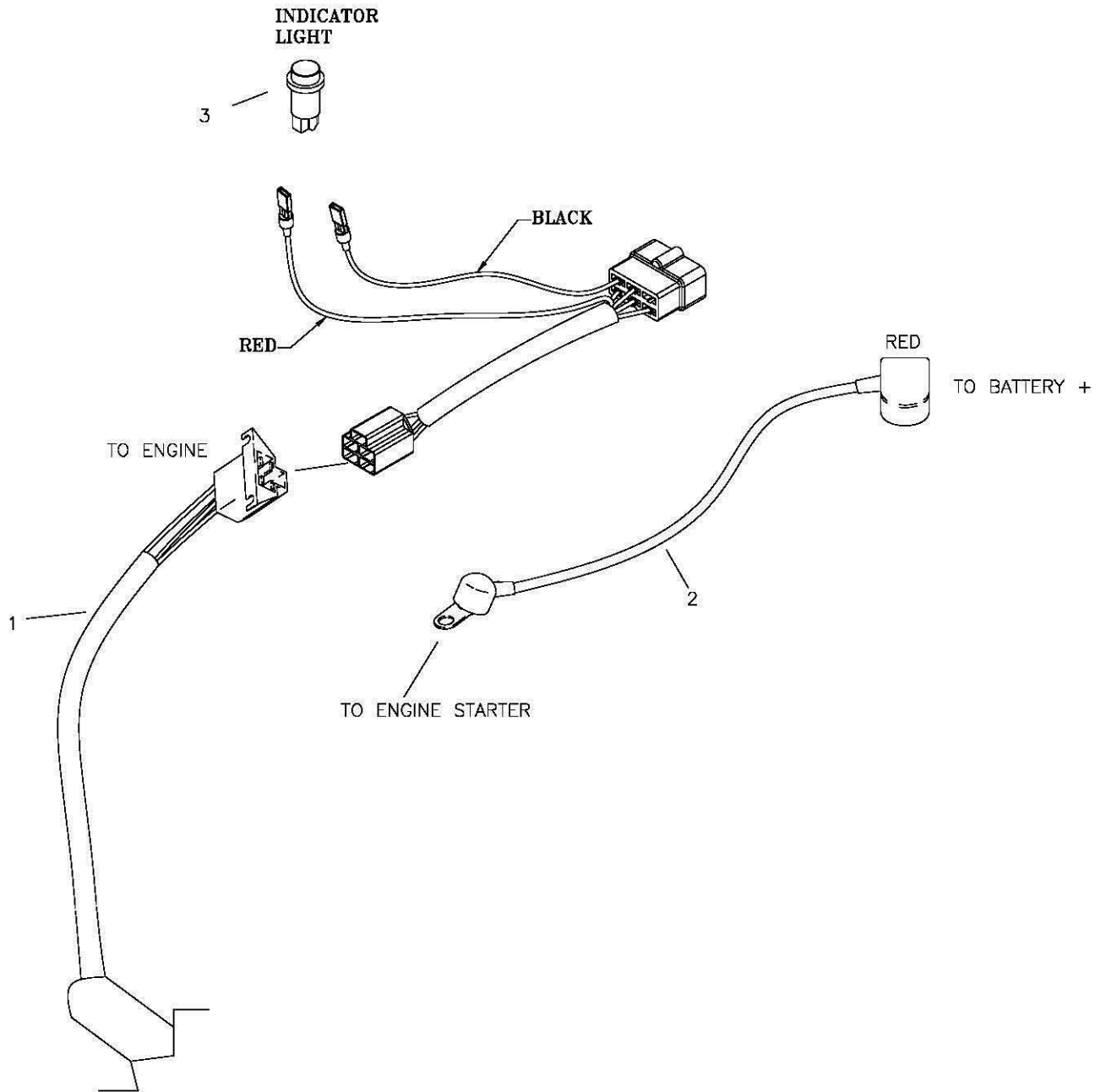

REF NO.	PART NO.	QTY.	DESCRIPTION
1	E-6415	1	WIRE HARNESS (JOYSTICK)
-	E-6416	1	WIRE HARNESS (TWINSTICK)
2	E-6418	1	CABLE, BATTERY TO SOLENOID
3	E-6314	1	INDICATOR LIGHT

Repair Parts Manual



CHARGER™

1040

Country Clipper Division
Shivers Manufacturing Inc.
613 W. English St.
Corydon, IA 50060-0467
Ph. 641-872-2544
Fax. 641-872-1593