

REPAIR PARTS MANUAL

for

COUNTRY
CLIPPER®

JAZZEE™ SR220

JAZZEE™ SR370
PRO

COUNTRY CLIPPER "JAZEE" AND "JAZEE PRO" ZERO TURN RADIUS MOWER

TABLE OF CONTENTS

PAGE.... CONTENTS

SECTION 1 – MOWER DECKS AND RELATED PARTS

- 1-1. . . . 42" DECK ASSEMBLY
- 1-1A . . 48" DECK ASSEMBLY
- 1-1B . . 52" DECK ASSEMBLY
- 1-1C . . 60" DECK ASSEMBLY
- 1-2 . . . DECK SPINDLE ASSEMBLY
- 1-3. . . . LIFT HANDLE ASSEMBLY & RELATED PARTS
- 1-4LIFT ASSEMBLY & RELATED PARTS
- 1-5. . . . TRANSMISSION IDLERS & RELATED PARTS

SECTION 2 –TRACTOR FRAME AND RELATED PARTS

- 2-6.CASTER WHEEL ASSEMBLY
- 2-7.FRAME SIDES & RELATED PARTS FOR JAZEE SR220
- 2-8.FRAME SIDES & RELATED PARTS FOR JAZEE PRO SR370
- 2-9.FENDER ASSEMBLY
- 2-10. . . .SEAT, FOOT DECK & RELATED PARTS
- 2-11. . . .FRONT STEP & RELATED PARTS FOR JAZEE PRO SR370

SECTION 3 –TRACTOR DRIVE AND RELATED PARTS

- 3-12. . . .FUEL TANK ASSEMBLY
- 3-13. . . .JOYSTICK STEERING CONTROL & RELATED PARTS
- 3-14. . . .JOYSTICK STEERING CONTROL & RELATED PARTS FOR JAZEE & JAZEE PRO
- 3-15. . . .TWINSTICK STEERING CONTROL AND RELATED PARTS
- 3-16. . . .PARKING BRAKE ASSEMBLY & RELATED PARTS FOR JAZEE SR220
- 3-17. . . .PARKING BRAKE ASSEMBLY & RELATED PARTS FOR JAZEE PRO SR370
- 3-18. . . .MOTOR AND TRANSMISSION ASSY & RELATED PARTS FOR JAZEE 20HP KOH SR220
- 3-19. . . .MOTOR AND TRANSMISSION ASSY & RELATED PARTS FOR JAZEE 24HP KOH SR220
- 3-20. . . .MOTOR AND TRANSMISSION ASSY & RELATED PARTS FOR JAZEE PRO 22HP KAW SR370
- 3-21. . . .MOTOR AND TRANSMISSION ASSY & RELATED PARTS FOR JAZEE PRO 27HP KOH SR370
- 3-22. . . .E-6405 WIRE HARNESS & RELATED PARTS 20 HP, 24HP, & 27HP KOHLER
- 3-23. . . .E-6415 WIRE HARNESS & RELATED PARTS 22HP KAWASAKI - JOYSTICK
- 3-24. . . .E-6416 WIRE HARNESS & RELATED PARTS 20HP, 24HP,27HP KOH & 22HP KAW - TWINSTICK
- 3-25. . . .E-6417 WIRE HARNESS ADAPTER & RELATED PARTS 22HP KAW
- 3-26. . . .E-6436 WIRE HARNESS ADAPTER & RELATED PARTS 20HP, 24HP, & 27HP KOH - TWINSTICK

42" DECK ASSEMBLY

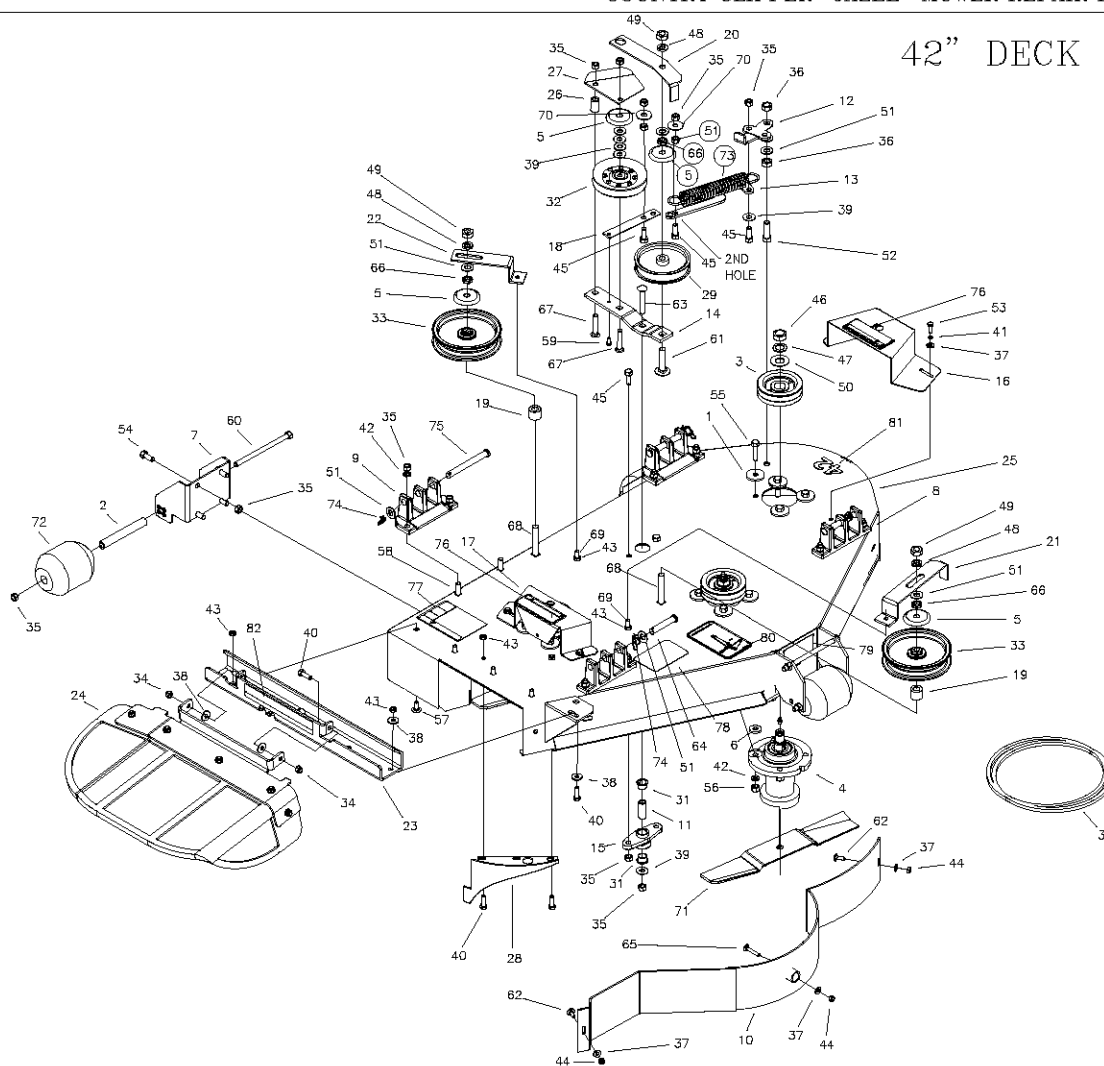

ITEM#	QTY	PART NUMBER	DESCRIPTION	ITEM#	QTY	PART NUMBER	DESCRIPTION
1	12	609-034P	Spindle Spacer Washer	43	9	F-1125	5/16-18 Stover Nut
2	3	609-183P	BUSHING	44	3	F-1158	1/4-20 Stover Nut
3	3	609-266P	PULLEY,DECK,3.75	45	5	F-1394	3/8-16 x 1" Capscrew
4	3	609F-019A	DECK SPINDLE ASSEMBLY	46	3	F-1461	3/4-16 JAM NUT
5	4	620-201P	WASHER, BEARING CAP	47	3	F-1463	3/4 LOCKWASHER
6	6	629-237P	WASHER, .406 ID X 1 OD X 10 GA	48	6	F-1464	1/2" LOCKWASHER
7	2	637-006P	SCALPER BRACKET	49	3	F-1489	1/2-13 Hex Jam Nut
8	2	643-016W	Hanger Weldment	50	3	F-1510	3/4 FLAT WASHER
9	2	651-009W	CASTING,HANGER,WIDE BASE	51	9	F-1521	1/2" WASHER, CUSTOM
10	1	651-022W	DUST BAFFLE	52	4	F-1526	1/2-13 x1-1/2" Capscrew
11	1	659-085P	Mounting Pin	53	4	F-1538	1/4-20 x 3/4" Capscrew
12	1	660-030P	Belt Tightner Handle	54	8	F-1558	3/8-16 x 7/8" Capscrew
13	1	660-031P	Belt Tightner Arm	55	12	F-1572	3/8-24 x 1.5" Capscrew
14	1	660-036P	Idler Arm	56	12	F-1573	3/8-24 LOCKNUT
15	1	660-039P	Double Idler Mount	57	4	F-1671	5/16-18 x 3/4" CARRIAGE BOLT
16	1	660-052A	PULLEY COVER-W/DECAL	58	8	F-1672	3/8-16 x 1-1/4" Carraige Bolt
17	1	660-053A	PULLEY COVER-W/DECAL	59	1	F-1733	1/4" x 1/2" DRIVE SCREW
18	1	660-081P	EXTENSION FOR SPRING	60	4	F-1741	3/8-16 x 6" Capscrew
19	2	660-083P	spacer	61	1	F-1822	1/2-13 X 2-1/4" CARRIAGE BOLT
20	1	660-107P	BELT KEEPER	62	2	F-1823	Carriage Bolt, 1/4 X 3/4"
21	1	660-112P	BELT KEEPER	63	1	F-1865	3/8-16 x 2-1/2" Carraige Bolt
22	1	660-114P	BELT KEEPER, SINGLE END	64	2	F-1889	1/2 x 2-5/8" Clevis Pin
23	1	660-120P	OUTLET STIFFENER, SMALL	65	1	F-1935	CARRIAGE BOLT, 1/4 X 1-1/2"
24	1	660-122A	RUBBER CHUTE ASS'Y, SM.	66	3	F-1966	1/2-13 THIN NYLOC NUT
25	1	660M-003W	42" DECK WELDMENT (ASS'Y 660V-002A)	67	2	F-1976	3/8-16 x 2" Carraige Bolt
26	1	668-021P	SPACER, BELT GUARD	68	2	F-2047	1/2-13 X 3" CARRIAGE BOLT
27	1	668-029P	BELT GUARD	69	2	F-2066	5/16-18 x 1" CARRIAGE BOLT,
28	1	686-006W	SPLITTER BAFFLE	70	2	F-2083	WASHER, 3/8 FENDER
29	1	D-3338	Pulley flat idler 1/2" Bore 4"	71	3	H-1715	BLADE, 15" HIGH LIFT
30	1	D-3727-W	BELT, B-144	72	3	H-1948	Roller, 3-3/4 DIA. x 4-13/16L
31	2	D-3730	Flanged Bushing 5/8" Bore	73	1	H-2092	1-1/4" x 5" Extention Spring
32	1	D-3758	PULLEY V-IDLER 4.48 O.D. 3/8 HOLE	74	4	H-2239	1/2" Rue Ring
33	2	D-3774	IDLER PULLEY 5"	75	2	H-2240	1/2" x 4-1/2" Clevis Pin
34	2	F-1005-02	5/16-18 Nyloc Nut	76	2	P-10935	Decal, WARNING
35	30	F-1005-03	3/8-16 Stover Nut	77	1	P-10941	DECAL "DANGER ROTATING BLADES"
36	2	F-1005-05	1/2-13 Stover Nut	78	1	P-10947	DECAL " GREASE DECK SPINDLES"
37	7	F-1009-01	1/4" Flat Washer	79	1	P-11413	DECAL, HOIST POINT
38	4	F-1009-02	5/16" Flat Washer	80	1	P-11932	DECAL, JAZEE DECK BELT ROUTING
39	6	F-1009-03	3/8" Flat Washer	81	1	P-11949	DECAL, DECK SIZE, 42
40	5	F-1015-15	5/16-18 x 1" Capscrew	82	1	P-12496	DECAL, MISSING CHUTE
41	4	F-1019-01	1/4" LockWasher	83	3	F-1507	CUPPED WASHER, 1/2"
42	20	F-1019-03	3/8" LOCKWASHER				

48" DECK ASSEMBLY

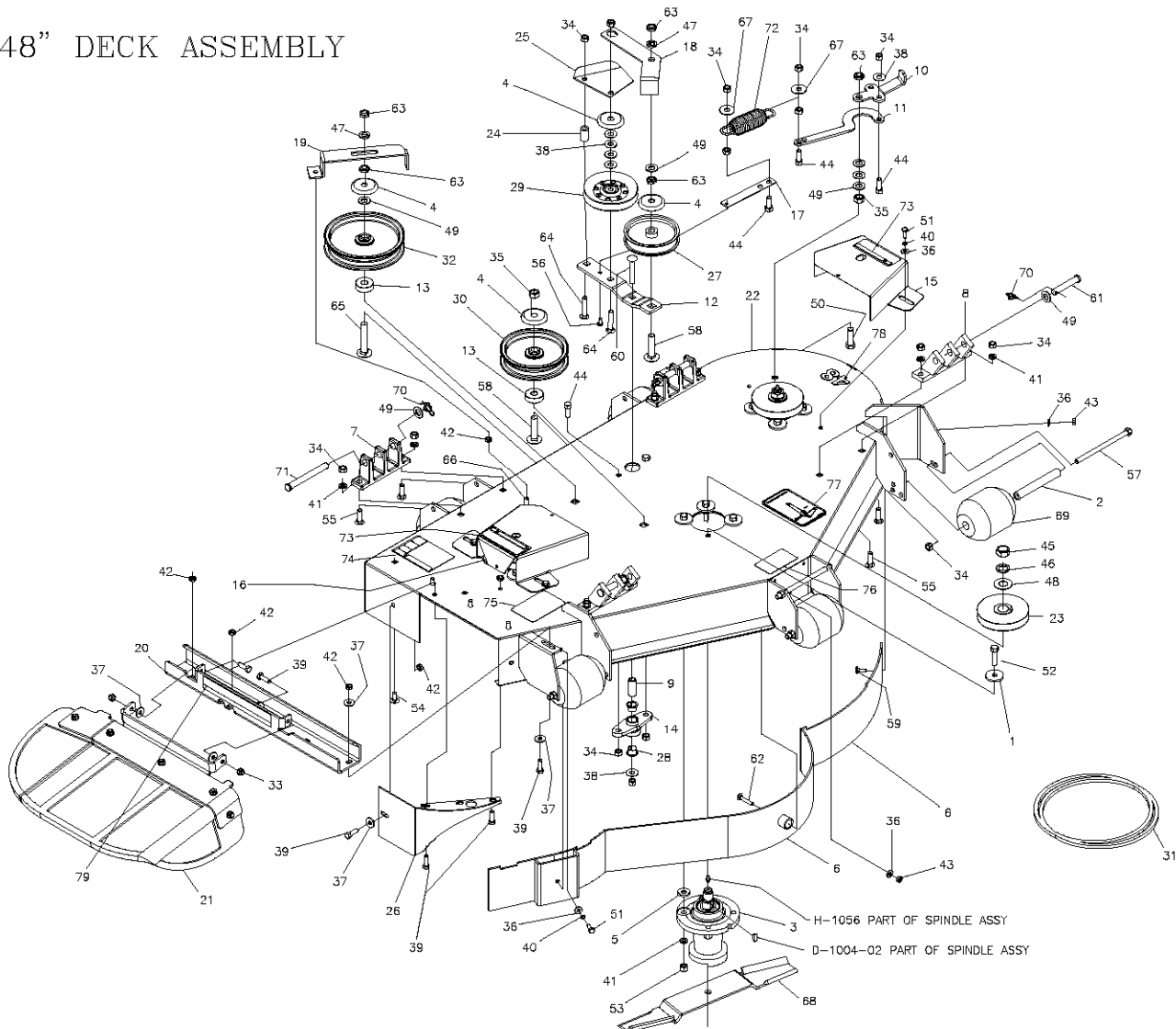

ITEM#	QTY	PART NUMBER	DESCRIPTION	ITEM#	QTY	PART NUMBER	DESCRIPTION
1	12	609-034P	Spindle Spacer Washer	41	20	F-1019-03	3/8" LOCKWASHER
2	5	609-183P	BUSHING	42	9	F-1125	5/16-18 Stover Nut
3	3	609F-019A	DECK SPINDLE ASSEMBLY	43	2	F-1158	1/4-20 Stover Nut
4	4	620-201P	WASHER, BEARING CAP	44	5	F-1394	3/8-16 x 1" Capscrew
5	6	629-237P	WASHER, .406 ID X 1 OD X 10 GA	45	3	F-1461	3/4-16 JAM NUT
6	1	629-241W	Baffle Wtd. 48"	46	3	F-1463	3/4 LOCKWASHER
7	2	643-016W	Hanger Weldment	47	5	F-1464	1/2" LOCKWASHER
8	2	651-009W	DECK MOUNT WELDMENT	48	3	F-1510	3/4 FLAT WASHER
9	1	659-085P	Mounting Pin	49	9	F-1521	1/2" WASHER, CUSTOM
10	1	660-030P	Belt Tightner Handle	50	4	F-1526	1/2-13 x 1-1/2" Capscrew
11	1	660-031P	Belt Tightner Arm	51	5	F-1538	1/4-20 x 3/4" Capscrew
12	1	660-036P	Idler Arm	52	12	F-1572	3/8-24 x 1.5" Capscrew
13	2	660-037P	SPACER 1/2"	53	12	F-1573	3/8-24 LOCKNUT
14	1	660-039P	Double Idler Mount	54	4	F-1671	5/16-18 x 3/4" CARRIAGE BOLT
15	1	660-054A	PULLEY COVER, LH-W/DECAL	55	8	F-1672	3/8-16 x 1-1/4" Carraige Bolt
16	1	660-055A	PULLEY COVER, RH-W/DECAL	56	1	F-1733	1/4" x 1/2" DRIVE SCREW
17	1	660-081P	EXTENSION FOR SPRING	57	6	F-1741	3/8-16 x 6" Capscrew
18	1	660-110P	BELT KEEPER, B BELT	58	2	F-1822	1/2-13 X 2-1/4" CARRIAGE BOLT
19	1	660-112P	BELT KEEPER	59	1	F-1823	Carriage Bolt, 1/4 X 3/4"
20	1	660-120P	OUTLET STIFFENER, SMALL	60	1	F-1865	3/8-16 x 2-1/2" Carraige Bolt
21	1	660-122A	RUBBER CHUTE ASS'Y, SM.	61	2	F-1898	1/2 x 2-3/4" Clevis Pin
22	1	660N-003W	WLDT, DECK 48" (ASS'Y 660S-002A)	62	1	F-1935	CARRIAGE BOLT, 1/4 X 1-1/2"
23	3	668-014P	48" PULLEY	63	5	F-1966	1/2-13 THIN NYLOC NUT
24	1	668-021P	SPACER, BELT GUARD	64	2	F-1976	3/8-16 x 2" Carraige Bolt
25	1	668-029P	BELT GUARD	65	1	F-2047	1/2-13 X 3" CARRIAGE BOLT
26	1	686-080W	SPLITTER BAFFLE	66	1	F-2066	5/16-18 x 1" CARRIAGE BOLT,
27	1	D-3338	Pulley flat idler 1/2" Bore 4"	67	2	F-2083	WASHER, 3/8 FENDER
28	2	D-3730	Flanged Bushing 5/8" Bore	68	3	H-1714	BLADE, 17" HIGH LIFT
29	1	D-3758	PULLEY V-IDLER 4.48 O.D. 3/8 HOLE	69	5	H-1948	Roller, 3-3/4 DIA. x 4-13/16L
30	1	D-3774	IDLER PULLEY 5"	70	4	H-2239	1/2" Rue Ring
31	1	D-3775-W	BELT, B-158	71	2	H-2240	1/2" x 4-1/2" Clevis Pin
32	1	D-3815	IDLER PULLEY 6"	72	1	H-2619	SPRING, 5 X 1-1/2, TAPERED ENDS
33	2	F-1005-02	5/16-18 Nyloc Nut	73	2	P-10935	Decal, WARNING
34	24	F-1005-03	3/8-16 Stover Nut	74	1	P-10941	DECAL "DANGER ROTATING BLADES"
35	2	F-1005-05	1/2-13 Stover Nut	75	1	P-10947	DECAL " GREASE DECK SPINDLES"
36	7	F-1009-01	1/4" Flat Washer	76	1	P-11413	DECAL, HOIST POINT
37	5	F-1009-02	5/16" Flat Washer	77	1	P-11932	DECAL, JAZEE DECK BELT ROUTING
38	6	F-1009-03	3/8" Flat Washer	78	1	P-11950	DECAL, DECK SIZE, 48
39	6	F-1015-15	5/16-18 x 1" Capscrew	79	1	P-12496	DECAL, MISSING CHUTE
40	5	F-1019-01	1/4" LockWasher	80	3	F-1507	CUPPED WASHER, 1/2"

52" DECK ASSEMBLY

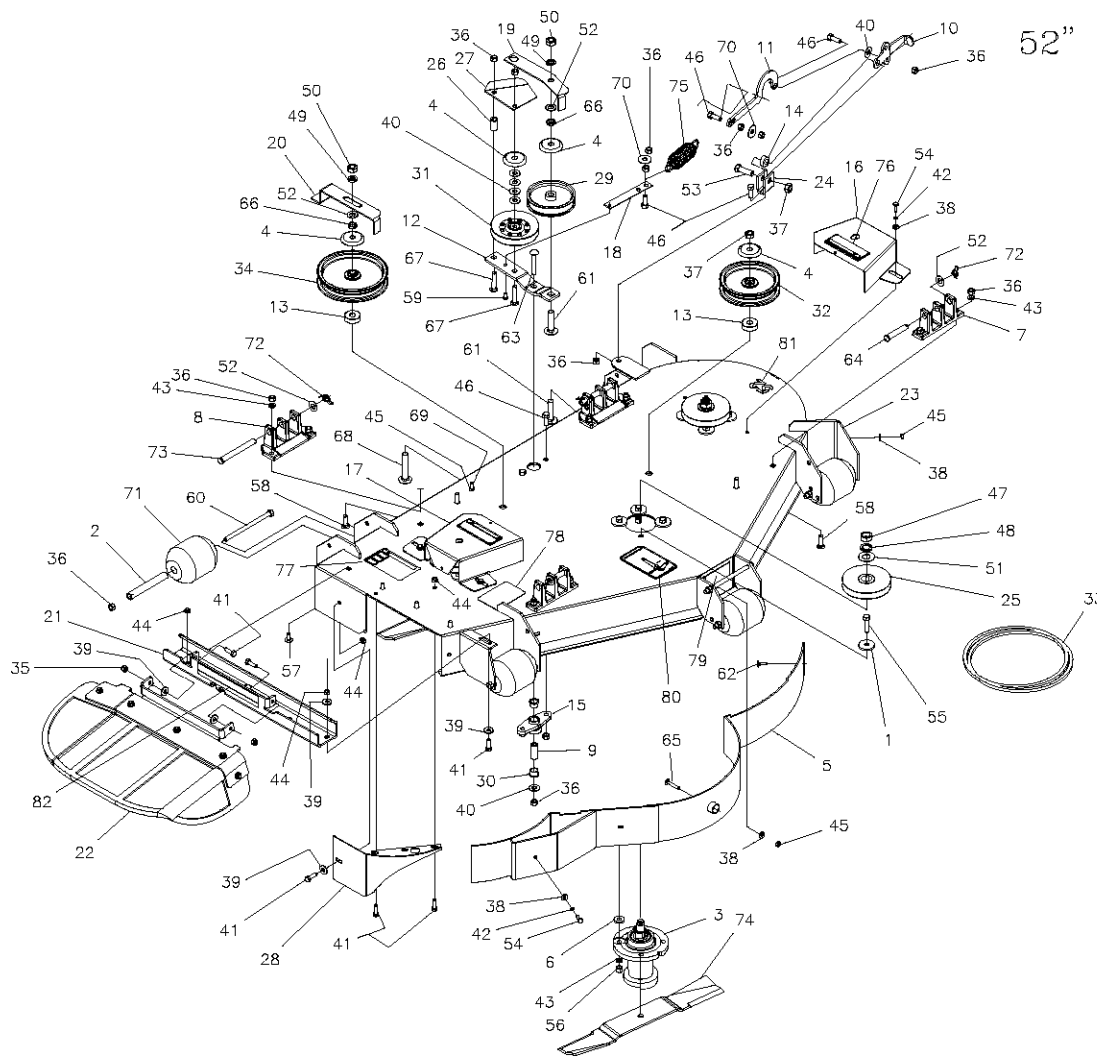

ITEM#	QTY	PART NUMBER	DESCRIPTION	ITEM#	QTY	PART NUMBER	DESCRIPTION
1	12	609-034P	Spindle Spacer Washer	43	20	F-1019-03	3/8" LOCKWASHER
2	5	609-183P	BUSHING	44	8	F-1125	5/16-18 Stover Nut
3	3	609F-019A	DECK SPINDLE ASSEMBLY	45	3	F-1158	1/4-20 Stover Nut
4	4	620-201P	WASHER, BEARING CAP	46	6	F-1394	3/8-16 x 1" Capscrew
5	1	629-229W	DUST BAFFLE, 52"	47	3	F-1461	3/4-16 JAM NUT
6	6	629-237P	WASHER, .406 ID X 1 OD X 10 GA	48	3	F-1463	3/4 LOCKWASHER
7	2	643-016W	Hanger Weldment	49	5	F-1464	1/2" LOCKWASHER
8	2	651-009W	CASTING,HANGER,WIDE BASE	50	2	F-1489	1/2-13 Hex Jam Nut
9	1	659-085P	Mounting Pin	51	3	F-1510	3/4 FLAT WASHER
10	1	660-030P	Belt Tightner Handle	52	6	F-1521	1/2" WASHER, CUSTOM
11	1	660-031P	Belt Tightner Arm	53	4	F-1526	1/2-13 x1-1/2" Capscrew
12	1	660-036P	Idler Arm	54	5	F-1538	1/4-20 x 3/4" Capscrew
13	2	660-037P	SPACER 1/2"	55	12	F-1572	3/8-24 x 1.5" Capscrew
14	1	680-038P	3/8" Spacer	56	12	F-1573	3/8-24 LOCKNUT
15	1	660-039P	Double Idler Mount	57	4	F-1671	5/16-18 x 3/4" CARRIAGE BOLT
16	1	660-054A	PULLEY COVER, LH-W/DECAL	58	8	F-1672	3/8-16 x 1-1/4" Carraige Bolt
17	1	660-055A	PULLEY COVER, RH-W/DECAL	59	1	F-1733	1/4" x 1/2" DRIVE SCREW
18	1	660-081P	EXTENSION FOR SPRING	60	6	F-1741	3/8-16 x 6" Capscrew
19	1	660-107P	BELT KEEPER	61	2	F-1822	1/2-13 X 2-1/4" CARRIAGE BOLT
20	1	660-112P	BELT KEEPER	62	1	F-1823	Carriage Bolt, 1/4 X 3/4"
21	1	660-120P	OUTLET STIFFENER, SMALL	63	1	F-1865	3/8-16 x 2-1/2" Carriage Bolt
22	1	660-122A	RUBBER CHUTE ASS'Y, SM.	64	2	F-1889	1/2 x 2-5/8" Clevis Pin
23	1	660P-003W	52" DECK WELDMENT (ASS'Y 660T-002A)	65	1	F-1935	CARRIAGE BOLT, 1/4 X 1-1/2"
24	1	661-015P	SHACKLE	66	2	F-1966	1/2-13 THIN NYLOC NUT
25	3	668-013P	PULLEY, 52"	67	2	F-1976	3/8-16 x 2" Carraige Bolt
26	1	668-021P	SPACER, BELT GUARD	68	1	F-2047	1/2-13 X 3" CARRIAGE BOLT
27	1	668-029P	BELT GUARD	69	1	F-2066	5/16-18 x 1" CARRIAGE BOLT,
28	1	686-080W	SPLITTER BAFFLE	70	2	F-2083	WASHER, 3/8 FENDER
29	1	D-3338	Pulley flat idler 1/2" Bore 4"	71	5	H-1948	Roller, 3-3/4 DIA. x 4-13/16L
30	2	D-3730	Flanged Bushing 5/8" Bore	72	4	H-2239	1/2" Rue Ring
31	1	D-3758	PULLEY V-IDLER 4.48 O.D. 3/8 HOLE	73	2	H-2240	1/2" x 4-1/2" Clevis Pin
32	1	D-3774	IDLER PULLEY 5"	74	3	H-2246	18-3/8 High lift blade
33	1	D-3776-W	BELT, B-180	75	1	H-2619	SPRING,5 X 1-1/2,TAPERED ENDS
34	1	D-3815	IDLER PULLEY 6"	76	2	P-10935	Decal, WARNING
35	2	F-1005-02	5/16-18 Nyloc Nut	77	1	P-10941	DECAL "DANGER ROTATING BLADES"
36	25	F-1005-03	3/8-16 Stover Nut	78	1	P-10947	DECAL " GREASE DECK SPINDLES"
37	2	F-1005-05	1/2-13 Stover Nut	79	1	P-11413	DECAL, HOIST POINT
38	7	F-1009-01	1/4" Flat Washer	80	1	P-11932	DECAL, JAZEE DECK BELT ROUTING
39	5	F-1009-02	5/16" Flat Washer	81	1	P-11951	DECAL, DECK SIZE, 52
40	6	F-1009-03	3/8" Flat Washer	82	1	P-12496	DECAL, MISSING CHUTE
41	6	F-1015-15	5/16-18 x 1" Capscrew	83	3	F-1507	CUPPED WASHER, 1/2"
42	5	F-1019-01	1/4" LockWasher				

60" DECK ASSEMBLY

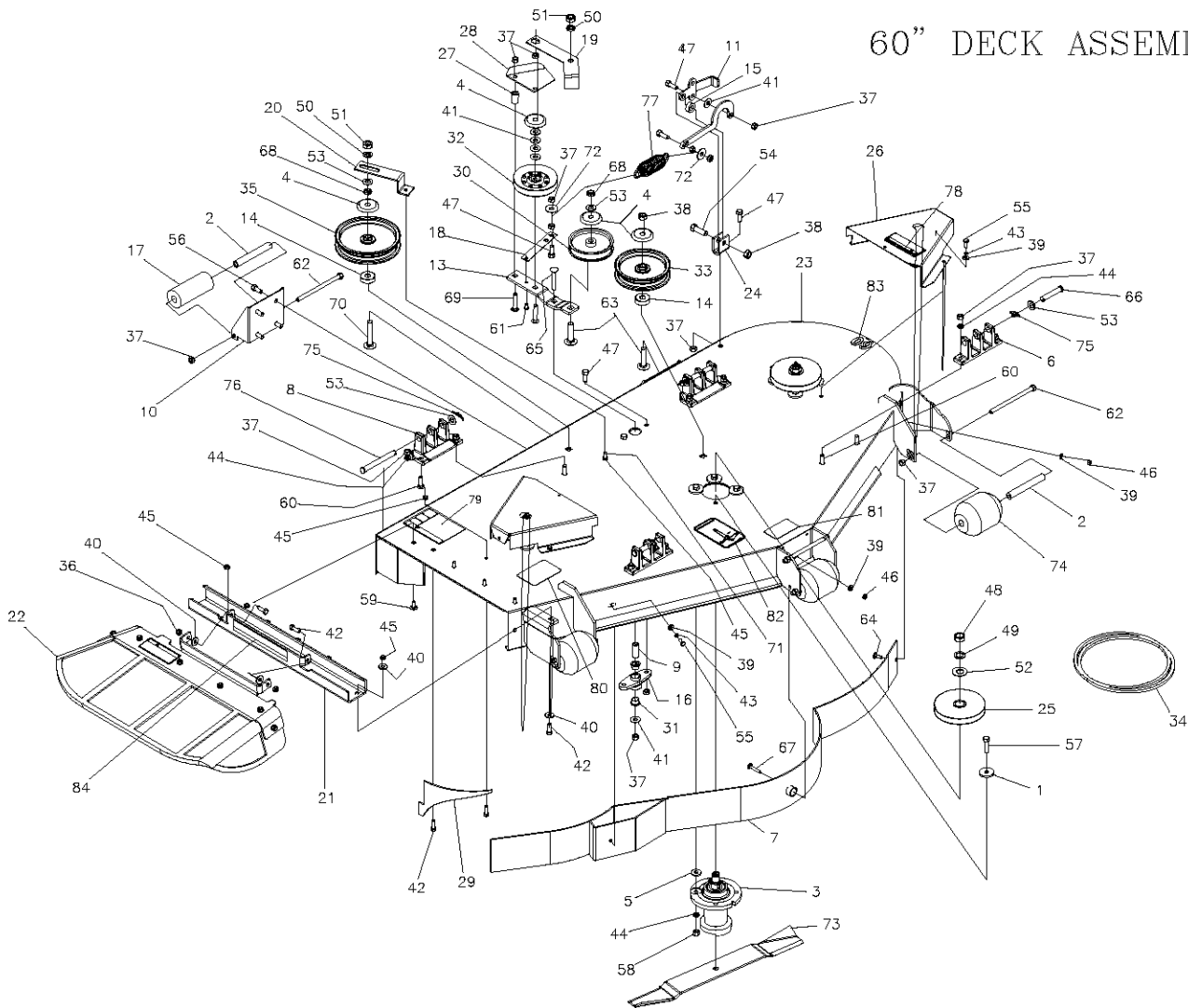

ITEM#	QTY	PART NUMBER	DESCRIPTION	ITEM#	QTY	PART NUMBER	DESCRIPTION
1	12	609-034P	Spindle Spacer Washer	44	20	F-1019-03	3/8" LOCKWASHER
2	5	609-183P	BUSHING	45	8	F-1125	5/16-18 Stover Nut
3	3	609F-019A	DECK SPINDLE ASSEMBLY	46	2	F-1158	1/4-20 Stover Nut
4	4	620-201P	WASHER, BEARING CAP	47	6	F-1394	3/8-16 x 1" Capscrew
5	6	629-237P	WASHER, 406 ID X 1 OD X 10 GA	48	3	F-1461	3/4-16 JAM NUT
6	2	643-016W	Hanger Weldment	49	3	F-1463	3/4 LOCKWASHER
7	1	643-047W	DUST BAFFLE	50	5	F-1464	1/2" LOCKWASHER
8	2	651-009W	CASTING,HANGER,WIDE BASE	51	2	F-1489	1/2-13 Hex Jam Nut
9	1	659-085P	Mounting Pin	52	3	F-1510	3/4 FLAT WASHER
10	2	659-139P	SCALPER BRACKET	53	6	F-1521	1/2" WASHER, CUSTOM
11	1	660-030P	Belt Tightner Handle	54	4	F-1526	1/2-13 x1-1/2" Capscrew
12	1	660-031P	Belt Tightner Arm	55	5	F-1538	1/4-20 x 3/4" Capscrew
13	1	660-036P	Idler Arm	56	8	F-1558	3/8-16 x 7/8" Capscrew
14	2	660-037P	SPACER 1/2"	57	12	F-1572	3/8-24 x 1.5" Capscrew
15	1	660-038P	3/8" Spacer	58	12	F-1573	3/8-24 LOCKNUT
16	1	660-039P	Double Idler Mount	59	4	F-1671	5/16-18 x 3/4" CARRIAGE BOLT
17	2	660-076P	ROLLER	60	8	F-1672	3/8-16 x 1-1/4" Carriage Bolt
18	1	660-081P	EXTENSION FOR SPRING	61	1	F-1733	1/4" x 1/2" DRIVE SCREW
19	1	660-110P	BELT KEEPER, B BELT	62	6	F-1741	3/8-16 x 6" Capscrew
20	1	660-114P	BELT KEEPER, SINGLE END	63	2	F-1822	1/2-13 x 2-1/4" CARRIAGE BOLT
21	1	660-123P	OUTLET STIFFENER, LARGE	64	1	F-1823	Carriage Bolt, 1/4 X 3/4"
22	1	660-125A	RUBBER CHUTE ASSEMBLY, LARGE	65	1	F-1865	3/8-16 x 2-1/2" Carriage Bolt
23	1	660R-003W	60" DECK WELDMENT (660U-002A)	66	2	F-1889	1/2 x 2-5/8" Clevis Pin
24	1	661-015P	SHACKLE	67	1	F-1935	CARRIAGE BOLT, 1/4 X 1-1/2"
25	3	668-012P	PULLEY,60"	68	2	F-1966	1/2-13 THIN NYLOC NUT
26	2	668-024A	PULLEY COVER-W/DECAL	69	2	F-1976	3/8-16 x 2" Carriage Bolt
27	1	668-021P	SPACER, BELT GUARD	70	1	F-2047	1/2-13 X 3" CARRIAGE BOLT
28	1	668-029P	BELT GUARD	71	1	F-2066	5/16-18 x 1" CARRIAGE BOLT,
29	1	668-006W	SPLITTER BAFFLE	72	2	F-2083	WASHER, 3/8 FENDER
30	1	D-3338	Pulley flat idler 1/2" Bore 4"	73	3	H-1708	60" HIGH LIFT BLADE
31	2	D-3730	Flanged Bushing 5/8" Bore	74	3	H-1948	Roller, 3-3/4 DIA. x 4-13/16L
32	1	D-3758	PULLEY V-IDLER 4.48 O.D. 3/8 HOLE	75	4	H-2239	1/2" Rue Ring
33	1	D-3774	IDLER PULLEY 5"	76	2	H-2240	1/2" x 4-1/2" Clevis Pin
34	1	D-3776-W	BELT, B-180	77	1	H-2619	SPRING,5 X 1-1/2,TAPERED ENDS
35	1	D-3815	IDLER PULLEY 6"	78	2	P-10935	Decal, WARNING
36	2	F-1005-02	5/16-18 Nyloc Nut	79	1	P-10941	DECAL "DANGER ROTATING BLADES"
37	33	F-1005-03	3/8-16 Stover Nut	80	1	P-10947	DECAL " GREASE DECK SPINDLES"
38	2	F-1005-05	1/2-13 Stover Nut	81	1	P-11413	DECAL, HOIST POINT
39	7	F-1009-01	1/4" Flat Washer	82	1	P-11932	DECAL, JAZEE DECK BELT ROUTING
40	4	F-1009-02	5/16" Flat Washer	83	1	P-11952	DECAL, DECK SIZE, 60
41	6	F-1009-03	3/8" Flat Washer	84	1	P-12496	DECAL, MISSING CHUTE
42	5	F-1015-15	5/16-18 x 1" Capscrew	85	3	F-1507	CUPPED WASHER, 1/2"
43	5	F-1019-01	1/4" LockWasher				

DECK SPINDEL ASSEMBLY

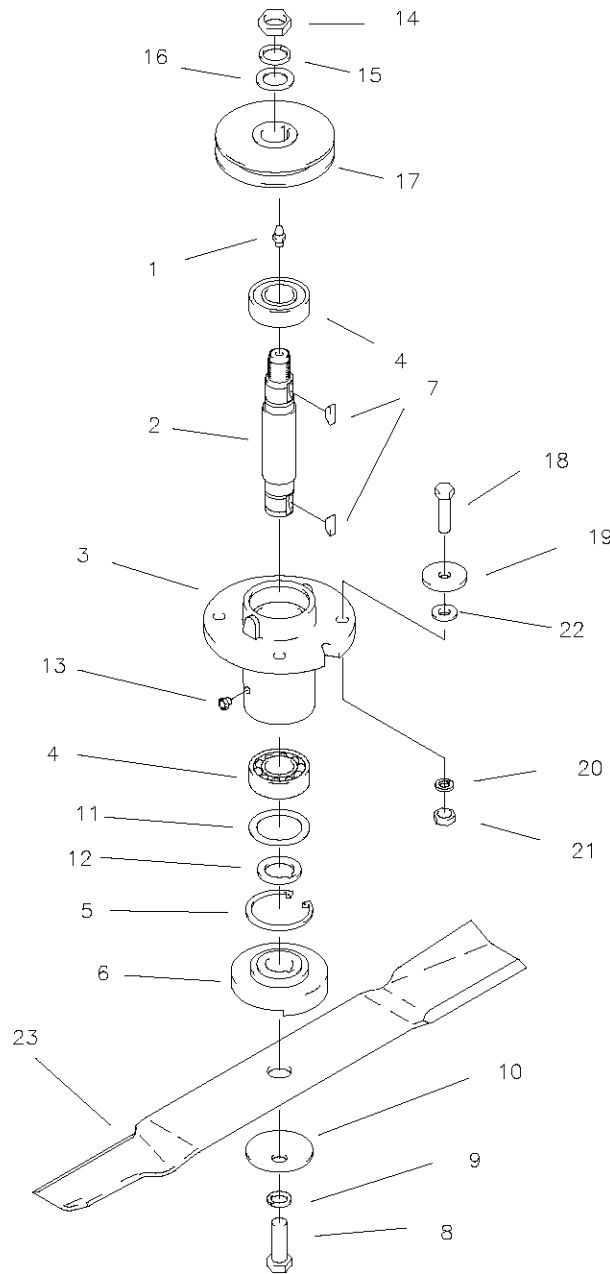

ITEM #	PART #	QTY	DESCRIPTION	ITEM #	PART #	QTY	DESCRIPTION
-	606F-019A	-	SPINDLE ASSEMBLY	18	F-1572	4	3/8-24 X 1-1/2" HHCS GR. 5
1	H-1056	1	GREASE FITTING	19	609-034P	4	SPINDLE SPACER REINFORCEMENT
2	609-162P	1	SPINDLE SHAFT	20	F-1019-03	4	3/8" LOCK WASHER
3	609-223P	1	SPINDLE HOUSING	21	F-1573	4	3/8-24 LOCKNUT, M-F
4	D-3058	2	BEARING, #6205-2RS	22	629-237P	4	WASHER .406 x 1 O.D. x 10GA.
5	H-1893	1	SNAP RING INT. 52MM	23	H-1714	1	BLADE, HIGH L, 17" CUT 48"
6	609-152P	1	BLADE SPACER	-	H-1715	-	BLADE, HIGH L, 15" CUT 42"
7	D-1004-02	2	KEY, WOODRUF, 1/4 X 3/4	-	H-2246	-	BLADE, HIGH L, 18 3/8" CUT 52"
8	F-1526	1	1/2-13 X 1-1/2" HHCS GR. 5	-	H-1708	-	BLADE, HIGH L, 21" CUT 60"
9	F-1464	1	1/2" LOCK WASHER	-			OPTIONAL BLADES
10	F-1507	1	WASHER, 1/2" CUPPED	-	H-1666	-	BLADE, LOW L, 17" CUT 48"
11	609-151P	1	WASHER, SEAL	-	H-1665	-	BLADE, LOW L, 15" CUT 42"
12	609-073P	1	ARBOR SPACER	-	H-2387	-	BLADE, LOW L, 18 3/8" CUT, 52"
13	H-2066	1	GREASE VENT 5 LBS.	-	H-1667	-	BLADE, LOW L, 21" CUT, 60"
14	F-1461	1	3/4-16 NUT, HEX JAM	-	H-2013	-	BLADE, GATOR, 15" CUT 42"
15	F-1463	1	3/4" LOCK WASHER	-	H-2202	-	BLADE, GATOR, 17" CUT 48"
16	F-1510	1	3/4" WASHER, FLAT STD.	-	H-2251	-	BLADE, GATOR, 18 3/8" CUT 52"
17	609-266P	1	SPINDLE PULLEY, 42"	-	H-2122	-	BLADE, GATOR, 21" CUT 60"
-	668-014P	1	SPINDLE PULLEY, 48"				
-	668-013P	1	SPINDLE PULLEY, 52"				
-	668-012P	1	SPINDLE PULLEY, 60"				

LIFT HANDLE ASSEMBLY & RELATED PARTS

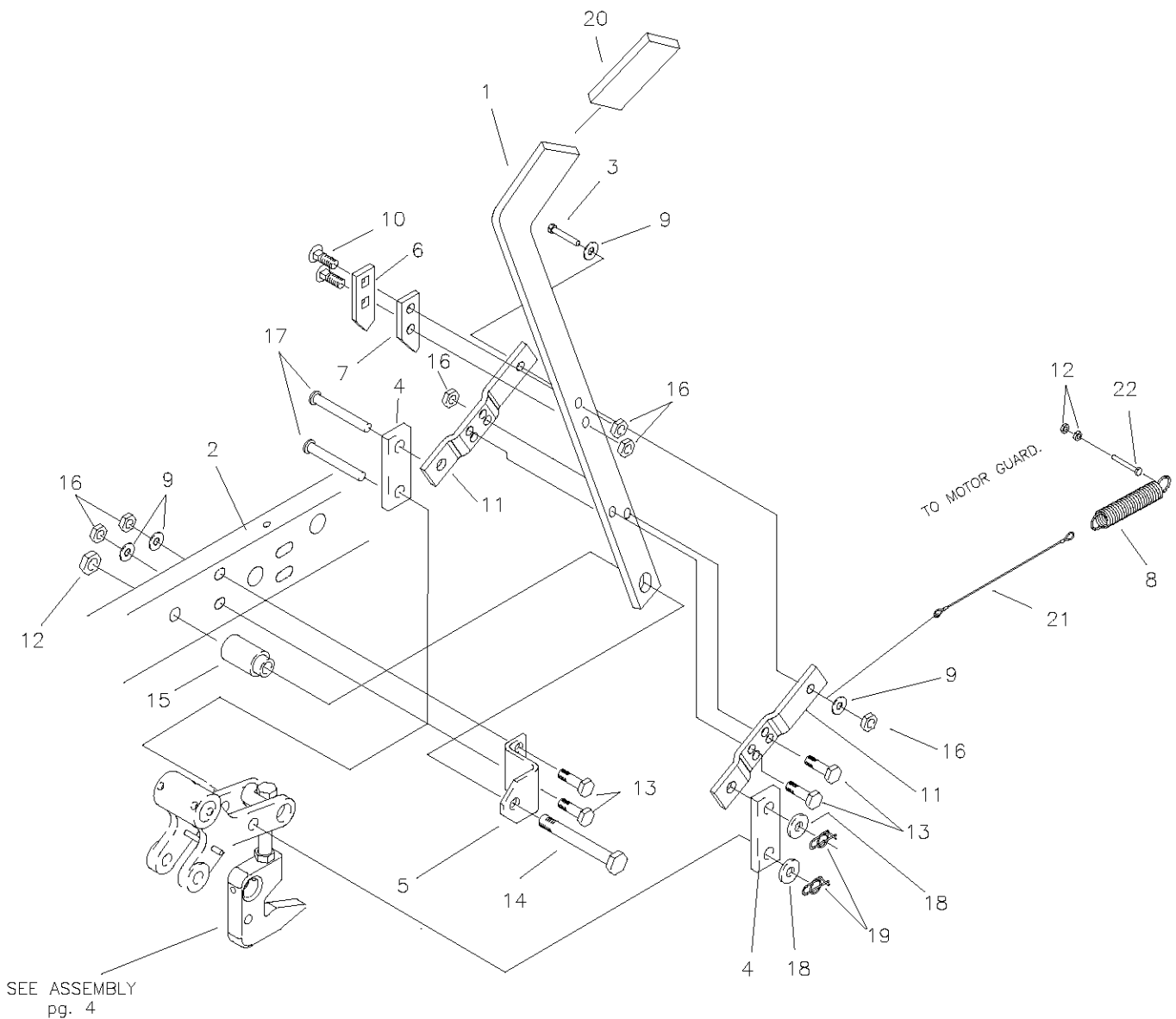

ITEM #	PART #	QTY	DESCRIPTION	ITEM #	PART #	QTY	DESCRIPTION
1	659-060P	1	LIFT HANDLE	15	642-095P	1	HANDLE PIVOT PIN
2	659-022W	1	FRAME WELDMENT, LH.	16	F-1005-03	6	NUT, 3/8-16 LOCKNUT (STOVER)
3	F-1073	1	3/8-18 X 2" GR 5	17	F-1889	2	CLEVIS PIN, 1/2 X 2 5/8"
4	642-061P	2	HANDLE LINK	18	F-1521	2	1/2" FLAT WASHER
5	642-041P	1	HANDLE PIVOT BRACKET	19	H-2239	2	RUE RING, 1/2"
6	642-127P	1	TOP PEG LATCH PLATE	20	H-2324	1	VINYL GRIP, 3/8 X 1 1/2"
7	642-126P	1	TOP PEG SPACER PLATE	21	H-2460	1	CABLE
8	H-1610	1	SPRING, 1 1/2" OD. X 8"	22	F-1293	2	1/2-13 X 1 1/2" GR. 5
9	F-1009-03	3	FLAT WASHER, 3/8"				
10	F-1672	2	CARRIAGE BOLT, 3/8-16 X 1 1/4"				
11	642-060P	2	SPRING ANCHOR PLATE				
12	F-1005-05	3	NUT, 1/2-13 LOCKNUT				
13	F-1307	2	3/8-16 X 1 1/4" GR. 5				
14	F-1439	1	1/2-13 X 3" GR. 5				

LIFT ASSEMBLY & RELATED PARTS

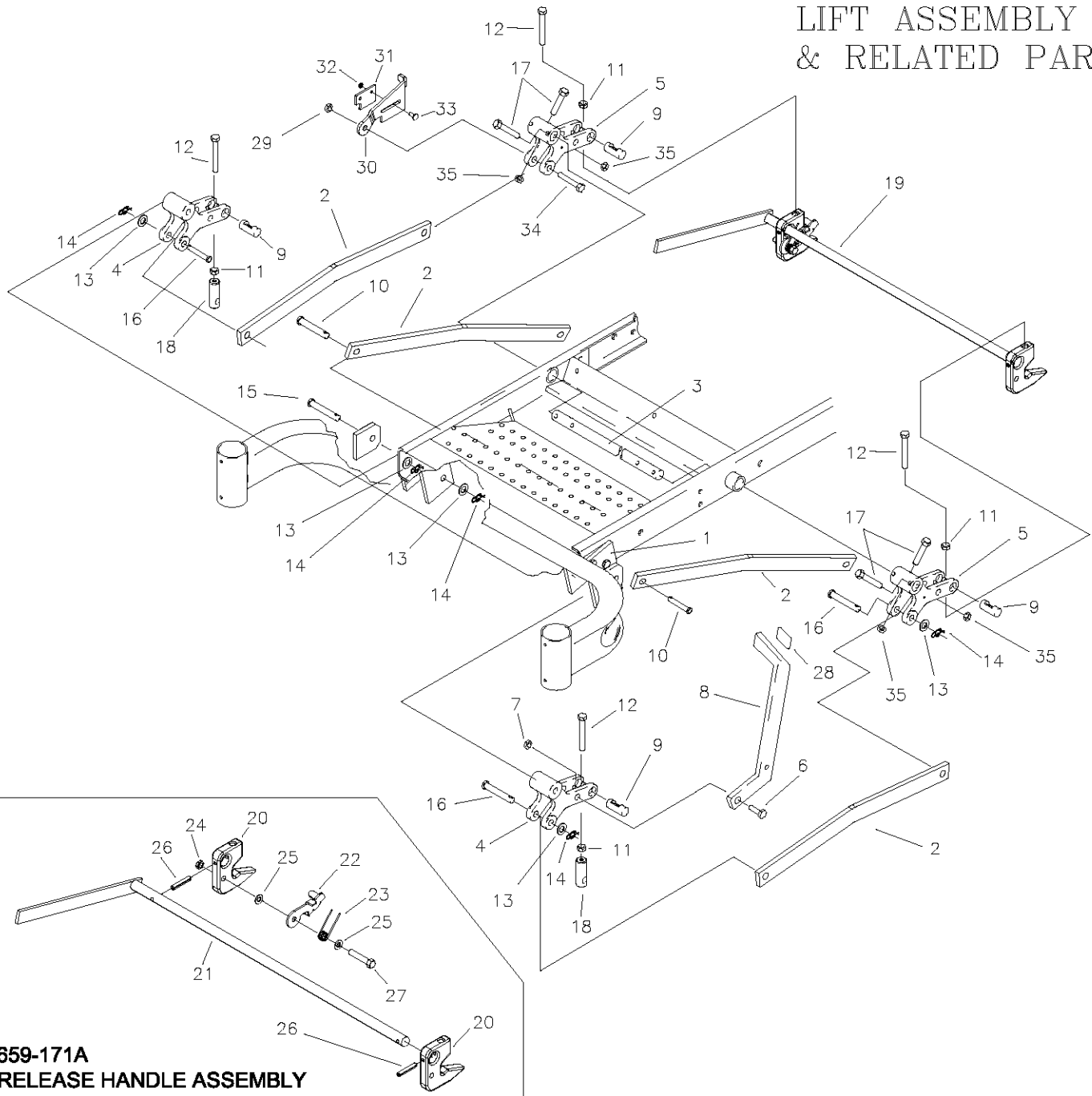

**659-171A
RELEASE HANDLE ASSEMBLY**

ITEM #	PART #	QTY	DESCRIPTION	ITEM #	PART #	QTY	DESCRIPTION
1	642-063P	2	DRAG BAR TAB	19	659-171A	1	RELEASE HANDLE ASSEMBLY
2	659-155P	4	DRAG LINK BAR	20	659-140P	2	DECK HOOK
3	620-051P	1	LIFT BAR	21	659-148W	1	RELEASE HANDLE WELDMENT
4	642-081P	2	LIFT SLEEVE, FRONT	22	659-145P	1	HOOK KEEPER
5	642-082P	2	LIFT SLEEVE, REAR	23	H-2547	1	SPRING, TORSION
6	F-1879	1	5/16-18 X 1 1/4" GR.5	24	F-1005-03	1	NUT, 3/8-16, STOVER
7	F-1125	1	5/16-18 STOVER NUT	25	F-1009-03	2	WASHER, FLAT, 3/8"
8	659-056P	1	DECK LIFT PEDAL	26	F-2009	2	SPIROL ROLL PIN 1/4 X 1-1/2
9	642-177P	4	HANGER PIN	27	F-1073	1	CAPSCREW, 3/8-16 X 2, GR. 5
10	F-1815	2	CLEVIS PIN, 1/2 X 1 1/4"	28	H-2401	1	TREAD PAD
11	F-1489	4	NUT, 1/2" JAM	29	F-1005-05	1	1/2" STOVER NUT
12	F-1936	4	1/2-13 X 3 1/2, 2" THREAD	30	659-146P	1	LATCH PLATE
13	F-1521	8	WASHER, 1/2 NARROW	31	659-170P	1	PLATE, CATCH
14	H-2239	8	RUE RING, 1/2"	32	F-1158	2	NUT, 1/4" STOVER
15	H-2240	2	CLEVIS PIN, 1/2 X 4 1/2"	33	F-1823	2	CARRIAGE BOLT, 1/4-20 X 3/4"
16	F-1898	3	CLEVIS PIN, 1/2 X 2 3/4"	34	F-1828	1	1/2-13 x 3-1/2" CAPSCREW
17	F-2039	4	5/16-24 x 2" HHCS	35	F-2041	4	5/16-24 JAM NUT
18	642-175P	2	ADJUSTABLE HANGER END				

TRANSMISSION IDLERS & RELATED PARTS

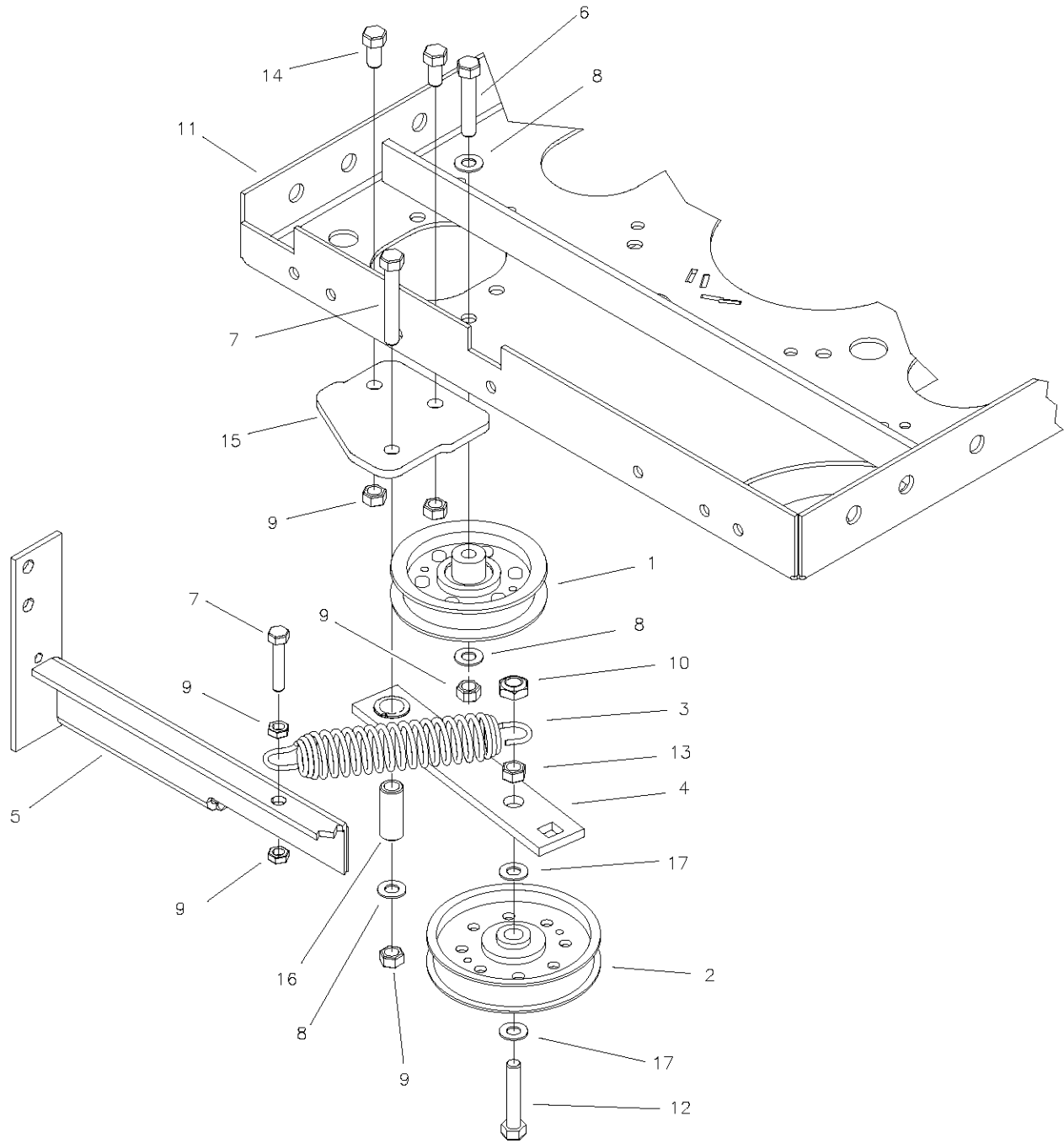

ITEM #	PART #	QTY	DESCRIPTION	ITEM #	PART #	QTY	DESCRIPTION
1	D-3768	1	PULLEY, 3-1/2" X 1"	15	659-239P	1	BOLT ON IDLER MOUNT TAB
2	D-3617	1	PULLEY, FLAT IDLER, 1/2" BORE, 4"	16	659-085P	1	MOUNTING PIN
3	H-2619	1	SPRING, 5x1-1/2, TAPERED ENDS	17	F-1521	2	1/2" FLAT WASHER
4	661-090A	1	IDLER ARM ASSEMBLY				
5	659-296W	1	BRACE WELDMENT				
6	F-1073	1	3/8-16 x 2" CAPSCREW				
7	F-1015-30	2	3/8-16 X 2-1/2" GR. 5				
8	F-1009-03	2	3/8" FLAT WASHER				
9	F-1005-03	6	3/8-16 STOVER LOCK NUT				
10	F-1966	1	1/2" THIN NYLOC NUT				
11	659-174W	1	MOTOR MOUNT WELDMENT				
12	F-1664	1	1/2-13 x 2-1/4" CAPSCREW				
13	F-1005-05	1	1/2-13 STOVER NUT				
14	F-1015-23	2	3/8-16 x 3/4" CAPSCREW				

CASTER WHEEL ASSEMBLY

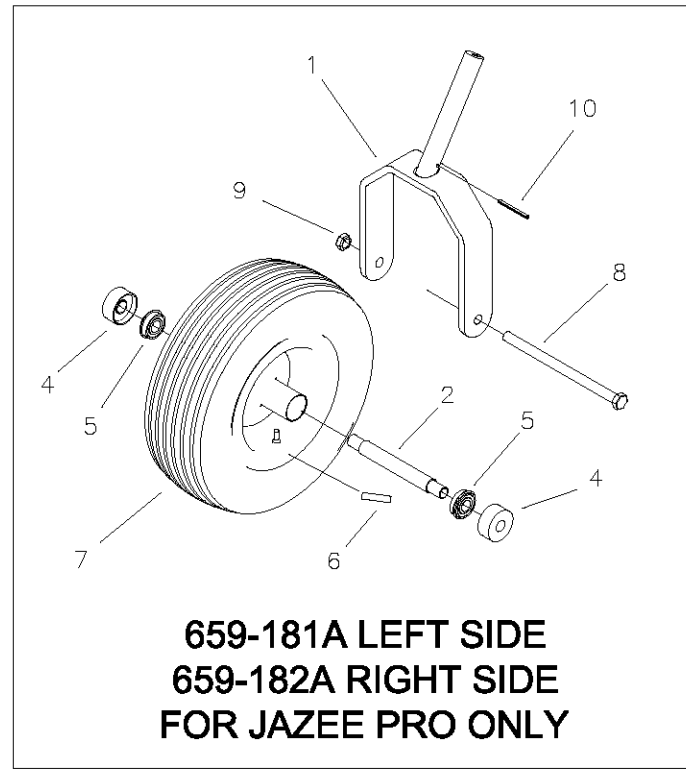
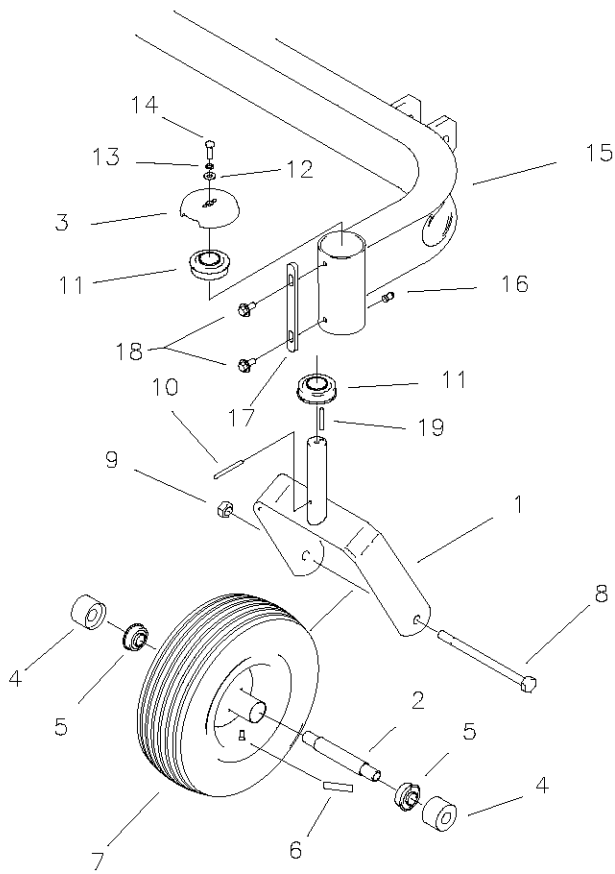

NOTE:

REF. NO. 3 IS SHOWN IN REFERENCE POSITION FOR CLARITY. WHEN INSTALLING, THE NOTCH SHOULD POINT TOWARDS THE BACK OF MOWER

ITEM #	PART #	QTY	DESCRIPTION
1	659-184W	2	CASTER WELDMENT FOR JAZEE
-	617-375W	2	CASTER WELDMENT FOR JAZEE PRO
2	622-121P	2	BEARING SPACER
-	611-136P	2	BEARING SPACER, JAZEE PRO
3	636-176P	2	BEARING CAP, RED
4	659-004P	4	BEARING SHIELD
-	611-135P	4	BEARING SHIELD, JAZEE PRO
5	D-3432	4	BEARING, 5/8 ID X 1-3/8 OD
6	P-11384	2	DECAL, 12 PSI
7	D-3605	2	10" TIRE, W/RIM
-	D-3574	-	TIRE, 13" W/ WHEEL, JAZEE PRO
8	F-1492	2	1/2-13 X 6-1/2" GR. 5 BOLT
-	F-1129	2	1/2-13 X 8" GR. 5 BOLT
9	F-1005-05	2	1/2-13 LOCK NUT
10	F-1456	2	3/16" X 2" ROLL PIN
11	D-2008-02	4	BEARING, SPD SF-16-32
12	F-1009-02	2	5/16" FLAT WASHER
13	F-1019-02	2	5/16" LOCK WASHER
14	F-1863	2	5/16"-18 X 1" W/NYLOC PATCH
15	659-298W	1	FRONT AXLE WELDMENT FOR JAZEE
-	659-287W	1	FRONT AXLE WELDMENT FOR JAZEE PRO
16	H-1056	2	GREASE ZERK
17	659-185P	2	STOP TAB
18	F-2030	4	1/4" X 5/8" SELF TAPPING SCREW
19	F-1855	2	3/16" X 1" ROLL PIN

FRAME SIDES & RELATED PARTS FOR JAZEE SR220

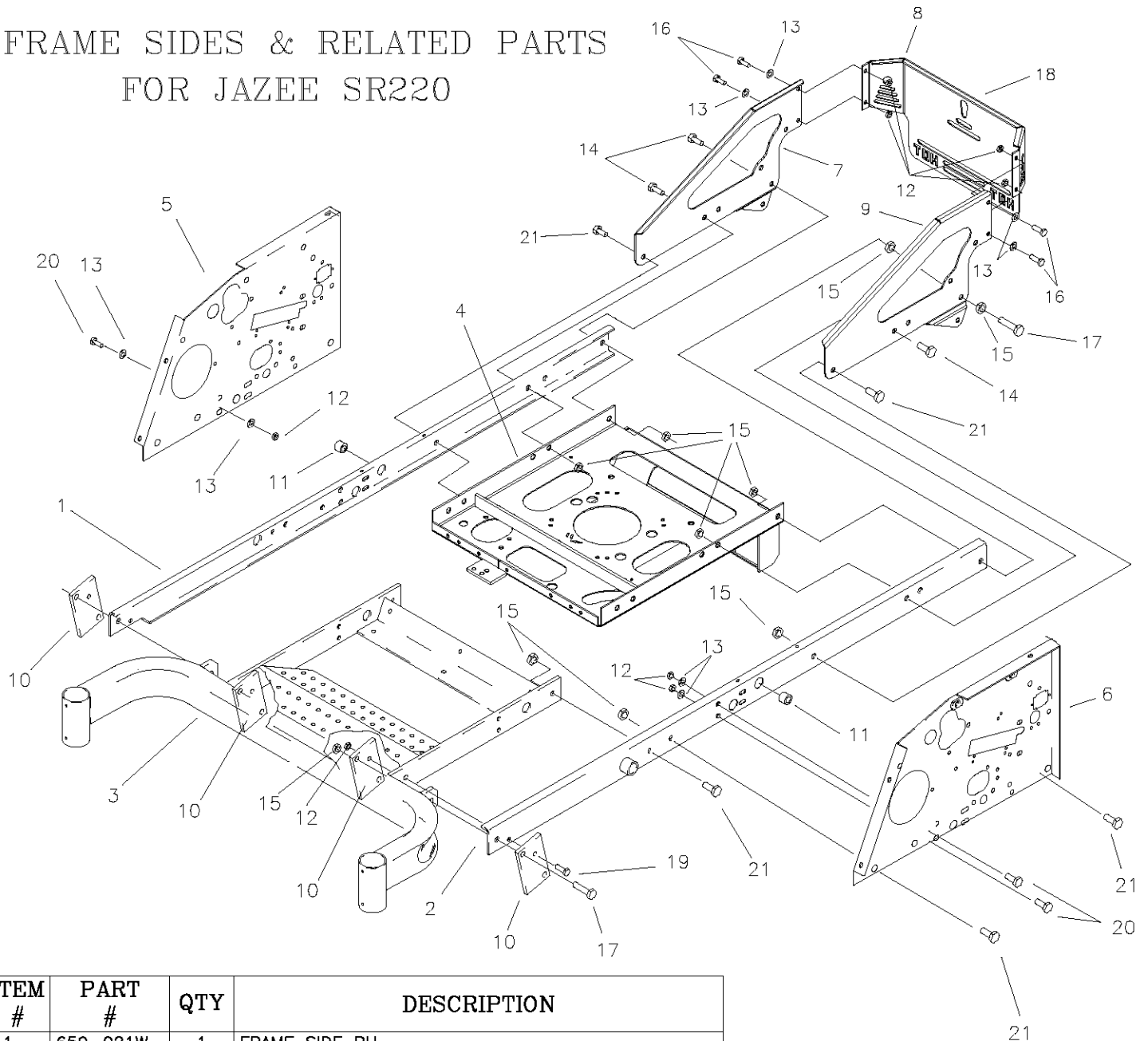

ITEM #	PART #	QTY	DESCRIPTION
1	659-021W	1	FRAME SIDE RH.
2	659-022W	1	FRAME SIDE LH.
3	659-298W	1	AXLE MOUNTING WELDMENT
4	700-024W	1	MOTOR MOUNT WELDMENT
5	659-209W	1	SIDE PANEL RH. (JOYSTICK)
-	659-253W	1	SIDE PANEL LH. (TWINSTICK)
6	659-202P	1	SIDE PANEL RH. (JOYSTICK)
-	659-255P	1	SIDE PANEL LH. (TWINSTICK)
7	659-133P	1	ENGINE GUARD RH SIDE PANEL
8	659-164A	1	SINGLE CYLINDER REAR PANEL-W/DECAL
9	659-134P	1	ENGINE GUARD LH SIDE PANEL
10	642-063P	4	DRAG BAR TAB
11	D-3730	2	BUSHING, 5/8 BORE (JOYSTICK ONLY)
12	F-1005-03	10	3/8-16 STOVER NUT
13	F-1009-03	10	3/8 FLAT WASHER
14	F-1759	3	1/2-13 X 1" GR.5
15	F-1005-05	17	1/2-13 LOCK NUT
16	F-1558	4	3/8-16 X 7/8" GR.5
17	F-1293	3	1/2-13 X 2", GR.5
18	P-12097	1	COLORED DECAL, "COUNTRY CLIPPER"
19	F-1073	2	3/8-16 x 2" CAPSCREW
20	F-1394	4	3/8-16 x 1" CAPSCREW
21	F-1386	6	1/2-13 x 1-1/4" CAPSCREW

FRAME SIDES &
RELATED PARTS
FOR JAZEE PRO SR370

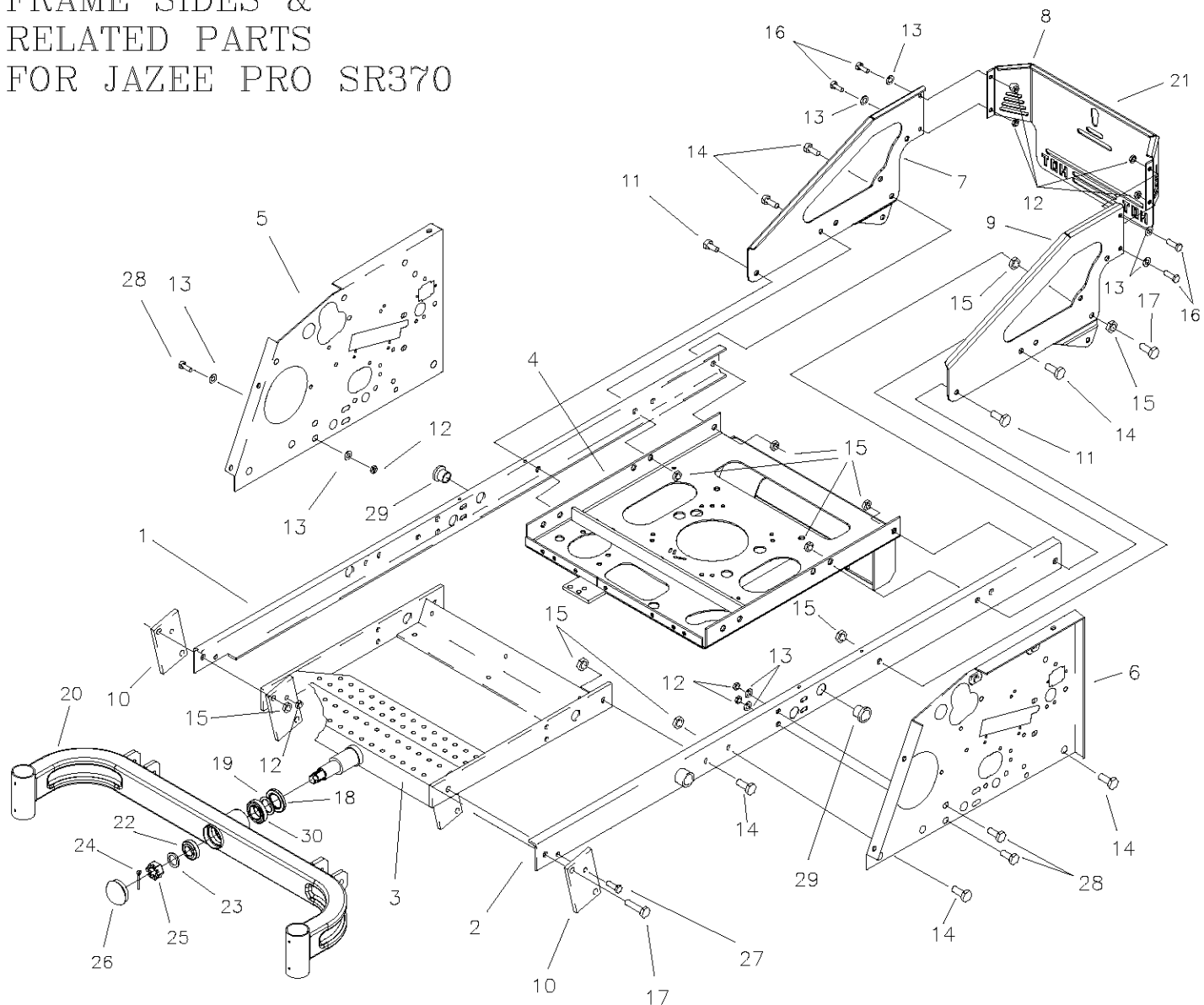

ITEM #	PART #	QTY	DESCRIPTION	ITEM #	PART #	QTY	DESCRIPTION
1	659-021W	1	FRAME SIDE RH.	18	H-2600	1	SEAL, SHAFT, 1.50, 2.38, 0.313
2	659-022W	1	FRAME SIDE LH.	19	663-074P	1	RING, BACKUP, STEEL
3	663-094W	1	AXLE MOUNTING WLDT.	20	659-287W	1	FRONT AXLE WLDT.
4	659-174W	1	MOTOR MOUNT WLDT.	21	P-12097	1	COLORLED DECAL, "COUNTRY CLIPPER"
5	659-209W	1	SIDE PANEL RH. (JOYSTICK)	22	D-3826	1	BRG, TAPARED, SET
-	659-253W	1	SIDE PANEL RH. (TWINSTICK)	23	606-303P	1	1" WASHER
6	659-202P	1	SIDE PANEL LH. (JOYSTICK)	24	F-1728	1	3/16 X 2" COTTER PIN
-	659-255P	1	SIDE PANEL LH. (TWINSTICK)	25	F-1724	1	1-14 SLOTTED NUT
7	659-133P	1	ENGINE GUARD RH SIDE PANEL	26	H-1924	1	GREASE CAP
8	647-123A	1	REAR PANEL-W/DECAL	27	F-1073	2	3/8-16 x 2" CAPSCREW
9	659-134P	1	ENGINE GUARD LH SIDE PANEL	28	F-1394	4	3/8-16 x 1" CAPSCREW
10	642-063P	2	DRAG BAR TAB	29	D-3730	2	BUSHING 5/8 BORE (JOYSTICK ONLY)
11	F-1386	2	1/2-13 x 1-1/4" CAPSCREW	30	D-3825	1	BRG, TAPPERED, SET
12	F-1005-03	10	3/8-16 STOVER NUT				
13	F-1009-03	10	3/8 FLAT WASHER				
14	F-1759	12	1/2-13 X 1" GR.5				
15	F-1005-05	12	1/2-13 LOCK NUT				
16	F-1558	4	3/8-16 X 7/8" GR.5				
17	F-1293	3	1/2-13 X 2", GR.5				

FENDER ASSEMBLY

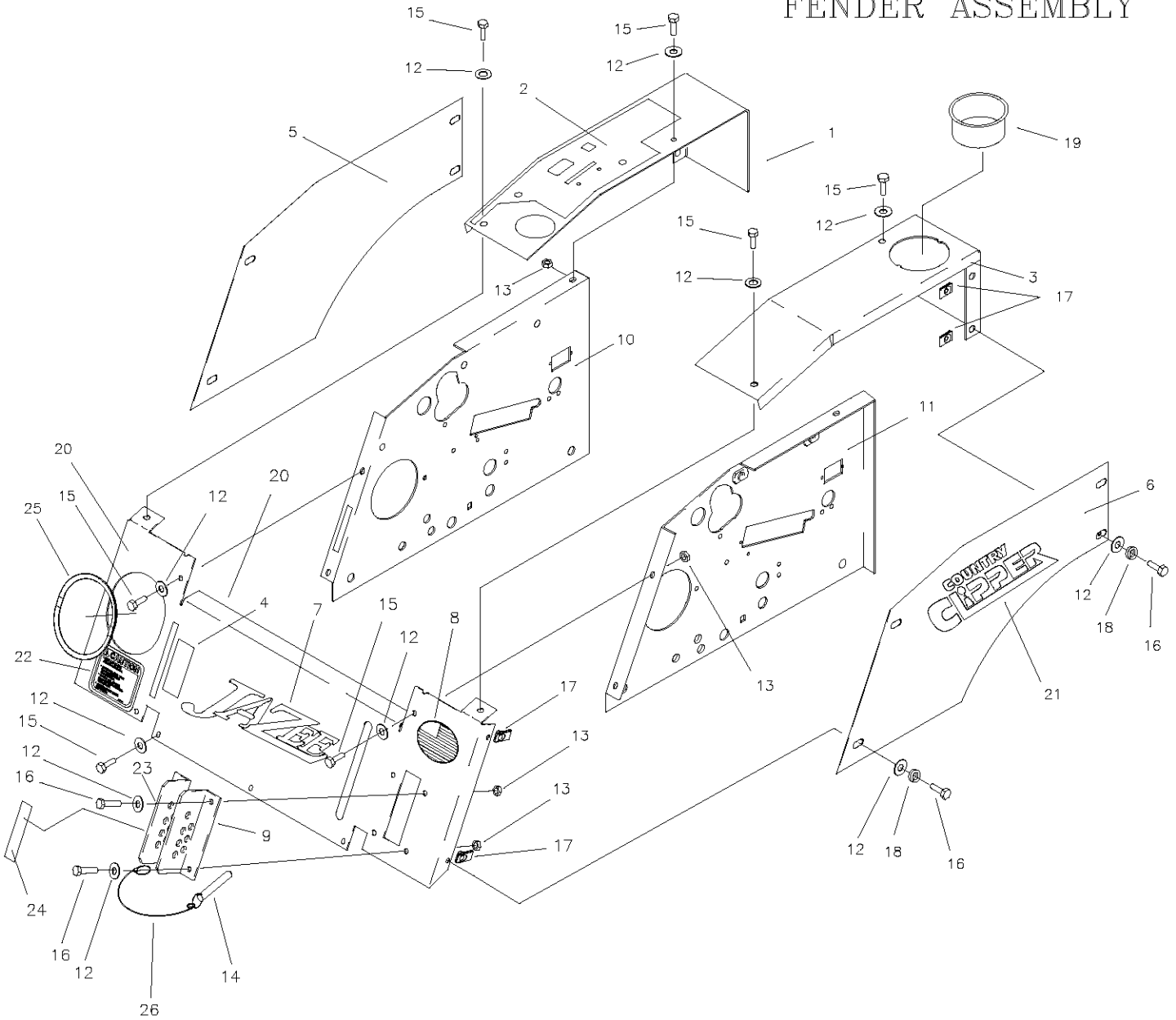

ITEM #	PART #	QTY	DESCRIPTION	ITEM #	PART #	QTY	DESCRIPTION
1	659-312A	1	FENDER, RH (JOYSTICK)-W/DECAL	14	F-2028	1	1/2" X 3" CLEVIS PIN
-	659-313A	1	FENDER, RH (TWINSTICK)-W/DECAL	15	F-1546	4	5/16-18 X 3/4" GR. 5
2	P-11626	1	DECAL, "CONTROL PANEL"	16	F-1015-15	18	5/16-18 X 1" GR.5
3	659-263P	1	FENDER CAP LH. (JOYSTICK)	17	F-1860	8	5/16 U-NUT
-	659-257P	1	FENDER CAP LH. (TWINSTICK)	18	F-1019-02	8	5/16 LOCK WASHER
4	P-11382	1	DECAL, PARK BRAKE	19	H-2228	1	CUP HOLDER
5	659-188A	1	FENDER SKIRT RH-W/DECAL	20	663-310A	1	JAZEE PANEL-W/DECAL
6	659-189A	1	FENDER SKIRT LH-W/DECAL	-	663-311A	1	JAZEE PRO PANEL-W/DECAL
7	P-11624	1	DECAL, JAZEE	21	P-12097	2	DECAL, "COUNTRY CLIPPER"
-	P-12063	1	DECAL, JAZEE PRO	22	P-12557	1	DECAL, "CAUTION"
8	P-12253	1	MADE IN THE USA DECAL	23	642-128P	1	LATCH PLATE
9	642-129P	1	LATCH PLATE LH.	24	P-12257	1	DECAL, "CUT HEIGHT"(JAZEE SR220)
10	659-209W	1	SIDE PANEL RH. (JOYSTICK)	-	P-12039	1	DECAL, "CUT HEIGHT"(JAZEE PRO SR370)
-	659-253W	1	SIDE PANEL RH. (TWINSTICK)	25	H-1626	1	"U"-CHANNEL TRIM
11	659-202P	1	SIDE PANEL LH. (JOYSTICK)	26	F-2069	1	PLASTIC LANYARD
-	659-255P	1	SIDE PANEL LH. (TWINSTICK)				
12	F-1009-02	22	5/16 FLAT WASHER				
13	F-1125	16	5/16-18 LOCK NUT				

SEAT, FOOTDECK & RELATED PARTS

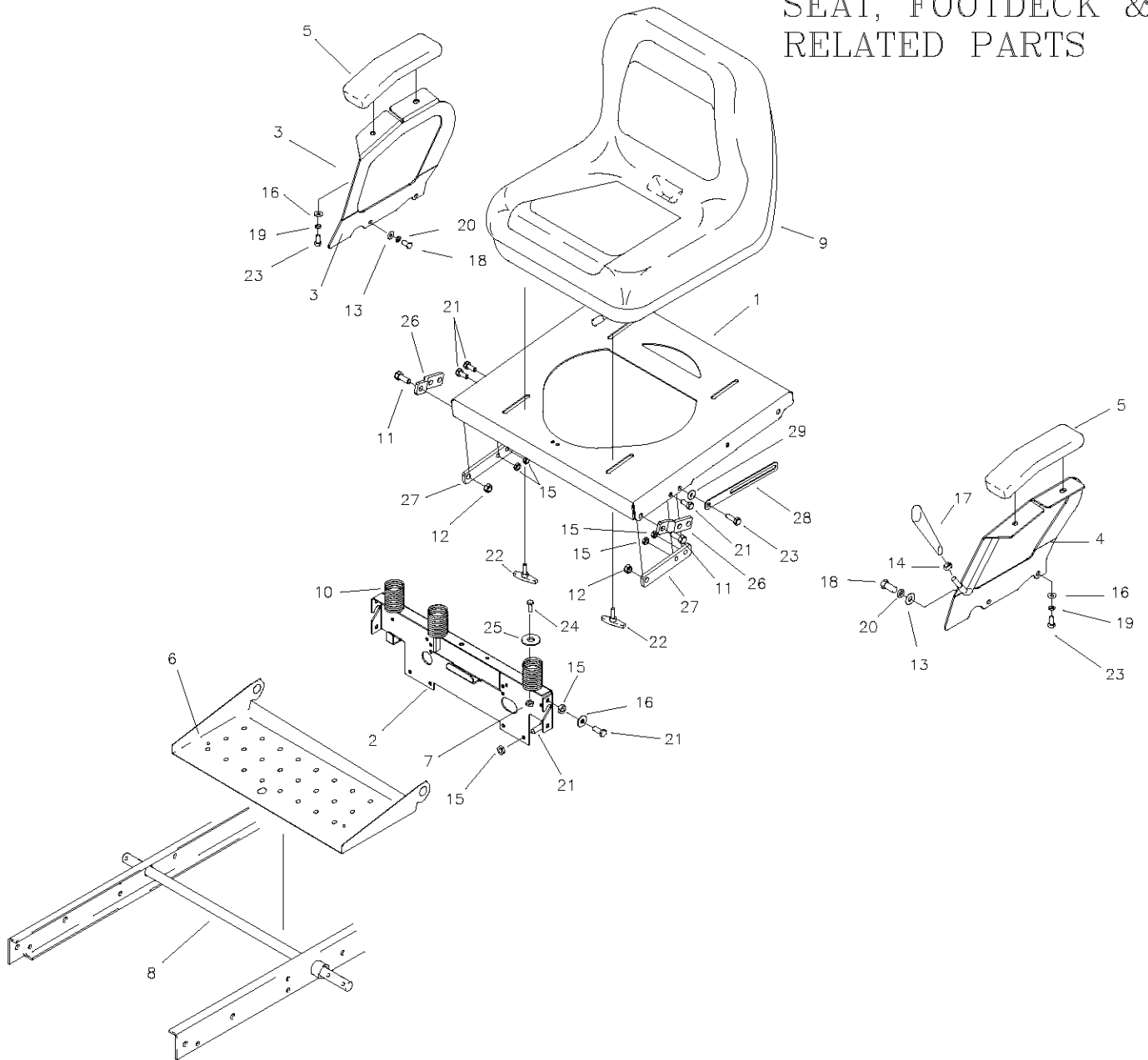

ITEM #	PART #	QTY	DESCRIPTION	ITEM #	PART #	QTY	DESCRIPTION
1	659-005P	1	SEAT MOUNTING BASE (20hp JAZEE ONLY)	13	F-1009-03	4	3/8 FLAT WASHER
-	659-265P	1	SEAT MOUNTING BASE	14	F-1486	1	3/8-16 JAM NUT
2	659-136P	1	REAR SEAT BRACE	15	F-1125	13	5/16-18 LOCK NUT
3	659-051P	1	ARM REST RH. (20HP JAZEE JOYSTICK)	16	F-1009-02	8	5/16 FLAT WASHER
-	659-266P	1	ARM REST RH. (JOYSTICK & TWINSTICK)	17	H-2317	1	TAPERED HANDLE
-	636-163P	1	ARM REST LH. (20HP JAZEE TWINSTICK)	18	F-1015-23	4	3/8-16 X 3/4" GR. 5
4	659-055W	1	ARM REST LH. (20HP JAZEE JOYSTICK)	19	F-1019-02	4	5/16 LOCK WASHER
-	636-163P	1	ARM REST LH. (20HP JAZEE TWINSTICK)	20	F-1019-03	4	3/8 LOCK WASHER
-	659-267P	1	ARM REST LH. (TWINSTICK)	21	F-1546	12	5/16-18 X 3/4" GR. 5
-	659-268W	1	ARM REST LH. (JOYSTICK)	22	659-073A	4	T-HANDLE ASSEMBLY
5	621-143A	2	ARM REST PAD (20HP JAZEE)	23	F-1015-15	5	5/16-18 X 1" GR. 5
-	H-2615	2	ARM REST PAD	24	F-1538	3	1/4-20 X 3/4", GR.5
6	659-006P	1	FOOT PANEL	25	620-050P	3	1" HEAVY WASHER
7	F-1158	3	1/4" STOVER NUT	26	647-086P	2	FLIP SEAT MATING TAB
8	620-051P	1	LIFT BAR	27	659-175P	2	SEAT HINGE TAB
9	H-2449	1	SEAT ASSEMBLY (20HP JAZEE)	28	659-272P	1	BAR, SEAT STOP
-	H-2604	1	SEAT ASSEMBLY	29	659-274P	1	PIVOT WASHER
10	H-1920	3	SEAT SPRING				
11	F-1394	2	3/8-16 X 1 1/4" GR. 5				
12	F-1005-03	2	3/8-16 LOCK NUT				

FRONT STEP ASSEMBLY FOR JAZEE PRO SR370

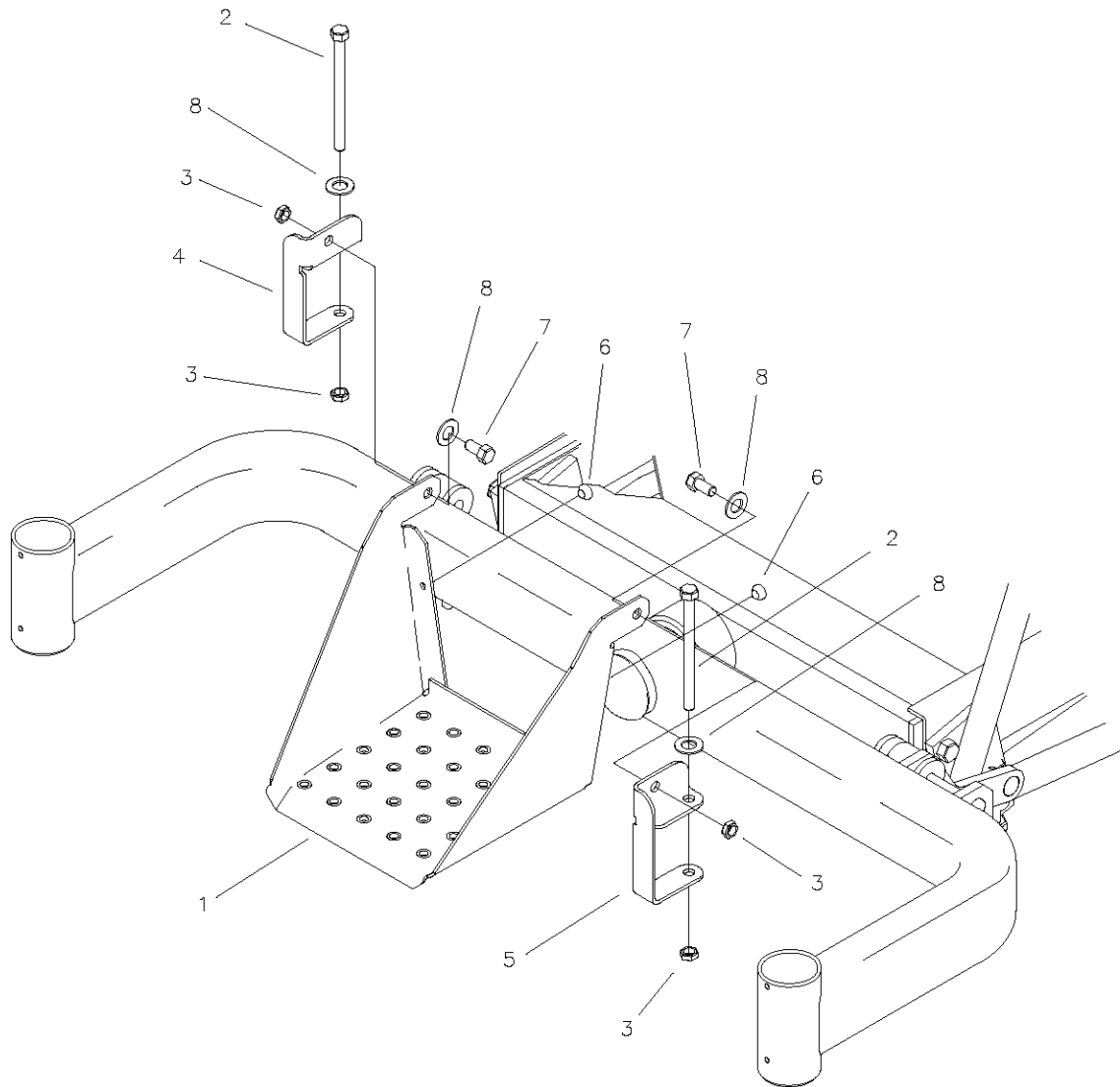

ITEM #	PART #	QTY	DESCRIPTION
1	647-133P	1	FRONT STEP
2	F-1066	2	3/8-16 X 4" BOLT
3	F-1005-03	4	3/8-16 LOCK NUT
4	659-241P	1	STEP MOUNT BRACKET, RH
5	659-242P	1	STEP MOUNT BRACKET, LH
6	H-2461	2	RUBBER BUMPER BUTTON
7	F-1015-23	2	3/8-16 X 3/4" BOLT
8	F-1009-03	4	3/8 FLAT WASHER

FUEL TANK & RELATED PARTS

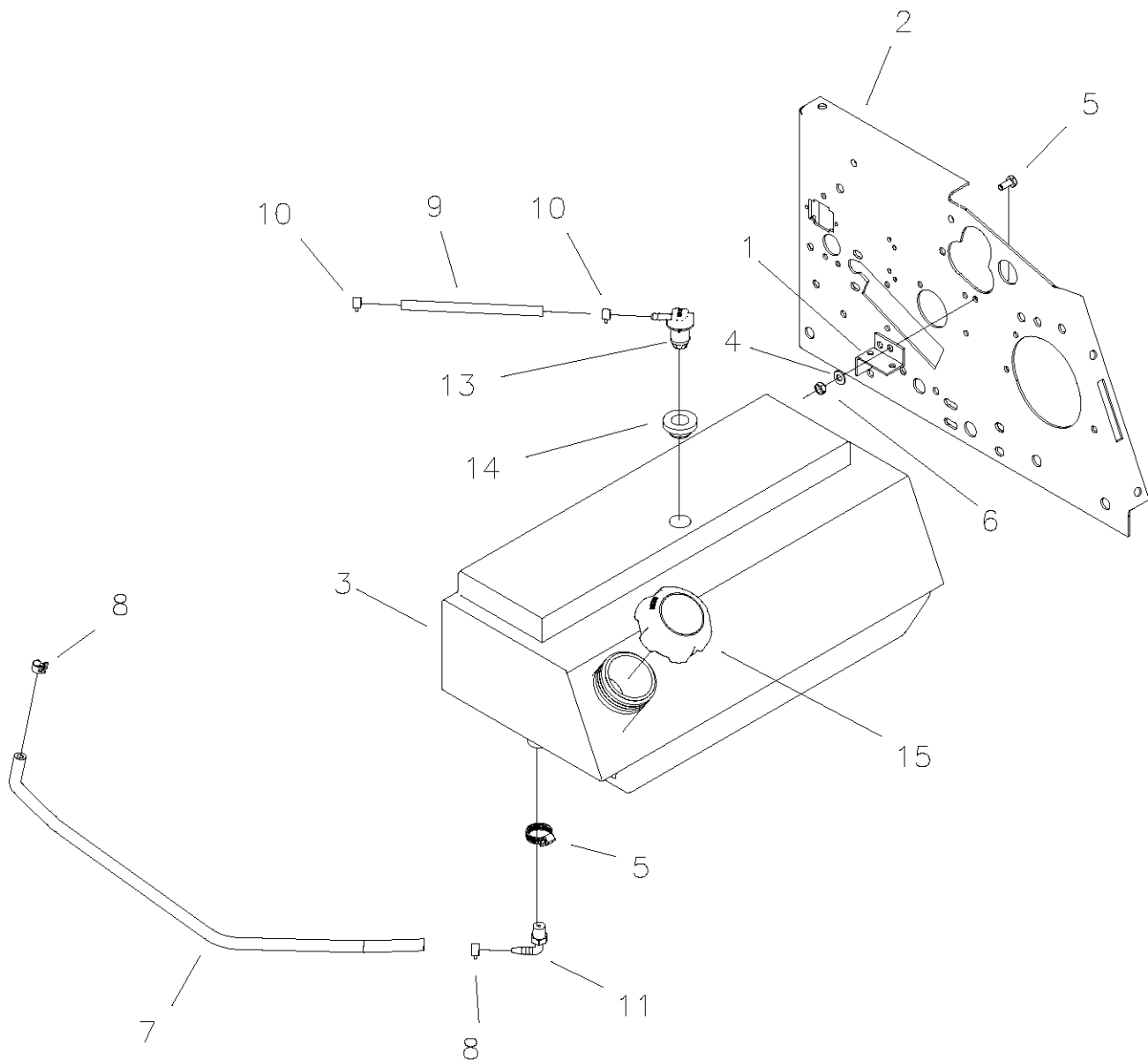

ITEM #	PART #	QTY	DESCRIPTION
1	659-066P	1	Tank Mount Clamp
2	659-202P	1	SIDE PANEL LH
3	H-2677	1	Fuel Tank (ASS'Y 659-306A)
4	F-1009-01	1	1/4" Flat Washer
5	F-1015-02	1	1/4-20 x 5/8" Capscrew
6	F-1158	1	1/4-20 Stover Nut
7	H-1648	1	Fuel Line
8	H-1687	2	1/2 O.D. Hose Spring Clamp
9	H-2697	1	VENT LINE
10	H-2698	2	HOSE CLAMP, .406 OD
11	H-1646	1	HOSE BARB 90 DEG.
12	H-1952	1	HOSE CLAMP
13	H-2678	1	REMOTE VENT
14	H-2698	2	REMOTE VENT GROMMET
15	H-2687	1	GAS CAP

JOYSTICK STEERING CONTROL & RELATED PARTS

NOTE: ITEM'S #2 AND #3 MUST BE REPLACED AT THE SAME TIME FOR MAXIMUM PERFORMANCE.

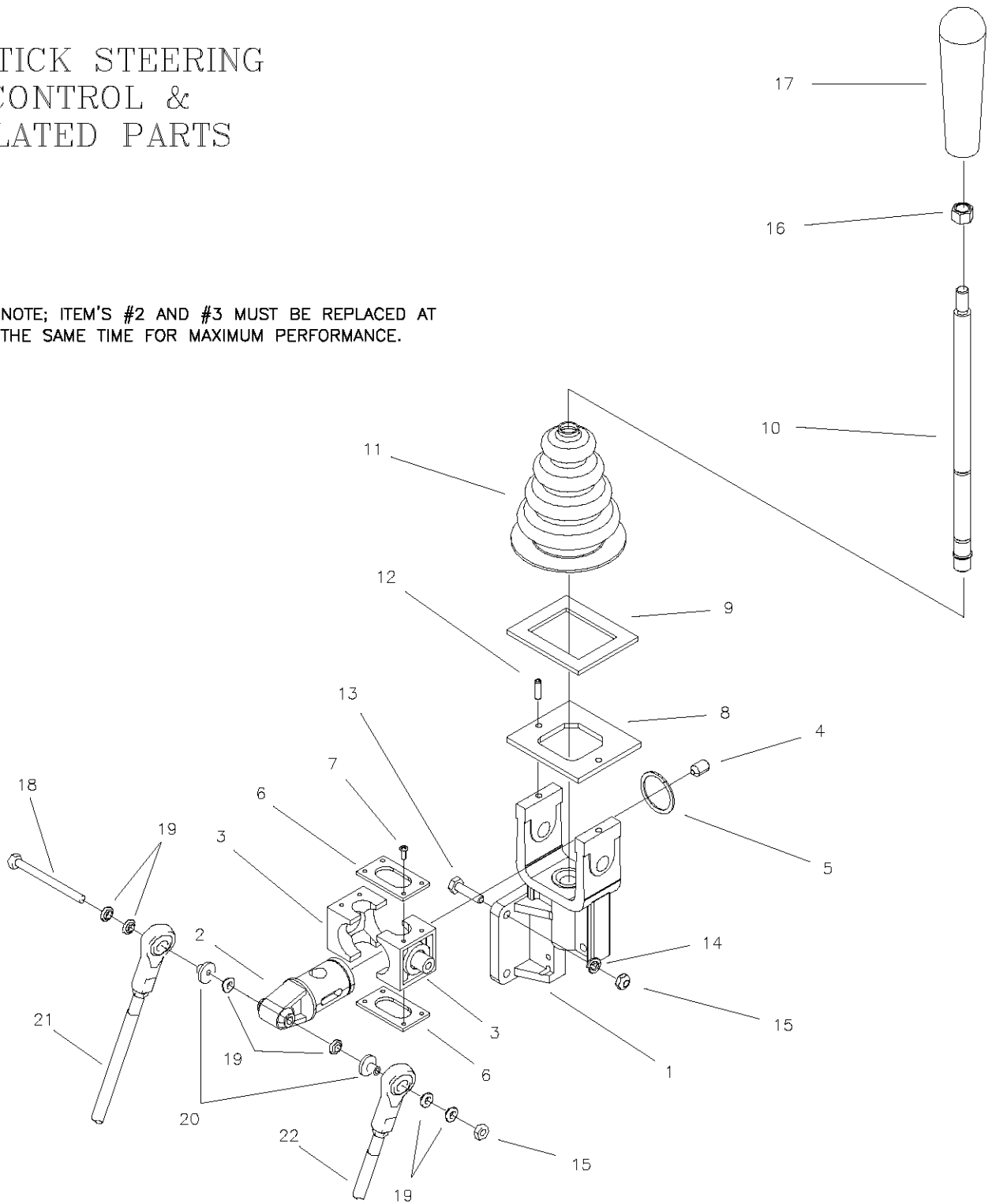

ITEM #	PART #	QTY	DESCRIPTION	ITEM #	PART #	QTY	DESCRIPTION
-	647-122A	1	JOYSTICK ASSEMBLY	12	F-1999	2	ROLL PIN, 3/16 X 5/8
1	659-144P	1	JOYSTICK YOKE	13	F-1015-05	3	1/4-20 X 1" HHCS GR. 5
2	H-1992	1	PIVOT SHAFT	14	F-1019-01	3	1/4" LOCK WASHER
3	H-1993	2	PIVOT BLOCK	15	F-1158	4	1/4-20 Stover Nut
4	F-1120	1	BALL PLUNGER	16	F-1011-03	1	3/8-16 NUT, JAM
5	H-1997	1	SNAP RING, SPIRLOCK	17	H-2317	1	GRIP, HANDLE
6	619-306P	2	PIVOT BLOCK PLATE	18	F-1020-01	1	1/2-20 X 3-1/2" GR. 5
7	F-1624	8	#6-32 X 3/8" SCREW SLOT	19	H-1989	6	BUSHING, BALL JOINT
8	659-129P	1	JOYSTICK TOP PLATE	20	H-2465	2	1/4" SPACER
9	H-1947	1	GASKET, FOAM	21	663-049P	1	UPPER STEERING LINKAGE
10	621-140A	1	JOYSTICK SHAFT ASSEMBLY	22	663-050P	1	STEERING LINKAGE
11	H-1991	1	BOOT, BELLOWS				

JOYSTICK STEERING CONTROL & RELATED PARTS FOR JAZEE SR220 & JAZEE PRO SR370

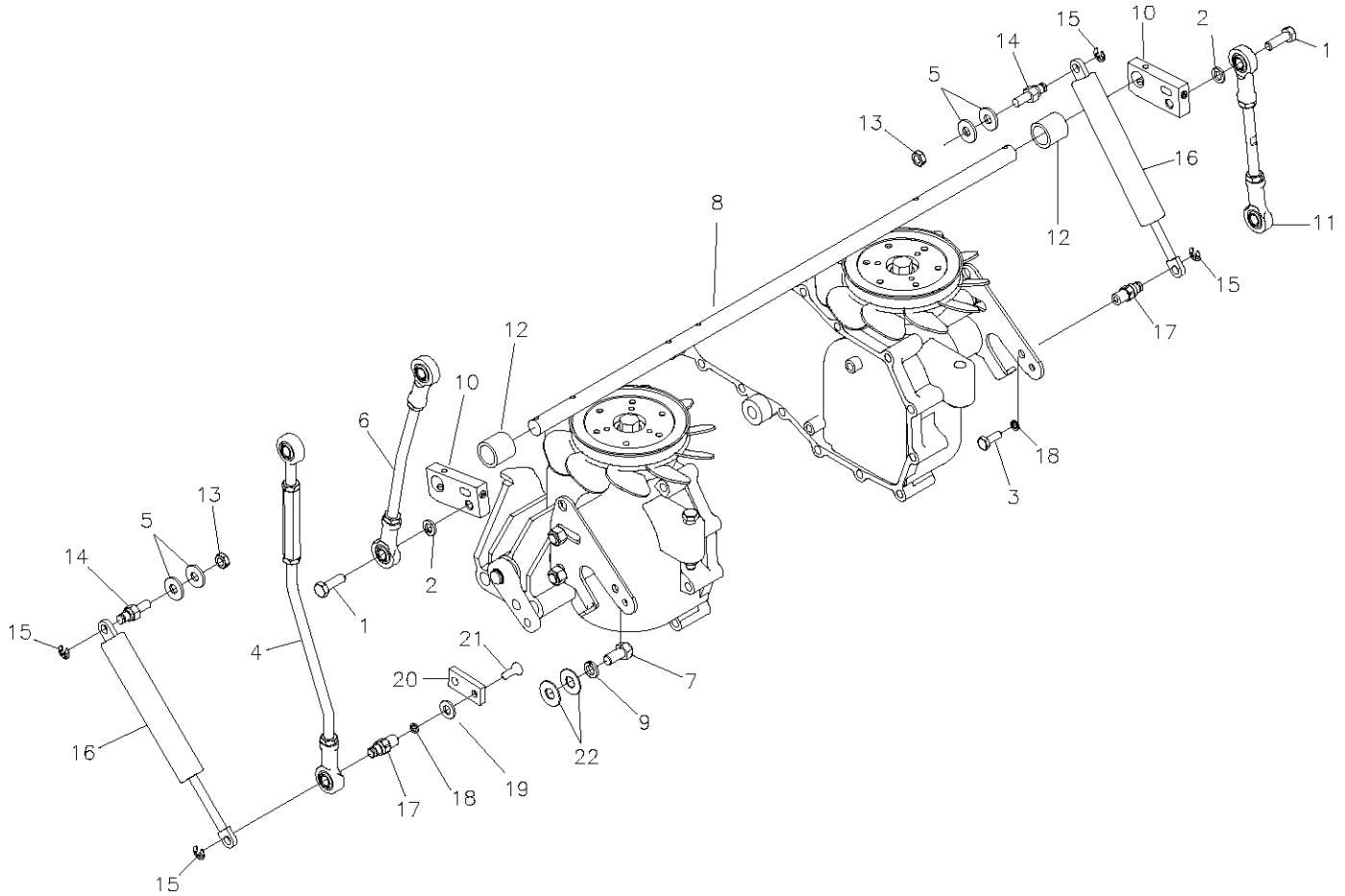

ITEM #	PART #	QTY	DESCRIPTION	ITEM #	PART #	QTY	DESCRIPTION
1	F-1015-15	2	5/16-18 x 1" CAPSCREW	15	F-1610	4	E-RING FOR 1/4" SHAFT
2	F-1019-02	2	5/16" LOCKWASHER	16	H-2467	2	DUAL ACTION DAMPNER
3	F-1538	1	1/4-20 X 3/4" CAPSCREW	17	663-051P	2	DAMPER STUD (FEMALE)
4	663-050P	1	STEERING LINKAGE	18	F-1019-01	2	1/4" LOCKWASHER
5	F-1009-02	4	5/16" FLAT WASHER	19	F-1009-01	1	1/4" FLAT WASHER
6	663-049P	1	UPPER STEERING LINKAGE	20	659-275P	1	TRACKING ADJUSTMENT BLOCK
7	F-1015-23	1	3/8-16 x 3/4 H.H.C.S.	21	F-1609	1	1/4-20 x 3/4" F.H.C.S.
8	659-026P	1	HYDRO SHAFT ROD	22	F-1009-03	2	3/8" FLAT WASHER
9	F-1019-03	1	3/8" LOCKWASHER				
10	625-091A	2	SWIVEL ARM				
11	659-127P	1	LOWER STEERING LINKAGE				
12	651-024P	2	SPACER				
13	F-1125	2	5/16-16 STOVER NUT				
14	638-028P	2	DAMPER BOLT, 5/16-18 x 3/4				

TWINSTICK STEERING CONTROL & RELATED PARTS

(RIGHTHAND SHOWN, LEFTHAND OPPOSITE)

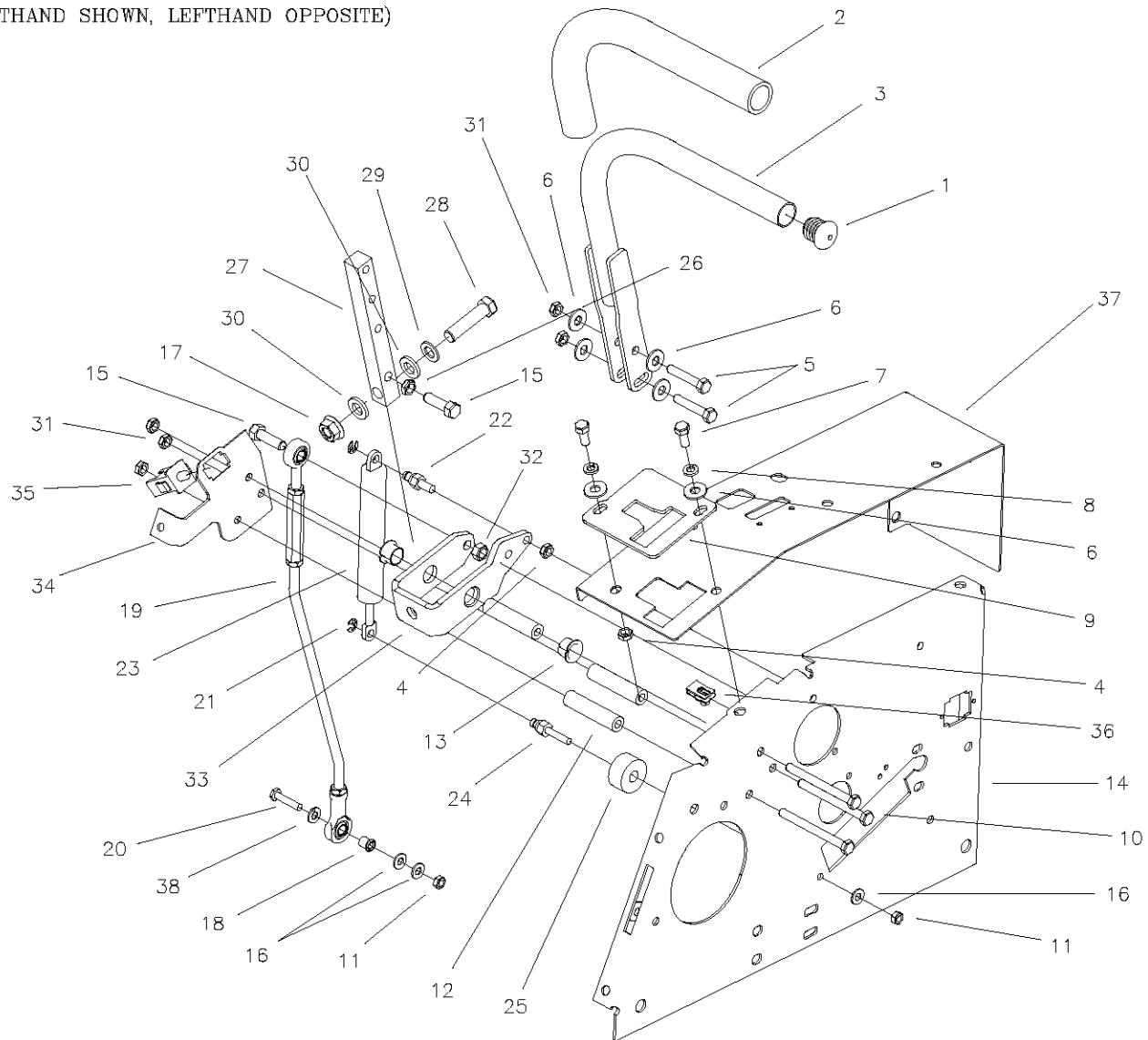

ITEM #	PART #	QTY	DESCRIPTION	ITEM #	PART #	QTY	DESCRIPTION
1	H-2080	2	END PLUG, 15/16" BLACK	21	F-1610	4	E-RING FOR 1/4" SHAFT
2	H-2079	2	FOAM GRIP, 17"	22	638-028P	4	DAMPER BOLT, 5/16-18 X 3/4"
3	659-249W	2	ARM WELDMENT	23	H-2467	2	STEERING DAMPER
4	F-1125	4	5/16 LOCK NUT	24	638-029P	2	DAMPER BOLT 5/16-18 x 3/4"
5	F-1015-18	4	5/16-18 X 1-3/4" HHCS	25	F-2045	2	SPACER
6	F1009-02	12	5/16 FLAT WASHER	26	F-1486	2	3/8-16 JAM NUT
7	F-1015-15	4	5/16-18 x 1" HHCS	27	659-247P	2	LOWER SHIFT BLOCK
8	F-1019-02	4	5/16 LOCK WASHER	28	F-1293	2	1/2-13 x 2" HHCS
9	659-262P	2	NEUTRAL PLATE	29	F-1521	2	1/2" WASHER
10	F-2058	6	5/16-18 X 3-1/2" HHCS	30	606-151P	4	1/2 ID x 1/8 NYLOC WASHER
11	F-1158	4	1/4-20 LOCK NUT	31	F-1005-02	10	5/16-18 NYLOC WASHER
12	659-252P	6	TUBE SPACER	32	F-1005-03	2	3/8-16 LOCK NUT
13	D-3730	4	5/8 FLANGED BUSHING	33	659-243P	2	SHIFTING YOKE
14	659-253W	1	RH SIDE PANEL	34	647-242P	1	RH MOUNTING BRACKET
-	659-255P	1	LH SIDE PANEL	-	647-243P	1	RH MOUNTING BRACKET
15	F-1307	4	3/8-16 x 1-1/2" HHCS	35	E-6474	2	SWITCH, DELTA
16	F-1009-01	6	1/4" FLAT WASHER	36	F-1860	2	5/16-18 "U"-NUT
17	F-2060	2	1/2-13 FLANGED LOCK NUT	37	659-313A	1	RH FENDER CAP-W/DECALS
18	H-2465	2	1/2 x 1/4 SHOULDER WASHER	-	659-257P	1	LH FENDER CAP
19	663-050P	2	STEERING LINKAGE	38	F-1019-01	2	1/4" LOCK WASHER
20	F-1539	4	1/4-20 x 1-1/4" HHCS				

PARKING BRAKE ASSEMBLY & RELATED PARTS FOR JAZEE SR220

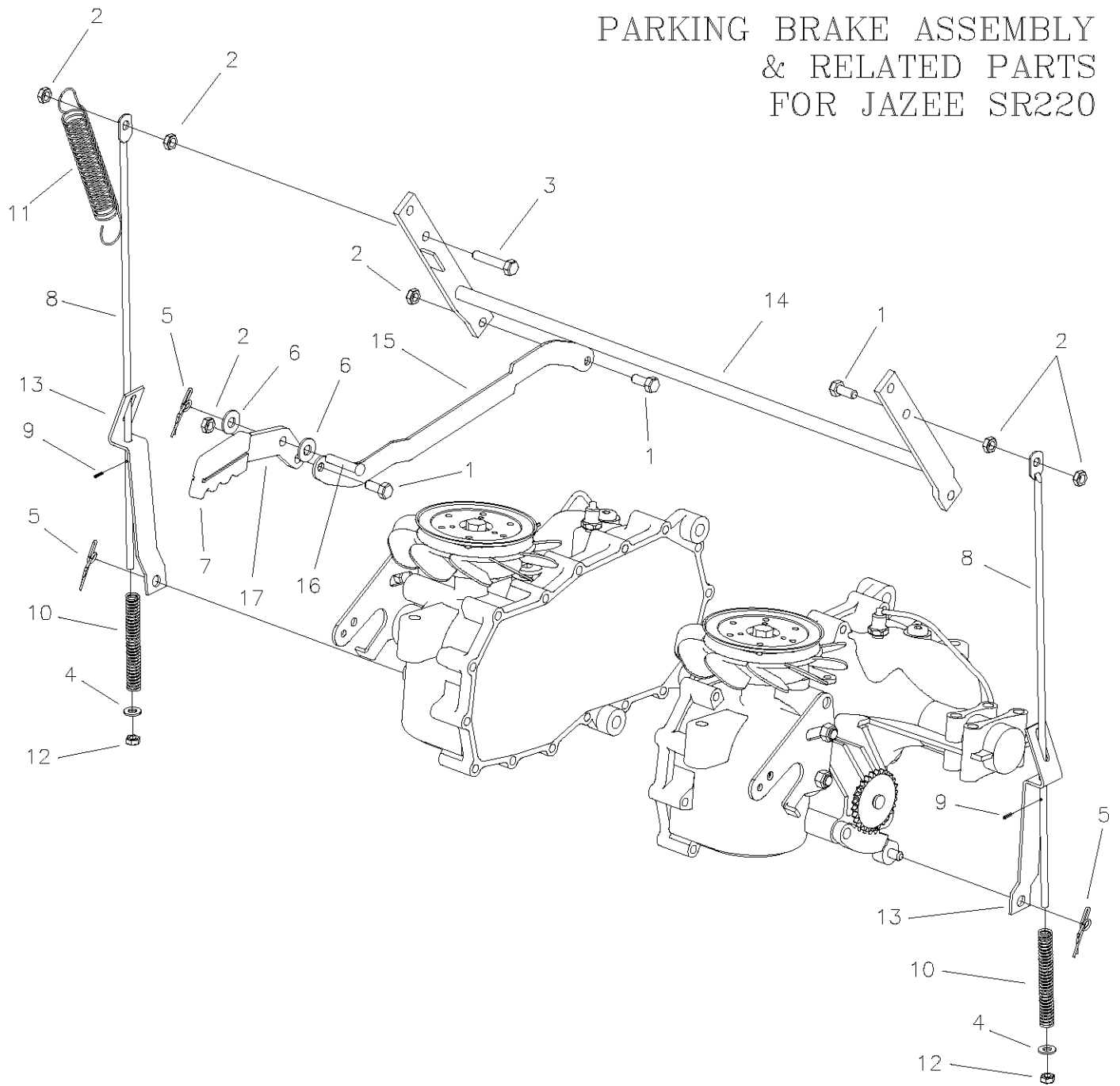

ITEM #	PART #	QTY	DESCRIPTION	ITEM #	PART #	QTY	DESCRIPTION
1	F-1546	3	5/16-18 X 3/4" GR. 5	15	659-203P	1	BRAKE LINK
2	F-1125	6	5/16" STOVER LOCK NUT	16	F-1533	1	5/16 X 1-1/2" CLEVIS PIN
3	F-1015-17	1	5/16-18 X 1-1/2" GR. 5	17	659-308P	1	BRAKE HANDLE
4	F-1009-01	2	1/4" FLAT WASHER				
5	F-1492	3	RUE RING, 5/16-3/8 PIN				
6	F-1009-02	2	5/16" FLAT WASHER				
7	H-1926	1	GRIP, HANDLE, 1/4" X 1"				
8	H-2206	2	BRAKE LINK ROD				
9	H-1800	2	ROLL PIN 3/32 OD X 3/8 LONG				
10	H-2426	2	SPRING, 3.69 X .372 ID X .064				
11	H-1635	1	SPRING, EXT. 3/4 X 4" OAL				
12	F-1748	2	1/4-20 NYLOC NUT				
13	659-013P	2	LOWER BRAKE LINK				
14	659-206W	1	BRAKE ROD WELDMENT				

PARKING BRAKE ASSEMBLY & RELATED PARTS FOR JAZEE PRO SR370

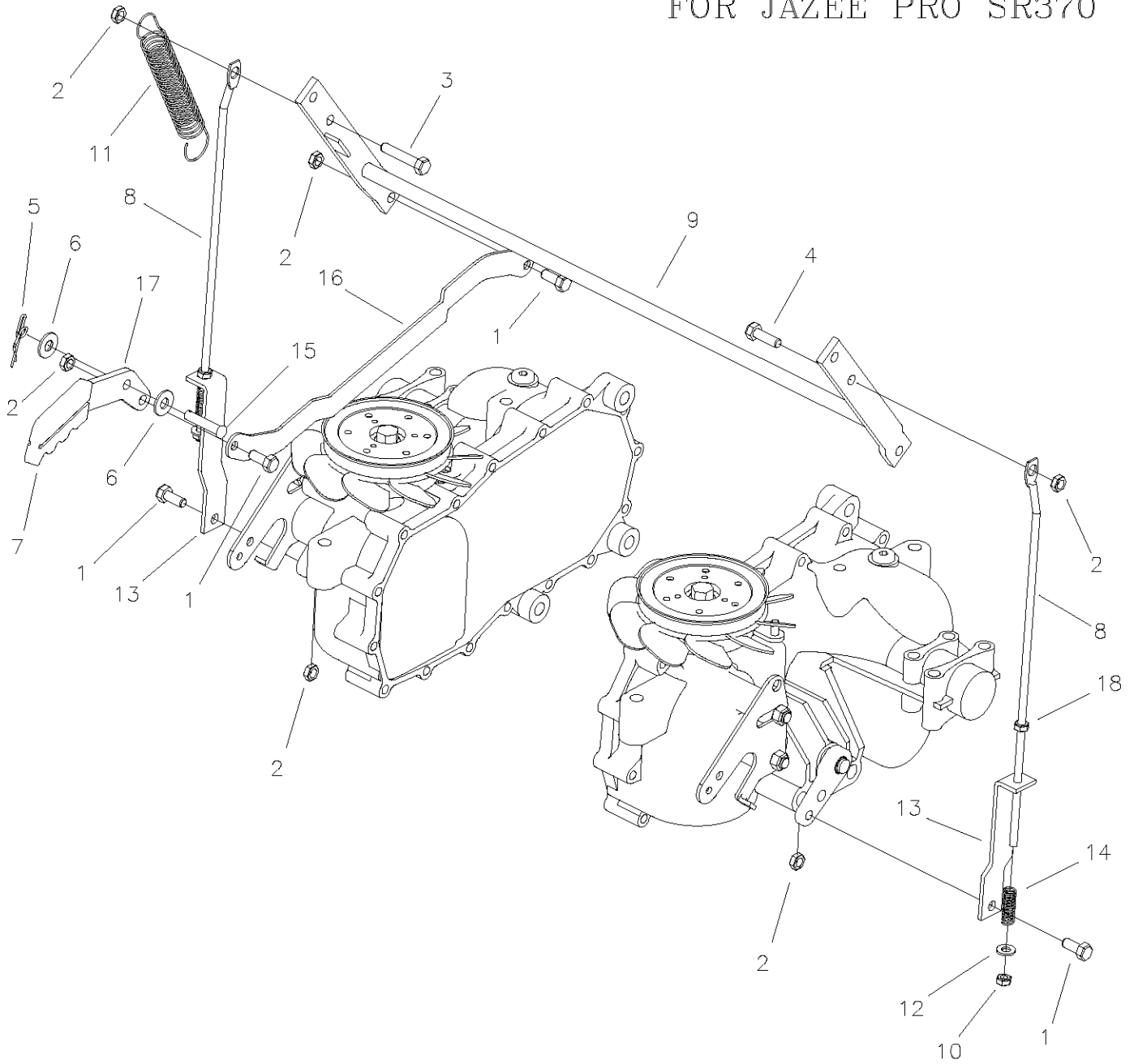

ITEM #	PART #	QTY	DESCRIPTION	ITEM #	PART #	QTY	DESCRIPTION
1	F-1546	4	5/16-18 X 3/4" H.H.C.S.	15	F-1533	1	5/16 x 1-1/2" CLEVIS PIN
2	F-1125	6	5/16" STOVER LOCK NUT	16	659-203P	1	BRAKE LINK
3	F-1015-17	1	5/16-18 X 1-1/2" H.H.C.S.	17	659-308P	1	BRAKE HANDLE
4	F-1015-15	1	5/16-18 X 1" H.H.C.S	18	F-1158	2	1/4" STOVER LOCK NUT
5	F-1492	2	RUE RING, 5/16-3/8 PIN				
6	F-1009-02	2	5/16" FLAT WASHER				
7	H-1926	1	HANDLE GRIP				
8	H-2452	2	BRAKE LINK BAR, BENT				
9	659-206W	1	BRAKE ROD WELDMENT				
10	F-1748	2	1/4" NYLOC LOCK NUT				
11	H-1635	1	EXTENSION SPRING 3/4 X 4"				
12	F-1009-01	2	1/4" FLAT WASHER				
13	659-159P	2	LOWER BRAKE LINK				
14	H-1637	2	COMPRESSION SPRING				

MOTOR & TRANSMISSION ASS'Y
& RELATED PARTS FOR 20HP
KOHLER JAZEE SR220

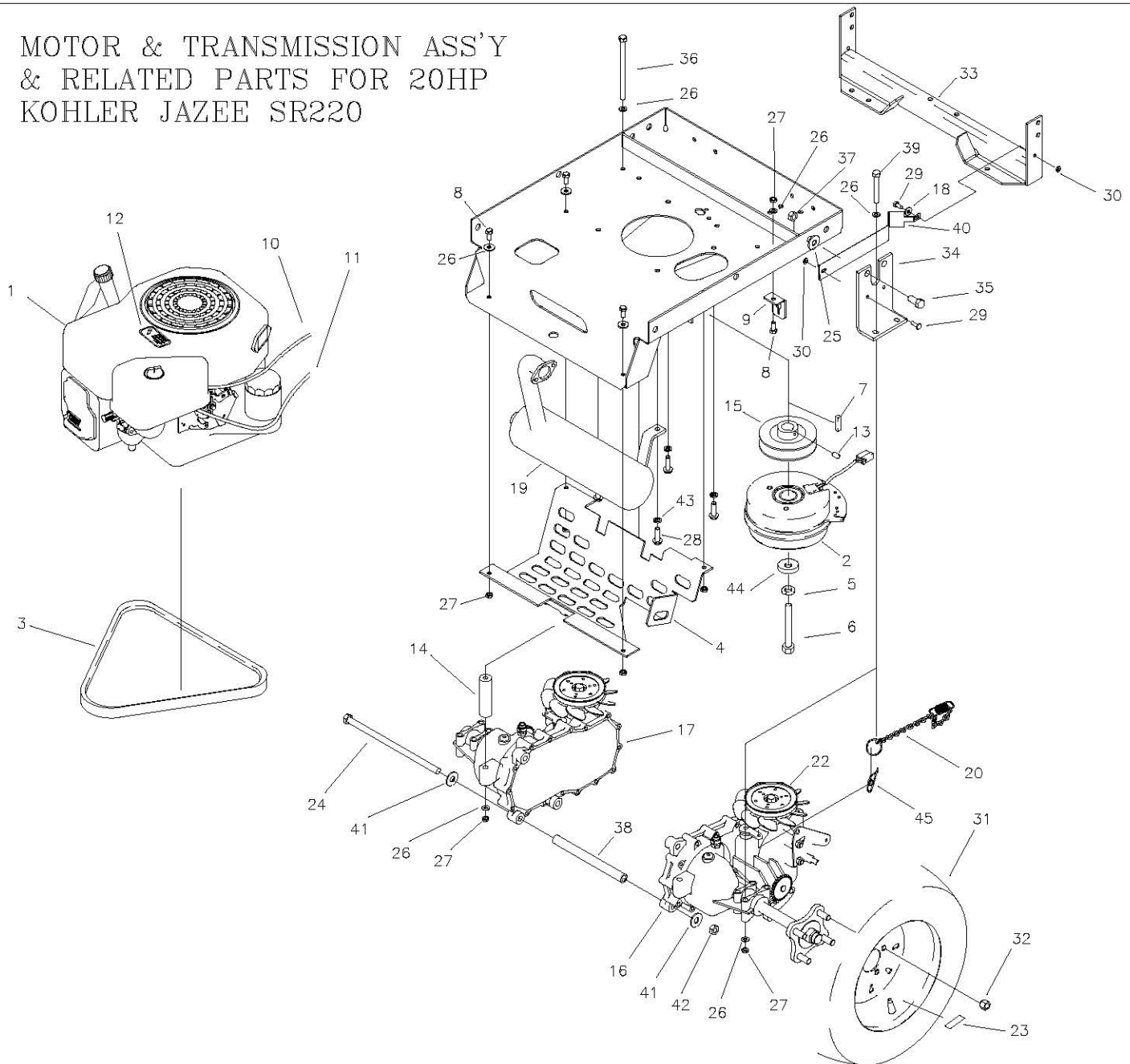

ITEM #	PART #	QTY	DESCRIPTION	ITEM #	PART #	QTY	DESCRIPTION
1	M-5380	1	20 HP. KOHLER ENGINE	24	F-2048	1	3/8-16 X 12" HEX BOLT
2	E-6317	1	CLUTCH-BRAKE FOR 20HP KOHLER	25	F-1009-05	4	1/2" FLAT WASHER
3	D-3524	1	V-BELT-A71 KEVLAR	26	F-1009-02	14	5/16" FLAT WASHER
4	700-059P	1	MUFFLER HEAT SHIELD	27	F-1125	12	5/16-18 LOCK NUT
5	F-1019-04	1	7/16 LOCK WASHER	28	F-2085	4	3/8-16 x 1-1/4" SELF TAPPING
6	F-1545	1	7/16-20 X 3" 20HP KOHLER	29	F-1015-02	8	1/4-20 X 5/8" GR. 5
7	621-113P	1	KEY, 1/4 SQ. X 1-1/4"	30	F-1158	8	1/4-20 LOCK NUTS
8	F-1546	2	5/16-18 X 3/4" BOLT	31	D-3729	2	TIRE, 18 X 8.5-8
9	700-026P	1	FREE WHEEL ANCHOR 20HP KOHLER	32	F-1499	8	LUG NUT, 1/2 X 20
10	H-2403	1	CHOKE CABLE, 20HP KOHLER	33	659-296W	1	BRACE WELDMENT
11	H-2609	1	THROTTLE CABLE 20HP KOHLER	34	659-116P	2	HYDRO MOUNT BRACE
12	P-10077-11	1	DECAL, "CLEAN"	35	F-1386	2	1/2-13 X 1-1/4" BOLT
13	F-1228	1	SETSCREW, 1/4" X 1/4"	36	F-1652	2	5/16-18 X 6" BOLT
14	659-121P	2	REAR HYDRO BRACE	37	F-1005-05	2	1/2" STOVER LOCK NUT
15	D-3726	1	MOTOR PULLEY 20HP KOHLER	38	659-120P	1	HYDRO BRACE
16	D-3783-01	1	TRANSAXLE HYDRO (RH)	39	F-1544	4	5/16-18 X 3" BOLT
17	D-3783-02	1	TRANSAXLE HYDRO (LH)	40	659-156P	2	FAN SHROUD
18	F-1009-01	4	1/4" FLAT WASHER	41	F-1009-03	4	3/8" FLAT WASHER
19	H-2694	1	MUFFLER FOR 20HP KOHLER	42	F-1005-03	1	3/8-16 LOCK NUT
20	661-066P	2	FREEWHEEL CHAIN W/SPRING	43	F-1019-03	4	3/8" LOCK WASHER
21	700-024W	1	MOTOR MOUNT 20HP KOHLER	44	606-347P	1	15/32" I.D. WASHER
22	H-2539	2	FAN BLADE REPLACEMENT	45	F-1492	2	5/16-3/8 RUE RING
23	P-11384	2	DECAL, TIRE PRESSURE, 12 PSI				

MOTOR & TRANSMISSION ASS'Y
& RELATED PARTS FOR 24HP
KOHLER JAZEE SR220

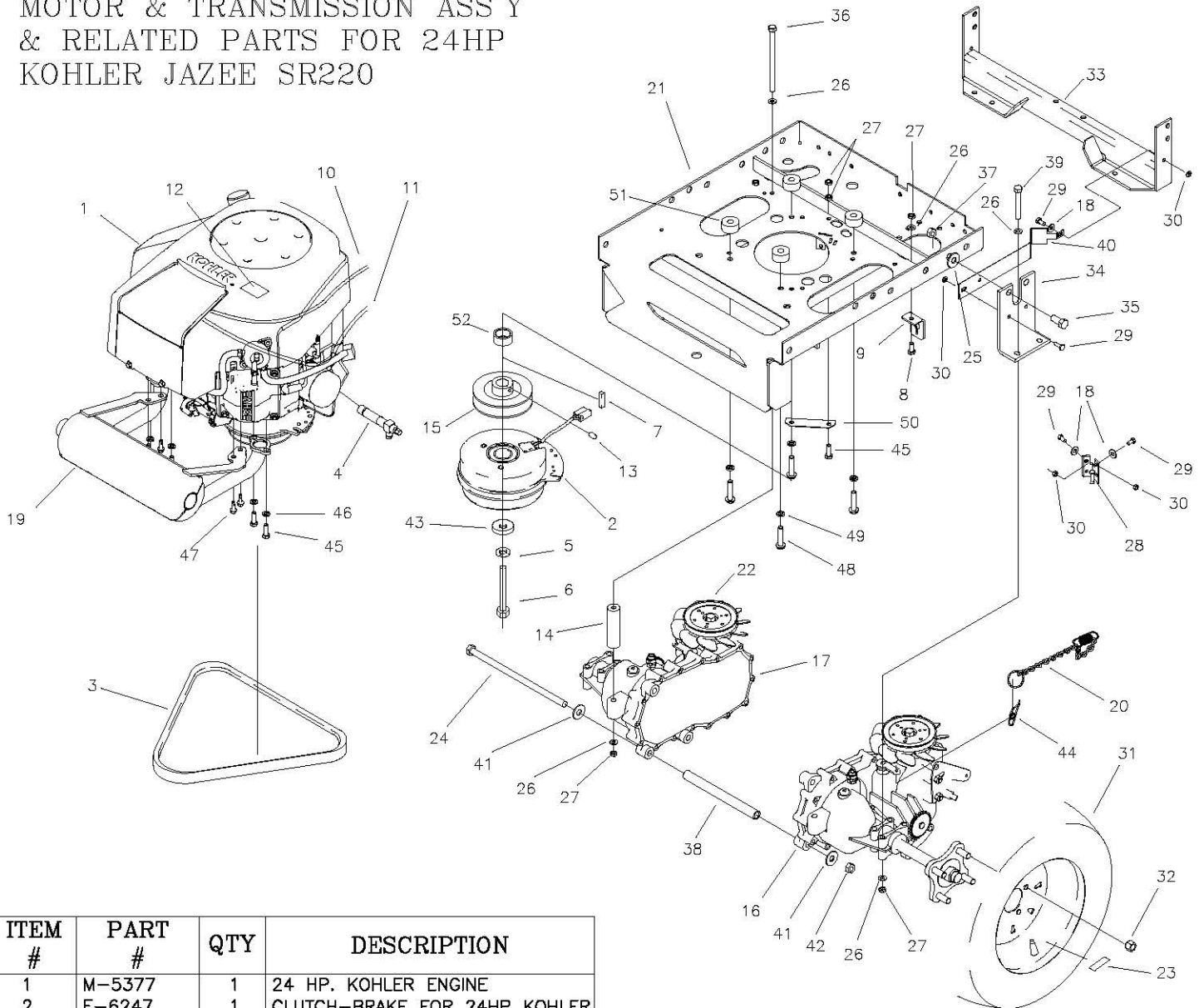

ITEM #	PART #	QTY	DESCRIPTION
1	M-5377	1	24 HP. KOHLER ENGINE
2	E-6247	1	CLUTCH-BRAKE FOR 24HP KOHLER
3	D-3524	1	V-BELT-A71 KEVLAR
4	H-2589	1	OIL DRAIN VALVE
5	F-1019-04	1	7/16 LOCK WASHER
6	F-1904	1	7/16-20 X 2-1/2" 24HP KOHLER
7	621-113P	1	KEY, 1/4 SQ. X 1-1/4"
8	F-1546	2	5/16-18 X 3/4" BOLT
9	659-119P	1	FREE WHEEL ANCHOR 24HP KOHLER
10	H-2404	1	CHOKE CABLE, 24HP KOHLER
11	H-2610	1	THROTTLE CABLE 24HP KOHLER
12	P-10077-11	1	DECAL, "CLEAN"
13	F-1228	1	SETSCREW, 1/4" X 1/4"
14	659-121P	2	REAR HYDRO BRACE
15	647-036P	1	MOTOR PULLEY 24HP KOHLER
16	D-3783-01	1	TRANSAXLE HYDRO (RH)
17	D-3783-02	1	TRANSAXLE HYDRO (LH)
18	F-1009-01	4	1/4" FLAT WASHER
19	H-2513	1	MUFFLER FOR 24HP KOHLER
20	659-066P	2	FREEWHEEL CHAIN W/SPRING
21	659-174W	1	MOTOR MOUNT 24HP KOHLER
22	H-2539	2	FAN BLADE REPLACEMENT
23	P-11384	2	DECAL, TIRE PRESSURE, 12 PSI
24	F-2048	1	3/8-16 X 12" HEX BOLT
25	F-1009-05	4	1/2" FLAT WASHER
26	F-1009-02	14	5/16" FLAT WASHER
27	F-1125	10	5/16-18 LOCK NUT
28	659-015W	1	CLUTCH STOP WELDMENT
29	F-1015-02	8	1/4-20 X 5/8" GR. 5
30	F-1158	8	1/4-20 LOCK NUTS

ITEM #	PART #	QTY	DESCRIPTION
31	D-3729	2	TIRE, 18 X 8.5-8
32	F-1499	8	LUG NUT, 1/2 X 20
33	659-296W	1	BRACE WELDMENT
34	659-116P	2	HYDRO MOUNT BRACE
35	F-1386	2	1/2-13 X 1-1/4" BOLT
36	F-1652	2	5/16-18 X 6" BOLT
37	F-1005-05	2	1/2" STOVER LOCK NUT
38	659-120P	1	HYDRO BRACE
39	F-1544	4	5/16-18 X 3" BOLT
40	659-156P	2	FAN SHROUD
41	F-1009-03	4	3/8" FLAT WASHER
42	F-1005-03	1	3/8-16 LOCK NUT
43	606-347P	1	15/32" I.D. WASHER
44	F-1492	2	5/16-3/8 RUE RING
45	F-1015-15	3	5/16-18 x 1" CAPSCREW
46	F-1019-12	2	5/16" LOCK WASHER
47	F-2049	2	M-6 x 1.0 x 20 H.F. FORM SCREW
48	F-2055	4	3/8-16 x 1-3/4" CAPSCREW
49	F-1019-03	4	3/8" LOCK WASHER
50	647-085P	1	GROUND STRAP
51	F-2045	4	SPACER
52	F-2043	1	SPACER

MOTOR & TRANSMISSION ASS'Y
& RELATED PARTS FOR 22HP
KAWASAKI JAZEE PRO SR370

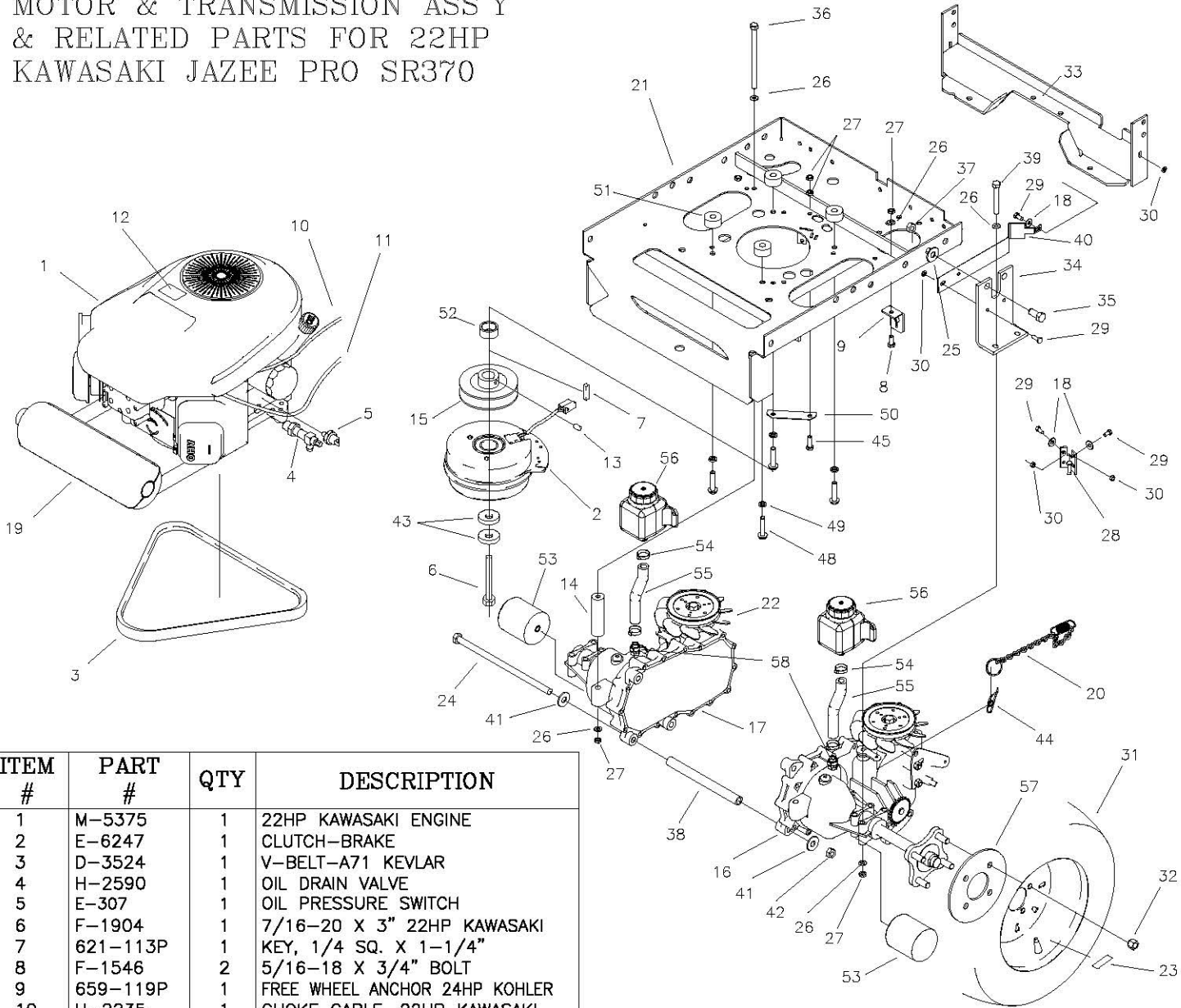

ITEM #	PART #	QTY	DESCRIPTION
1	M-5375	1	22HP KAWASAKI ENGINE
2	E-6247	1	CLUTCH-BRAKE
3	D-3524	1	V-BELT-A71 KEVLAR
4	H-2590	1	OIL DRAIN VALVE
5	E-307	1	OIL PRESSURE SWITCH
6	F-1904	1	7/16-20 X 3" 22HP KAWASAKI
7	621-113P	1	KEY, 1/4 SQ. X 1-1/4"
8	F-1546	2	5/16-18 X 3/4" BOLT
9	659-119P	1	FREE WHEEL ANCHOR 24HP KOHLER
10	H-2235	1	CHOKE CABLE, 22HP KAWASAKI
11	H-2610	1	THROTTLE CABLE
12	P-10077-11	1	DECAL, "CLEAN"
13	F-1228	1	SETSCREW, 1/4" X 1/4"
14	659-121P	2	REAR HYDRO BRACE
15	659-154P	1	MOTOR PULLEY
16	D-3788-01	1	TRANSAXLE ZT-3100 (RH)
17	D-3788-02	1	TRANSAXLE ZT-3100 (LH)
18	F-1009-01	4	1/4" FLAT WASHER
19	H-2607	1	MUFFLER FOR 22HP KAWASAKI
20	659-066P	2	FREEWHEEL CHAIN W/SPRING
21	659-174W	1	MOTOR MOUNT 24HP KOHLER
22	H-2539	2	FAN BLADE REPLACEMENT
23	P-11384	2	DECAL, TIRE PRESSURE, 12 PSI
24	F-2007	1	3/8-16 X 12-1/2" HEX BOLT
25	F-1009-05	4	1/2" FLAT WASHER
26	F-1009-02	14	5/16" FLAT WASHER
27	F-1125	10	5/16-18 LOCK NUT
28	659-015W	1	CLUTCH STOP WELDMENT
29	F-1015-02	8	1/4-20 X 5/8" GR. 5
30	F-1158	8	1/4-20 LOCK NUTS
31	D-3353	2	TIRE, 20"-10x10 (W/48" DECKS)
-	D-3787	2	TIRE, 20"-12x10 (W/52"&60" DECKS)
32	F-1499	8	LUG NUT, 1/2 X 20
33	659-296W	1	BRACE WELDMENT
34	659-116P	2	HYDRO MOUNT BRACE
35	F-1386	2	1/2-13 X 1-1/4" BOLT
36	F-1652	2	5/16-18 X 6" BOLT

ITEM #	PART #	QTY	DESCRIPTION
37	F-1005-05	2	1/2" STOVER LOCK NUT
38	659-173P	1	HYDRO BRACE
39	F-1544	4	5/16-18 X 3" BOLT
40	659-156P	2	FAN SHROUD
41	F-1009-03	4	3/8" FLAT WASHER
42	F-1005-03	1	3/8-16 LOCK NUT
43	606-347P	2	15/32" I.D. WASHER
44	F-1492	2	5/16-3/8 RUE RING
45	F-1015-15	3	5/16-18 x 1" CAPSCREW
46	F-1019-12	2	5/16" LOCK WASHER
47	F-2049	2	M-6 x 1.0 x 20 H.F. FORM SCREW
48	F-2055	4	3/8-16 x 1-3/4" CAPSCREW
49	F-1019-03	4	3/8" LOCK WASHER
50	647-085P	1	GROUND STRAP
51	F-2045	4	SPACER
52	F-2043	1	SPACER
53	H-2567	2	TRANSAXLE OIL FILTER
54	H-2535	4	HOSE CLAMP
55	H-2549	2	HOSE 5" LONG
56	D-3791	2	SMALL HYDRO TANK
57	659-092P	2	WHEEL BACKING PLATE
58	H-2517	2	VENT TUBE ADAPTER

MOTOR & TRANSMISSION ASS'Y
& RELATED PARTS FOR 27HP
KOHLER JAZEE PRO SR370

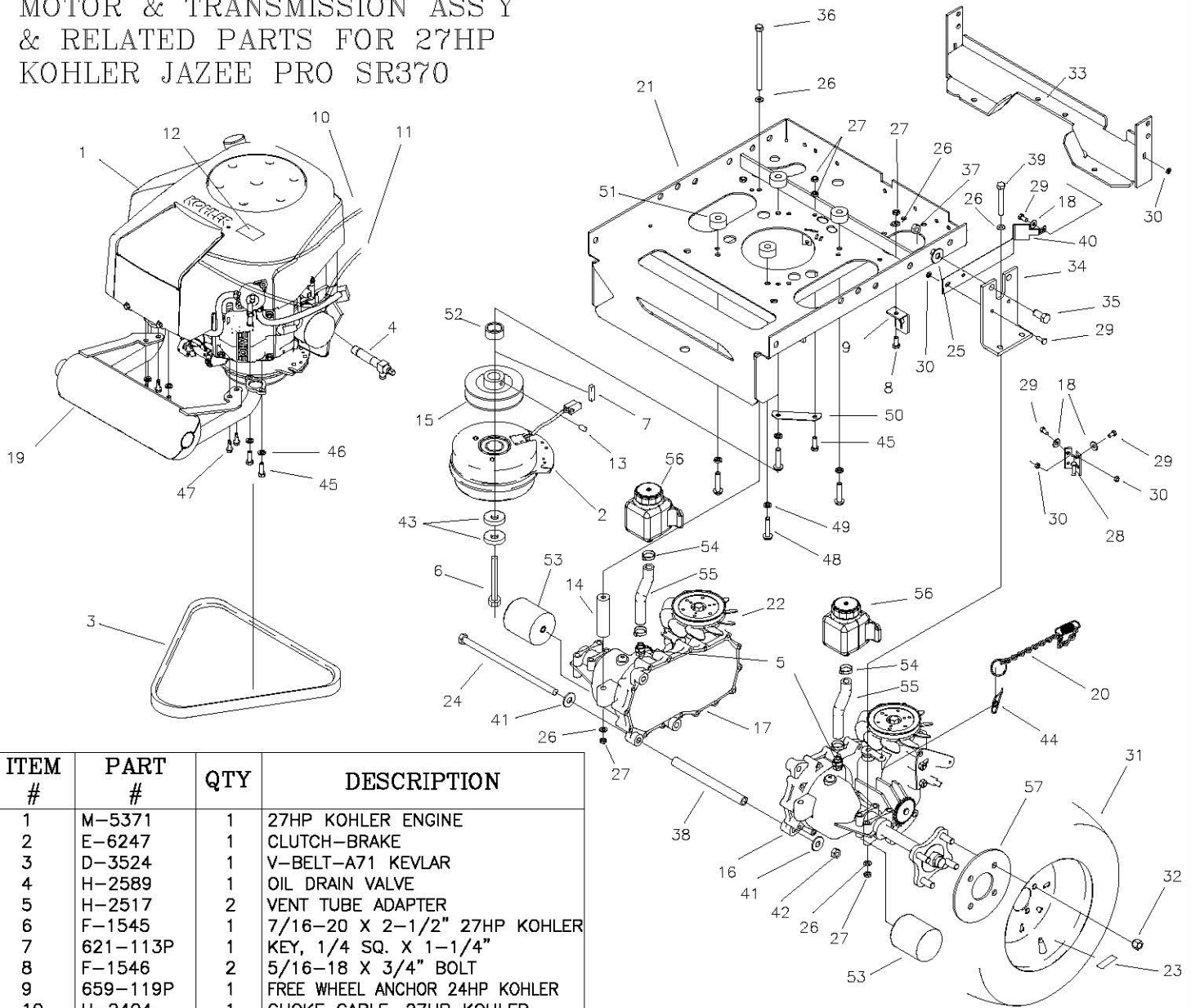

ITEM #	PART #	QTY	DESCRIPTION
1	M-5371	1	27HP KOHLER ENGINE
2	E-6247	1	CLUTCH-BRAKE
3	D-3524	1	V-BELT-A71 KEVLAR
4	H-2589	1	OIL DRAIN VALVE
5	H-2517	2	VENT TUBE ADAPTER
6	F-1545	1	7/16-20 X 2-1/2" 27HP KOHLER
7	621-113P	1	KEY, 1/4 SQ. X 1-1/4"
8	F-1546	2	5/16-18 X 3/4" BOLT
9	659-119P	1	FREE WHEEL ANCHOR 24HP KOHLER
10	H-2404	1	CHOKE CABLE, 27HP KOHLER
11	H-2610	1	THROTTLE CABLE
12	P-10077-11	1	DECAL, "CLEAN"
13	F-1228	1	SETSCREW, 1/4" X 1/4"
14	659-121P	2	REAR HYDRO BRACE
15	647-154P	1	MOTOR PULLEY
16	D-3788-01	1	TRANSAXLE ZT-3100 (RH)
17	D-3788-02	1	TRANSAXLE ZT-3100 (LH)
18	F-1009-01	4	1/4" FLAT WASHER
19	H-2513	1	MUFFLER FOR 24HP KOHLER
20	659-066P	2	FREEWHEEL CHAIN W/SPRING
21	659-174W	1	MOTOR MOUNT 24HP KOHLER
22	H-2539	2	FAN BLADE REPLACEMENT
23	P-11384	2	DECAL, TIRE PRESSURE, 12 PSI
24	F-2007	1	3/8-16 X 12-1/2" HEX BOLT
25	F-1009-05	4	1/2" FLAT WASHER
26	F-1009-02	14	5/16" FLAT WASHER
27	F-1125	10	5/16-18 LOCK NUT
28	659-015W	1	CLUTCH STOP WELDMENT
29	F-1015-02	8	1/4-20 X 5/8" GR. 5
30	F-1158	8	1/4-20 LOCK NUTS
31	D-3353	2	TIRE, 20"-10x10 (W/48" DECKS)
-	D-3787	2	TIRE, 20"-12x10 (W/52"&60" DECKS)
32	F-1499	8	LUG NUT, 1/2 X 20
33	659-296W	1	BRACE WELDMENT
34	659-116P	2	HYDRO MOUNT BRACE
35	F-1386	2	1/2-13 X 1-1/4" BOLT
36	F-1652	2	5/16-18 X 6" BOLT

ITEM #	PART #	QTY	DESCRIPTION
37	F-1005-05	2	1/2" STOVER LOCK NUT
38	659-173P	1	HYDRO BRACE
39	F-1544	4	5/16-18 X 3" BOLT
40	659-156P	2	FAN SHROUD
41	F-1009-03	4	3/8" FLAT WASHER
42	F-1005-03	1	3/8-16 LOCK NUT
43	606-347P	2	15/32" I.D. WASHER
44	F-1492	2	5/16-3/8 RUE RING
45	F-1015-15	3	5/16-18 x 1" CAPSCREW
46	F-1019-12	2	5/16" LOCK WASHER
47	F-2049	2	M-6 x 1.0 x 20 H.F. FORM SCREW
48	F-2055	4	3/8-16 x 1-3/4" CAPSCREW
49	F-1019-03	4	3/8" LOCK WASHER
50	647-085P	1	GROUND STRAP
51	F-2045	4	SPACER
52	F-2043	2	SPACER
53	H-2567	2	TRANSAXLE OIL FILTER
54	H-2535	4	HOSE CLAMP
55	H-2549	2	HOSE 5" LONG
56	D-3791	2	SMALL HYDRO TANK
57	659-092P	2	WHEEL BACKING PLATE

E-6405 WIRE HARNESS & RELATED PARTS FOR 20HP, 24HP, & 27HP KOHLER - JOYSTICK

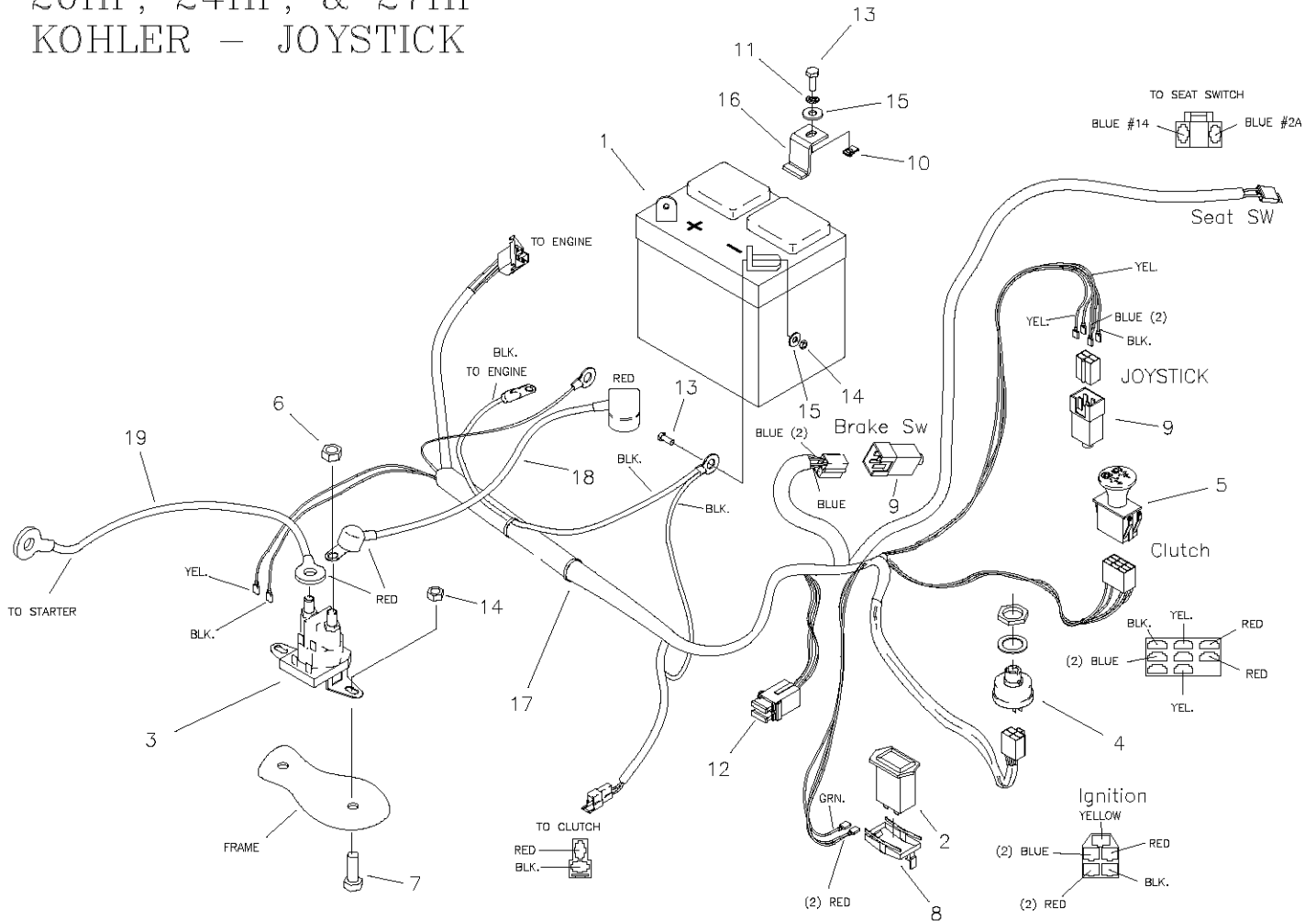

ITEM #	PART #	QTY	DESCRIPTION
1	E-5812	1	BATTERY (20HP KOHLER)
-	E-6271	1	BATTERY (24HP & 27HP KOHLER)
2	E-5878	1	HOUR METER
3	E-6054	1	SOLENOID
4	E-5873	1	START SWITCH
5	E-6403	1	CLUTCH SWITCH
6	F-1011-01	2	1/4-20 NUT
7	F-1015-02	2	1/4-20 x 5/8" CAPSCREW
8	E-6369	1	RETAINER CLIP
9	E-6297	2	BRAKE SWITCH
10	F-1858	1	1/4-20 U-NUT
11	F-1019-01	1	1/4" LOCK WASHER
12	E-6207	2	FUSE, #ATC-30
13	F-1538	3	1/4-20 x 3/4" CAPSCREW
14	F-1158	5	1/4-20 STOVER NUT
15	F-1009-01	5	1/4" FLAT WASHER
16	659-137P	1	BATTERY HOLD DOWN
17	E-6405	1	WIRE HARNESS
18	E-6418	1	CABLE, BATTERY TO SOLENOID
19	E-6419	1	CABLE, SOLENOID TO ENGINE
-NOT SHOWN-			
	E-6374	1	SEAT SWITCH
	E-6281	1	KEY SWITCH

E-6415 WIRE HARNESS & RELATED PARTS FOR 22HP KAWASAKI - JOYSTICK

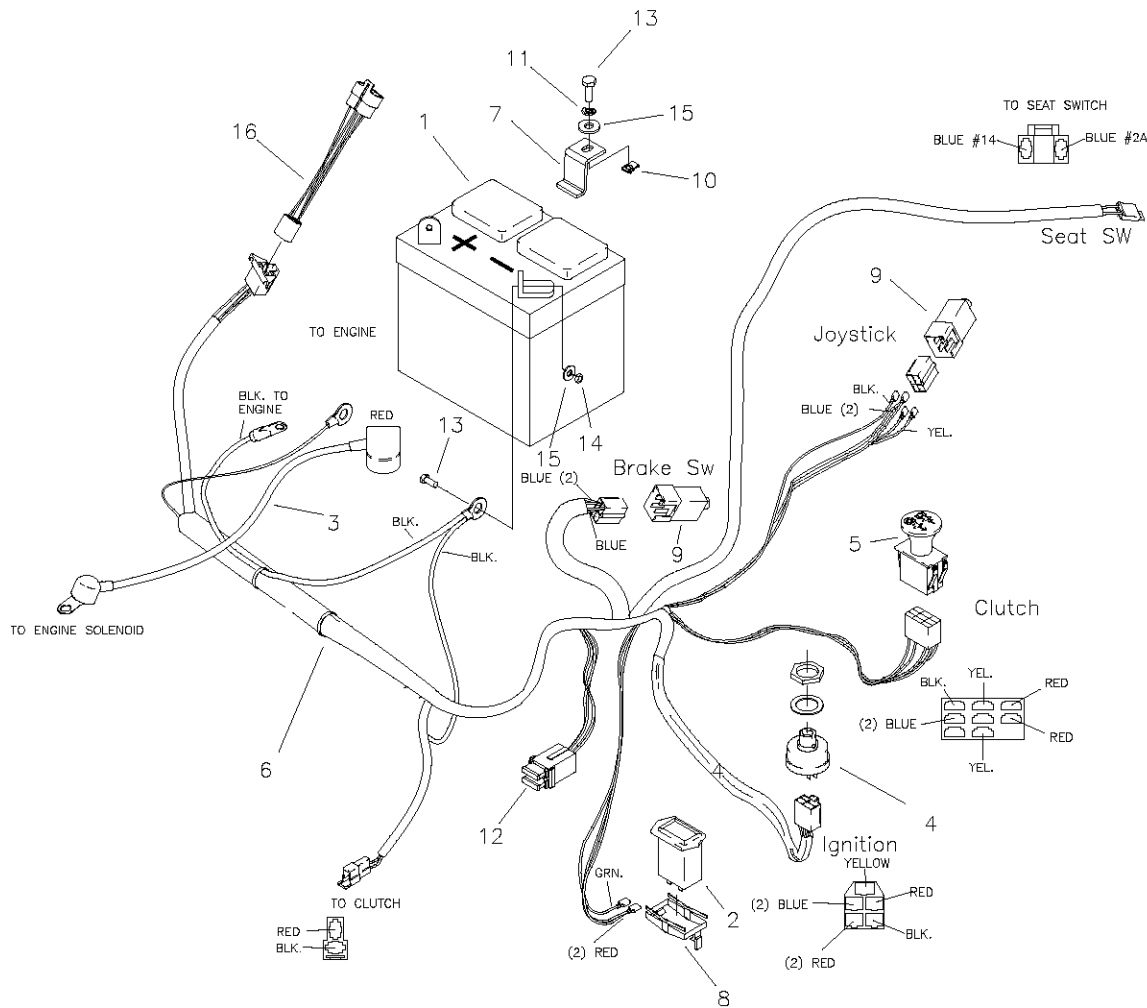

ITEM #	PART #	QTY	DESCRIPTION
1	E-6271	1	BATTERY
2	E-5878	1	HOUR METER
3	E-6418	1	CABLE, BATTERY TO SOLENOID
4	E-5873	1	START SWITCH
5	E-6403	1	CLUTCH SWITCH
6	E-6415	1	WIRE HARNESS
7	659-137P	1	BATTERY HOLD DOWN
8	E-6369	1	RETAINER CLIP
9	E-6297	2	BRAKE SWITCH
10	F-1858	1	1/4-20 U-NUT
11	F-1019-01	1	1/4" LOCK WASHER
12	E-6207	2	FUSE, #ATC-30
13	F-1538	3	1/4-20 x 3/4" CAPSCREW
14	F-1158	5	1/4-20 STOVER NUT
15	F-1009-01	5	1/4" FLAT WASHER
16	E-6417	1	WIRE HARNESS ADAPTER
-NOT SHOWN-			
	E-6374	1	SEAT SWITCH
	E-6281	1	KEY SWITCH

E-6416 WIRE HARNESS
& RELATED PARTS FOR
20HP, 24HP, 27HP KOHLER
& 22HP KAWASAKI - TWINSTICK

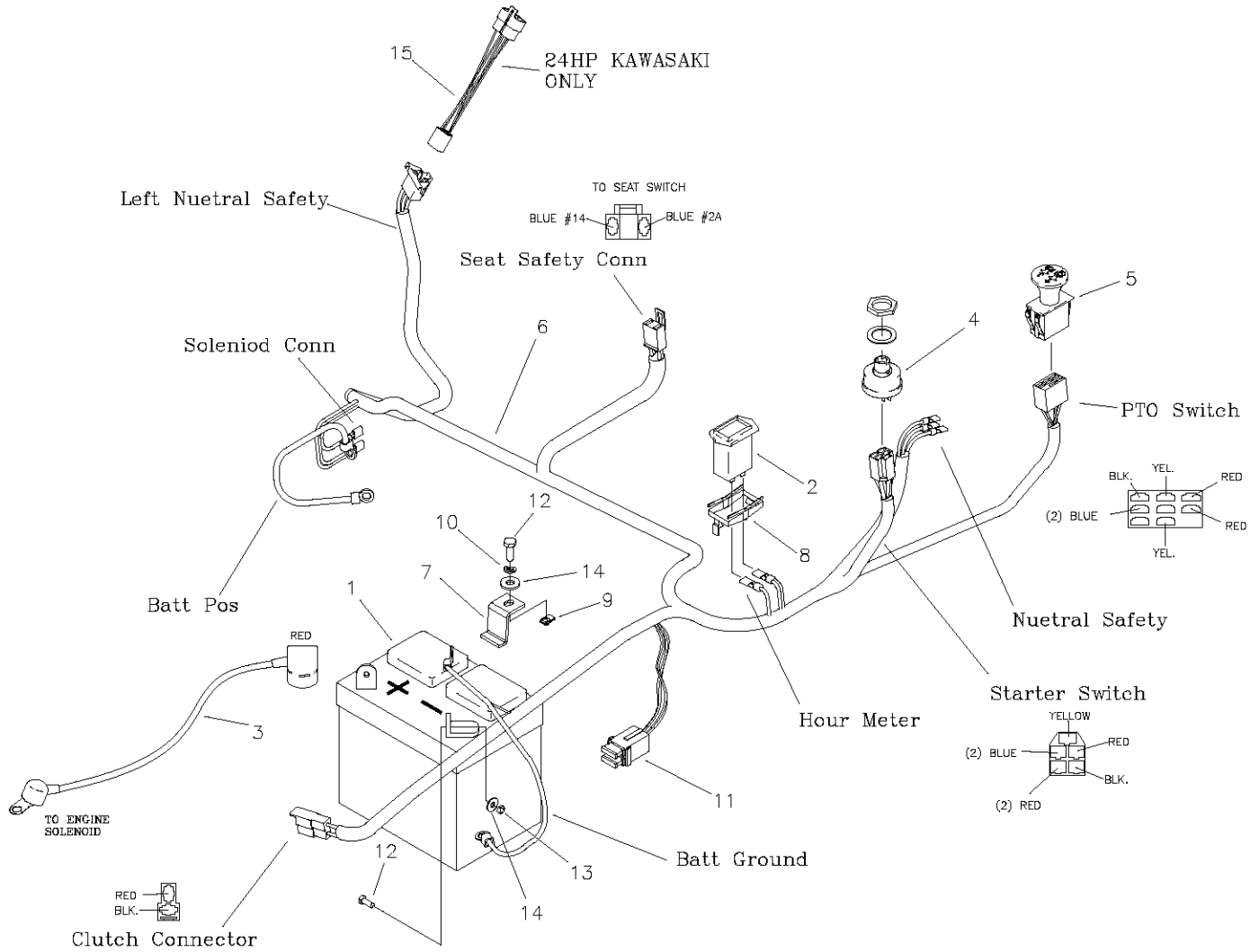

ITEM #	PART #	QTY	DESCRIPTION
1	E-5812	1	BATTERY (20HP KOHLER)
-	E-6271	1	BATTERY (24HP & 27HP KOHLER)
2	E-5878	1	HOUR METER
3	E-6418	1	CABLE, BATTERY TO SOLENOID
4	E-5873	1	START SWITCH
5	E-6403	1	CLUTCH SWITCH
6	E-6416	1	WIRE HARNESS
7	659-137P	1	BATTERY HOLD DOWN
8	E-6369	1	RETAINER CLIP
9	F-1858	1	1/4-20 U-NUT
10	F-1019-01	1	1/4" LOCK WASHER
11	E-6207	2	FUSE, #ATC-30
12	F-1538	3	1/4-20 x 3/4" CAPSCREW
13	F-1158	2	1/4-20 STOVER NUT
14	F-1009-01	3	1/4" FLAT WASHER
15	E-6417	1	KAWASAKI HARNESS ADAPTER
-NOT SHOWN-			
	E-6374	1	SEAT SWITCH
	E-6281	1	KEY SWITCH

E-6417 WIRE HARNESS ADAPTER
 & RELATED PARTS FOR
 & 22HP KAWASAKI

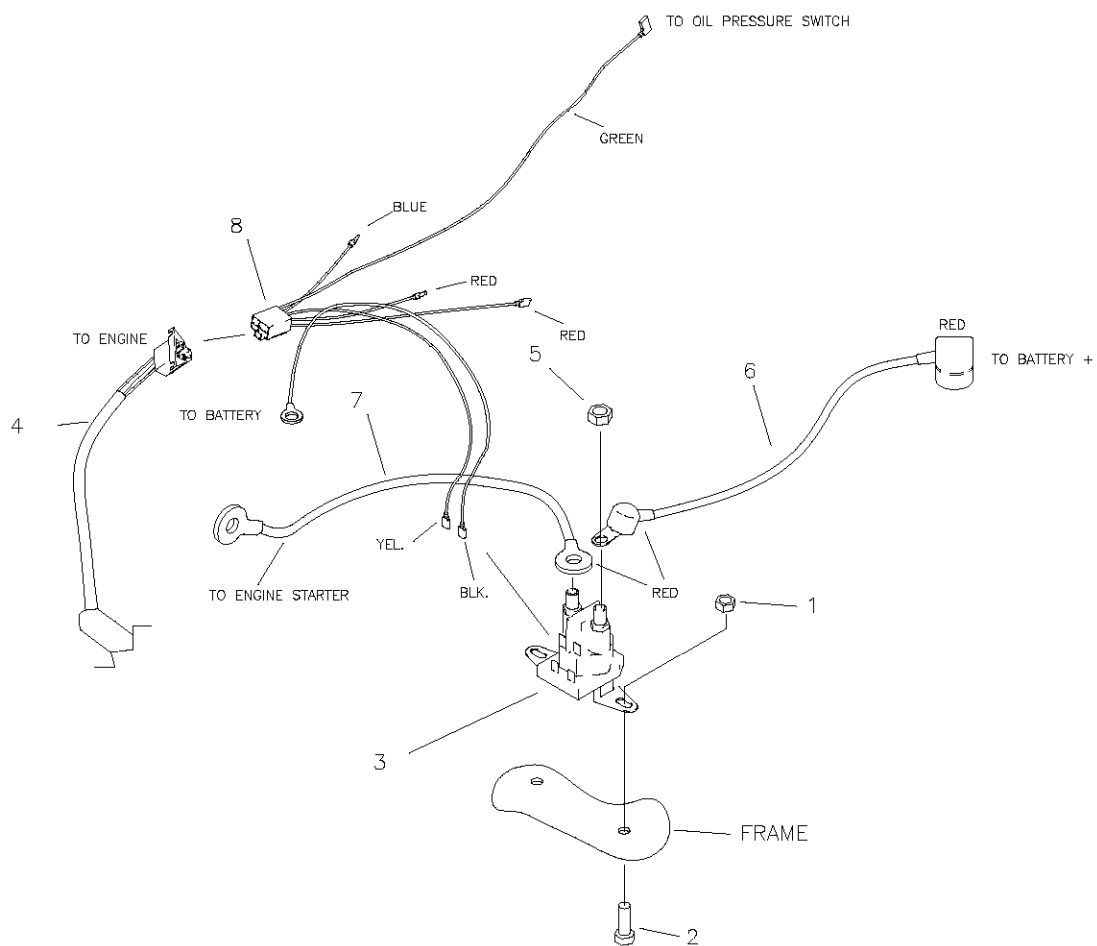

ITEM #	PART #	QTY	DESCRIPTION
1	F-1158	2	1/4-20 STOVER NUT
2	F-1015-02	2	1/4-20 x 5/8" CAPSCREW
3	E-6054	1	SOLENOID
4	E-6415	1	WIRE HARNESS (JOYSTICK)
-	E-6416	1	WIRE HARNESS (TWINSTICK)
-	E-6271	1	BATTERY (24HP & 27HP KOHLER)
5	F-1011-01	2	1/4-20 NUT
6	E-6418	1	CABLE, BATTERY TO SOLENOID
7	E-6419	1	CABLE, SOLENOID TO ENGINE
8	E-6417	1	KAWASAKI HARNESS ADAPTER

E-6436 WIRE HARNESS ADAPTER
 & RELATED PARTS FOR 20HP, 24HP
 & 27HP KOHLER (TWINSTICK)

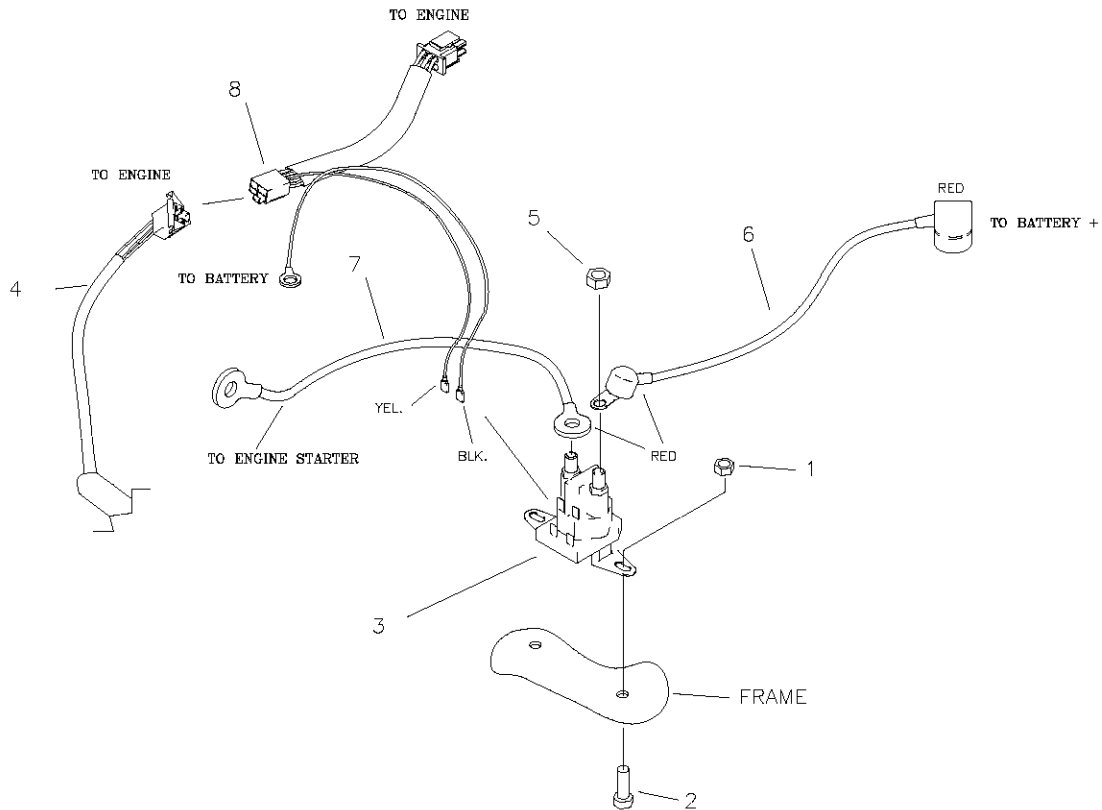

ITEM #	PART #	QTY	DESCRIPTION
1	F-1158	2	1/4-20 STOVER NUT
2	F-1015-02	2	1/4-20 x 5/8" CAPSCREW
3	E-6054	1	SOLENOID
4	E-6416	1	WIRE HARNESS (TWINSTICK)
5	F-1011-01	2	1/4-20 NUT
6	E-6418	1	CABLE, BATTERY TO SOLENOID
7	E-6419	1	CABLE, SOLENOID TO ENGINE
8	E-6436	1	ENGINE ADAPTER