

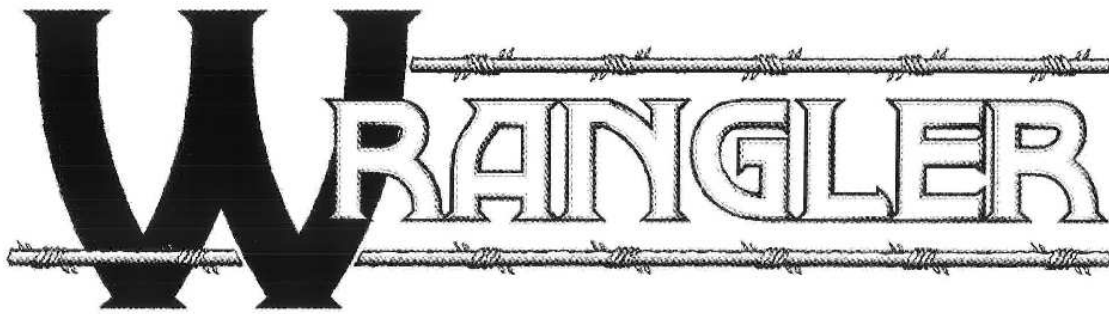

Repair Parts Manual For:



**SR-125**

*Zero Turn Radius Mower*

COUNTRY CLIPPER  
**WRANGLER - SR125**  
ZERO TURN RADIUS MOWER

TABLE OF CONTENTS

MOWER DECK.....	PAGE 2 & 3
SPINDLE ASSEMBLY.....	PAGE 4
RUBBER CHUTE ASSEMBLY.....	PAGE 5
DECK LIFT ASSEMBLY.....	PAGE 6
FRONT END ASSEMBLY.....	PAGE 7
FRAME AND SIDE ASSEMBLY.....	PAGE 8
SEAT AND RELATED PARTS.....	PAGE 9
JOYSTICK ASSEMBLY.....	PAGE 10
JOYSTICK STEERING ASSEMBLY.....	PAGE 11
BRAKE ASSEMBLY.....	PAGE 12
FUEL TANK ASSEMBLY.....	PAGE 13
UNDERSIDE OF MOTOR MOUNT.....	PAGE 14
MOTOR AND MOUNT ASSEMBLY.....	PAGE 15
MOTOR AND TRANSAXLE.....	PAGE 16
REAR WHEEL AND SIDE PANEL.....	PAGE 17
WIRE HARNESS & BATTERY.....	PAGE 18

# MOWER DECK

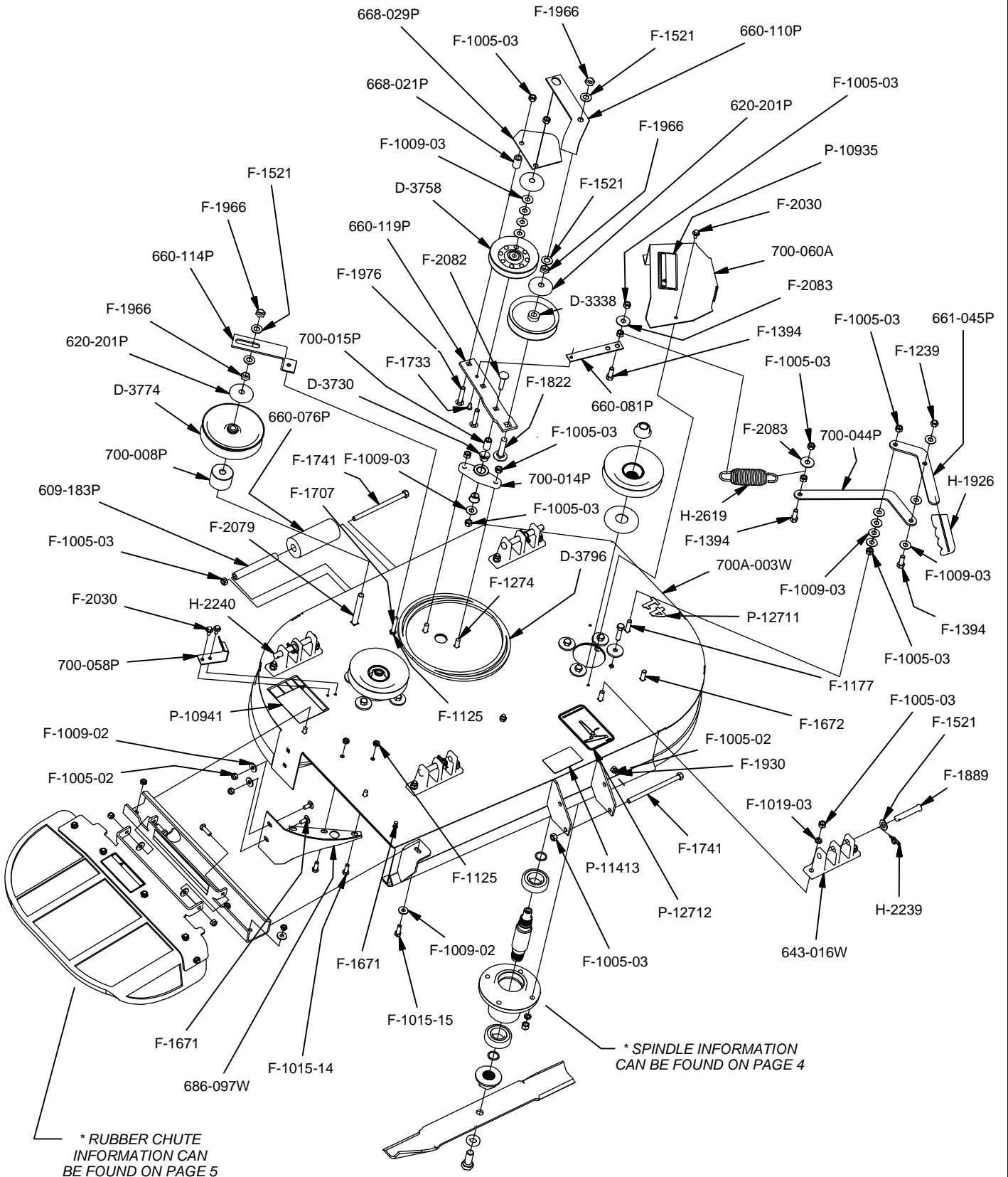

\* RUBBER CHUTE INFORMATION CAN BE FOUND ON PAGE 5

\* SPINDLE INFORMATION CAN BE FOUND ON PAGE 4

\* PART DESCRIPTIONS ARE ON THE NEXT PAGE.

# MOWER DECK

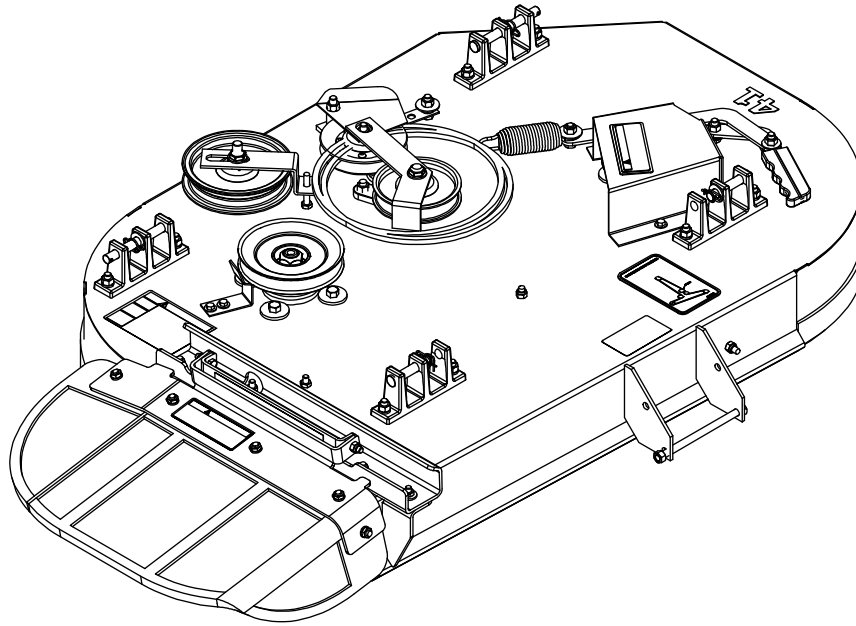

## COMPLETE DECK ASSEMBLY **700A-002A**

Parts List		Parts List	
PART NUMBER	DESCRIPTION	PART NUMBER	DESCRIPTION
609-183P	BUSHING	F-1125	5/16-18 Lock Nut
620-201P	WASHER, BEARING CAP	F-1177	3/8-16 x 1-1/2" Carriage Bolt
643-016W	Hanger Weldment	F-1239	3/8 LOCKNUT
660-076P	ROLLER	F-1274	3/8-16 X 1" CARRIAGE BOLT
660-081P	EXTENSION FOR SPRING	F-1394	3/8-16 x 1" Capscrew
660-110P	BELT KEEPER, B BELT	F-1521	1/2" WASHER, CUSTOM
660-114P	BELT KEEPER, SINGLE END	F-1671	5/16-18 x 3/4" CARRIAGE BOLT
660-119P	IDLER ARM 1/2" OFFSET	F-1672	3/8-16 x 1-1/4" Carriage Bolt
661-045P	ARM, BELT TENSION	F-1707	5/16-18 x 2 1/4" CARRIAGE BOLT,
668-021P	SPACER, BELT GUARD	F-1733	1/4" x 1/2" DRIVE SCREW
668-029P	BELT GUARD	F-1741	3/8-16 x 6" Capscrew
686-097W	BAFFLE, DISCHARGE WLDT	F-1822	1/2-13 X 2-1/4" CARRIAGE BOLT
700-008P	SPACER 2.000OD X .531ID X 1.428HT	F-1889	1/2 x 2-5/8" Clevis Pin
700-014P	DOUBLE IDLER MOUNT .956 HGT	F-1930	Carriage Bolt: Short NK: 5/16-18 X 3/4" L GR5
700-015P	MOUNTING PIN	F-1966	1/2-13 THIN NYLOC NUT
700-044P	ARM, SPRING TENSION	F-1976	3/8-16 x 2" Carriage Bolt
700-058P	GUIDE, BELT 41"	F-2030	1/4 x 5/8 Self Tapping Capscrew
700-060A	PULLEY COVER ASSEMBLY	F-2079	CARRIAGE BOLT 1/2-13 X 4"
700A-003W	41" DECK WELDMENT	F-2082	3/8-16 X 1 3/4" CARRIAGE BOLT
D-3338	Pulley flat idler 1/2" Bore 4"	F-2083	WASHER, 3/8 FENDER
D-3730	Flanged Bushing 5/8" Bore	H-1926	1/4"x1" Handle Grip
D-3758	PULLEY V-IDLER 4.48 O.D. 3/8 HOLE	H-2239	1/2" Rue Ring
D-3774	IDLER PULLEY 5"	H-2240	1/2" x 4-1/2" Clevis Pin
D-3796	"V"-BELT B-124	H-2619	SPRING, 5 X 1-1/2, TAPERED ENDS
F-1005-02	5/16-18 Nyloc Nut	P-10935	Decal, WARNING
F-1005-03	3/8-16 Lock Nut	P-10941	DECAL "DANGER ROTATING BLADES"
F-1009-02	5/16" Flat Washer	P-11413	DECAL, HOIST POINT
F-1009-03	3/8" Flat Washer	P-12711	DECAL, DECK SIZE, 41
F-1015-14	5/16-18 x 7/8" Capscrew	P-12712	DECAL WRANGLER BELT ROUTING
F-1019-03	3/8" LOCKWASHER		

# SPINDLE ASSEMBLY

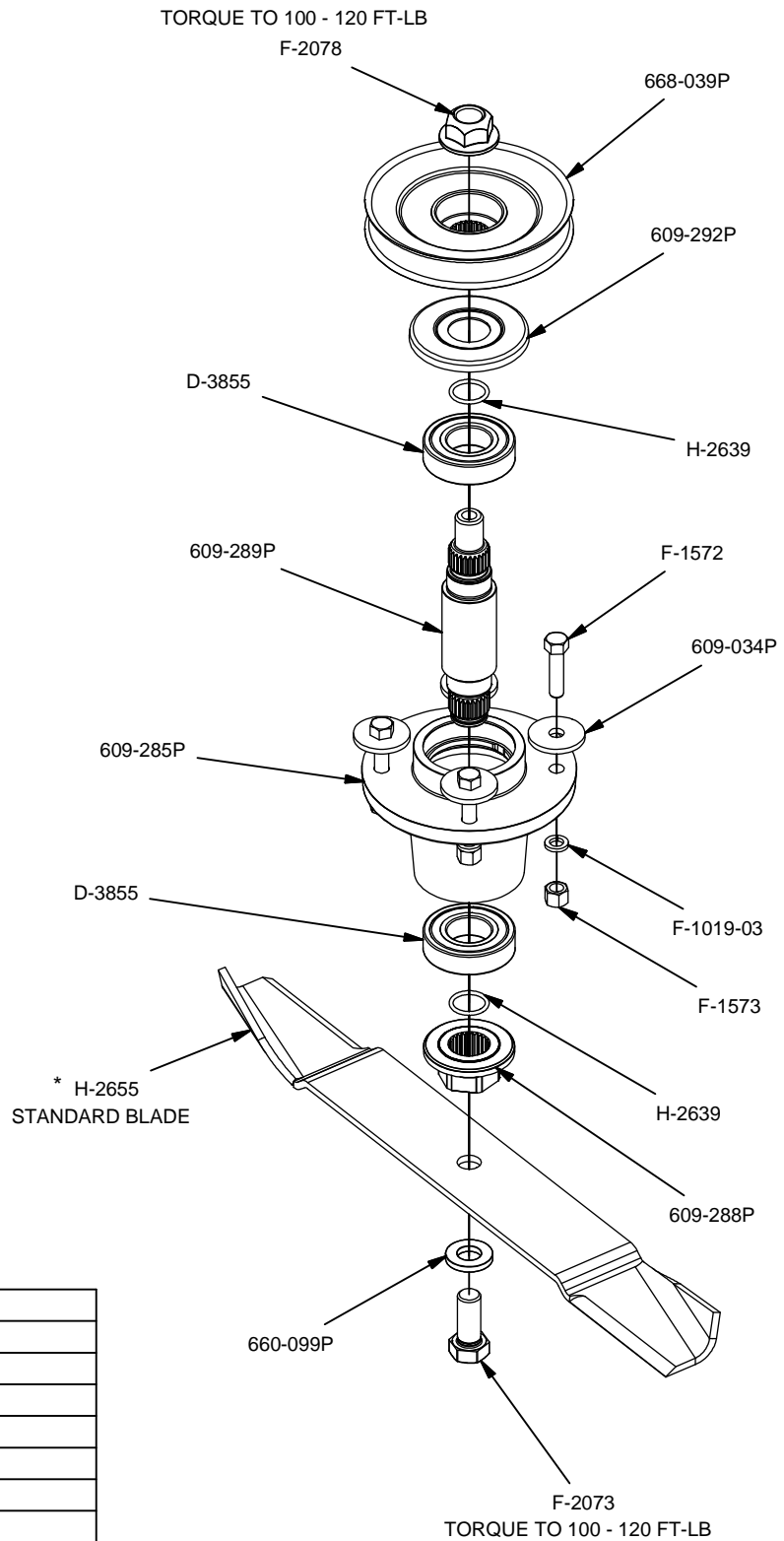

COMPLETE SPINDLE ASSEMBLY  
WITHOUT BLADE AND PULLEY:  
**629FN-001A**

Parts List	
PART NUMBER	DESCRIPTION
609-034P	Spindle Spacer Washer
609-285P	CASTING,HSG,SPINDLE,HD
609-288P	DRIVER,BLADE,FRICITION,SPL
609-289P	SHAFT,SPINDLE,HD
609-292P	CAP,BEARING
660-099P	WASHER,BLADE,5/8
668-039P	PULLEY,OFFSET,A-B,SPLINED
D-3855	BRG,BALL,6206,DOUBLE LIP SEALS
F-1019-03	3/8" LOCKWASHER
F-1572	3/8-24 x 1.5" Capscrew
F-1573	3/8-24 LOCKNUT
F-2073	HHCS,5/8-11X1.50,GR8,YZ
F-2078	NUT,3/4-16,TOP LOCK,GR-GT,YZ
H-2639	O'RING,-117,70 DURO
H-2655	BLADE, 20.953 X .63, HIGH LIFT
H-2707	GREASE, RYKOTAC 1/2 OZ. PACKET

**\* OPTIONAL BLADE INFORMATION:**

H-2649 - FUSION HIGH LIFT  
H-2661 - LOW LIFT  
H-2667 - GATOR BLADE

- APPLIED TO THE TOP OF THE TOP BEARING.

# RUBBER CHUTE ASSEMBLY

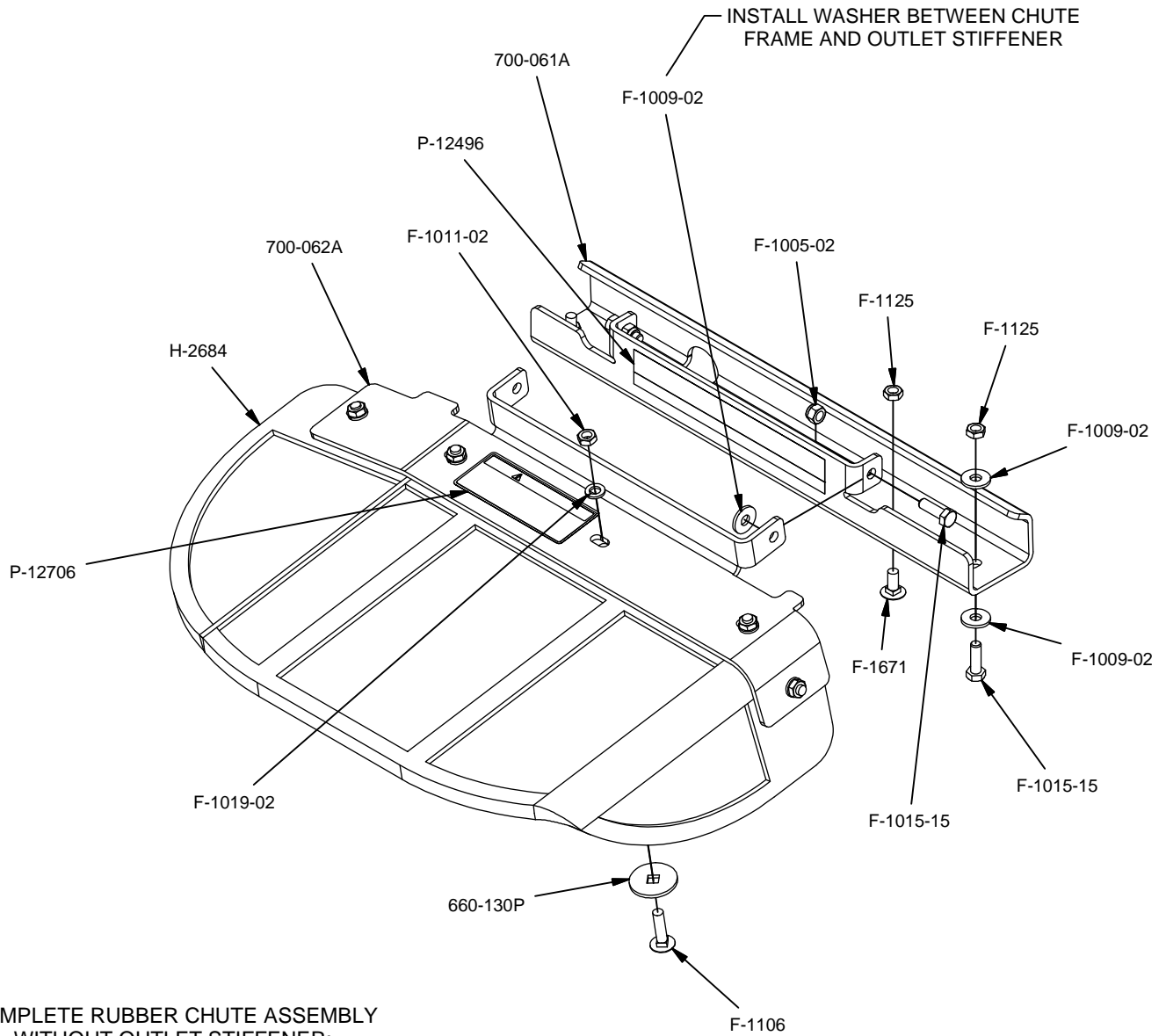

COMPLETE RUBBER CHUTE ASSEMBLY  
WITHOUT OUTLET STIFFENER:

## **660-122A**

Parts List	
PART NUMBER	DESCRIPTION
660-130P	RUBBER CHUTE WASHER
700-061A	OUTLET STIFFENER ASSEMBLY
700-062A	CHUTE FRAME ASSEMBLY, SMALL
F-1005-02	5/16-18 Nyloc Nut
F-1009-02	5/16" Flat Washer
F-1011-02	5/16-18 Nut
F-1015-15	5/16-18 x 1" Capscrew
F-1019-02	5/16" LockWasher
F-1106	5/16-18 x 1-1/4" CARRIAGE BOLT
F-1125	5/16-18 Lock Nut
F-1671	5/16-18 x 3/4" CARRIAGE BOLT
H-2684	RUBBER CHUTE, 24" MOLDED
P-12496	DECAL, MISSING CHUTE
P-12706	WARNING DECAL, DISCHARGE CHUTE

# DECK LIFT ASSEMBLY

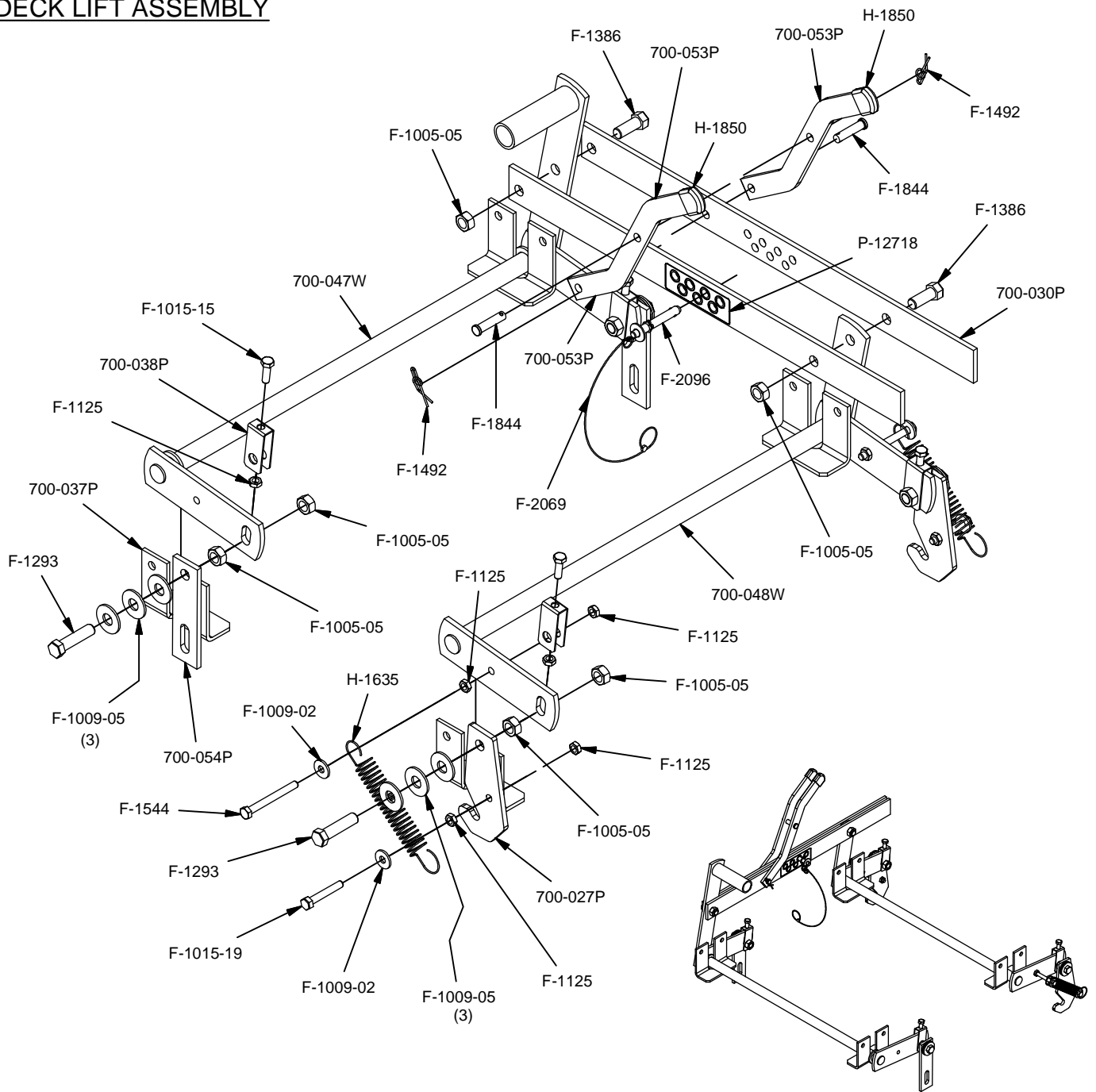

Parts List		Parts List	
PART NUMBER	DESCRIPTION	PART NUMBER	DESCRIPTION
700-027P	HANGER, REAR	F-1015-19	5/16-18 x 2" Capscrew
700-030P	LIFT BAR LINK	F-1125	5/16-18 Lock Nut
700-037P	HANGER BRACKET, FLANGED	F-1293	1/2-13 x 2" Capscrew
700-038P	ADJUSTMENT SHACKLE	F-1386	1/2-13 x 1-1/4" Capscrew
700-047W	DECK LIFT WLDMT, FRONT	F-1492	5/16-3/8 Rue Ring
700-048W	DECK LIFT WLDMT, REAR	F-1544	5/16-18 x 3" Capscrew
700-053P	HEIGHT ADJUSTMENT HANDLE	F-1844	3/8 X 1-1/2 CLEVIS PIN
700-054P	HANGER PLATE	F-2069	PLASTIC LANYARD
F-1005-05	1/2-13 Lock Nut	F-2096	LOCK PIN, POSITIVE 3/8 X 1-1/2
F-1009-02	5/16" Flat Washer	H-1635	3/4x4" Extension Spring
F-1009-05	1/2" FLAT WASHER	H-1850	GRIP, VINYL
F-1015-15	5/16-18 x 1" Capscrew	P-12718	CUT HEIGHT DECAL, WRANGLER

# FRONT END ASSEMBLY

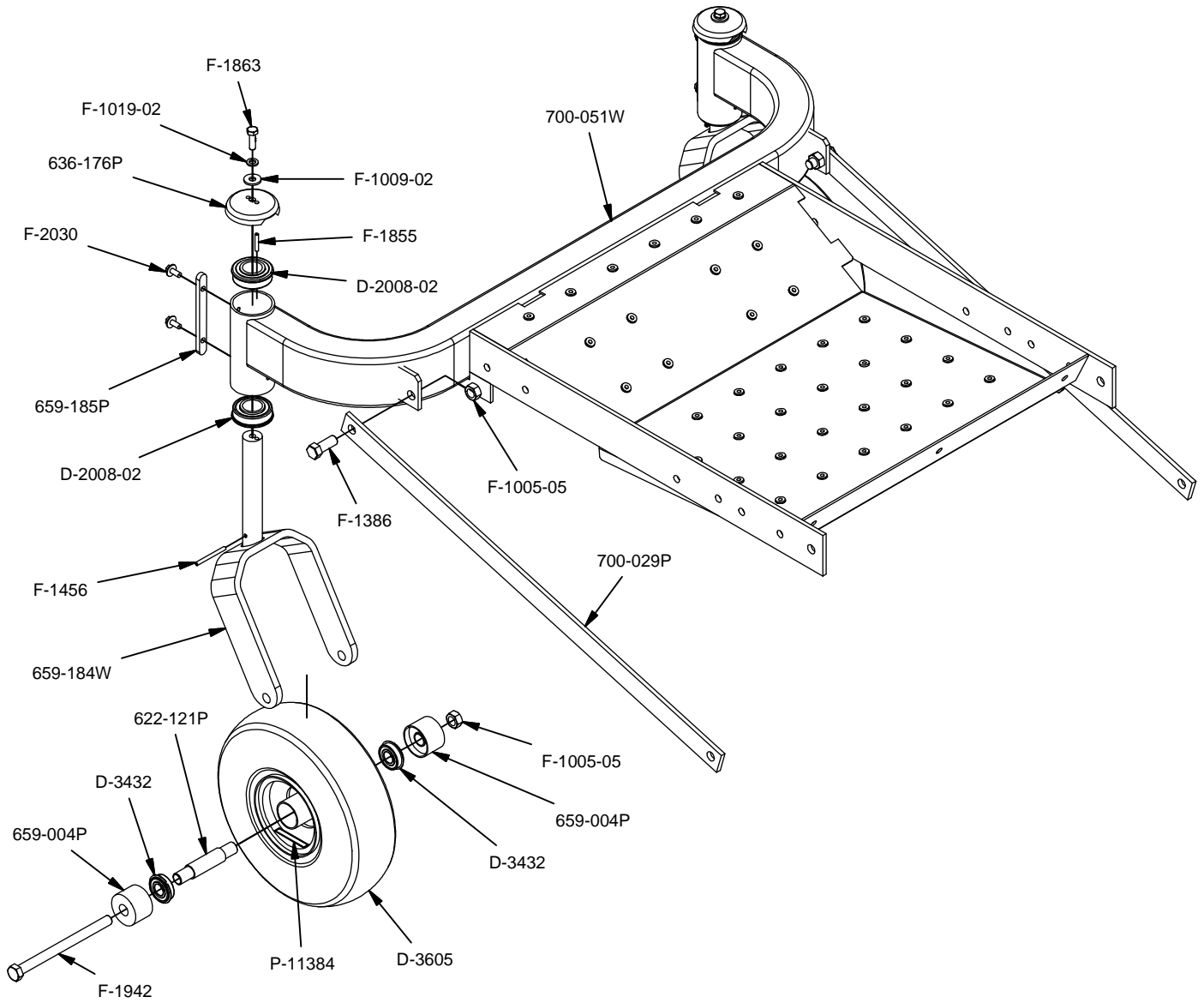

Parts List		Parts List	
PART NUMBER	DESCRIPTION	PART NUMBER	DESCRIPTION
622-121P	Bearing Spacer	F-1005-05	1/2-13 Lock Nut
636-176P	Caster Cap	F-1009-02	5/16" Flat Washer
659-004P	Bearing Shield	F-1019-02	5/16" LockWasher
659-184W	Caster Mount Weldment	F-1386	1/2-13 x1-1/4" Capscrew
659-185P	Stop Tab	F-1456	3/16 x 2" Spiral Pin
700-029P	DRAG BAR	F-1855	3/16 x 1" Roll Pin (Heavy Duty)
700-051W	FRONT AXLE WELDMENT	F-1863	5/16-18 x 1" Capscrew W/PATCH
D-2008-02	Bearing SF-16-32	F-1942	1/2-13 x 6-1/2" Capscrew
D-3432	Bearing 5/8" I.D. 1-3/8" O.D.	F-2030	1/4 x 5/8 Self Tapping Capscrew
D-3605	Caster tire	P-11384	Tire Pressure decal



# FRAME AND SIDE ASSEMBLY

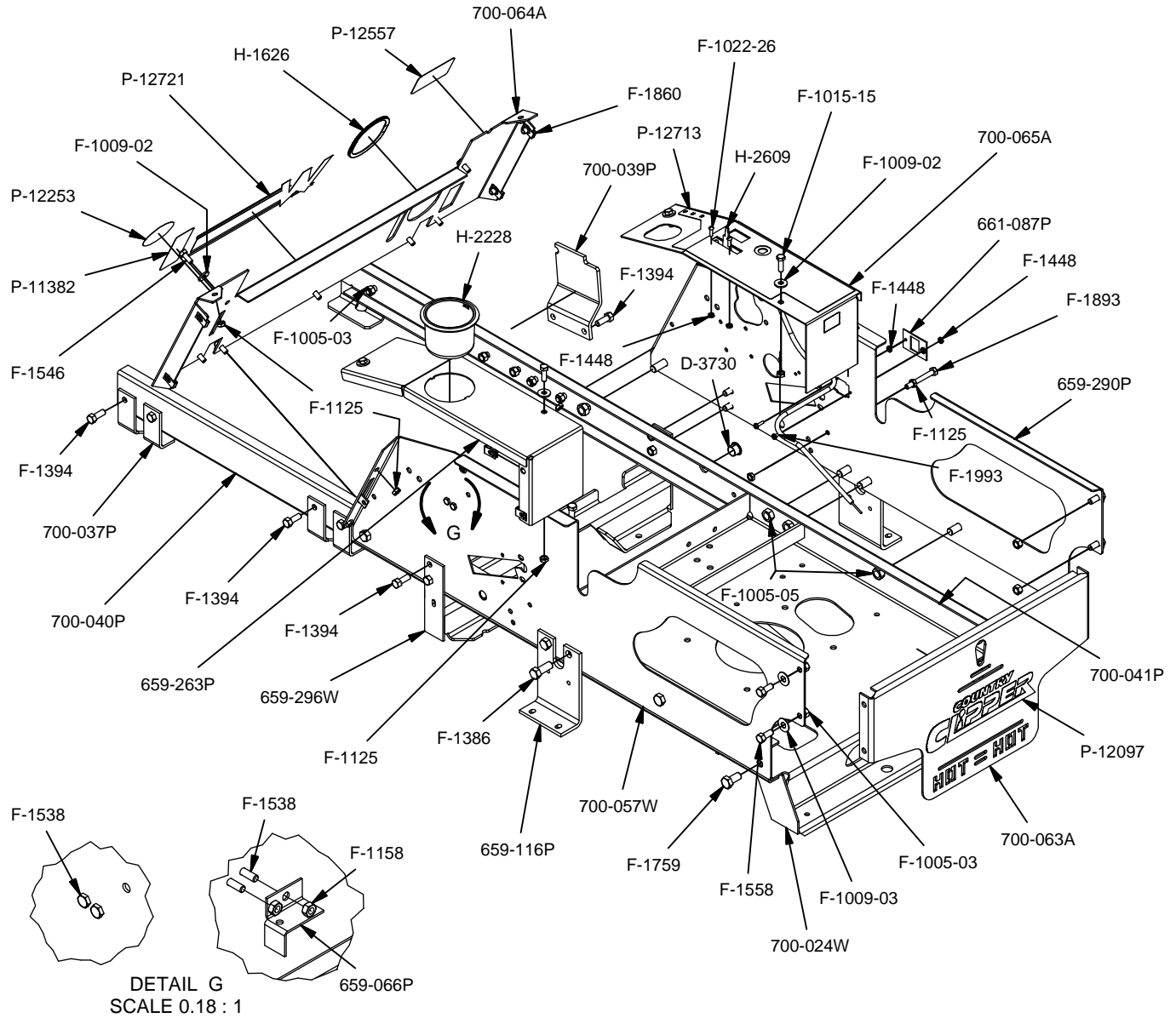

OUTSIDE SIDE PANEL

INSIDE SIDE PANEL

Parts List		Parts List		Parts List	
PART NUMBER	DESCRIPTION	PART NUMBER	DESCRIPTION	PART NUMBER	DESCRIPTION
659-066P	Tank Mount Clamp	700-065A	FENDER CAP ASSEMBLY, RH	F-1860	5/16-18 UNut
659-116P	Hydro Mount Bracket	F-1005-03	3/8-16 Lock Nut	F-1893	5/16-8 x 2-1/2 Capscrew
659-263P	Joystick LH Fender Cap	F-1009-02	5/16" Flat Washer	F-1993	#10-32 x 5/8 Phillips P.H.C.S.
659-290P	PANEL,SIDE,R	F-1009-03	3/8" Flat Washer	H-2228	Cup Holder
659-296W	WLDT,Transmission Brace	F-1015-15	5/16-18 x 1" Capscrew	H-2609	Throttle cable
661-087P	Fuse Mount Plate	F-1022-26	10-32 x 5/8" MachineScrew	P-10777	Patent Number decal
700-024W	Motor Mount Wldmt	F-1125	5/16-18 Lock Nut	P-11382	Brake On-Off Decal
700-037P	Hanger Bracket, Flanged	F-1158	1/4-20 Lock Nut	P-12097	Country Clipper decal
700-039P	LATCH STOP PLATE	F-1386	1/2-13 x1-1/4" Capscrew	P-12253	Made In The U.S.A. Decal
700-040P	FRAME RAIL (L)	F-1394	3/8-16 x 1" Capscrew	P-12557	Caution Fuel Decal
700-041P	FRAME RAIL (R)	F-1448	10-32 Nyloc Locknut	P-12713	Control Panel Decal
700-057W	SIDE PANEL WLDMT, LH	F-1546	5/16-18 x 3/4" Capscrew	P-12721	DECAL, WRANGLER
700-063A	Rear Engine Guard Assembly	F-1558	3/8-16 x 7/8" Capscrew		
700-064A	FRONT PANEL ASSEMBLY	F-1759	1/2-13 x 1" Capscrew		

# SEAT AND RELATED PARTS

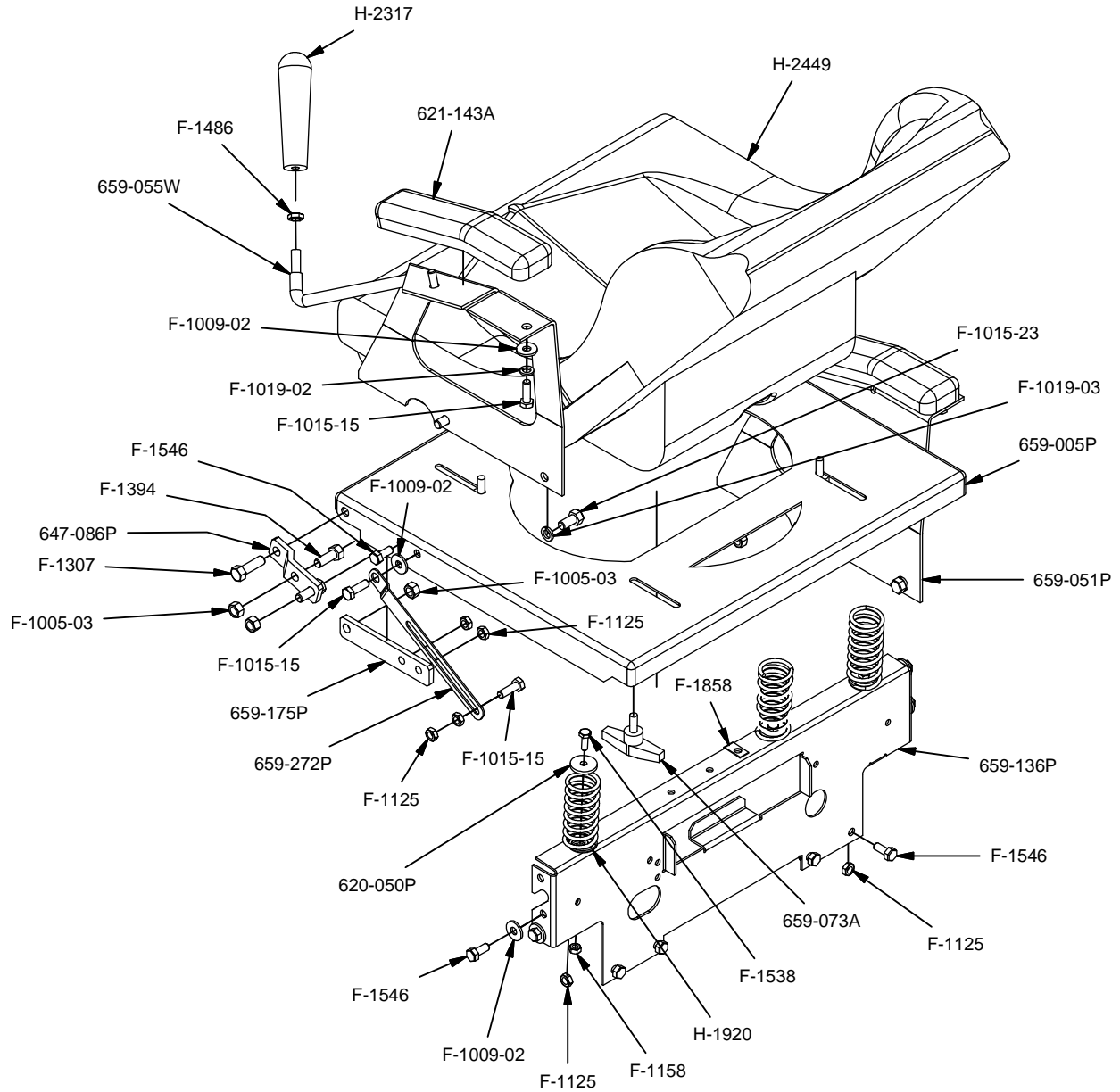

Parts List		Parts List	
PART NUMBER	DESCRIPTION	PART NUMBER	DESCRIPTION
620-050P	Washer	F-1019-02	5/16" LockWasher
621-143A	Arm Rest Pad	F-1019-03	3/8" LOCKWASHER
647-086P	FLIP SEAT MTG. TAB	F-1125	5/16-18 Lock Nut
659-005P	Seat Mounting Base	F-1158	1/4-20 Lock Nut
659-051P	ARM REST MOUNT RH	F-1307	3/8-16 x 1-1/4" Capscrew
659-055W	ARM REST MOUNT LH	F-1394	3/8-16 x 1" Capscrew
659-073A	T HANDLE ASSEMBLY	F-1486	3/8-16 Jam Nut
659-136P	Seat Spring Support	F-1538	1/4-20 x 3/4" Capscrew
659-175P	Seat Hinge Tab	F-1546	5/16-18 x 3/4" Capscrew
659-272P	BAR,SEAT STOP	F-1858	1/4-20 "U"-Nut
F-1005-03	3/8-16 Lock Nut	H-1920	Seat Spring
F-1009-02	5/16" Flat Washer	H-2317	Handle Grip, Tapered
F-1015-15	5/16-18 x 1" Capscrew	H-2449	Millsco Seat
F-1015-23	3/8-16 x 3/4" Capscrew		

# JOYSTICK ASSEMBLY

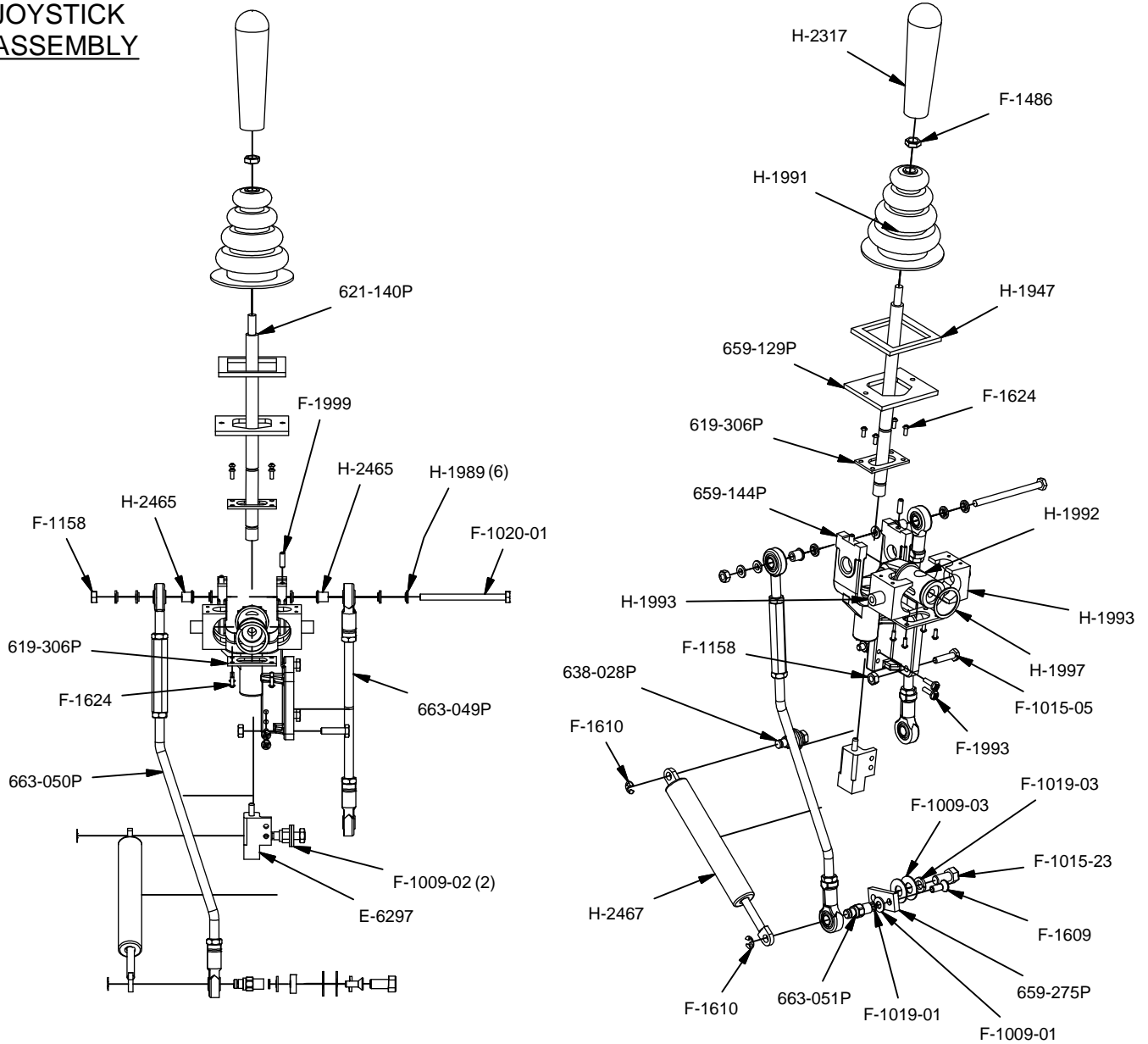

Parts List		Parts List	
PART NUMBER	DESCRIPTION	PART NUMBER	DESCRIPTION
619-306P	Pivot Block Plate	F-1020-01	1/4-20 x 3-1/2" Capscrew
621-140P	Joystick Shaft Assembly	F-1158	1/4-20 Lock Nut
638-028P	Damper Bolt, 5/16-18 X 3/4"	F-1486	3/8-16 Jam Nut
659-129P	Joystick Top Plate	F-1609	1/4-20 x 3/4" F.H.C.S.
659-144P	JOYSTICK LEVER CONTROL YOKE	F-1610	E-Ring for 1/4" Shaft
659-275P	Tracking Adjustment Cam	F-1624	#6 X 3/8" Screw
663-049P	Steering Link, Short	F-1993	#10-32 x 5/8 Phillips P.H.C.S.
663-050P	Steering Link, Long	F-1999	Roll Pin, 3/16 X 5/8
663-051P	Damper Stud (Female)	H-1947	Gasket, Foam
E-6297	Brake Switch	H-1989	Ball Joint Bushing
F-1009-01	1/4" Flat Washer	H-1991	JoyStick Boot
F-1009-02	5/16" Flat Washer	H-1992	Pivot Shaft
F-1009-03	3/8" Flat Washer	H-1993	Pivot Block
F-1015-05	1/4-20 x 1" Capscrew	H-1997	Snap Ring
F-1015-23	3/8-16 x 3/4" Capscrew	H-2317	Grip Handle, Tapered
F-1019-01	1/4" LockWasher	H-2465	1/4" x 1/2" Shoulder Washer
F-1019-03	3/8" LOCKWASHER	H-2467	Dual Action Damper

JOYSTICK ASSEMBLY:  
**647-122A**

JOYSTICK REPAIR KIT:  
**612-332A**

# JOYSTICK STEERING ASSEMBLY

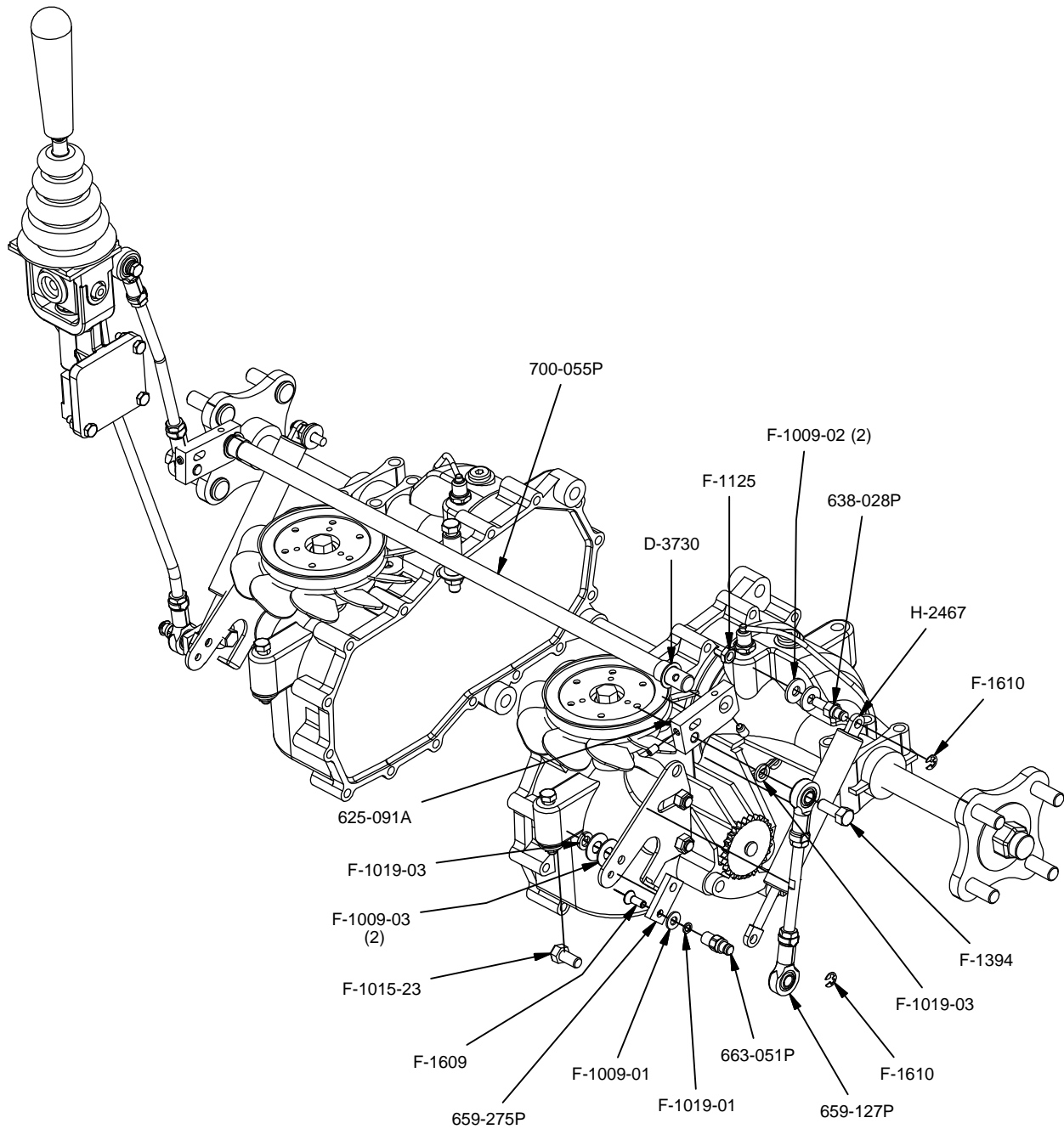

Parts List		Parts List	
PART NUMBER	DESCRIPTION	PART NUMBER	DESCRIPTION
625-091A	ARM, SWIVEL, S/A	F-1009-03	3/8" Flat Washer
638-028P	Damper Bolt, 5/16-18 X 3/4"	F-1015-23	3/8-16 x 3/4" Capscrew
659-127P	Linkage Rod (Short)	F-1019-01	1/4" LockWasher
659-275P	Tracking Adjustment Cam	F-1019-03	3/8" LOCKWASHER
663-051P	Damper Stud (Female)	F-1125	5/16-18 Lock Nut
700-055P	ROD, SHIFT CROSS	F-1394	3/8-16 x 1" Capscrew
D-3730	Flanged Bushing 5/8" Bore	F-1609	1/4-20 x 3/4" F.H.C.S.
F-1009-01	1/4" Flat Washer	F-1610	E-Ring for 1/4" Shaft
F-1009-02	5/16" Flat Washer	H-2467	Dual Action Damper

# BRAKE ASSEMBLY

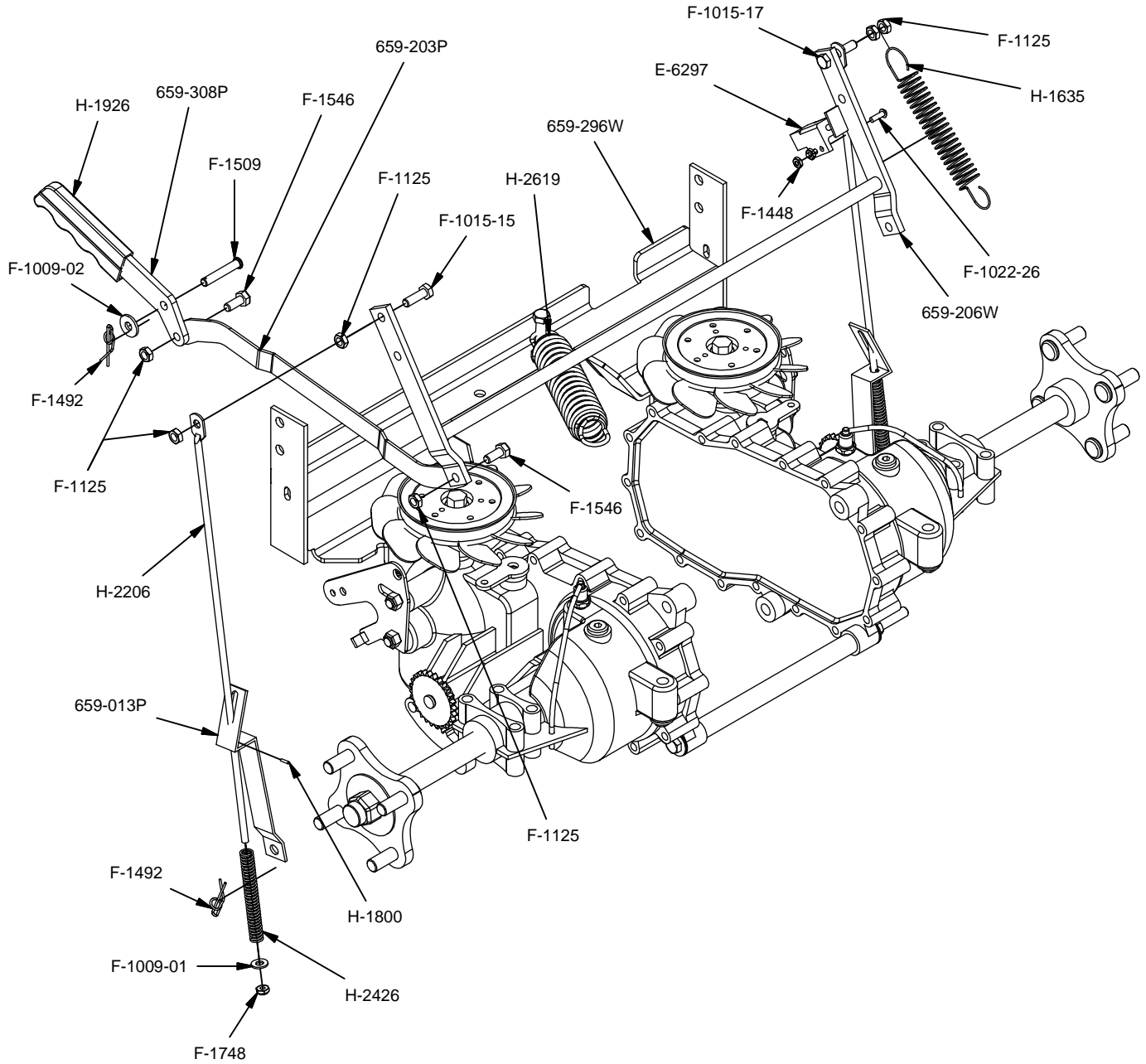

Parts List		Parts List	
PART NUMBER	DESCRIPTION	PART NUMBER	DESCRIPTION
659-013P	Lower Brake Link	F-1448	10-32 Nyloc Locknut
659-203P	BRAKE LINK	F-1492	5/16-3/8 Rue RIng
659-206W	BRAKE ROD WLDT	F-1509	5/16 x 1 3/4" Clevis Pin
659-296W	WLDT,TRANSMISSION BRACE	F-1546	5/16-18 x 3/4" Capscrew
659-308P	BRAKE HANDLE, FLAT	F-1748	1/4-20 thin nyloc nut
E-6297	Brake Switch	H-1635	3/4x4" Extention Spring
F-1009-01	1/4" Flat Washer	H-1800	3/32 x 3/8" Roll Pin
F-1009-02	5/16" Flat Washer	H-1926	1/4"x1" Handle Grip
F-1015-15	5/16-18 x 1" Capscrew	H-2206	Brake Link Rod
F-1015-17	5/16-18 x 1-1/2" Capscrew	H-2426	.372 x 3.69 Spring
F-1022-26	10-32 x 5/8" MachineScrew	H-2619	SPRING,5 X 1-1/2,TAPERED ENDS
F-1125	5/16-18 Lock Nut		

# FUEL TANK ASSEMBLY

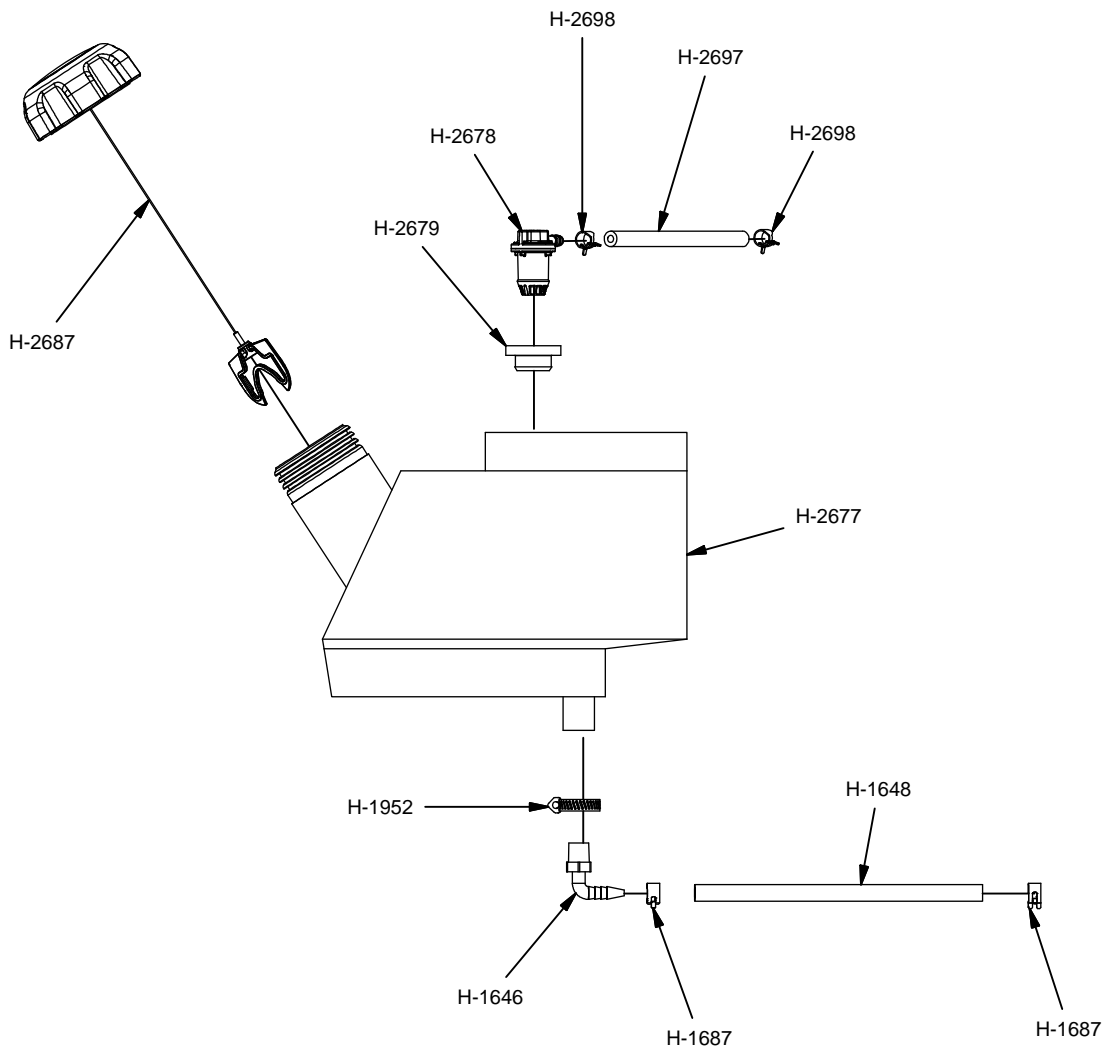

FUEL TANK ASSEMBLY:  
**659-306A**

Parts List	
PART NUMBER	DESCRIPTION
H-1646	1/4 x 1/4" 90 Degree Nylon Elbow
H-1648	Fuel Line
H-1687	1/2 O.D. Hose Spring Clamp
H-1952	1.87" Hose Clamp
H-2677	Gas Tank, 4 1/2 Gallon Vented
H-2678	Remote Vent
H-2679	KELCH REMOTE VENT GROMMET
H-2687	Ratchet Cap w/ 8" Tether
H-2697	HOSE, FUEL LINE .188 ID X .406 OD
H-2698	CLAMP, .406 OD FUEL LINE

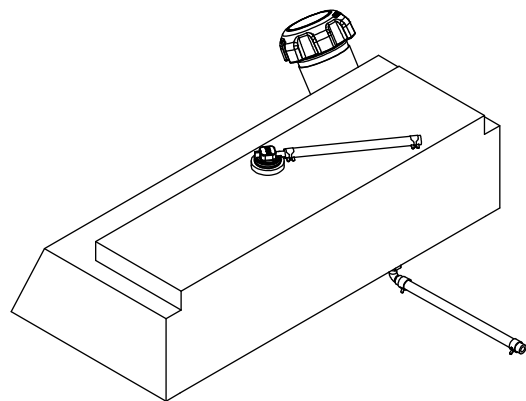

# UNDERSIDE OF MOTOR MOUNT

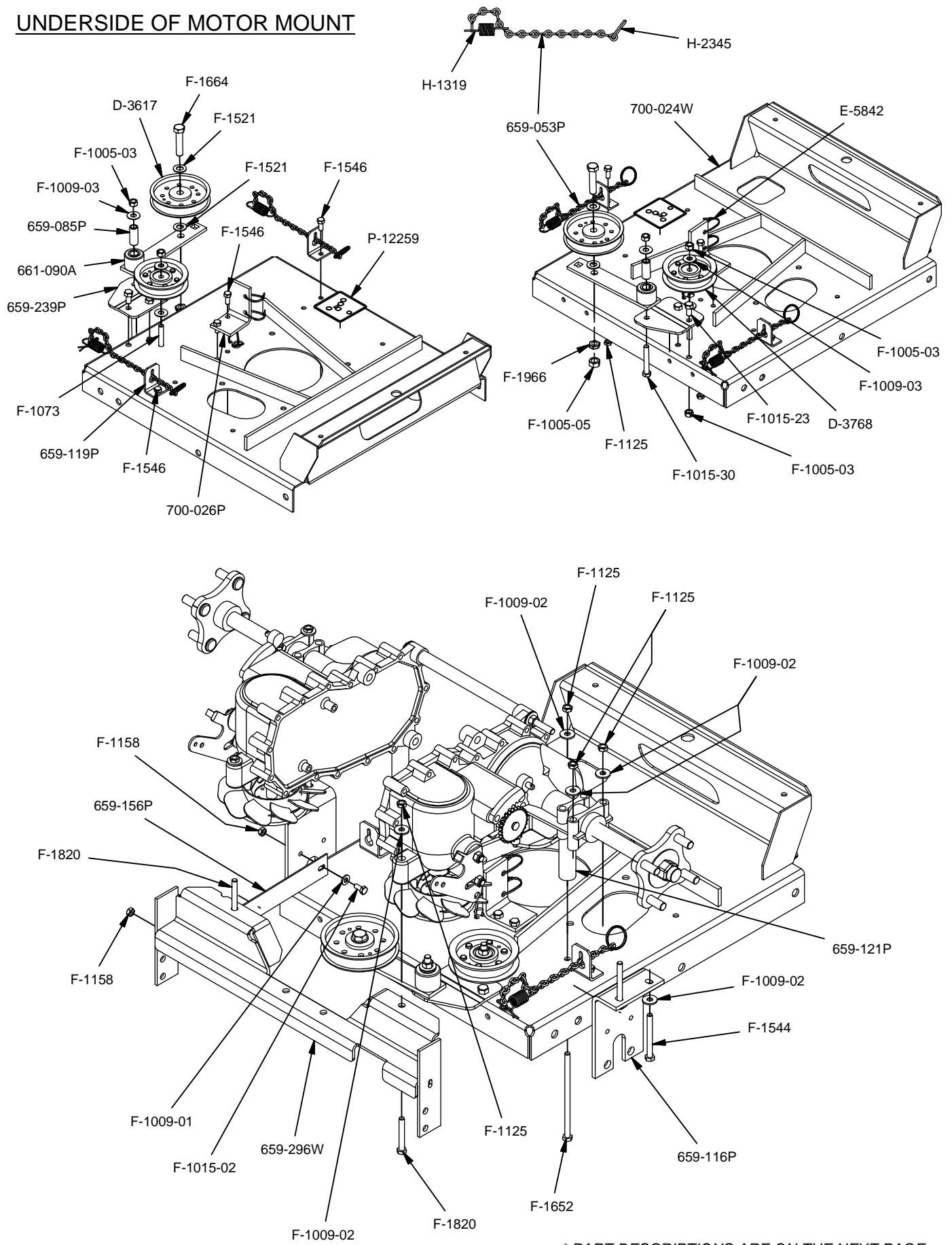

\* PART DESCRIPTIONS ARE ON THE NEXT PAGE.

# MOTOR AND MOUNT ASSEMBLY

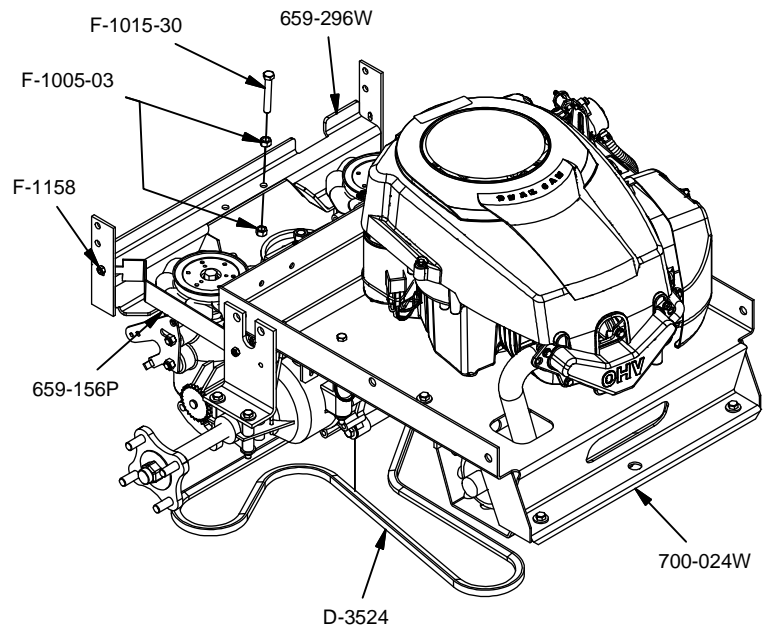
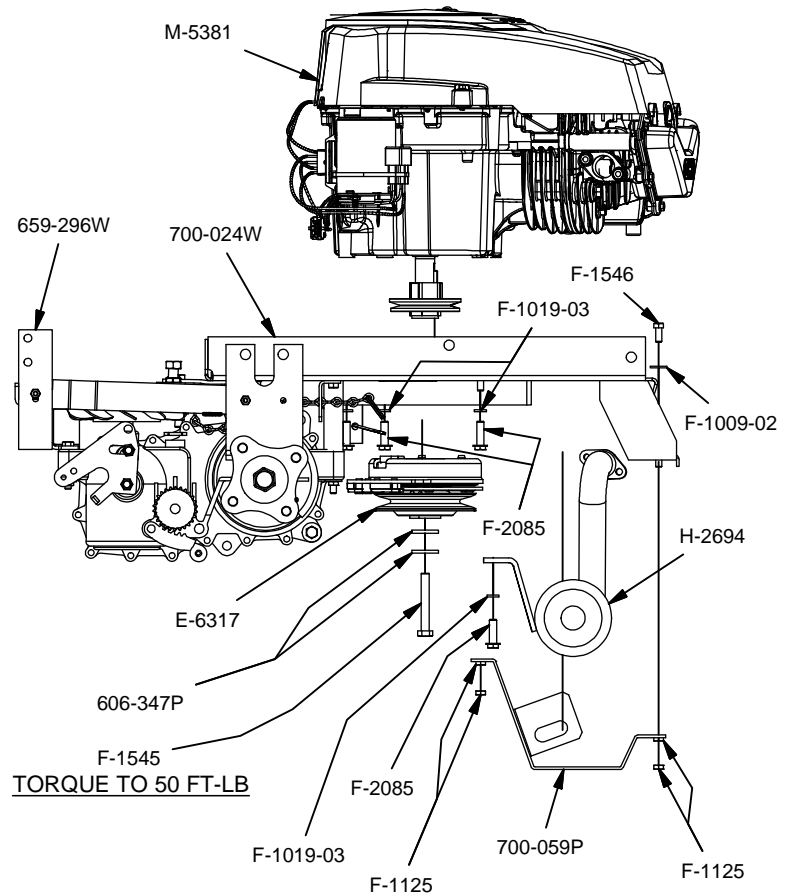

Parts List	
PART NUMBER	DESCRIPTION
606-347P	15/32" ID WASHER
659-085P	Mounting Pin
659-116P	Hydro Mount Bracket
659-119P	Free Wheel Anchor
659-121P	Rear Hydro Brace
659-156P	Fan Shroud
659-239P	Bolt On Idler Mount Tab
659-296W	WLDT, TRANSMISSION BRACE
661-066P	Free Wheel Chain
661-090A	Idler Arm Assembly
700-024W	Motor Mount Wldmt 18.5 & 20HP
700-026P	CLUTCH STOP
700-059P	MUFFLER GUARD
D-3524	Kevlar "V"-Belt #A-71
D-3617	4" Idler Pulley 1/2" Bore
D-3768	Pulley 3.5 X 1" wide
E-5842	Wire Tie
E-6317	Clutch/Brake 1" Bore
F-1005-03	3/8-16 Lock Nut
F-1005-05	1/2-13 Lock Nut
F-1009-01	1/4" Flat Washer
F-1009-02	5/16" Flat Washer
F-1009-03	3/8" Flat Washer
F-1015-02	1/4-20 x 5/8" Capscrew
F-1015-23	3/8-16 x 3/4" Capscrew
F-1015-30	3/8-16 x 2-1/2" Capscrew
F-1019-03	3/8" LOCKWASHER
F-1125	5/16-18 Lock Nut
F-1158	1/4-20 Lock Nut
F-1492	5/16-3/8 Rue RIng
F-1521	1/2" WASHER, CUSTOM
F-1544	5/16-18 x 3" Capscrew
F-1545	7/16-20 x 3" Capscrew
F-1546	5/16-18 x 3/4" Capscrew
F-1652	5/16-18 x 6" Capscrew
F-1664	1/2-13 x 2-1/4" Capscrew
F-1820	5/16-18 x 2-1/4" Capscrew
F-1966	1/2-13 THIN NYLOC NUT
F-2085	3/8-16 x 1-1/4" Bolt, Self-Tapping
H-1319	Spring
H-2345	Split Ring
H-2694	Muffler for 18.5HP & 20HP Kohler
M-5381	KOHLER 18 HP Single Cylinder
P-12259	Belt Routing Decal



# MOTOR AND TRANSAXLE

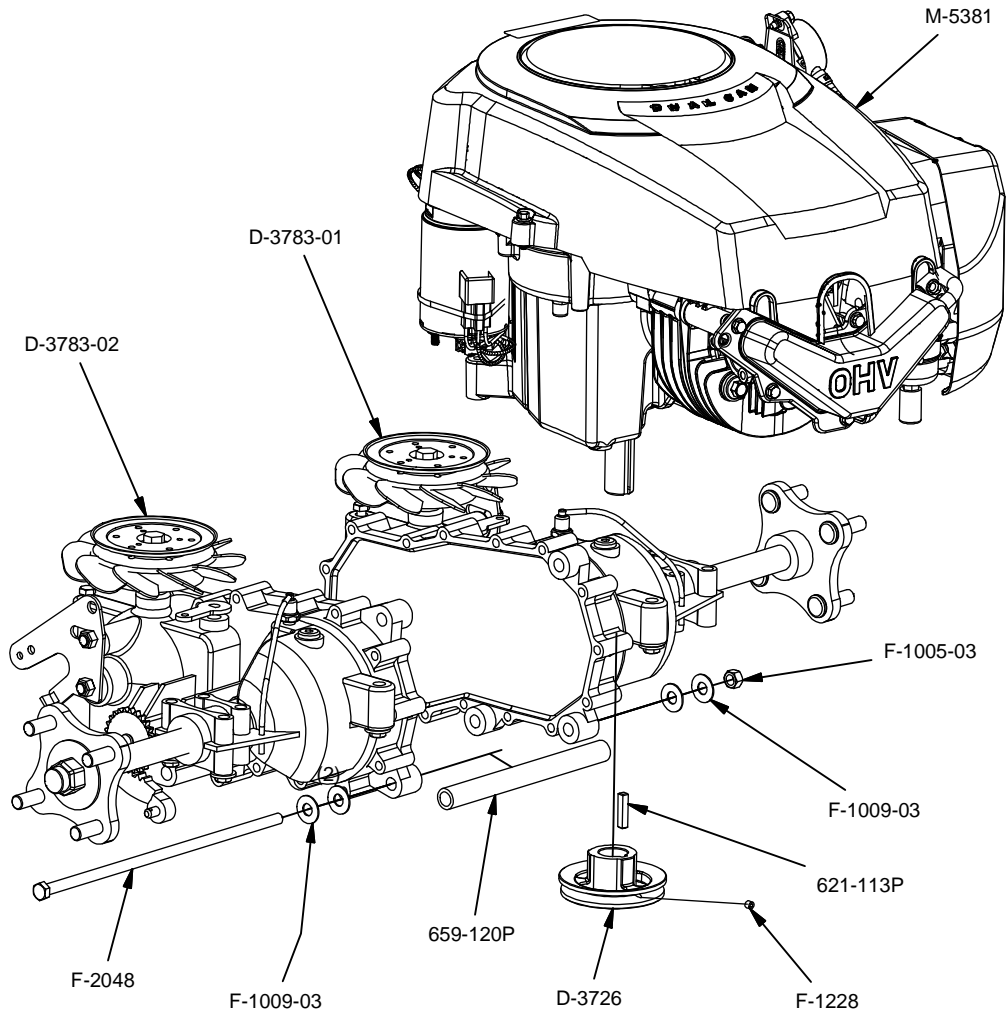

Parts List	
PART NUMBER	DESCRIPTION
621-113P	1/4"sq x 1-1/4" Key
659-120P	Hydro Brace
D-3726	Engine Pulley 3.75"
D-3783-01	Transaxle 7" Fan LH
D-3783-02	Transaxle 7" Fan RH
F-1005-03	3/8-16 Lock Nut
F-1009-03	3/8" Flat Washer
F-1228	1/4-20 x 1/4" Set Screw W/Nylon Patch
F-2048	3/8-16 x 12" Hex Bolt
M-5381	KOHLER 18 HP Single Cylinder

# REAR WHEEL AND SIDE PANEL

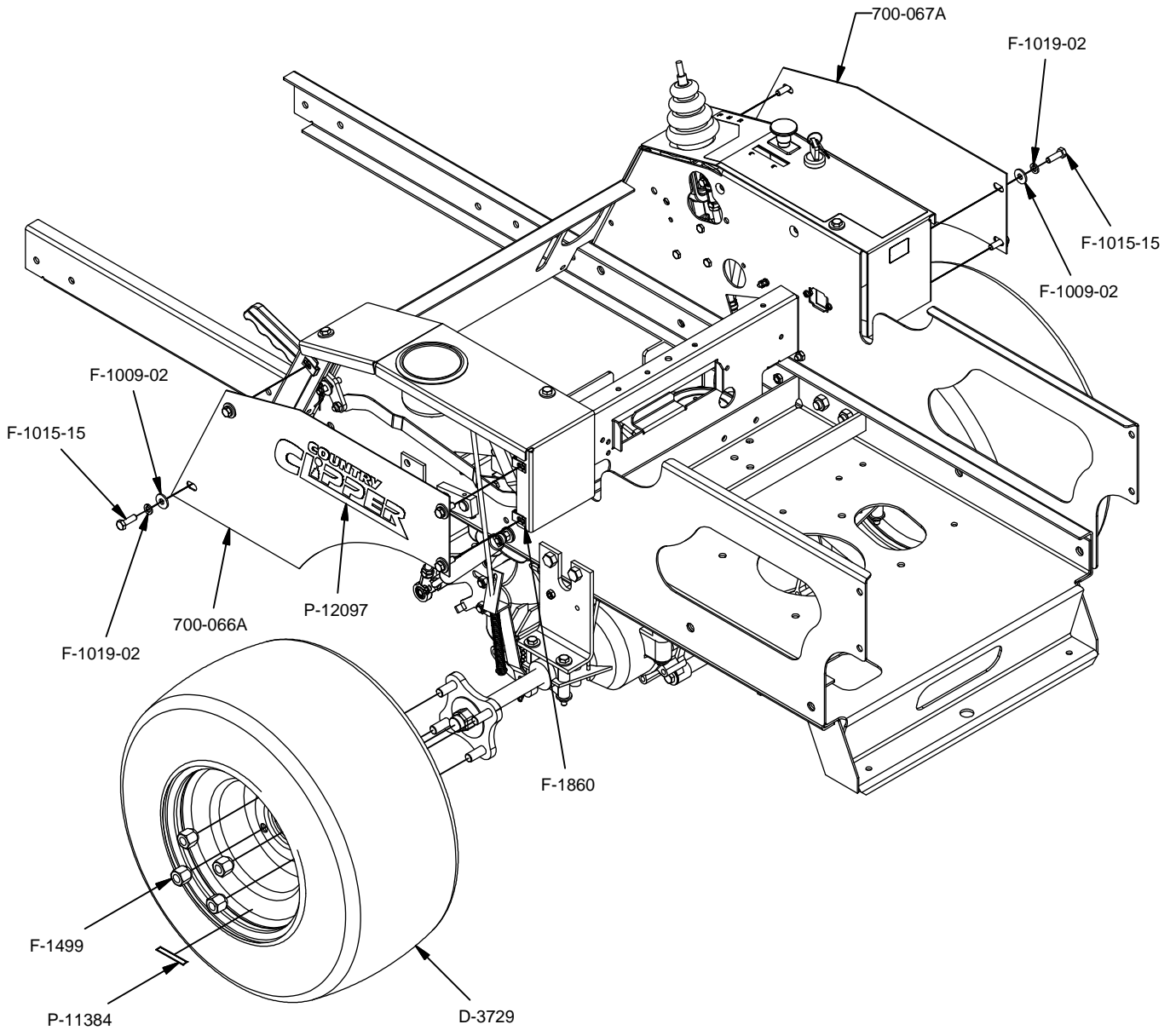

Parts List

PART NUMBER	DESCRIPTION
700-066A	Fender Skirt Assembly, LH
700-067A	Fender Skirt Assembly, RH
D-3729	18"x8.8-8" Tire and Rim
F-1009-02	5/16" Flat Washer
F-1015-15	5/16-18 x 1" Capscrew
F-1019-02	5/16" LockWasher
F-1499	1/2-20 Lug Nut
F-1860	5/16-18 UNut
P-11384	Tire Pressure decal
P-12097	Country Clipper decal

# WIRE HARNESS & BATTERY

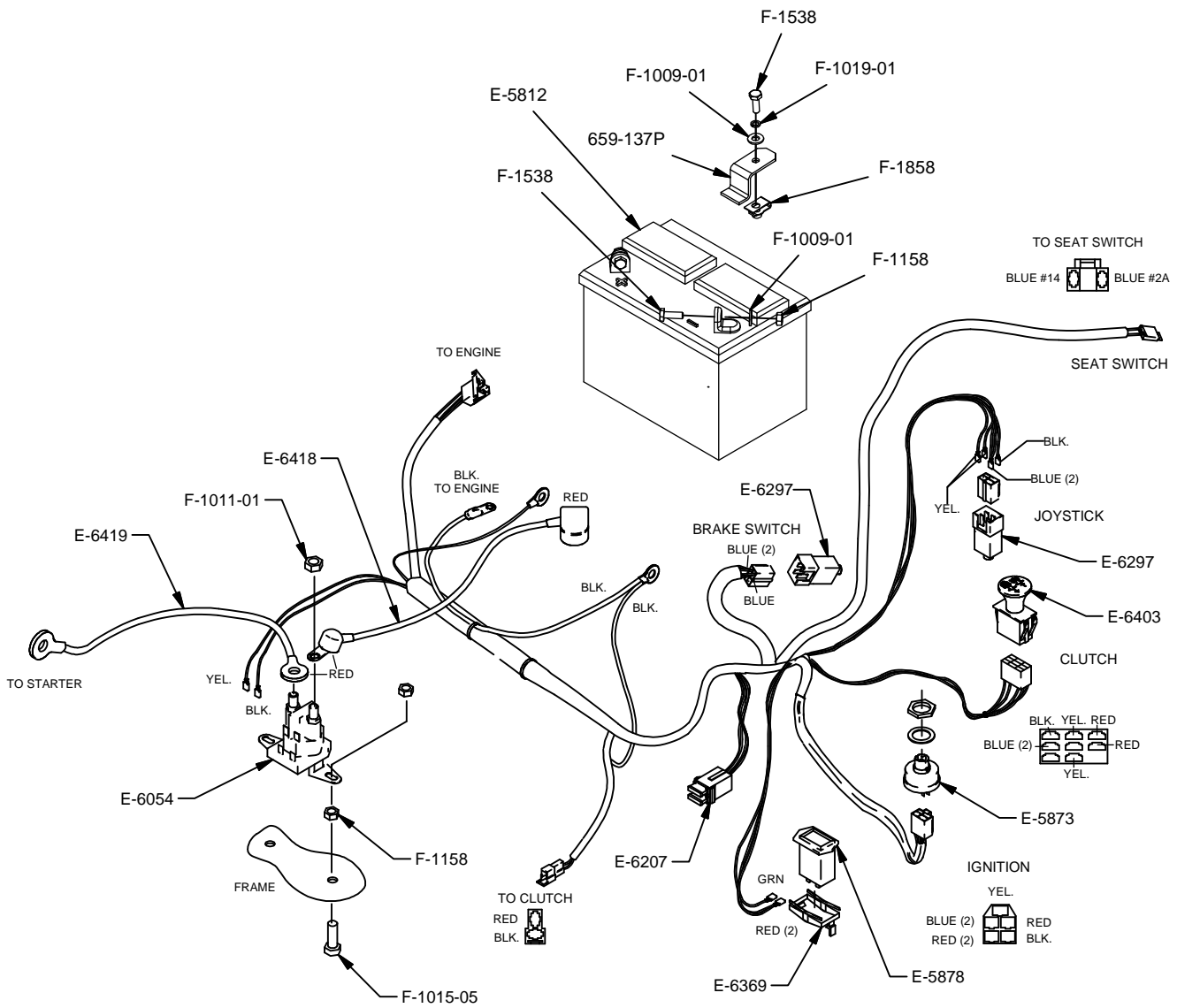

## WIRE HARNESS ASSEMBLY **E-6405**

Parts List		Parts List	
PART NUMBER	DESCRIPTION	PART NUMBER	DESCRIPTION
659-137P	Battery Hold Down	E-6418	CABLE, BATTERY TO SOLENOID
E-5812	12 Volt Battery YSP 30	E-6419	CABLE, SOLENOID TO ENGINE
E-5873	START SWITCH	F-1009-01	1/4" Flat Washer
E-5878	HOUR METER	F-1011-01	1/4-20 NUT
E-6054	SOLENOID	F-1015-05	1/4-20 X 1 HHCS
E-6207	FUSE, #ATC-30	F-1019-01	1/4" LockWasher
E-6281	COVER, KEY SWITCH	F-1158	1/4-20 Stover Nut
E-6297	BRAKE SWITCH	F-1538	1/4-20 x 3/4" Capscrew
E-6369	RETAINER CLIP	F-1858	1/4-20 "U"-Nut
E-6403	CLUTCH SWITCH		

