

Safety Instructions & Operators Manual

COUNTRY CLIPPER®

Zero Turn Radius Mower



SR1215

Congratulations for buying a **Country Clipper** product. Your **Country Clipper** Zero Turning Radius Riding Mower was designed and built to provide long and trouble free service. Keep in mind that it, like any other mechanical device, can be potentially dangerous if used improperly, and hazard control and accident prevention are dependent upon the awareness, concern, prudence, and proper training of personnel involved in the operation, transport, maintenance, and storage of the equipment. Study this manual and pay special attention to the important Safety Precautions on pages 3-5. Following these instructions will help you continue to enjoy the trouble-free performance

TABLE OF CONTENTS

I. SAFETY

Accident Patterns to Avoid-----	3
Safety Instructions and Recommendations-----	3-4
Safety Interlock Systems -----	5

II. START UP AND OPERATION

Checklist Before Operation -----	5
Operation – Joystick -----	6-7
Operation – Dual Lever-----	7-8
Mowing Recommendations -----	9

III. MAINTENANCE

Maintenance Schedule -----	10
Maintenance Instructions -----	11-18
Raising and Lowering Deck for Servicing -----	19-20
Leveling the Deck -----	20
Adjusting the Latch Plate-----	21
Deck Flip Jack Assembly and Operation-----	22
Troubleshooting Checklist -----	23-24

IV. Wiring Schematic -----	25-27
----------------------------	-------

SAFETY

ACCIDENT PATTERNS TO AVOID

- I. **CONTACT WITH THE ROTATING BLADE** -- This accident usually happens when the operator is clearing the discharge chute of grass, (especially when the grass is wet), or when the operator adjusts the machine without turning it off and waiting for the blades to completely stop.
- II. **PROPELLED OBJECTS** -- Sticks, rocks, wires, and other objects can be propelled out through the discharge chute or from under the mower housing. Bystanders are particularly vulnerable.
- III. **GRASS CATCHER OR GUARD** -- The mower shall not be operated without either the entire grass catcher or guard in place.
- IV. **OVERTURNING** -- This happens when riding mowers are used on steep slopes, embankments or hills. The operator in these cases can come in contact with the blades or sustain injuries during a fall.
- V. **MOWER RUNNING OVER THE VICTIM** -- This usually happens when a riding mower is driven in reverse. The accident victims are most often young children whom, unseen by the operator of the mower, were in the area being mowed.

AT **COUNTRY CLIPPER**, WE SHARE YOUR DESIRE TO PROTECT YOURSELF, YOUR FAMILY, YOUR FRIENDS AND YOUR NEIGHBORS FROM ACCIDENTAL INJURY. OBSERVING AND ENFORCING THE FOLLOWING GUIDELINES WILL HELP TO INSURE THE SAFETY OF EVERYONE.

PLEASE BE CAREFUL!

SAFETY INSTRUCTIONS AND RECOMMENDATIONS

1. **PEOPLE WHO OPERATE, SERVICE, OR ARE OTHERWISE ASSOCIATED** with the **Country Clipper** Zero Turning Radius Mower should be trained in its proper use and warned of its dangers. Before operating, adjusting, or servicing the **Country Clipper** Zero Turning Radius Mower they should read and understand this entire manual and the engine owner's manual.
2. **AVOID CONTACT WITH MOVING PARTS.** Keep hands and feet from under mowing deck and away from blades at all times. Turn engine (motor) off if you must unclog the chute.
3. **AVOID HILLS AND SLOPES.** Use extreme caution when mowing up or down slopes. NEVER mow across the face of a slope. If a slope must be ascended, back up the slope; drive forward when descending. Reduce speed and use caution to start, stop and maneuver. To prevent loss of control on a slope avoid sharp turns, sudden changes in direction, and sudden stops and starts.
4. **DISENGAGE POWER TO MOWER BEFORE BACKING UP.** Do not mow in reverse unless ABSOLUTELY necessary and then only after turning around and observing the entire area behind the mower. Go slowly. Most "running over victim" accidents occur in reverse.
5. **BEGINNING OPERATORS SHOULD LEARN HOW TO STEER** the **Country Clipper** Zero Turning Radius Mower before attempting to mow. Start with slow engine speed and drive without the blades engaged in an open area until comfortable with the machine.
6. **KNOW HOW TO STOP QUICKLY.** Know the location and operation of every control, especially how the brake and how to disengage the mower blades.

7. **DO NOT MOVE CONTROL LEVER(S)** from forward position to reverse position rapidly. The speed and/or direction of travel is affected instantly by movement of the Control Lever(s).
8. **DO NOT ALLOW CHILDREN TO OPERATE MOWER.** Do not allow others who have not had instruction to operate mower.
9. **ALWAYS TURN ENGINE OFF AND REMOVE KEY** before leaving the mower to prevent children and inexperienced operators from starting the engine. Never leave the mower unattended with engine running. Always wait for all moving parts and all sounds to stop before leaving operator's seat.
10. **WEAR STURDY, ROUGH-SOLED WORK SHOES AND CLOSE-FITTING SLACKS AND SHIRTS.** Never operate mower in bare feet, sandals or sneakers.
11. **NEVER CARRY PASSENGERS.**
12. **KNOW THE AREA YOU ARE TO MOW.** Watch for hidden danger such as rocks, roots, sticks, holes, bumps, and drop-offs, etc. Before mowing, pick up all debris in area to be mowed. Sharp and hard objects can be propelled at a high speed and can act like shrapnel. Walk through tall grass **BEFORE MOWING** to make sure there are no hidden dangers. Mow higher than desired in tall grass to expose any hidden objects and/or obstacles, clean the area, and then mow to the desired height.
13. **NEVER REFUEL A MOWER INDOORS.** Allow the engine time to cool before refueling. Unseen vapors may be ignited by a spark. Always clean up spilled gasoline. Never run the engine indoors in a garage or any other closed building. Allow engine to cool before storing in any enclosure. The engine exhaust and gasoline fumes are dangerous.
14. **NEVER REMOVE THE FUEL CAP** or add gasoline to a running or hot engine that has not been allowed to cool for several minutes after running. Always make sure the gas cap is in place.
15. **DO NOT SMOKE AROUND THE MOWER** or the gasoline storage container. Gasoline fumes can easily ignite.
16. **KEEP GASOLINE IN A WELL-VENTILATED AREA** away from your living quarters and in tightly-capped safety cans. Never store mower with gasoline in the tank inside a building where fumes may reach open flame or spark.
17. **DISENGAGE BLADES, STOP ENGINE AND REMOVE IGNITION KEY** before any servicing. Be sure all moving parts and all sounds have stopped. Let engine cool and disconnect the spark plugs so the engine cannot start by accident. A SLIGHT ROTATION OF THE BLADES COULD START THE ENGINE.
18. **KEEP ALL NUTS, BOLTS, AND SCREWS TIGHT** to be sure equipment is in safe working condition, especially blade mounting bolts.
19. **VEHICLE SHOULD BE STOPPED AND INSPECTED FOR DAMAGE** after striking a foreign object and the damage should be repaired before restarting and operating the equipment. Stop immediately and check for damage or loose parts if mower should start vibrating.
20. **DISENGAGE BLADES BEFORE DRIVING ACROSS WALKS** or projecting objects.
21. **KEEP SAFETY DEVICES AND GUARDS IN PLACE.** If any of the safety switches become inoperable, have them repaired immediately.
22. **DO NOT STEP OR STAND ON THE MOWER HOUSING.** Step or stand only on the foot deck.
23. **WATCH OUT FOR TRAFFIC** near roadways and when crossing roads.
24. **DO NOT USE MOWER WHEN GRASS IS WET AND SLIPPERY.**
25. **MOW ONLY DURING DAYLIGHT.**

- 26. **THIS MACHINE IS NOT MEANT FOR HIGHWAY OR STREET USE.** It is not a recreational vehicle and it should not be operated as such.
- 27. **ALWAYS DISENGAGE THE MOWER BLADE CLUTCH** when transporting.

SAFETY INTERLOCK SYSTEMS

Your **Country Clipper** Zero Turning Radius Mower is equipped with switches interlocked for your safety.

ON JOYSTICK MODELS NEUTRAL IS WHEN THE JOYSTICK IS IN THE “**DOWN**” POSITION.

ON TWIN STICK MODELS NEUTRAL IS WHEN BOTH HANDLES ARE IN THE “**OUT**” POSITION.

- 1. The mower blades must be disengaged before engine will start.
- 2. The Control Lever(s) must be in the neutral position before the engine will start.
- 3. The engine will stop if the mower blade clutch is engaged when the operator leaves the driver’s seat.
- 4. The engine will stop if the Control Lever(s) are not in the neutral position when the operator leaves the driver’s seat.
- 5. The engine will stop if the brake is “**SET**” and the Control Lever(s) are not in the neutral position.
- 6. The engine will stop if the brake is “**SET**” and the mower blade clutch is engaged.

DO NOT OPERATE MOWER IF SAFETY SWITCHES ARE NOT OPERATING PROPERLY

START UP AND OPERATION

CHECKLIST BEFORE OPERATION

- 1. Make sure fuel tank is full. Use regular unleaded gasoline (see engine owner’s manual for more details).

WARNING

HANDLE GASOLINE WITH CARE -- IT IS HIGHLY FLAMMABLE. DO NOT SMOKE. ENGINE SHOULD BE OFF AND COOL. USE APPROVED GAS CONTAINER. NEVER FILL TANK INDOORS. WIPE UP ANY SPILLS. REPLACE CAP TIGHTLY.

- 2. Make sure dirt and foreign matter is kept out of gas tank. Use a clean funnel and gas can.
- 3. Do not mix oil with gasoline.
- 4. Do not use white, high test or premium gasoline. Do not use de-icers, carburetor cleaners, or other such additives.
- 5. Check the crankcase oil level. Make sure the engine is off. The mower should be parked on a level area. Do not overfill. (See your engine manual for more detailed instruction.)
- 6. Check the hydrostatic transmission oil level. (See “Maintenance” section of this manual.)
- 7. Check battery fluid level.
- 8. Inspect V-belts.
- 9. Check tire pressure:

Model	Front tires	Rear tires
All Models	12 psi	12 psi
- 10. Make sure underside of mower deck is free of grass.
- 11. Make sure mower blades are sharp and secured tightly.
- 12. Clean the air intake screen on the engine if necessary.
- 13. Perform any other maintenance as it becomes necessary. (See the “Maintenance” section of this manual.)

IMPORTANT: Before cutting grass, clutch must be broken-in as follows: With engine at full RPM engage deck until blades come to full speed and then disengage until blades come to a complete stop. Repeat 10 times to seat clutch properly.

CONTROL LOCATIONS

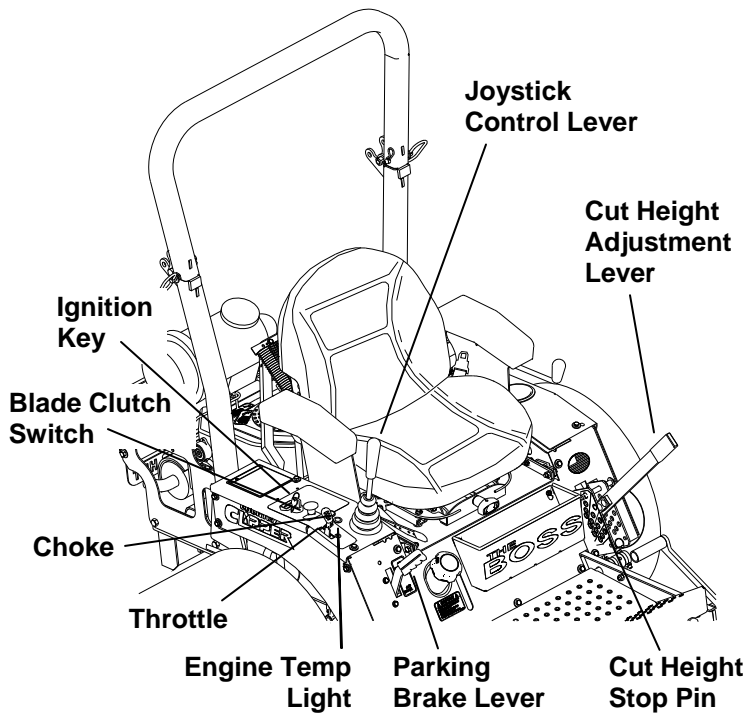

⚠ WARNING ⚠

AVOID INHALING EXHAUST FUMES -- CARBON MONOXIDE GAS IS COLORLESS AND ODORLESS, AND CAN CAUSE UNCONSCIOUSNESS, AND IS POTENTIALLY LETHAL. DO NOT RUN LAWN MOWER IN GARAGE OR OTHER CONFINED AREA.

OPERATION - JOYSTICK

1. MOVE JOYSTICK CONTROL LEVER TO neutral "DOWN" position.
2. SET PARKING BRAKE. Pull up to set.
3. DISENGAGE MOWER BLADE CLUTCH by moving clutch switch to "OFF" position.
4. PULL ENGINE CHOKE CONTROL to full position for cold starts.
5. SET ENGINE THROTTLE TO 1/2 THROTTLE.
6. TURN IGNITION KEY to "START" position and release to "RUN" as soon as engine starts. NOTE: Prolonged cranking will damage starter motor and shorten the battery life.

7. ADJUST ENGINE THROTTLE AND CHOKE for desired engine smoothness and speed.
NOTE: When mowing, always run engine at full throttle.
8. RELEASE PARKING BRAKE. Push brake lever down to release.

IMPORTANT: Until the operator is familiar with the **Country Clipper** Zero Turning Radius Mower, he/she should follow these recommendations: Disengage the mower blades. Go very slowly until thoroughly familiar with the machine. Keep away from fences, buildings, and other obstructions. Move the Joystick Control Lever smoothly and slowly. Practice until operation is smooth and efficient.

9. TO DRIVE: Move the Joystick Control Lever to the "UP" position. Move the Joystick Control Lever forward to move forward. Increasing forward movement of the Joystick Control Lever will increase the speed of travel. To reverse the direction, pull the Joystick Control Lever slightly back. To turn, move the Joystick Control Lever toward the direction you want to turn.. To turn on a zero radius axis, go slowly and move the Joystick Control Lever to the side you wish to turn and slightly to the rear at the same time.
 10. Make sure mower blades are sharp and secured tightly.
 11. Clean the air intake screen on the engine if necessary.
 12. Perform any other maintenance as it becomes necessary. (See the "Maintenance" section of this manual.)
- IMPORTANT:** Before cutting grass, clutch must be broken-in as follows: With engine at full RPM engage deck until blades come to full speed and then disengage until blades come to a complete stop. Repeat 10 times to seat clutch properly.
13. If Engine temp light comes on, turn mower off and check coolant level. If coolant level is full, take mower in for service. Engine temp light is only on Liquid cooled engines.

CONTROL LOCATIONS

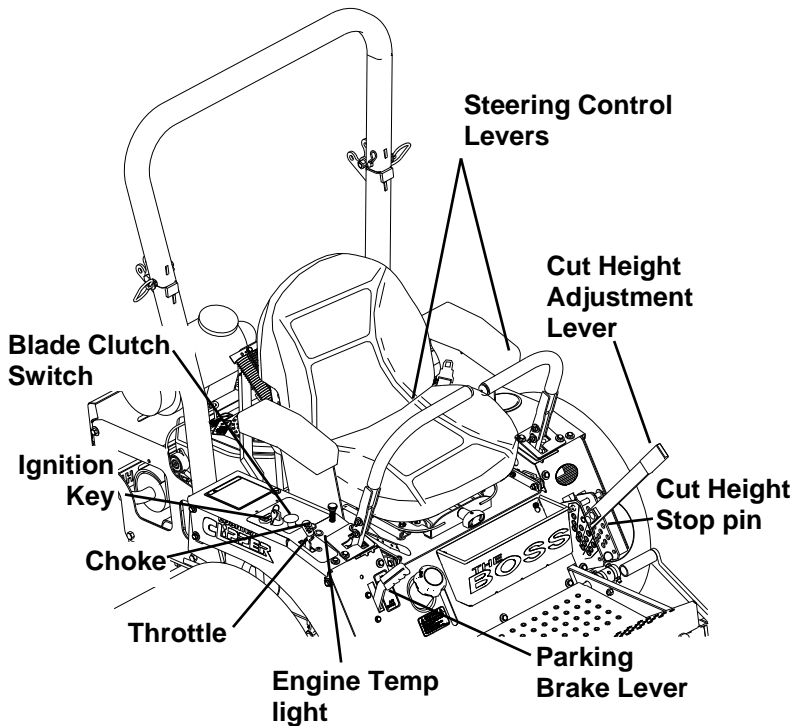

WARNING

AVOID INHALING EXHAUST FUMES -- CARBON MONOXIDE GAS IS COLORLESS AND ODORLESS, AND CAN CAUSE UNCONSCIOUSNESS, AND IS POTENTIALLY LETHAL. DO NOT RUN LAWN MOWER IN GARAGE OR OTHER CONFINED AREA.

OPERATION – DUAL LEVER

1. MOVE STEERING CONTROL LEVERS TO neutral "OUT" position.
2. SET PARKING BRAKE. Pull up to set.
3. DISENGAGE MOWER BLADE CLUTCH by moving clutch switch to "OFF" position.
4. PULL ENGINE CHOKE CONTROL to full position for cold starts (on non-fuel injected models).
5. SET ENGINE THROTTLE TO 1/2 THROTTLE.
6. TURN IGNITION KEY to "START" position and release to "RUN" as soon as engine starts. NOTE: Prolonged cranking will damage starter motor and shorten the battery life.

7. ADJUST ENGINE THROTTLE AND CHOKE for desired engine smoothness and speed.

NOTE: When mowing, always run engine at full throttle.

8. RELEASE PARKING BRAKE. Push brake lever down to release.

IMPORTANT: Until the operator is familiar with the Zero Turning Radius Mower, he/she should follow these recommendations: Disengage the mower blades. Go very slowly until thoroughly familiar with the machine. Keep away from fences, buildings, and other obstructions. Move the Steering Control Levers smoothly and slowly. Practice until operation is smooth and efficient.

9. TO DRIVE: Move the Steering Control Levers to the "IN" position. Move the Steering Control Levers forward to move forward. Increasing forward movement of the Steering Control Levers will increase the speed of travel. To reverse the direction, pull the Steering Control Levers slightly back. To turn, move one Steering Control Lever slightly ahead of the other. To turn on a zero radius axis, go slowly and move one Steering Control Lever forward and one Steering Control Lever rearward. (For a right hand turn the left hand Steering Control Lever will be ahead of the right hand Steering Control. For a left hand turn the right hand Steering control will be ahead of the left hand Steering Control.)



CAUTION



FOR SMOOTH, SAFE OPERATION, MOVE THE CONTROL LEVER(S) IN A GENTLE, SLOW MOTION. NEVER PULL OR PUSH THE CONTROL LEVER(S) RAPIDLY, ESPECIALLY ON GRADES.

10. BRAKING: To brake mower, gently move the Control Lever(s) in the direction opposite to travel. If the parking brake is engaged with the Joystick Control Lever in the "UP" position or the Twin Sticks (if equipped) in the "IN" position the engine will stop.
11. If Engine temp light comes on, turn mower off and check coolant level. If coolant level is full, take mower in for service. Engine temp light is only on Liquid cooled engines.

12. **CUTTING HEIGHT ADJUSTMENT:**
With the Cut Height Adjustment Lever latched into the top cut height latch, insert Cut Height Stop Pin to desired cutting height. Pull Cut Height Adjustment Lever rearward and then to the left to clear top cut height latch. Lower Cut Height Adjustment Lever until it rests on Cut Height Stop Pin.

13. **ENGAGE MOWER BLADE CLUTCH:**
Set the Blade Clutch Switch to the "ON" position. The engine will not start if the blade clutch is engaged. If the operator is not in the seat, the engine will stop if the clutch is engaged.

CAUTION

AVOID HILLS AND SLOPES. USE EXTREME CAUTION WHEN MOWING UP OR DOWN SLOPES. NEVER MOW ACROSS THE FACE OF A SLOPE. IF A SLOPE MUST BE ASCENDED, BACK UP THE SLOPE; DRIVE FORWARD WHEN DESCENDING.

14. **TO STOP:**
- A. Move Joystick Control Lever to neutral position and then to the "DOWN" position.
 - A2. Move the Twinstick handles to the neutral position and then push both handles out as far as they will go.
 - B. Disengage the mower blade clutch by moving the clutch to the "OFF" position.
 - C. Set the parking brake.
 - D. Slow engine speed with throttle to slowest position.
 - E. Turn ignition key to "OFF" (left) position.
 - F. Remove the key and wait for all movement and all sound to cease before dismounting.

CAUTION

WHEN LEAVING THE MOWER UNATTENDED, ALWAYS REMOVE THE KEY AND SET THE PARKING BRAKE, EVEN IF JUST FOR A FEW MOMENTS. HELP PROTECT CHILDREN AND OTHER UNAUTHORIZED PERSONS FROM ACCIDENTS.

15. **TO FREE WHEEL MACHINE:**
Unscrew the bypass valve (½ turn counter clockwise) found on the left front of the right pump and the valve on the right front of the left pump. Remove fan shroud and use a 5/8" wrench to turn bypass valve ½" turn.

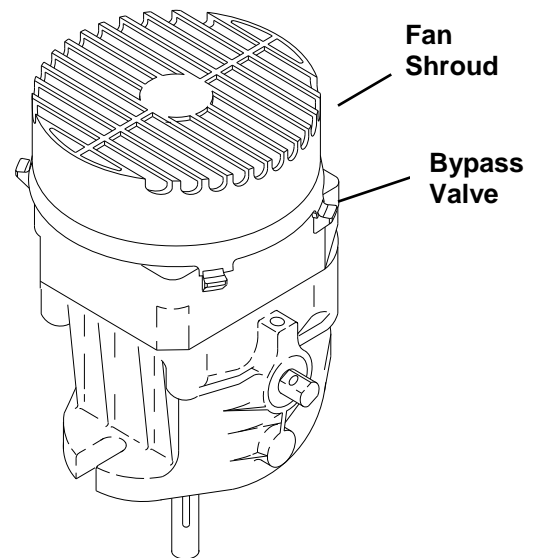

CAUTION

NEVER OPERATE MOWER WITHOUT DISCHARGE CHUTE

MOWING RECOMMENDATIONS

1. Keep mower blades sharp.
2. Make sure deck and discharge are clean.
3. When mowing tall grass, make two passes, mowing off 1/2 of the desired



- cut on the first pass, and then the desired height the second pass. Check for hidden dangers first.
4. Go slowly for trimming.
5. Always cut grass with the engine at full throttle speed. This "ENGINE" speed allows the cutting blades to operate at optimum cutting speed. Control "GROUND" speed with the Control Lever(s).
6. Vary ground speed to suit conditions (i.e. go slower in tall thick grass, on hills, wet conditions, etc.)

MAINTENANCE



CAUTION



**BEFORE PERFORMING ANY MAINTENANCE, TURN OFF ENGINE
REMOVE KEY AND DISCONNECT SPARK PLUGS. USE EXTREME CARE WHEN WORKING ON
MACHINERY. DO NOT WEAR WATCHES OR JEWELRY. DO NOT WEAR LOOSE FITTING
CLOTHES, AND OBSERVE ALL COMMON SAFETY PRACTICES WITH TOOLS.**

MAINTENANCE SCHEDULE

<i>SERVICE</i>	<i>WHEN</i>
Check crankcase oil level -----	before each use
Clean grass from Hydrostat Oil Cooler-----	before each use
Check air intake screen -----	after each use
Clean grass under deck -----	after each use
Check tire pressure -----	every 10 hours
Check battery fluid -----	every 10 hours
Sharpen mower blades -----	every 10 hours
Clean air filter pre-cleaner element -----	every 25 hours
Check Hydrostatic Transmission fluid -----	every 25 hours
Check drive belts -----	every 50 hours (20 hours break-in)
Service Air Cleaner Filter Element -----	every 100 hours
Change engine crankcase oil -----	100 hours
oil filter -----	200 hours
Change Hydrostat oil and oil filter -----	every 500 hours (100 hours break-in)
Replace air filter element -----	annually or 500 hours
Check spark plugs -----	annually or 500 hours
Service battery -----	annually or 500 hours

Replace decals when illegible. Write factory for free replacement.

MAINTENANCE INSTRUCTIONS

1. ENGINE:

For complete maintenance and operating information for your engine, please refer to your engine operating and maintenance instructions furnished by the engine manufacturer and included in your **Country Clipper Zero Turning Radius Mower** information packet.

NOTE: Air intake screen must be kept clean. If plugged, engine may be seriously damaged by over heating.

2. BATTERY:

CAUTION

BATTERY ELECTROLYTE IS A POISONOUS AND CORROSIVE SULFURIC ACID SOLUTION. AVOID SPILLING ON SKIN, EYES, AND CLOTHING.

Keep the electrolyte level above the plates in each cell by adding distilled water as it becomes necessary. Add water just before operating the mower to mix the water with the solution. Be careful not to overfill the battery -- the electrolyte solution is corrosive and can cause damage to surrounding metal parts if it should spill. When taking the battery out of the mower for servicing, make sure to connect the cables to the battery exactly as they were prior to removal. Always disconnect the ground (-) wire first and always reconnect the ground (-) wire last.

Keep the battery clean. Remove the corrosion around the battery terminals by applying a solution of one part baking soda to four parts water. Coat all exposed terminal surfaces with a light layer of grease or petroleum jelly to prevent corrosion.

NOTE: At temperatures below 32 degrees F (0 degrees C) the full charge state must be maintained to prevent cell electrolyte from freezing and causing permanent battery damage.

3. TIRES:

Correct tire pressure is essential for efficient operation of the mower. Check tire pressure as requested in the maintenance schedule. Inflate tires to the pressures listed below:

Model	Front tires	Rear tires
All Models	12 psi	12 psi

Lug nuts should be checked regularly for tightness.

4. MOWER BLADES:

Check sharpness of mower blades after every 10 hours of operation. To sharpen blades proceed as follows:

CAUTION

STOP ENGINE, REMOVE IGNITION KEY AND SPARK PLUGS FOR SAFETY.

- A. Remove bolt and blade washer mounting blade on shaft. Remove blade.
- B. Blades should be discarded when worn excessively.

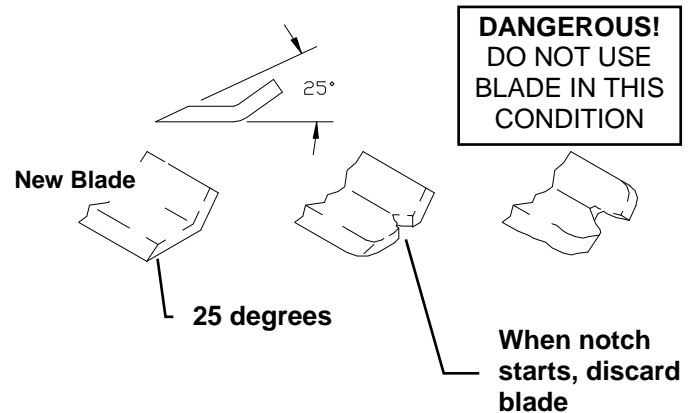

- C. Sharpen blades with a hand file, electric grinder or blade sharpener. Wear gloves and eye protection when sharpening. Grind blade at original 25 degree bevel.

D. Check balance of blade by positioning the blade on a nail or blade balance pedestal. Grind the blade on the end that is heavier until both sides balance.

E. Install blade, blade washer, and bolt. Make sure to tighten bolt to 100 ft-lbs.

5. V-BELTS:

All belts should be checked every 50 hours. Replace any belts found to be in poor condition. All belts are equipped with spring loaded belt tighteners and do not require tightening adjustments.

6. LUBRICATION:

A. Engine: Follow engine manufacturer's recommendation.

B. Hydrostatic Transmission & Filter: Follow instructions listed below.

DIRT OR WATER IN OIL CAN RUIN THE HYDROSTATIC TRANSMISSIONS

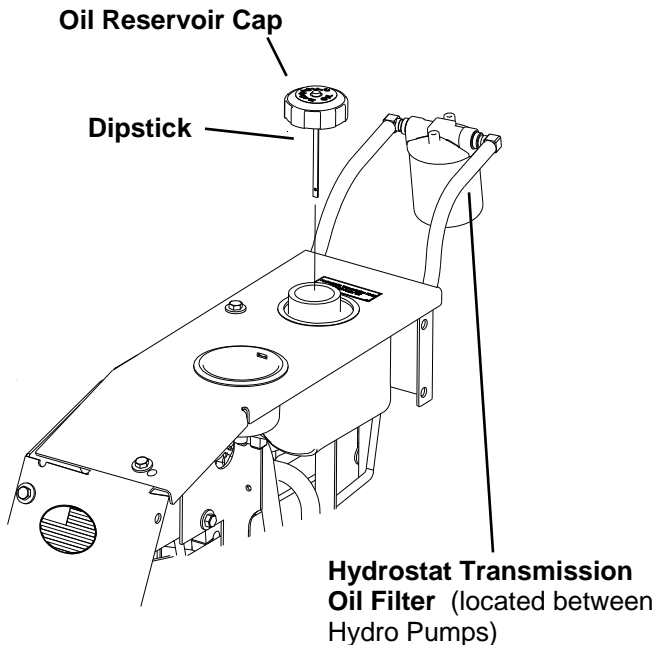

Check the oil level in hydrostatic transmission oil reservoir after every 25 hours of usage. Clean the oil reservoir cap and the area around it prior to removal. Check the oil level on the dipstick. The proper oil level should register between the marked hole on the

dipstick and the end of the dipstick. Replenish as needed with 20W-50 Motor Oil. **DO NOT OVER FILL.** When checking the oil level, be very careful to keep the reservoir clean

Change the oil in the reservoir and hydrostatic transmission filter after the first 100 hours of use, then every 500 hours after that. Remove the filter and be sure all oil has drained from the reservoir. Replace with new filter (P/N H-2026) and 20W-50 Motor Oil.

7. PARKING BRAKE ADJUSTMENT:

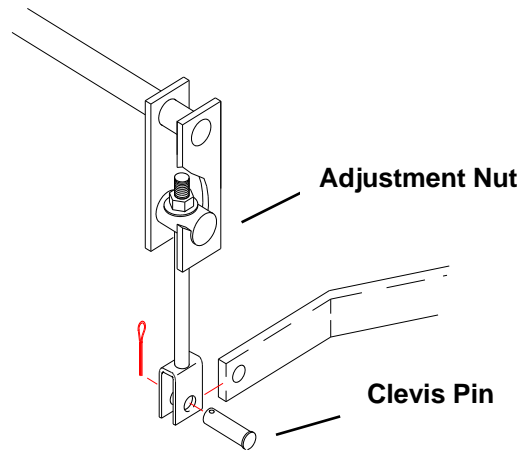

- A. Remove the clevis pin from the left brake.
- B. Tighten the adjustment nut on the right brake until it takes 28 pounds of pull to lock the brake handle over center.
- C. Install the clevis pin back on the left brake.
- D. Tighten the adjustment nut on the left brake until it takes 56 pounds to lock the brake handle over center, with both brakes connected.

8. SEAT HOLD DOWN LATCH:

To release the seat hold down latch, lift the latch bar while flipping the seat up and forward.

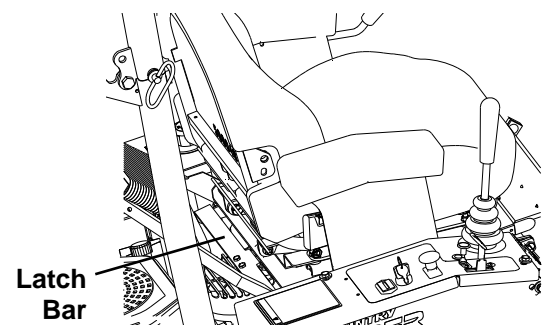

9. TWINSTICK CONTROL LEVER FORWARD ADJUSTMENT:

- A.** Remove the fender skirts from each side of the machine.
- B.** Block up the unit so that the Drive Wheels are off the ground.
- C.** Loosen the locknuts on the turnbuckle on the upper linkage on each side.
- D.** Push both control levers forward until they hit the stops on the control arms.
- E.** Bungee cord the arm at this position and lengthen the upper linkage rods until they bottom out the transmissions.
- F.** Back off the turnbuckles $\frac{1}{2}$ turn and lock in place with the locknuts.

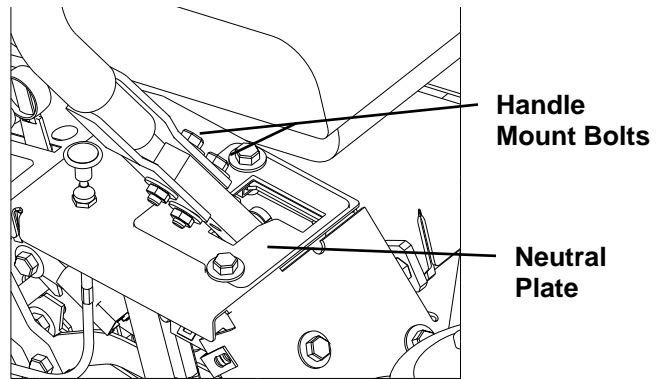

11. TWINSTICK CONTROL LEVER FORWARD TRACKING:

In a large open area, actuate the control levers into the full forward position. If the mower veers in either direction left or right some adjustment is necessary. If the mower veers to the right, then the left transmission needs to be slowed down. If the mower veers to the left, then the right transmission needs to be slowed down.

- A.** Stop the machine and shut off the engine.
- B.** Slightly loosen the nuts around the turnbuckle on the faster side. Lengthen the linkage rod by $\frac{1}{4}$ turn increments, retighten and retest, until the mower tracks straight.
- C.** Once the tracking is to the operator's liking, completely tighten the nuts on the turnbuckle. Recheck and adjust the Neutral Plate, if required.
- D.** Reinstall the side plates and tighten all bolts.
- E.** If the forward tracking still requires "fine tuning", use the on-the-fly fine adjustment knob on top of the fender cap, next to the Control lever. Make small adjustments to full forward as needed.

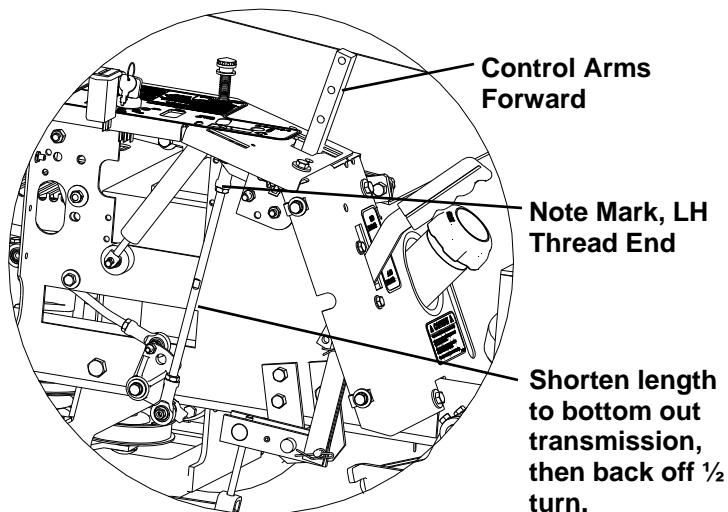

10. TWINSTICK CONTROL LEVER NEUTRAL ADJUSTMENT:

- A.** Loosen the bolts holding the Neutral Plate.
- B.** Pull back the control lever until the wheel spin is zero.
- C.** Tilt the Control lever outward, using the lever, position and tighten the bolts holding the Neutral Plates.

12. TO ADJUST "IN" OR OPERATING POSITION OF THE TWINSTICK STEERING CONTROL LEVERS:

If the Control levers are too close in the center or the Control levers drag on the Neutral Plate, adjust as follows.

- A.** Tilt the Control lever outward, loosen the locknut and adjust the

bolt until the gap between the handles is correct or the Control lever does not rub the Neutral Plates.

- B. Tighten the locknut after the adjustment is made.

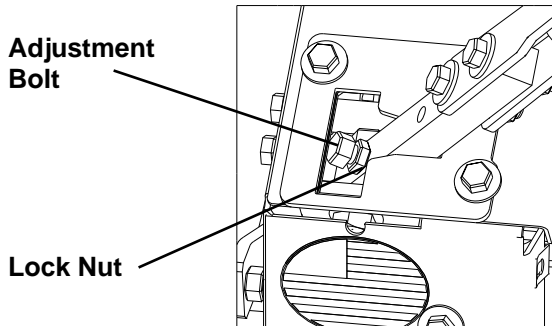

NOTE: To prevent damage to Control Linkages the Control Lever must always hit on the Stop Screws. Never adjust Stops out so that the Control Lever “bottoms” out on other parts of the linkage.

13. ALIGNING THE HANDLES:

Once forward tracking and neutral are set, the handle position may be adjusted for operator comfort and alignment. Loosening the handle mount bolts, move the levers into the desired position and re-tighten the mounting bolts securely.

14. JOYSTICK CONTROL LEVER NEUTRAL ADJUSTMENT:

With the engine running, if the machine travels in either direction when the Joystick Control Lever is in the neutral “DOWN” position, stop the engine, elevate the rear wheels clear of the ground and adjust as follows:

- A. Remove the right hand fender skirt exposing the Joystick Control Lever Assembly.
- B. Start the engine.
- C. Run engine at fast idle with Joystick Control Lever in the “DOWN” position.
- D. Loosen the locknuts tightened against the rod end ball joints on the Upper Linkage Assembly that corresponds to the wheel that is

turning. Note: One of these is a left hand nut and will have to be turned backwards.

- E. Adjust the Neutral Position by turning the rod in the upper linkage until the wheel stops turning.
- F. Retighten the locknuts on the upper linkage assembly and check to make sure the drive wheel is still not turning.
- G. Repeat steps B through F for other side, if needed.
- H. Shut off engine before removing from blocks. Replace fender skirt.

15. JOYSTICK ADJUSTMENT CONTROL LEVER DETENT:

If the Joystick Control Lever does not lock in the “UP” position, turn the detent adjustment screw clockwise until a desirable locking action is obtained. If the Joystick control Lever is hard to slide up and down, turn the detent adjustment screw counter-clockwise until a desirable sliding action is obtained.

16. JOYSTICK CONTROL LEVER SENSITIVITY ADJUSTMENT:

To change the sideways turning response, adjust as follows:

- A. Remove the right hand fender skirt exposing the Joystick Control Lever assembly.
- B. Remove the cross bolt, nut, and spacers
- C. Reassemble the spacers as desired. (2) spacers between the rod end ball joints and the joystick pivot shaft will quicken the side to side response, (1) spacer slows the response.

NOTE: It is important that there is at least one spacer on each side of the rod end ball joints to prevent damage. Also the small diameter of the spacer must point towards the rod end ball joint.

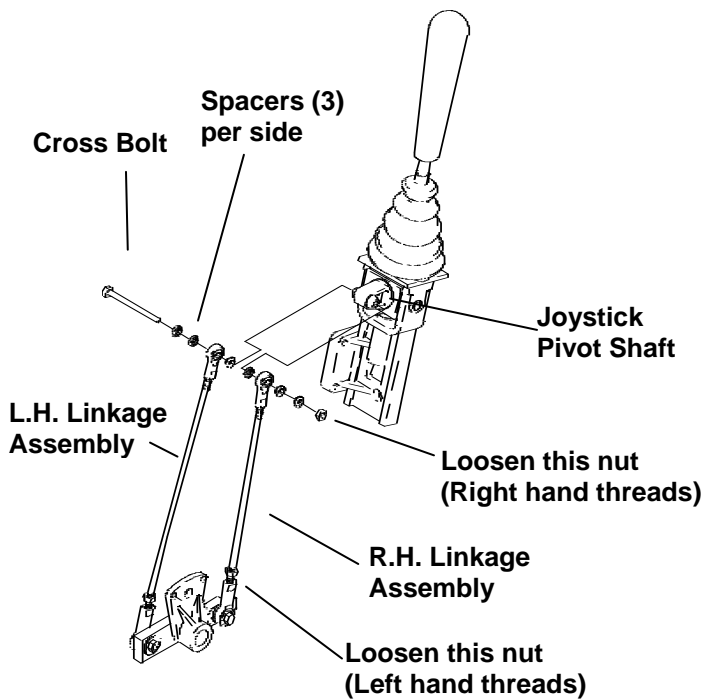

17. ADJUSTING FOR STRAIGHT FORWARD TRACKING:

In a large open area, actuate the Joystick Control lever into the full forward position. If the mower veers in either direction left or right some adjustment is necessary.

- A. If the mower veers to the right, then the right hydrostat needs to be sped up. If the mower veers to the left, then the left hydrostat needs to be sped up.
- B. Stop the machine and shut of the engine.
- C. Slightly loosen the bolt at the lower end of the upper linkage assembly on the side that is slower. Using a 1/8" allen wrench turn the setscrew ¼ turn in. It may take several test drives to get the mower to track straight forward.
- D. Once the tracking is to the operators liking, completely tighten the bolt on the control linkage assembly that was loosened earlier.
- E. Recheck to make sure neutral adjustment has not been effected.

See picture below:

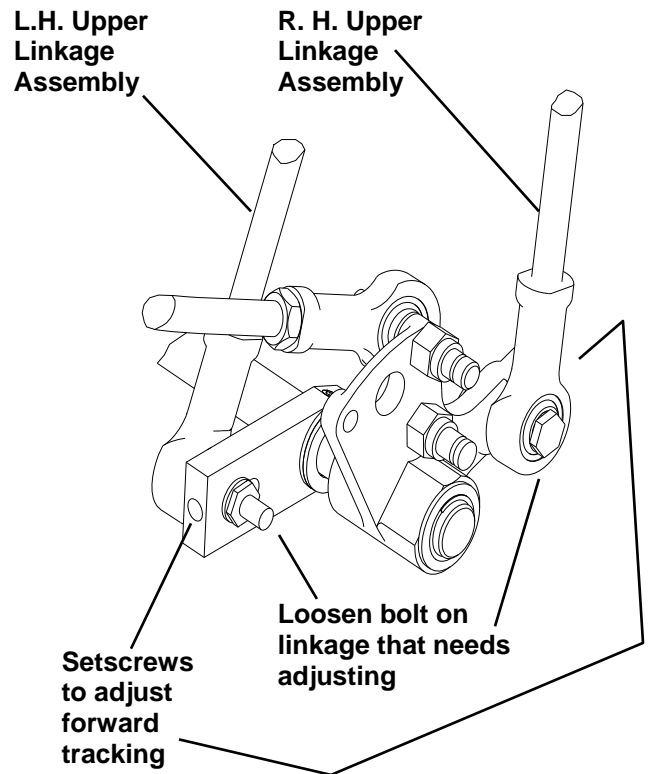

18. JOYSTICK CONTROL LEVER SHIFTING FORCE ADJUSTMENT:

To change the amount of force required to shift the joystick control lever adjust as follows:

- A. **Heavier Force to Move Joystick Control Lever:** Loosen nuts on rear Damper mounting studs. (Both sides) Move rear of dampers down in slots. Re-tighten nut.
- B. **Lighter Force to Shift Joystick Control Lever:** Loosen nuts on rear Damper mounting studs. (Both sides) Move rear of dampers up in slot. Re-tighten nut.

See picture below:

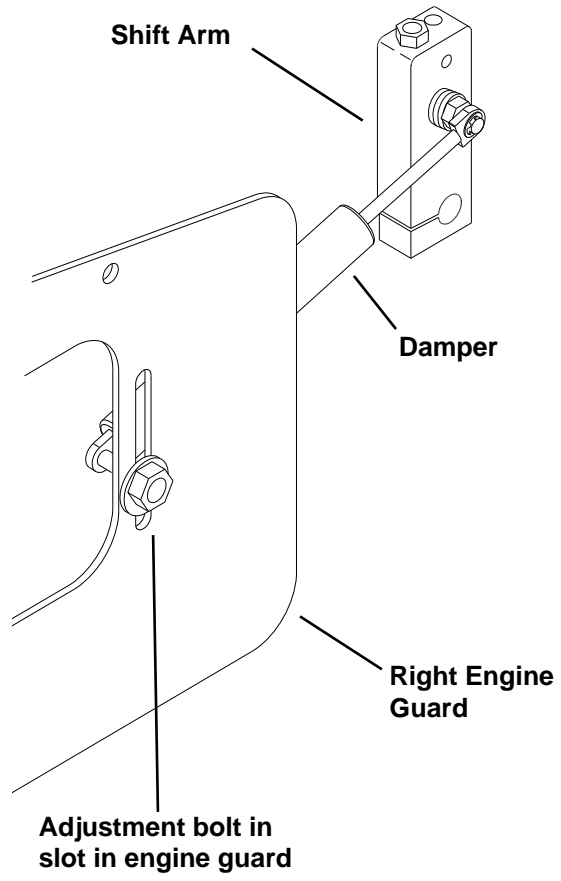

**DRIVE BELT CONFIGURATION
VIEWED FROM FLOOR LOOKING UP**

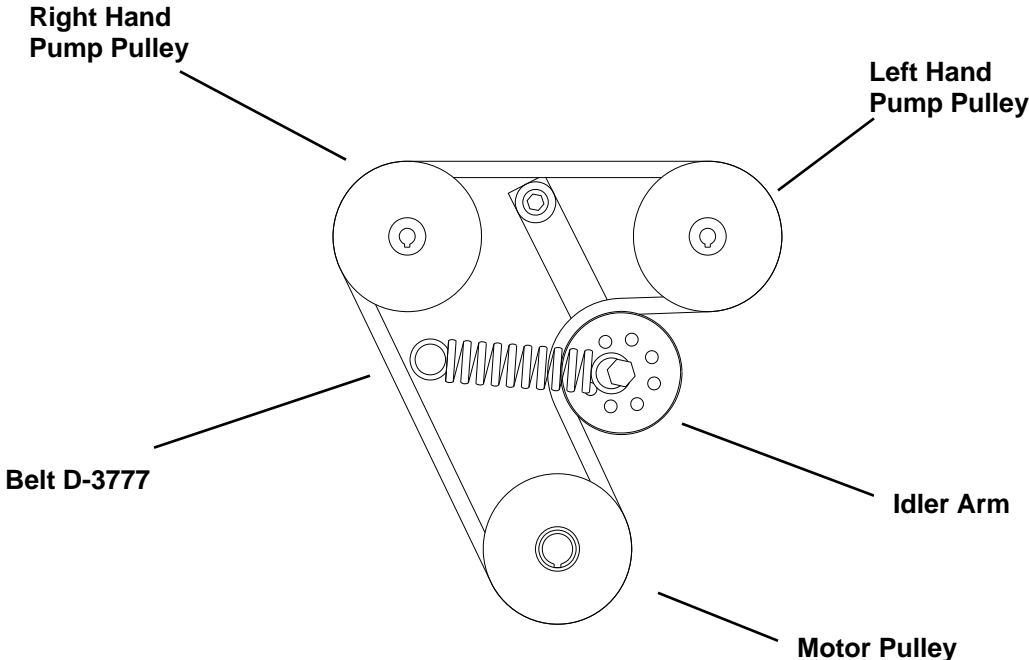

QRS LATCH CONFIGURATION

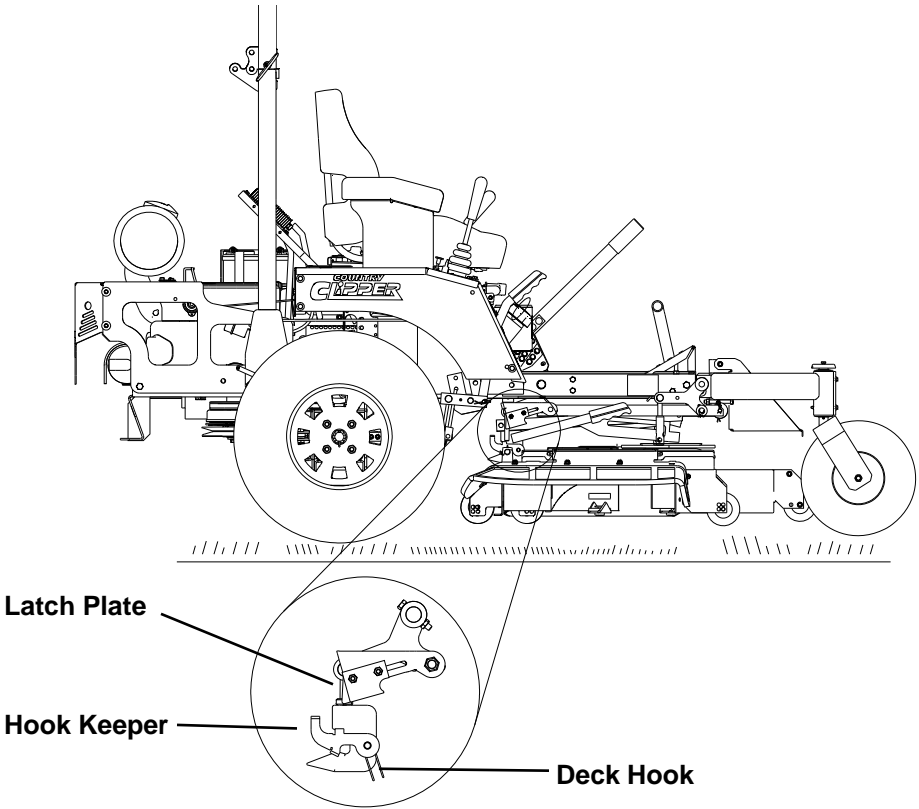

DECK BELT ROUTING

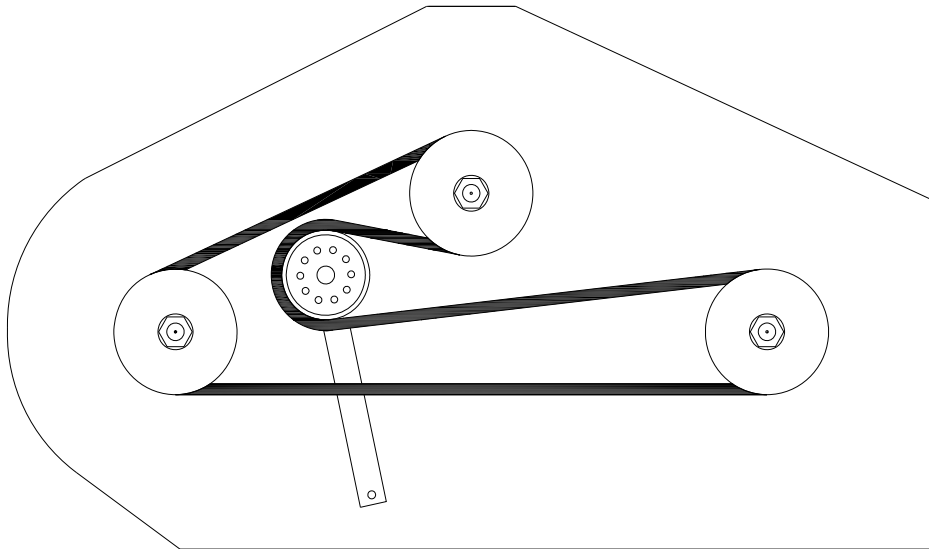

ENGINE TO DECK BELT ROUTING

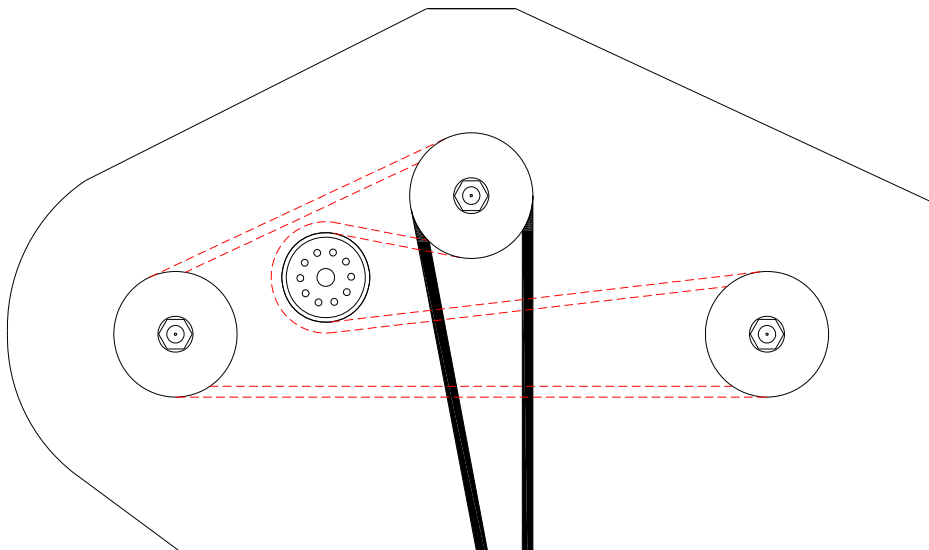

	<u>DECK BELT</u>		
	60"	D-3796	B-124
	72"	D-3797	B-142
	<u>ENGINE TO DECK BELT</u>		
	60"	D-3809	B-120
	72"	D-3796	B-124

Spring ——— "V" PULLEY

CLUTCH

RAISING AND LOWERING THE DECK FOR SERVICING

1. RAISING THE DECK:

- A. Remove cut height adjustment pin and completely lower the cut height adjustment lever. Re-insert the cut height adjustment pin into the 3-1/2" cut height position (this will lock the cut height adjustment lever into the lowest position).
- B. Release engine to deck belt tightener located behind the left rear tire. (see illustration page 19) Flip up the foot deck to allow access to the engine to deck belt. Roll the belt off the center spindle. Hook the belt onto the bolt protruding out of the top of the foot deck support angle.
- C. On the right side of the mower, lift and hold up on the hook keeper. Lift up on the release handle to disconnect the back of the deck. The latch plate should catch and hold the release handle rod in place. (To adjust the latch plate, see Page 20.)
- D. Position the front caster wheels so they are away from the deck (such as the tractor would be traveling in reverse).

- E. Lift the nose of the deck until the deck is standing vertical (lifting can be made easier if someone stands on the rear bumper of the tractor). **IMPORTANT NOTE: MAKE SURE THAT THE DECK IS LIFTED FAR ENOUGH TO GO COMPLETELY "OVER-CENTER"**. This will prevent the deck from falling down when servicing the underside of the mower deck.

2. LOWERING THE DECK:

- A. Push the bottom (back) of the deck towards the rear of the tractor. Lower the deck until it rests on the ground.
- B. Lift up on the latch plate to release the release handle rod. Push down on the release handle until deck hooks lock into place.
- C. Re-install the Engine to Deck Drive belt onto ALL of the pulleys, including the clutch. **Insure that the Engine to Deck Drive Belt is properly routed onto all of the pulleys and idlers in the drive train.**
- D. Carefully rotate the Deck Belt Tension Latch to re-tension the Engine to Deck Drive Belt.

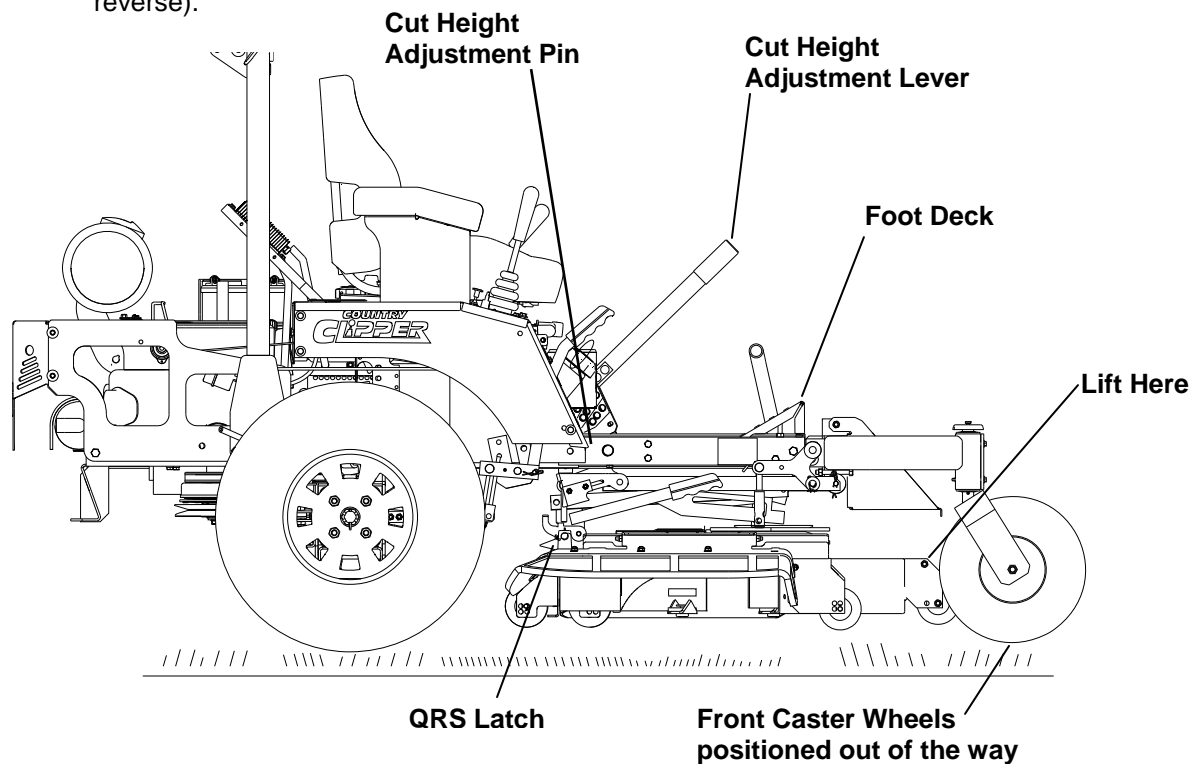

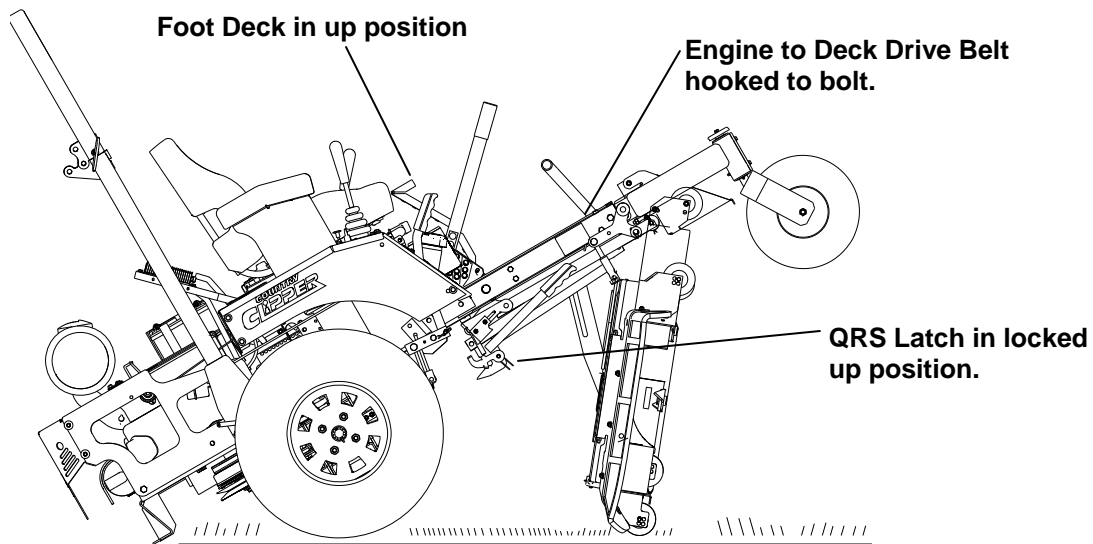

LEVELING THE DECK

1. Move the tractor to a hard, level surface (i.e. concrete or blacktop).
2. Set the tire pressure on all four tires to 12 psi.
3. Rotate the blade you are going to measure to run parallel with tractor frame, front to back.
4. Set the Deck Cut Height Lever to the 4' cutting position.
5. Loosen the Deck Hanger Bolt Jam Nuts.
6. Adjust the Front Left Hand Deck Hanger Bolt until the front edge of the Left Hand Blade is Approximately 4" from ground.
7. Adjust the Front Right Hand Deck Hanger Bolt until the front edge of the Right Hand Blade is within 1/8" of the Front Left hand Blade measurement. NOTE: "On 72" Decks" If the Front Right Hand blade measurement can not be obtained it will be necessary to shorten or lengthen the Adjustable Drag Bar Link on the right hand side of the deck suspension. Lengthening the Adjustable Draglink lowers the front end of the Right Hand blade and shortening the Adjustable Drag Bar Link raises the front of the Right Hand blade.
8. Adjust both Rear Deck Hanger Bolts until the back of the blades are 1/8" to 1/4" higher from the ground than the front of the blades. Inspect that the deck is solidly hanging on all four Deck hanger Bolts. Adjust rear Deck Hanger Bolts accordingly.
9. Inspect all of the above measurements. Tighten all four Deck Hanger Bolts Jam Nuts.

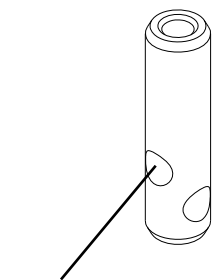
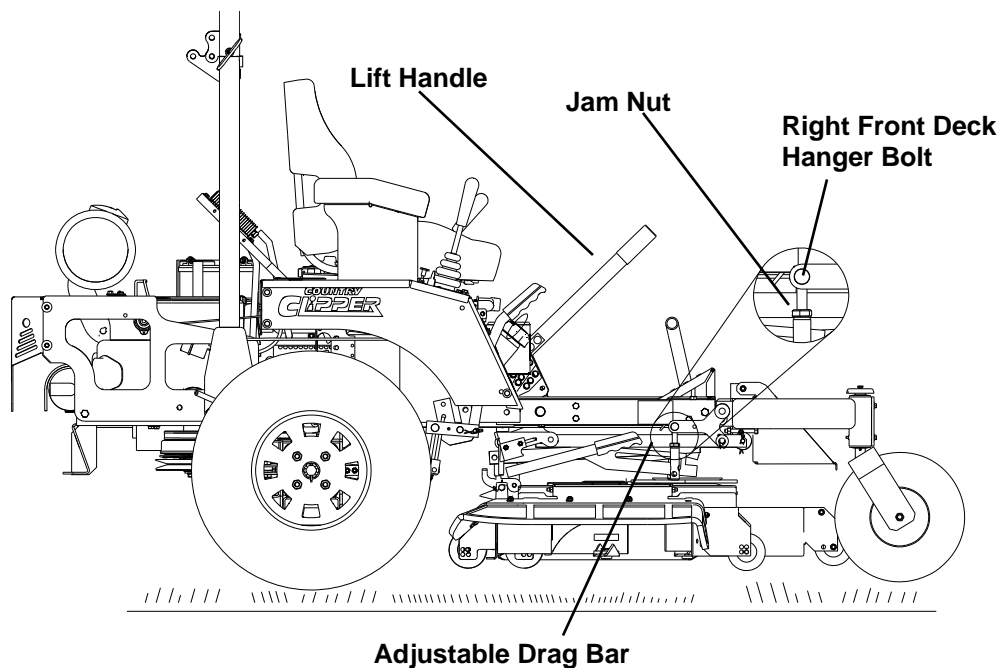

Note: If you run out of threads during the adjustment process, remount the deck mounting in this upper hole.
IF ATTEMPTING TO ADJUST DECK HIGHER THAN DESIGN SPECIFICATIONS, DECK DRIVE FAILURE CAN OCCUR.

ADJUSTING THE LATCH PLATE

1. Level the deck before proceeding to adjust the latch plate. (Follow instructions on previous page.) Pin the deck in the lowest position before proceeding to adjust the latch plate.
2. Lift up on the hook keeper, while pulling up on the release handle. This will disconnect the rear of the deck.
3. Loosen nuts on the adjustment of the latch plate using a 7/16 wrench. Pull up on the release handle as far as it will allow. Slide adjustment back or forward to where the latch plate will catch the release handle rod at its highest location. Tighten nuts back.
4. Lift up on latch plate and push down on the release handle to lock deck hooks in place.
5. Double check the latch plate adjustment by releasing the deck hangers and pulling up on the release handle. If the latch plate catches the release handle rod, no further adjustment needs to be made. If it does not, follow steps 3-5, as needed.

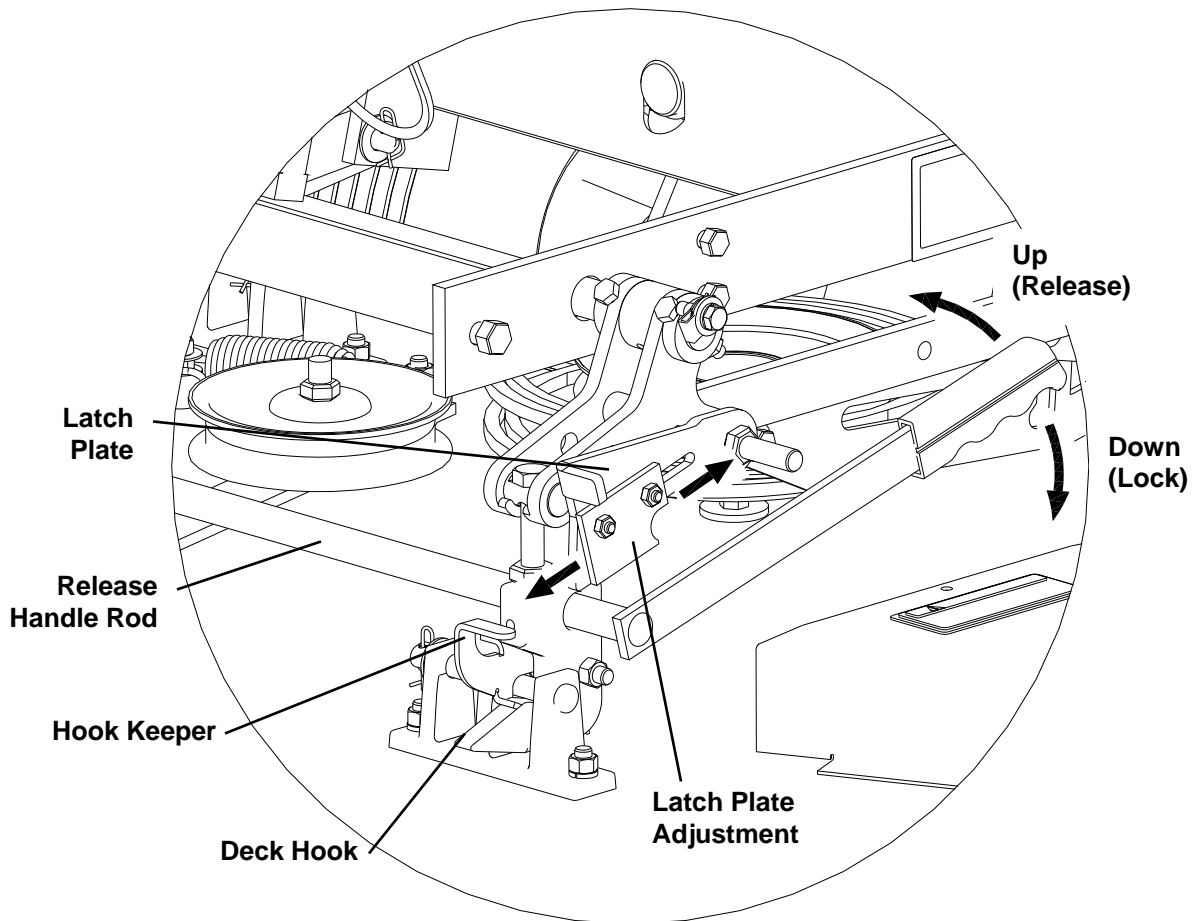

DECK FLIP JACK ASSEMBLY AND OPERATION

1. Back the mower up so the front caster wheels are rotated forward.
Turn off lawn mower and set brakes. Remove cut/height adjust pin and lower deck lift handle to lowest position. Reinsert cut/height adjust pin above deck lift handle.
2. Release engine to deck belt tightener located behind the left rear tire.
3. Flip up the foot deck to allow access to the engine to deck drive belt, remove the engine to deck drive belt off the center spindle. Hook the engine to deck drive belt onto the bolt protruding out of the top of the foot deck support angle. Flip the step up out of the way. Unhook rear of deck by lifting the QRS handle.
4. Release bungee cord from end of jack. Rotate handle up into cranking position. Turn handle clockwise until the ball end of the jack enters the "V" on the bottom arm. Continue turning until the rear wheel is approximately 8 inches off of the ground.
5. Move to same rear wheel and push it back to the ground bringing the front of the deck off of the ground. Continue to turn the handle bringing the deck up into position to work on it. (Do not over turn crank! Damage may occur.)
6. To lower deck, reverse the process.

Note: When storing jack, the crank handle must be folded "closed" and secured to the drag bar with a bungee cord.

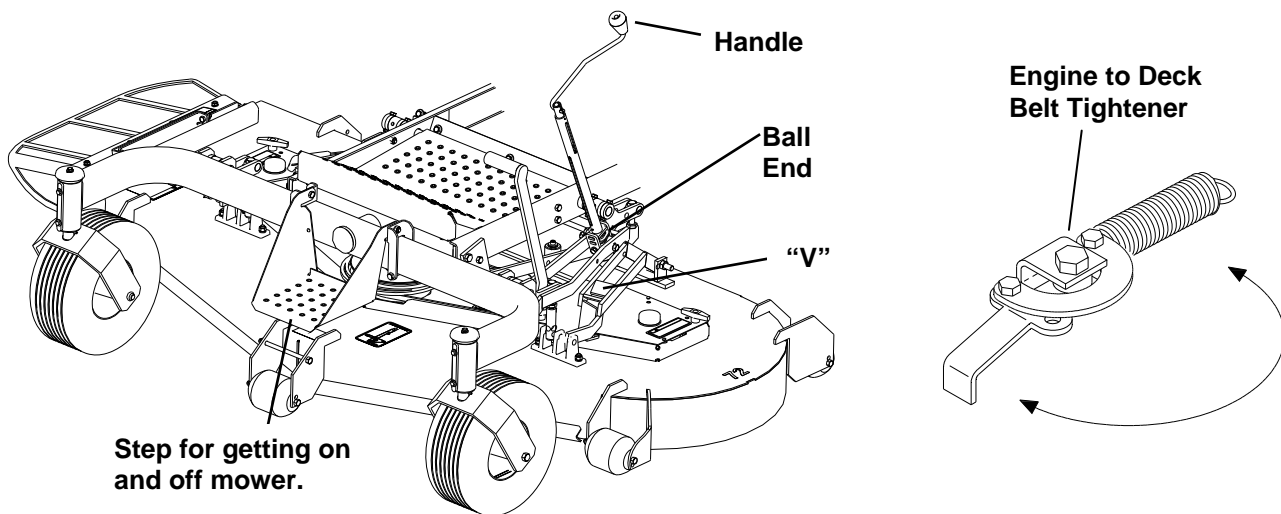

CAUTION



CAUTION: KEEP FEET CLEAR FROM EDGE OF DECK WHEN LOWERING DECK FROM STAND-UP TO OPERATION POSITION.



CAUTION



DECK FLIP TOOL MUST BE USED TO POSITION 72" MOWER DECKS TO THE STAND-UP SERVICE POSITION. ATTEMPTING TO MANUALLY RAISE 72" MOWER DECKS TO THE STAND-UP POSITION CAN RESULT IN SEVERE PERSONAL INJURY.

TROUBLESHOOTING CHECKLIST

1. ENGINE WON'T TURN OVER:
 - Mower blades engaged ----- disengage blades
 - Drive not in neutral --- **move Joystick Control Lever to neutral "DOWN" position**
move Twinstick Control Levers to neutral "OUT" position
 - Blown fuse ----- replace fuse
 - Dead battery ----- charge or replace
 - Solenoid ----- consult dealer
 - Ignition switch ----- consult dealer
 - Starter ----- consult dealer

2. ENGINE WILL TURN OVER BUT WON'T START:
 - No gas ----- refuel
 - clean or replace fuel filters
 - Over or under choked ----- adjust choke
 - Spark plug not firing ----- check spark plug
----- condition and reset gap*
 - Carburetor maladjustment ----- reset carburetor adjustment*
 - Ignition switch ----- consult dealer

3. HARD TO START ENGINE:
 - Fuel line clogged ----- clean fuel line and check fuel filter
 - Faulty fuel pump ----- consult dealer
 - Spark plug wire loose or grounded ----- check spark plug wires
 - Spark plug(s) faulty or improperly gapped ----- check spark plug
----- condition and reset gap*
 - Electronic ignition defective ----- consult dealer
 - Dirty or maladjusted carburetor ----- readjust carburetor*
----- consult dealer for carburetor service

4. ENGINE STARTS BUT CUTS OUT:
 - Water in gasoline ----- drain old gasoline and replace with new gasoline
----- clean carburetor bowl
 - Clogged fuel line ----- check fuel filter
----- clean fuel line
 - Vent in fuel cap plugged ----- check vent
 - Faulty fuel pump ----- consult dealer
 - Maladjusted carburetor ----- readjust carburetor*
 - Engine dies when: **Joystick Control Lever is pulled "UP"** ----- parking brake set
Twinstick Control levers are pulled "IN" ----- release brake

5. ENGINE KNOCKS:
 - Low oil level ----- check and add oil
 - Ignition timing off ----- consult dealer
 - Fuel octane too low ----- drain and replace with
----- higher octane gasoline
 - Over heated engine ----- shut off engine and allow to cool

* See engine manual for engine adjustments.

- 6. ENGINE SOMETIMES SKIPS AT HIGHER SPEEDS:**
 Incorrect Ignition Timing ----- consult dealer
 Carburetor maladjusted ----- readjust carburetor
 Faulty spark plugs ----- check spark plug
 condition and reset gap*
 Bouncing off seat safety switch ----- slow down on rough terrain
- 7. ENGINE OVER HEATED:**
 Air intake screen or fins clogged ----- clean intake screen and fins
 Fuel mixture too lean ----- readjust carburetor*
 Oil level too low or too high ----- adjust oil level
 Improper ignition timing ----- consult dealer
 Running engine too slow ----- run engine faster
 (NOTE: Always mow at full throttle setting.)
- 8. ENGINE IDLES POORLY:**
 Carburetor maladjustment ----- readjust carburetor
 Improper spark plug gap ----- check and re-gap plug*
- 9. ENGINE BACKFIRES:**
 Carburetor maladjustment ----- readjust carburetor*
- 10. ENGINE RUNS BUT MOWER WON'T MOVE FORWARD:**
 Drive belt broken or slipping ----- replace drive belt
 Transmission shift arm disconnected ----- reconnect
 Transmission oil low ----- add oil
 Transmission in free wheel position ----- tighten bypass valves (see pg. 8)
 Hydrostat oil filter plugged ----- replace filter
 Bad transmission ----- consult dealer
- 11. MOWER LOSES POWER OR TRANSMISSIONS OVER HEATS:**
 Hydrostat transmission oil too low or too high ----- add oil
 OR drain oil as needed
 Transmission damage ----- consult dealer
 Transmission blowing oil out cap ----- overfilled or water
 contaminated
- 12. ENGINE STALLS WHEN BLADES ARE ENGAGED:**
 Operator not on seat ----- sit on seat
 Faulty interlock system ----- consult dealer
 Bad blade spindle bearing ----- consult dealer
 Deck drive belt not properly routed ----- reroute
 Blades blocked by foreign material ----- clean under deck

* See engine manual for engine adjustments.

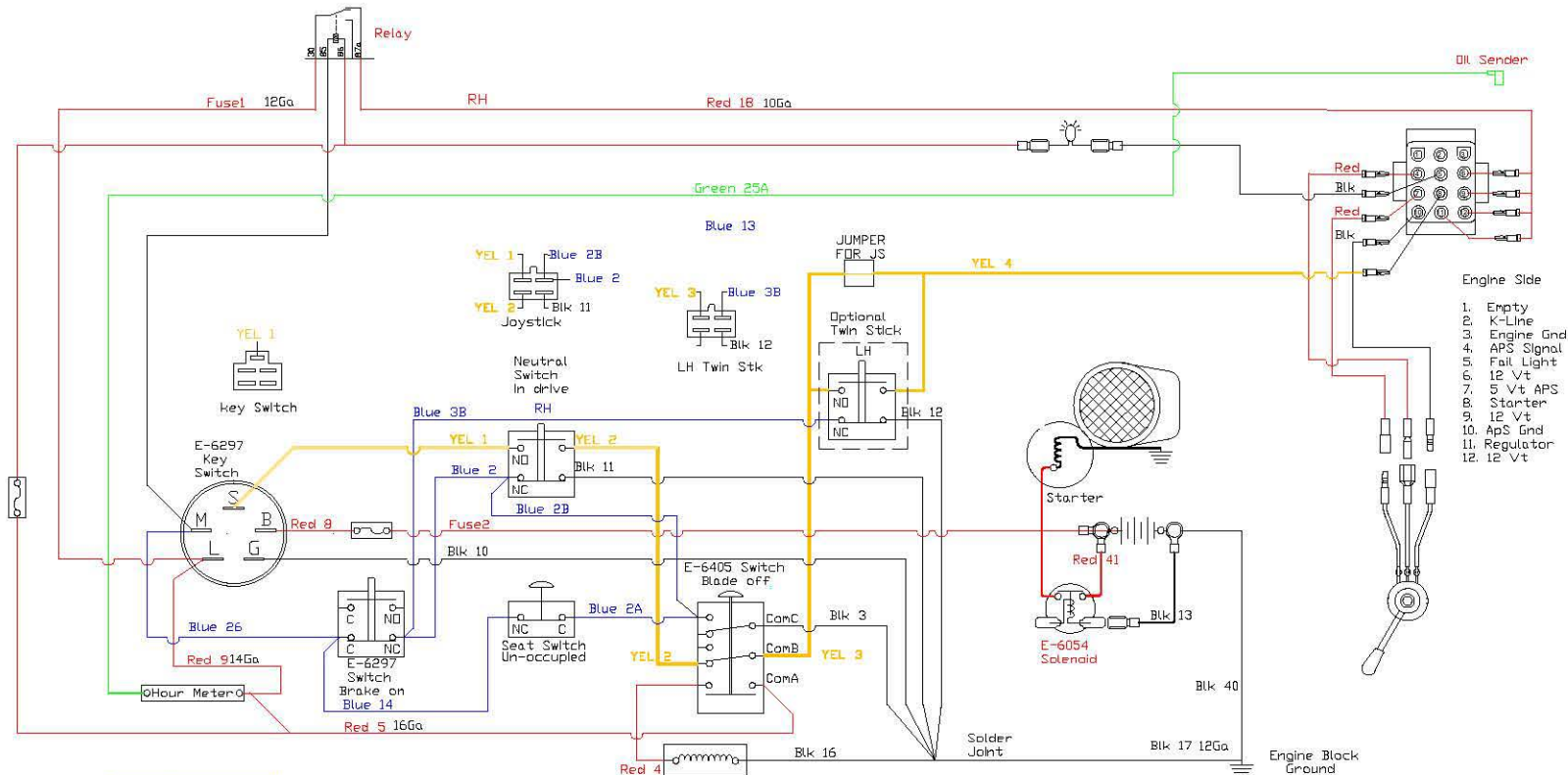

POSITION	CIRCUIT "MAKE"
1. OFF	G + M
2. RUN	B + L
3. START	B + L + S

To Start: Clutch not engaged & Steering Levers in Neutral
 Engine Kill: If Steering levers in drive & brake is on or seat un-occupied
 If Clutch is on and seat is not occupied

Start Circuit - Yellow
 Safety Circuit - Blue
 Power Circuit - Red
 Ground Circuit - Black
 Hr Mtr Circuit - Green

- Engine Side
1. Empty
 2. K-Line
 3. Engine Gnd
 4. APS Signal
 5. Fail Light
 6. 12 Vt
 7. 5 Vt APS
 8. Starter
 9. 12 Vt
 10. ApS Gnd
 11. Regulator
 12. 12 Vt

E-6472-Boss Kawasaki DFI Harness
 7-30-10 PWR

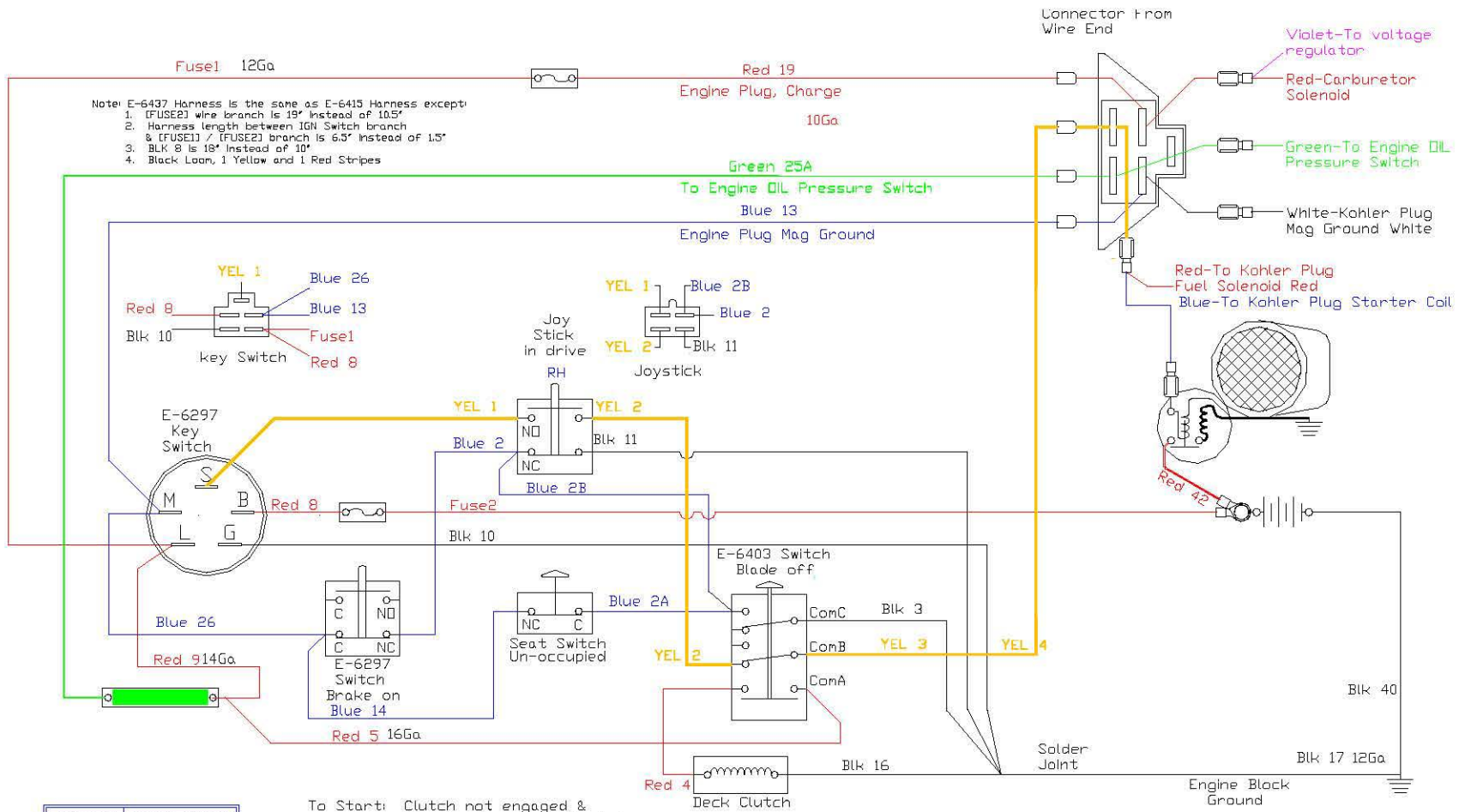

Note: E-6437 Harness is the same as E-6415 Harness except:
 1. (FUSE2) wire branch is 19" instead of 10.5"
 2. Harness length between IGH Switch branch & (FUSE1) / (FUSE2) branch is 6.9" instead of 1.5"
 3. BLK 8 is 18" instead of 10"
 4. Black Loom, 1 Yellow and 1 Red Stripes

POSITION	CIRCUIT "MAKE"
1. OFF	G + M
2. RUN	B + L
3. START	B + L + S

To Start: Clutch not engaged & Steering Levers in Neutral
 Engine Kill: If Steering levers in drive & brake is on or seat un-occupied
 If Clutch is on and seat is not occupied

Start Circuit Yellow
 Safety Circuit Blue
 Power Circuit Red
 Ground Circuit Black
 Hr Mtr Circuit Green

E-6437 Joystick/Kohler Wire Harness
 Black Loom, 1 Yellow stripe, 1 Red stripe
 Boss 6-4-06 *DHP*

Note: E-6438 Harness is the same as E-6416 Harness except:
 1. (FUSE2) wire branch is 19" instead of 10.5"
 2. Harness length between IGN Switch branch & (FUSE1) / (FUSE2) branch is 6.5" instead of 1.5"
 3. BLK 8 is 18" instead of 10"
 4. Harness is Black, with 1 Yellow and 2 Red Stripes

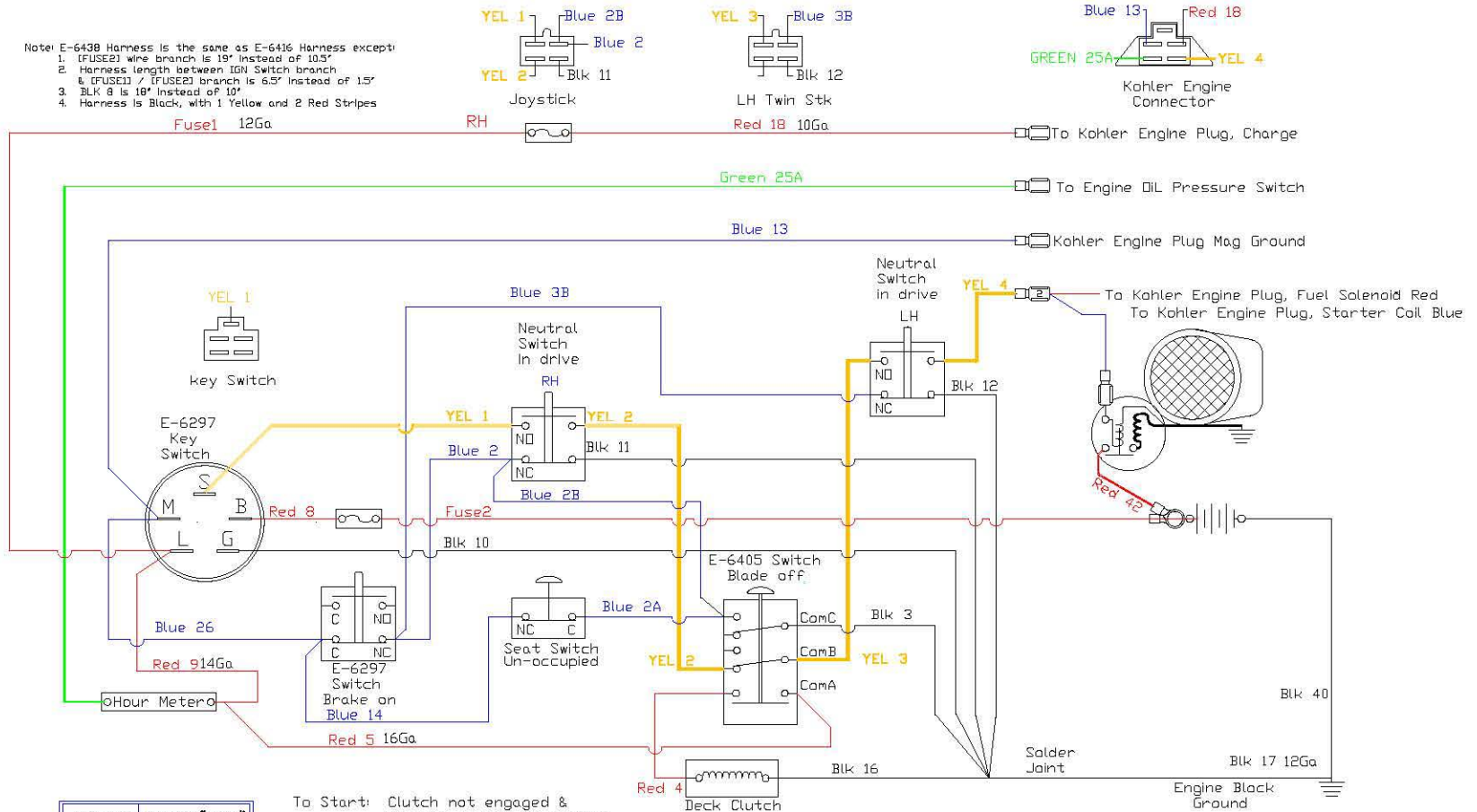

POSITION	CIRCUIT "MAKE"
1. OFF	G + M
2. RUN	B + L
3. START	B + L + S

To Start: Clutch not engaged & Steering Levers in Neutral
 Engine Kill: If Steering levers in drive & brake is on or seat un-occupied
 If Clutch is on and seat is not occupied

Start Circuit: Yellow
 Safety Circuit: Blue
 Power Circuit: Red
 Ground Circuit: Black
 Hr Mtr Circuit: Green

E-6438 Twin Stick Kohler Wire Harness
 Black Loom, 1 Yellow stripe, 2 Red Stripes
 Boss 4-13-06 DHP