

REPAIR PARTS MANUAL

FOR

COUNTRY
CLIPPER®

SR 1020



COUNTRY CLIPPER "CHARGER"

SR-1020

ZERO TURN RADIUS MOWER TABLE OF CONTENTS

PAGE.... CONTENTS

SECTION 1 – MOWER DECKS AND RELATED PARTS

- 1-1.... DOUBLE IDLER DECK ASSEMBLY
- 1-2.... DECK SPINDLE ASSEMBLY
- 1-3.... DOUBLE IDLER DRIVE BELT IDLER & RELATED PARTS
- 1-4.... LIFT HANDLE ASSEMBLY & RELATED PARTS
- 1-5.... LIFT ASSEMBLY & RELATED PARTS
- 1-6.... TRANSMISSION IDLERS & RELATED PARTS

SECTION 2 –TRACTOR FRAME AND RELATED PARTS

- 2-7....CASTER WHEEL ASSEMBLY
- 2-8....FRAME SIDES & RELATED PARTS
- 2-9....FENDER ASSEMBLY
- 2-10....SEAT, FOOT DECK & RELATED PARTS
- 2-11....FRONT STEP ASSEMBLY
- 2-12....ROLL OVER PROTECTION ASSEMBLY (R.O.P.S.)

SECTION 3 –TRACTOR DRIVE AND RELATED PARTS

- 3-13....FUEL TANK ASSEMBLY
- 3-14....JOYSTICK STEERING CONTROL & RELATED PARTS
- 3-15....JOYSTICK STEERING CONTROL & RELATED PARTS (continued)
- 3-16....STEERING CONTROL (TWIN STICK)
- 3-17....PARKING BRAKE ASSEMBLY & RELATED PARTS
- 3-18....GEAR MOTOR WHEEL ASSEMBLY
- 3-19....MOTOR ASSEMBLY & RELATED PARTS
- 3-20....HIGH PRESSURE LINES & FITTINGS
- 3-21....OIL RETURN LINES & COOLER ASSEMBLY
- 3-22....E-6415 WIRE HARNESS & RELATED PARTS
- 3-23....E-6416 WIRE HARNESS & RELATED PARTS
- 3-24....E-6417 WIRE HARNESS & RELATED PARTS

52" DECK ASSEMBLY

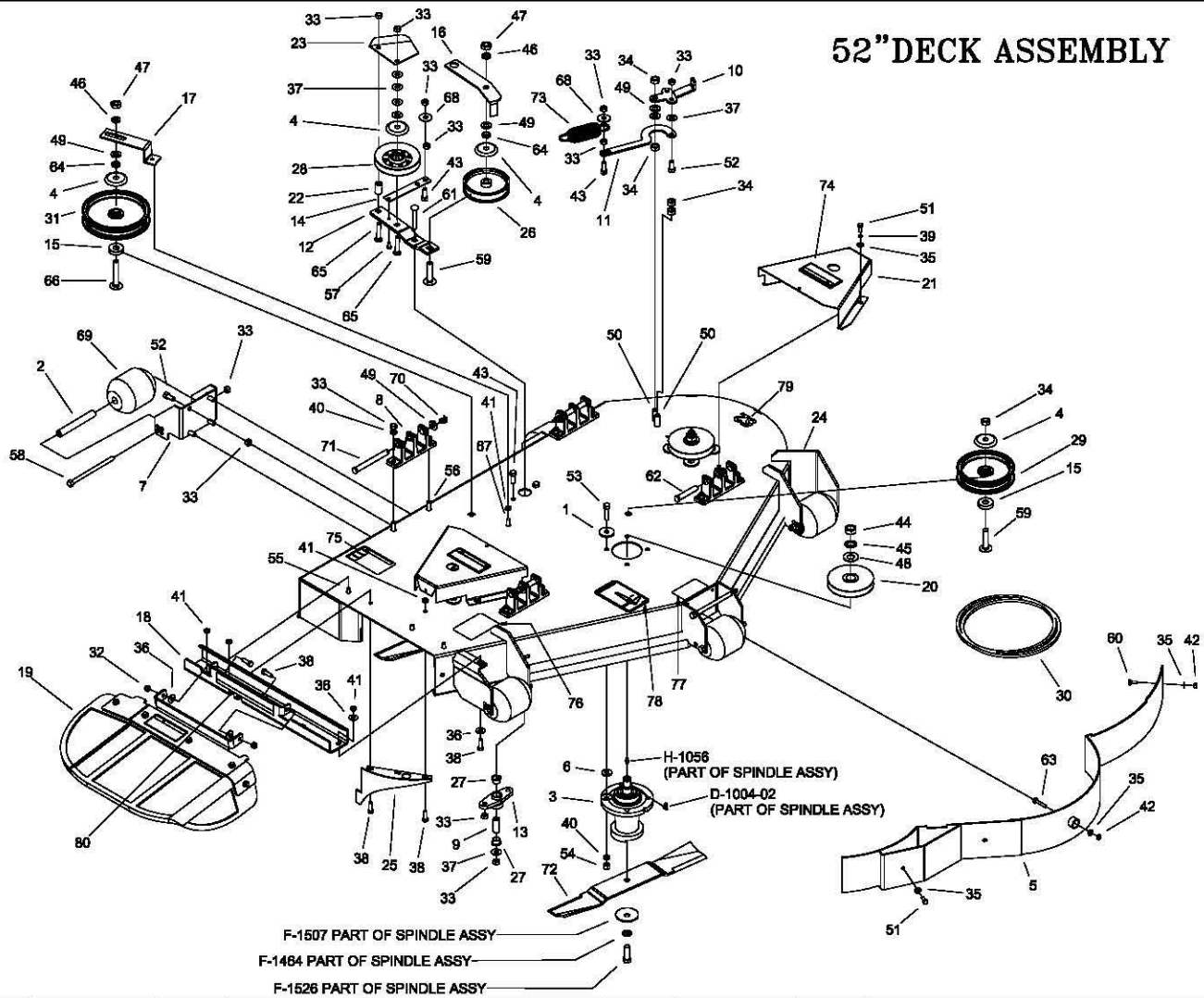

REF NO.	PART NO.	QTY.	DESCRIPTION	REF NO.	PART NO.	QTY.	DESCRIPTION
1	609-034P	12	Spindle Spacer Washer	45	F-1463	3	3/4 LOCKWASHER
2	609-183P	5	BUSHING	46	F-1464	2	1/2" LOCKWASHER
3	609F-019A	3	DECK SPINDLE ASSEMBLY	47	F-1489	2	1/2-13 Hex Jam Nut
4	620-201P	4	WASHER, BEARING CAP	48	F-1510	3	3/4 FLAT WASHER
5	629-229W	1	DUST BAFFLE, 52"	49	F-1521	8	1/2" WASHER, CUSTOM
6	629-237P	6	WASHER, .406 ID X 1 OD X 10 GA	50	F-1526	2	1/2-13 x 1-1/2" Capscrew
7	637-006P	2	SCALPER BRKT.	51	F-1538	5	1/4-20 x 3/4" Capscrew
8	643-016W	4	Hanger Weldment	52	F-1558	9	3/8-16 x 7/8" Capscrew
9	659-085P	1	Mounting Pin	53	F-1572	12	3/8-24 x 1.5" Capscrew
10	660-030P	1	Belt Tightner Handle	54	F-1573	12	3/8-24 LOCKNUT
11	660-031P	1	Belt Tightner Arm	55	F-1671	3	5/16-18 x 3/4" CARRIAGE BOLT
12	660-036P	1	Idler Arm	56	F-1672	8	3/8-16 x 1-1/4" Carriage Bolt
13	660-039P	1	Double Idler Mount	57	F-1733	1	1/4" x 1/2" DRIVE SCREW
14	660-081P	1	EXTENSION FOR SPRING	58	F-1741	6	3/8-16 x 6" Capscrew
15	660-082P	2	SPACER	59	F-1822	2	1/2-13 X 2-7/8" CARRIAGE BOLT
16	660-107P	1	BELT KEEPER	60	F-1823	1	Carriage Bolt, 1/4 X 3/4"
17	660-114P	1	BELT KEEPER, SINGLE END	61	F-1865	1	3/8-16 x 2-1/2" Carriage Bolt
18	660-120P	1	OUTLET STIFFENER, SMALL	62	F-1889	2	1/2 x 2-5/8" Clevis Pin
19	660-122A	1	RUBBER CHUTE ASS'Y, SM.	63	F-1935	1	CARRIAGE BOLT, 1/4 X 1-1/2"
20	668-013P	3	PULLEY, 52"	64	F-1966	2	1/2-13 THIN NYLOC NUT
21	668-016P	2	PULLEY COVER	65	F-1976	2	3/8-16 x 2" Carriage Bolt
22	668-021P	1	SPACER, BELT GUARD	66	F-2047	1	1/2-13 X 3" CARRIAGE BOLT
23	668-029P	1	BELT GUARD	67	F-2066	1	5/16-18 x 1" CARRIAGE BOLT,
24	668J-003W	1	52" HEAVY DECK WELDMENT	68	F-2083	2	WASHER, 3/8 FENDER
25	668-006W	1	SPLITTER BAFFLE	69	H-1948	5	Roller, 3-3/4 DIA. x 4-13/16L
26	D-3338	1	Pulley flat idler 1/2" Bore 4"	70	H-2239	4	1/2" Rug Ring
27	D-3730	2	Flanged Bushing 5/8" Bore	71	H-2240	2	1/2" x 4-1/2" Clevis Pin
28	D-3758	1	PULLEY V-IDLER 4.48 O.D. 3/8 HOLE	72	H-2499	3	18-3/8 High lift blade
29	D-3774	1	IDLER PULLEY 5"	73	H-2619	1	SPRING, 5 X 1-1/2, TAPERED ENDS
30	D-3778-W	1	BELT, B-180	74	P-10935	2	Decal, WARNING
31	D-3815	1	IDLER PULLEY 6"	75	P-10941	1	DECAL "DANGER ROTATING BLADES"
32	F-1005-02	2	5/16-18 Nyloc Nut	76	P-10947	1	DECAL "GREASE DECK SPINDLES"
33	F-1005-03	32	3/8-18 Stover Nut	77	P-11413	1	DECAL, HOIST POINT
34	F-1005-05	5	1/2-13 Stover Nut	78	P-11932	1	DECAL, JAZEE DECK BELT ROUTING
35	F-1009-01	7	1/4" Flat Washer	79	P-11951	1	DECAL, DECK SIZE, 52
36	F-1009-02	4	5/16" Flat Washer	80	P-12496	1	DECAL, MISSING CHUTE
37	F-1009-03	6	3/8" Flat Washer				
38	F-1015-15	5	5/16-18 x 1" Capscrew				
39	F-1019-01	4	1/4" LockWasher				
40	F-1019-03	20	3/8" LOCKWASHER				
41	F-1125	7	5/16-18 Stover Nut				
42	F-1158	2	1/4-20 Stover Nut				
43	F-1394	4	3/8-16 x 1" Capscrew				
44	F-1461	3	3/4-16 JAM NUT				

52" TRI-PORT DECK ASSEMBLY

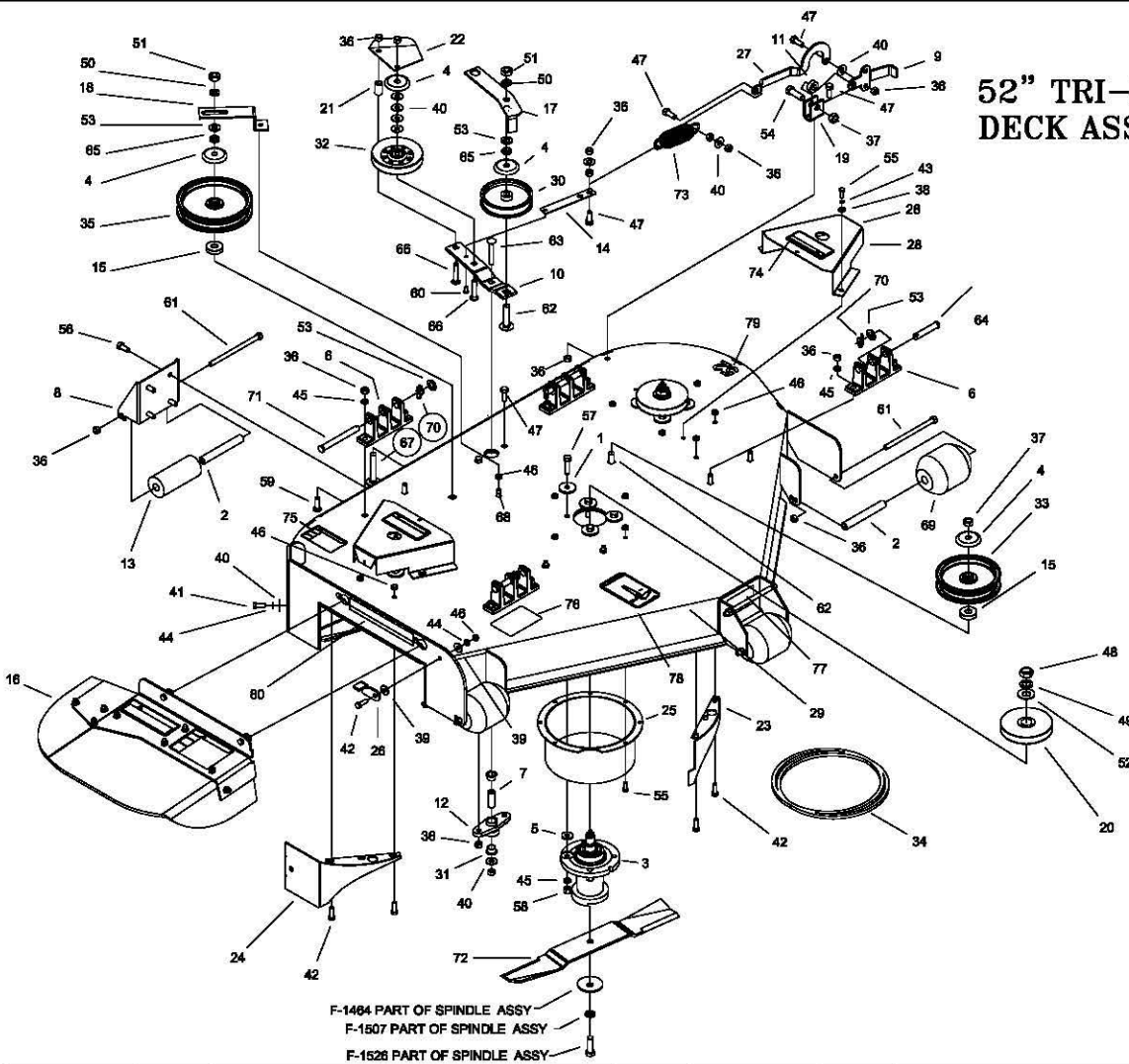

REF NO.	PART NO.	QTY.	DESCRIPTION	REF NO.	PART NO.	QTY.	DESCRIPTION
1	808-034P	12	Spindle Spacer Washer	43	F-1019-01	4	1/4" LockWasher
2	808-183P	5	BUSHING	44	F-1019-02	2	5/16" LockWasher
3	809F-018A	3	DECK SPINDLE ASSEMBLY	45	F-1019-03	20	3/8" LOCKWASHER
4	820-201P	4	WASHER, BEARING CAP	46	F-1125	16	5/16-18 Stover Nut
5	828-237P	8	WASHER, .406 ID X 1 OD X 10 GA	47	F-1394	8	3/8-16 x 1" Capscrow
6	843-016W	4	Hanger Weldment	48	F-1461	3	3/4-16 JAM NUT
7	858-085P	1	Mounting Pin	49	F-1463	3	3/4 LOCKWASHER
8	858-139P	2	SCALPER BRACKET	50	F-1484	2	1/2" LOCKWASHER
9	880-030P	1	Belt Tightner Handle	51	F-1489	2	1/2-13 Hex Jam Nut
10	880-036P	1	Idler Arm	52	F-1510	3	3/4 FLAT WASHER
11	880-038P	1	3/8" Spacer	53	F-1521	6	1/2" WASHER, CUSTOM
12	880-039P	1	Double Idler Mount	54	F-1528	1	1/2-13 x1-1/2" Capscrow
13	880-078P	2	ROLLER	55	F-1538	14	1/4-20 x 3/4" Capscrow
14	880-081P	1	EXTENSION FOR SPRING	56	F-1558	8	3/8-16 x 7/8" Capscrow
15	880-082P	2	SPACER	57	F-1572	12	3/8-24 x 1.5" Capscrow
16	880-102A	1	DECK CHUTE ASSEMBLY, SMALL	58	F-1573	12	3/8-24 LOCKNUT
17	880-107P	1	BELT KEEPER	59	F-1672	8	3/8-16 x 1-1/4" Carriage Bolt
18	880-114P	1	BELT KEEPER, SINGLE END	60	F-1733	1	1/4" x 1/2" DRIVE SCREW
19	881-015P	1	SHACKLE	61	F-1741	6	3/8-16 x 8" Capscrow
20	888-013P	3	PULLEY, 52"	62	F-1822	2	1/2-13 X 2-1/4" CARRIAGE BOLT
21	888-021P	1	SPACER, BELT GUARD	63	F-1865	1	3/8-16 x 2-1/2" Carriage Bolt
22	888-029P	1	BELT GUARD	64	F-1889	2	1/2 x 2-5/8" Clevis Pin
23	888-006W	2	SPLITTER BAFFLE	65	F-1966	2	1/2-13 THIN NYLOC NUT
24	888-018W	1	BAFFLE, DISCHARGE WLDT	66	F-1978	2	3/8-16 x 2" Carriage Bolt
25	888-059W	3	8" TUBE WLDT.	67	F-2047	1	1/2-13 X 3" CARRIAGE BOLT
26	888-079P	1	LATCH	68	F-2066	1	5/16-18 x 1" CARRIAGE BOLT,
27	888-081P	1	BELT TENSIONER	69	H-1948	3	Roller, 3-3/4 DIA. x 4-13/16L
28	888-082P	2	PULLEY COVER	70	H-2239	4	1/2" Rue Ring
29	888J-003W	1	52" CHARGER TRIPORT DECK WLDT	71	H-2240	2	1/2" x 4-1/2" Clevis Pin
30	D-3338	1	Pulley flat Idler 1/2" Bore 4"	72	H-2489	3	18-3/8 High lift blade
31	D-3730	2	Flanged Bushing 5/8" Bore	73	H-2819	1	SPRING,5 X 1-1/2,TAPERED ENDS
32	D-3758	1	PULLEY V-IDLER 4.48 O.D. 3/8 HOLE	74	P-10935	2	Decal, WARNING
33	D-3774	1	IDLER PULLEY 5"	75	P-10941	1	DECAL "DANGER ROTATING BLADES"
34	D-3776-W	1	BELT, B-180	76	P-10947	1	DECAL "GREASE DECK SPINDLES"
35	D-3815	1	IDLER PULLEY 6"	77	P-11413	1	DECAL, HOIST POINT
36	F-1005-03	33	3/8-18 Stover Nut	78	P-11932	1	DECAL, JAZEE DECK BELT ROUTING
37	F-1005-05	2	1/2-13 Stover Nut	79	P-11951	1	DECAL, DECK SIZE, 52
38	F-1009-01	4	1/4" Flat Washer	80	P-12496	1	DECAL, MISSING CHUTE
39	F-1009-02	2	5/16" Flat Washer				
40	F-1009-03	9	3/8" Flat Washer				
41	F-1015-14	1	5/16-18 x 7/8" Capscrow				
42	F-1015-15	7	5/16-18 x 1" Capscrow				

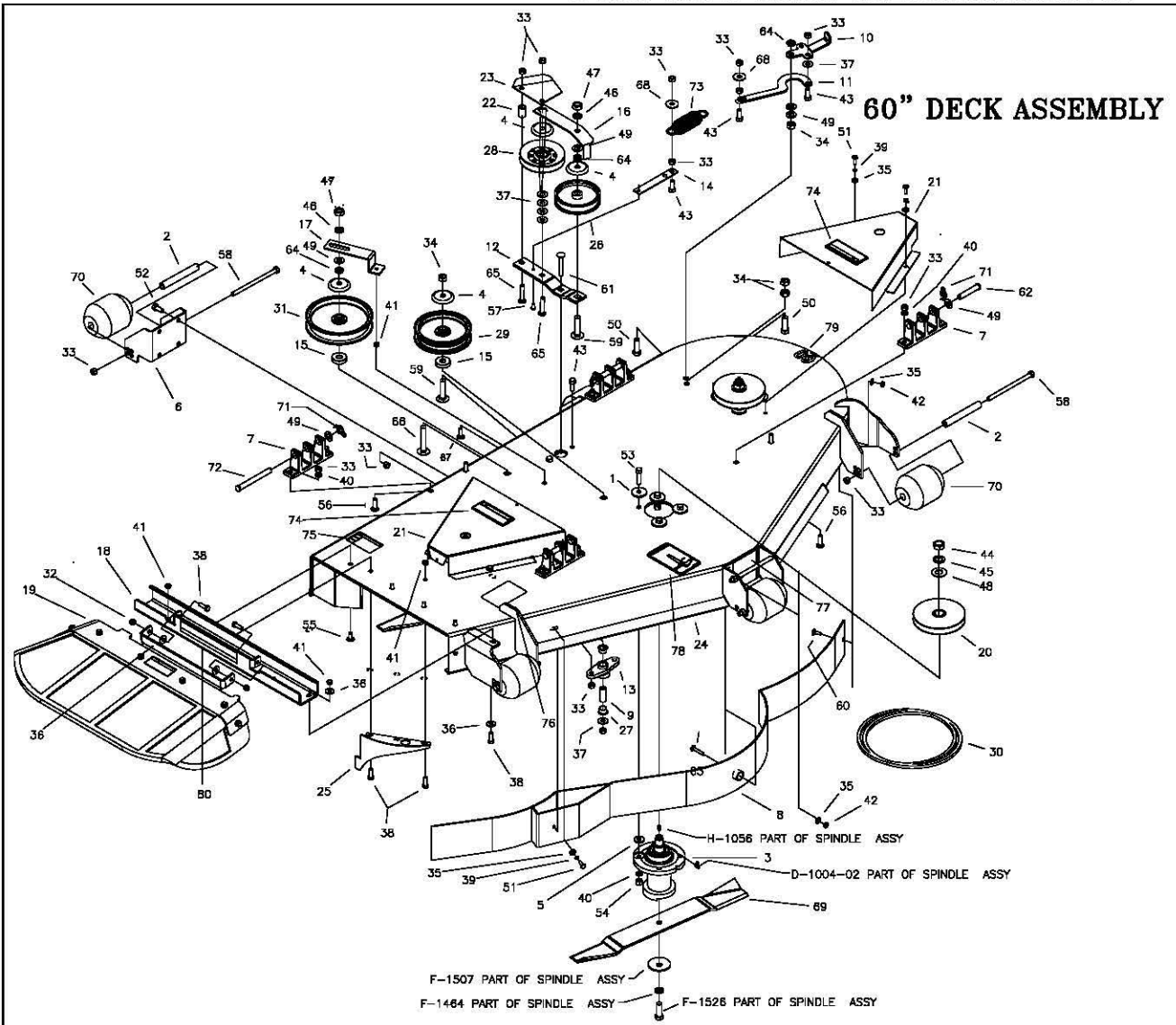

REF NO.	PART NO.	QTY.	DESCRIPTION	REF NO.	PART NO.	QTY.	DESCRIPTION
1	609-034P	12	Spindle Spacer Washer	43	F-1394	5	3/8-16 x 1" Capcrew
2	608-183P	5	BUSHING	44	F-1461	3	3/4-16 JAM NUT
3	609F-019A	3	DECK SPINDLE ASSEMBLY	45	F-1463	3	3/4 LOCKWASHER
4	620-201P	4	WASHER, BEARING CAP	46	F-1464	2	1/2" LOCKWASHER
5	629-237P	8	WASHER, .406 ID X 1 OD X 10 GA	47	F-1489	2	1/2-13 Hex Jam Nut
6	637-006P	2	SCALPER BRKT.	48	F-1510	3	3/4 FLAT WASHER
7	643-016W	4	Hanger Weldment	49	F-1521	8	1/2" WASHER, CUSTOM
8	643-047W	1	DUST BAFFLE	50	F-1526	2	1/2-13 x 1-1/2" Capcrew
9	659-086P	1	Mounting Pin	51	F-1538	5	1/4-20 x 3/4" Capcrew
10	660-030P	1	Belt Tightner Handle	52	F-1558	8	3/8-16 x 7/8" Capcrew
11	660-031P	1	Belt Tightner Arm	53	F-1572	12	3/8-24 x 1.5" Capcrew
12	660-036P	1	Idler Arm	54	F-1573	12	3/8-24 LOCKNUT
13	660-039P	1	Double Idler Mount	55	F-1671	4	5/16-18 x 3/4" CARRIAGE BOLT
14	660-081P	1	EXTENSION FOR SPRING	56	F-1672	8	3/8-16 x 1-1/4" Carriage Bolt
15	660-082P	2	SPACER	57	F-1733	1	1/4" x 1/2" DRIVE SCREW
16	660-107P	1	BELT KEEPER	58	F-1741	6	3/8-16 x 6" Capcrew
17	660-114P	1	BELT KEEPER, SINGLE END	59	F-1822	2	1/2-13 X 2-1/4" CARRIAGE BOLT
18	660-123P	1	OUTLET STIFFENER, LARGE	60	F-1823	1	Carriage Bolt, 1/4 X 3/4"
19	660-125A	1	RUBBER CHUTE ASSEMBLY, LARGE	61	F-1865	1	3/8-16 x 2-1/2" Carriage Bolt
20	668-012P	3	PULLEY, 60"	62	F-1889	2	1/2 x 2-5/8" Clevis Pin
21	668-017P	2	PULLEY COVER	63	F-1935	1	CARRIAGE BOLT, 1/4 X 1-1/2"
22	668-021P	1	SPACER, BELT GUARD	64	F-1966	3	1/2-13 THIN NYLON NUT
23	668-029P	1	BELT GUARD	65	F-1976	2	3/8-16 x 2" Carriage Bolt
24	668K-003W	1	80" HEAVY DECK WELDMENT	66	F-2047	1	1/2-13 X 3" CARRIAGE BOLT
25	668-006W	1	SPLITTER BAFFLE	67	F-2066	1	5/16-18 x 1" CARRIAGE BOLT
26	D-3338	1	Pulley flat Idler 1/2" Bore 4"	68	F-2083	2	WASHER, 3/8 FENDER
27	D-3730	2	Flanged Bushing 5/8" Bore	69	H-2500	3	80" HIGH LIFT BLADE
28	D-3758	1	PULLEY V-IDLER 4.48 O.D. 3/8 HOLE	70	H-1948	5	Roller, 3-3/4 DIA. x 4-13/16L
29	D-3774	1	IDLER PULLEY 5"	71	H-2238	4	1/2" Rue Ring
30	D-3776-W	1	BELT, B-180	72	H-2240	2	1/2" x 4-1/2" Clevis Pin
31	D-3815	1	IDLER PULLEY 6"	73	H-2618	1	SPRING, 5 x 1-1/2, TAPERED ENDS
32	F-1005-02	2	5/16-18 Nyloc Nut	74	P-10935	2	Decal, WARNING
33	F-1005-03	32	3/8-16 Stover Nut	75	P-10941	1	DECAL "DANGER ROTATING BLADES"
34	F-1005-05	4	1/2-13 Stover Nut	76	P-10947	1	DECAL " GREASE DECK SPINDLES"
35	F-1009-01	7	1/4" Flat Washer	77	P-11413	1	DECAL, HOIST POINT
36	F-1009-02	4	5/16" Flat Washer	78	P-11932	1	DECAL, JAZZEE DECK BELT ROUTING
37	F-1009-03	6	3/8" Flat Washer	79	P-11952	1	DECAL, DECK SIZE, 60
38	F-1015-15	5	5/16-18 x 1" Capcrew	80	P-12496	1	DECAL, MISSING CHUTE
39	F-1019-01	5	1/4" LockWasher				
40	F-1019-03	20	3/8" LOCKWASHER				
41	F-1125	8	5/16-18 Stover Nut				
42	F-1158	2	1/4-20 Stover Nut				

DECK SPINDLE ASSEMBLY 609F-019A

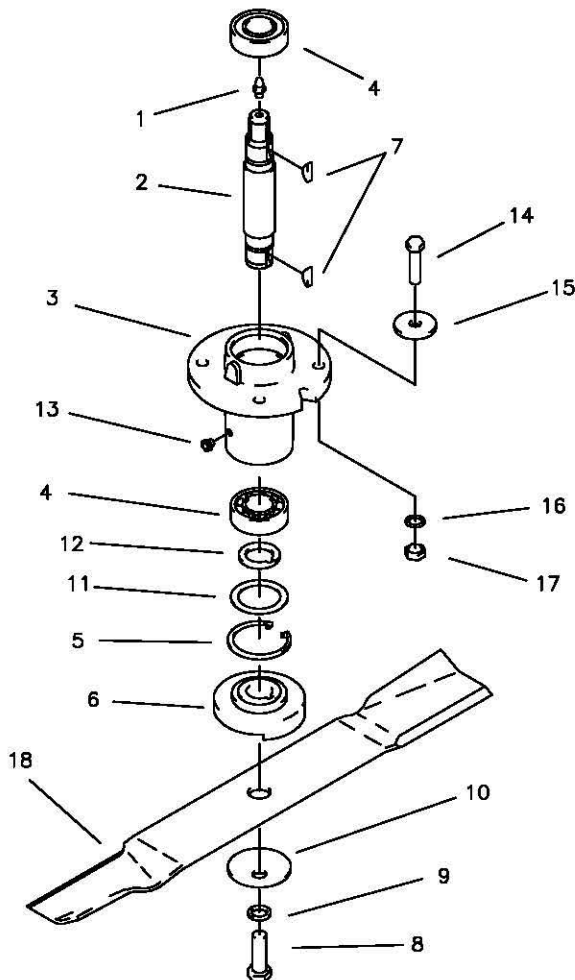

REF NO.	PART NO.	QTY.	DESCRIPTION	REF NO.	PART NO.	QTY.	DESCRIPTION
1	H-1056	1	GREASE FITTING	17	F-1573	4	3/8-24 LOCKNUT
2	609-162P	1	SPINDLE SHAFT	18	H-2499	-	BLADE, HIGH L, 18 3/8" CUT 52"
3	660-028P	1	SPINDLE HOUSING (660-045A)		H-2500	-	BLADE, HIGH L, 21" CUT 60"
-	609-223P	1	SPINDLE HOUSING (609F-019A)	OPTIONAL BLADES			
4	D-3058	2	BEARING, #6205-2RS				
5	H-1893	1	SNAP RING INT. 52MM				
6	609-152P	1	BLADE SPACER				
7	D-1004-02	2	KEY, WOODRUF, 1/4 X 3/4				
8	F-1526	1	1/2-13 X 1 1/2" HHCS GR. 5				
9	F-1464	1	1/2" LOCK WASHER				
10	F-1507	1	WASHER, 1/2" CUPPED				
11	609-151P	1	WASHER, SEAL	H-2387	-	BLADE, LOW L, 18 3/8" CUT, 52"	
12	609-073P	1	ARBOR SPACER	H-1667	-	BLADE, LOW L, 21" CUT, 60"	
13	H-2066	1	GREASE VENT 5 LBS.	H-2251	-	BLADE, GATOR, 18 3/8" CUT 52"	
14	F-1572	4	3/8-24 X 1 1/2" HHCS GR. 5	H-2203	-	BLADE, GATOR, 21" CUT 60"	
15	609-034P	4	SPINDLE SPACER REINFORCEMENT				
16	F-1019-03	4	3/8" LOCK WASHER				

DOUBLE IDLER DRIVE BELT IDLER & RELATED PARTS 52" & 60" DECKS

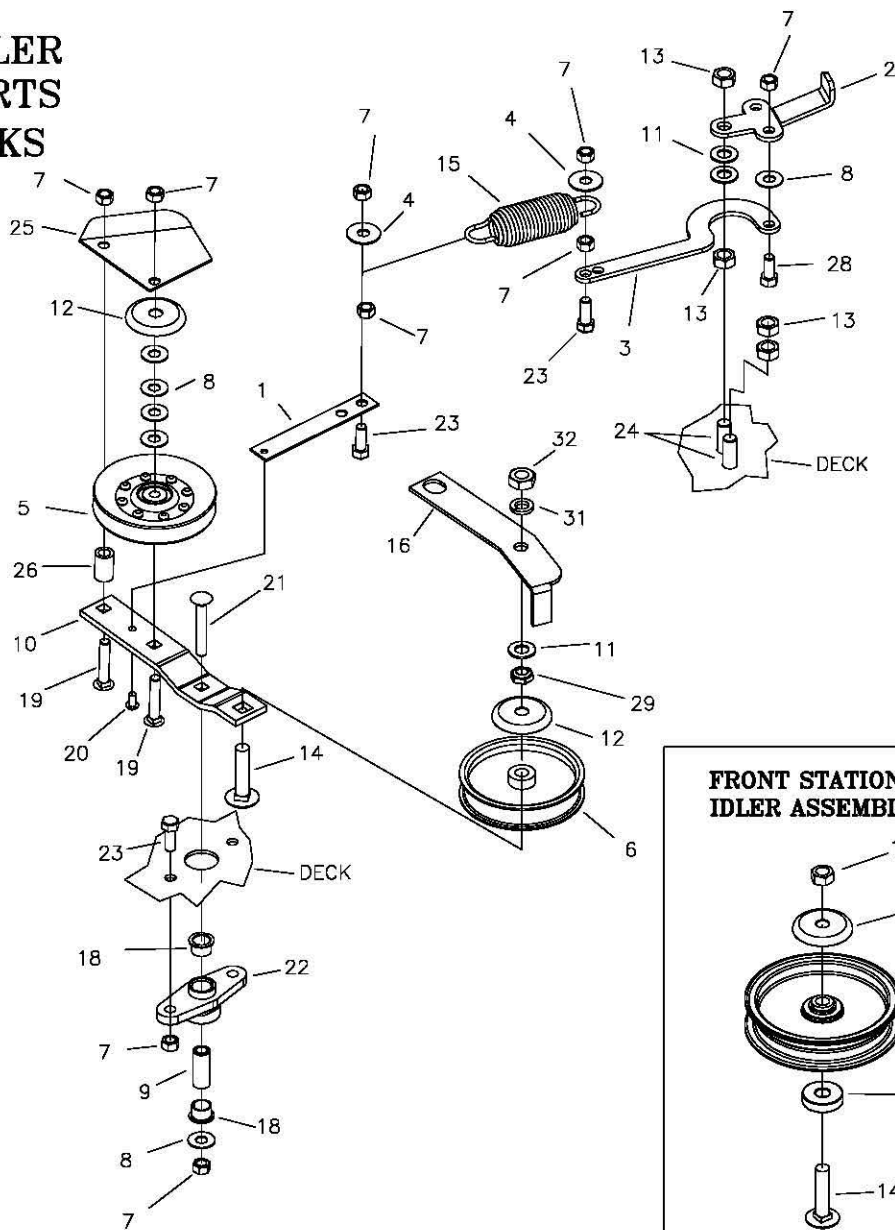

RIGHT REAR STATIONARY IDLER ASSEMBLY

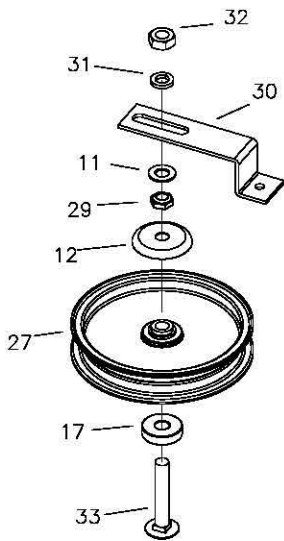

FRONT STATIONARY IDLER ASSEMBLY

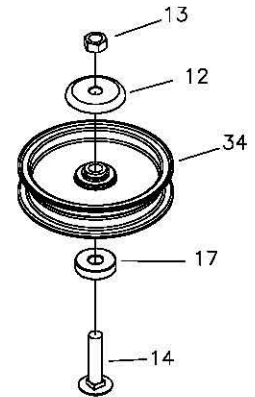

REF NO.	PART NO.	QTY.	DESCRIPTION	REF NO.	PART NO.	QTY.	DESCRIPTION
1	660-081P	1	EXTENSION FOR SPRING	22	660-039P	1	MOUNT, DOUBLE IDLER
2	660-030P	1	HANDLE, BELT TIGHTENER	23	F-1394	4	3/8-16 X 1" GR. 5
3	660-031P	1	ARM, BELT TIGHTENER	24	F-1526	2	1/2-13 X 1-1/2" GR. 5
4	F-2083	2	WASHER, 3/8 FENDER	25	668-029P	1	BELT GUARD
5	D-3758	1	"V" IDLER PULLEY	26	668-021P	1	SPACER, BELT GUARD
6	D-3338	2	IDLER PULLEY	27	D-3815	1	5" IDLER PULLEY
7	F-1005-03	10	3/8 LOCK NUT	28	F-1558	1	3/8-16 X 7/8 GR. 5
8	F-1009-03	6	3/8 FLAT WASHER	29	F-1966	4	1/2" THIN NYLOC NUT
9	659-085P	1	MOUNTING PIN	30	660-114P	1	BELT KEEPER, SINGLE END
10	660-036P	1	IDLER ARM	31	F-1464	2	1/2" LOCK WASHER
11	F-1521	4	1/2" FLAT WASHER	32	F-1489	2	1/2" THIN NUT
12	620-201P	4	BEARING CAP	33	F-2047	1	1/2"-13 X 3" CARRIAGE BOLT
13	F-1005-05	5	1/2" LOCK NUT	34	D-3774	1	IDLER PULLEY 5"
14	F-1822	2	1/2-13 X 2-1/4" GR. 5				
15	H-2619	1	SPRING, 5x1-1/2, TAPERED ENDS				
16	660-107P	1	BELT KEEPER				
17	660-082P	1	SPACER				
18	D-3730	2	BUSHING, TEFLON COATED				
19	F-1976	2	3/8-16 X 1-3/4" CARRIAGE BOLT				
20	F-1733	1	1/4" DRIVE STUD				
21	F-1865	1	3/8-16 X 2-1/2" CARRIAGE BOLT				

**DOUBLE IDLER
DRIVE BELT IDLER
& RELATED PARTS
52" TRI-PORT DECKS**

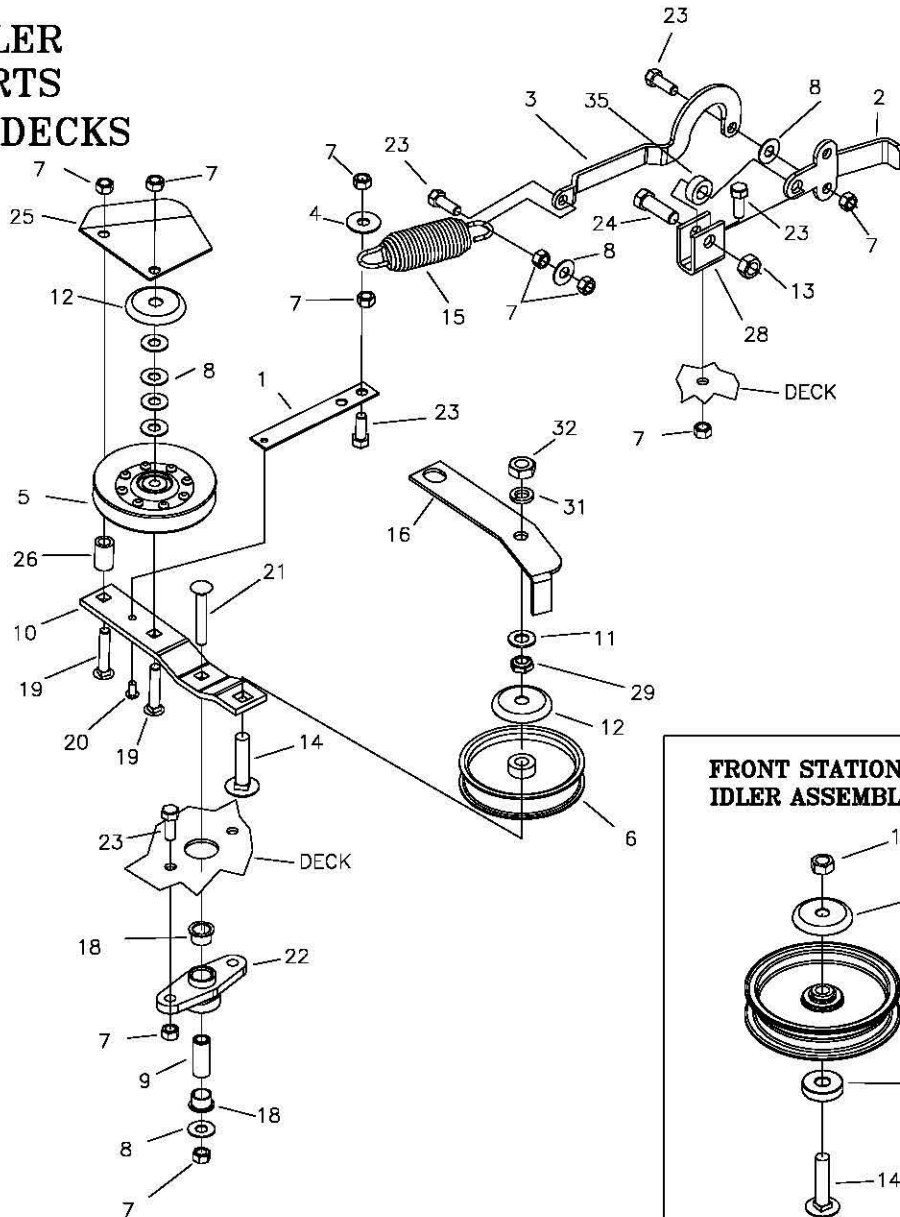

**RIGHT REAR STATIONARY
IDLER ASSEMBLY**

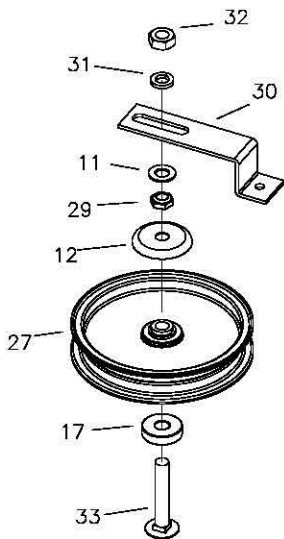

**FRONT STATIONARY
IDLER ASSEMBLY**

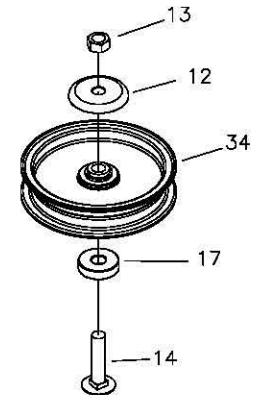

REF NO.	PART NO.	QTY.	DESCRIPTION	REF NO.	PART NO.	QTY.	DESCRIPTION
1	660-081P	1	EXTENSION FOR SPRING	22	660-039P	1	MOUNT, DOUBLE IDLER
2	660-030P	1	HANDLE, BELT TIGHTENER	23	F-1394	6	3/8-16 X 1" GR. 5
3	668-081P	1	BELT TENSIONER	24	F-1526	1	1/2-13 X 1-1/2" GR. 5
4	F-2083	2	WASHER, 3/8 FENDER	25	668-029P	1	BELT GUARD
5	D-3758	1	"V" IDLER PULLEY	26	668-021P	1	SPACER, BELT GUARD
6	D-3338	2	IDLER PULLEY	27	D-3815	1	5" IDLER PULLEY
7	F-1005-03	11	3/8 LOCK NUT	28	661-015P	1	SHACKLE
8	F-1009-03	8	3/8 FLAT WASHER	29	F-1966	4	1/2" THIN NYLOC NUT
9	659-085P	1	MOUNTING PIN	30	660-114P	1	BELT KEEPER, SINGLE END
10	660-036P	1	IDLER ARM	31	F-1464	2	1/2" LOCK WASHER
11	F-1521	4	1/2" FLAT WASHER	32	F-1489	2	1/2" THIN NUT
12	620-201P	4	BEARING CAP	33	F-2047	1	1/2"-13 X 3" CARRIAGE BOLT
13	F-1005-05	2	1/2" LOCK NUT	34	D-3774	1	IDLER PULLEY 5"
14	F-1822	2	1/2-13 X 2-1/4" GR. 5	35	660-038P	1	3/8" SPACER
15	H-2619	1	SPRING, 5x1-1/2, TAPERED ENDS				
16	660-107P	1	BELT KEEPER				
17	660-082P	1	SPACER				
18	D-3730	2	BUSHING, TEFLON COATED				
19	F-1976	2	3/8-16 X 1-3/4" CARRIAGE BOLT				
20	F-1733	1	1/4" DRIVE STUD				
21	F-1865	1	3/8-16 X 2-1/2" CARRIAGE BOLT				

LIFT HANDLE ASSEMBLY & RELATED PARTS

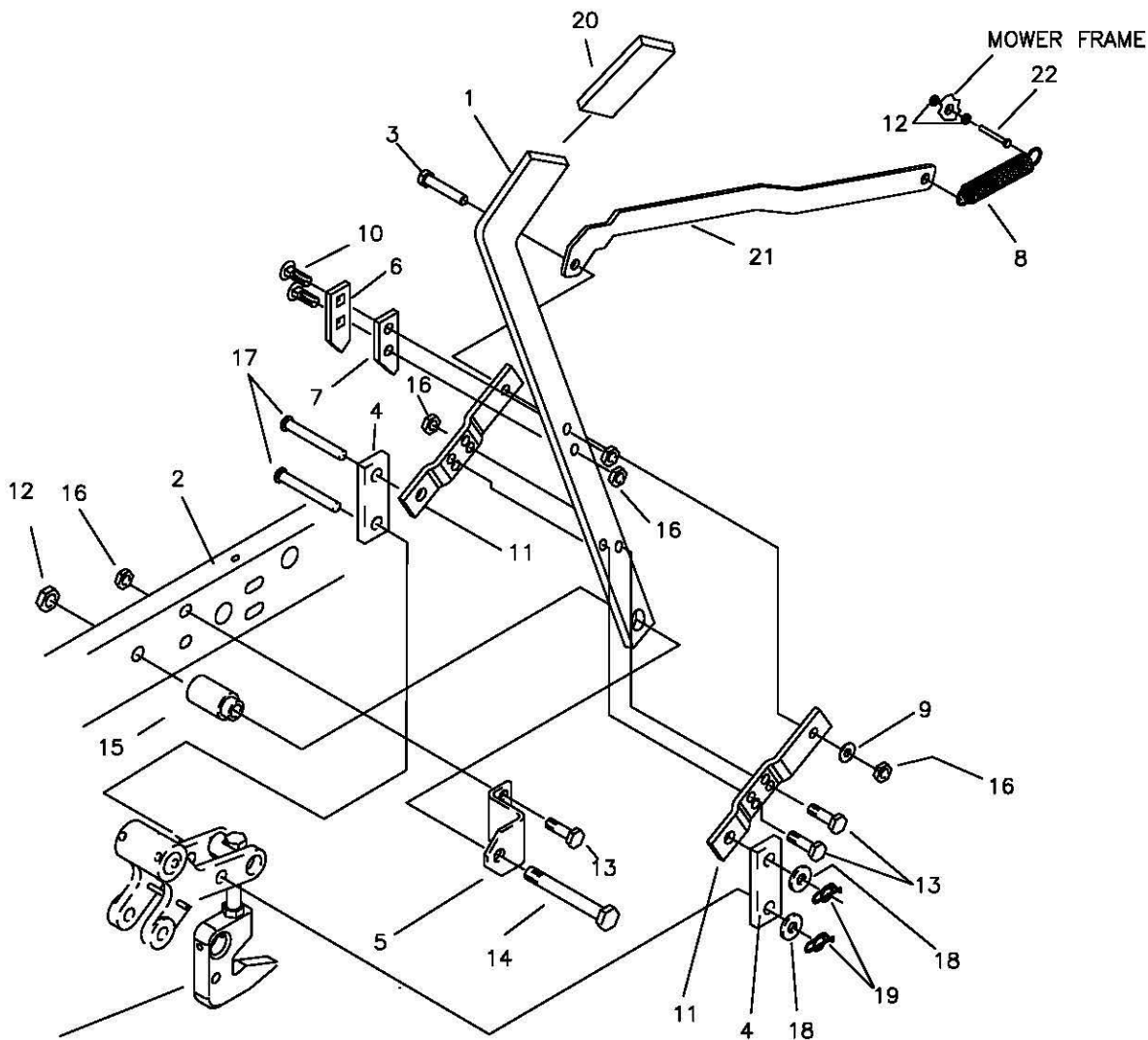

SEE ASSEMBLY NUMBER
PAGE 1-5

REF NO.	PART NO.	QTY.	DESCRIPTION	REF NO.	PART NO.	QTY.	DESCRIPTION
1	659-060P	1	LIFT HANDLE	15	642-095P	1	HANDLE PIVOT PIN
2	659-022W	1	FRAME WELDMENT, LH.	16	F-1005-03	5	NUT, 3/8-16 LOCKNUT (STOVER)
3	F-1073	1	3/8-16 X 2" CAPSCREW	17	F-1889	2	CLEVIS PIN, 1/2 X 2 5/8"
4	642-061P	2	HANDLE LINK	18	F-1521	2	1/2" FLAT WASHER
5	642-041P	1	HANDLE PIVOT BRACKET	19	H-2239	2	RUE RING, 1/2"
6	642-127P	1	TOP PEG LATCH PLATE	20	H-2324	1	VINYL GRIP, 3/8 X 1 1/2"
7	642-126P	1	TOP PEG SPACER PLATE	21	663-080P	1	BAR, SPRING EXT.
8	H-1610	1	SPRING, 1 1/2" OD. X 8"	22	F-1293	1	1/2-13 X 3" GR. 5
9	F-1009-03	1	FLAT WASHER, 3/8"				
10	F-1672	2	CARRIAGE BOLT, 3/8-16 X 1 1/4"				
11	642-060P	2	SPRING ANCHOR PLATE				
12	F-1005-05	1	NUT, 1/2-13 LOCKNUT				
13	F-1307	4	1/2-13 X 1 1/4" GR. 5				
14	F-1439	1	1/2-13 X 3" GR. 5				

LIFT ASSEMBLY & RELATED PARTS

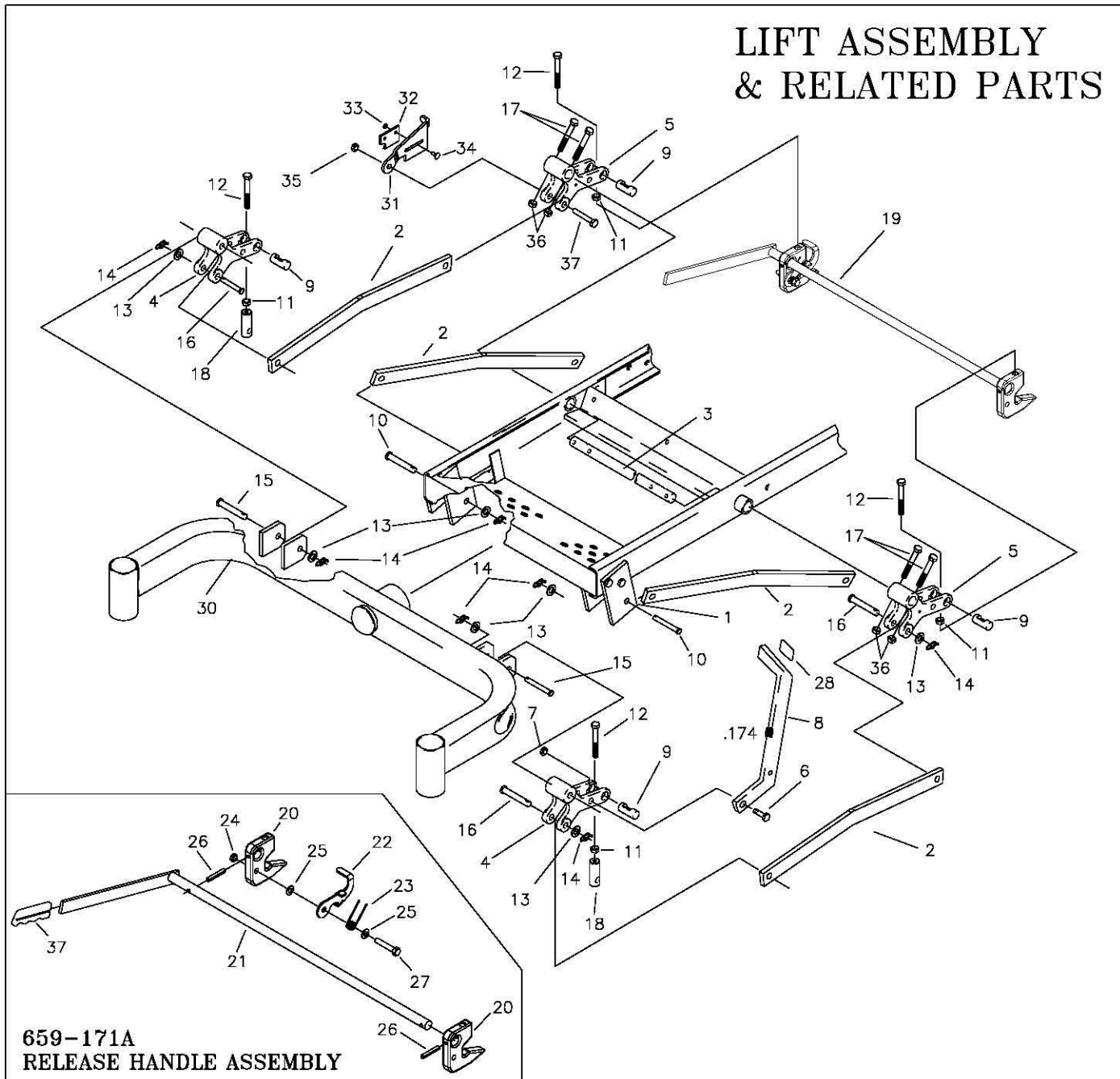

**659-171A
RELEASE HANDLE ASSEMBLY**

REF NO.	PART NO.	QTY.	DESCRIPTION	REF NO.	PART NO.	QTY.	DESCRIPTION
1	642-063P	2	DRAG BAR TAB	20	659-140P	2	DECK HOOK
2	659-155P	4	DRAG LINK BAR	21	659-148W	1	RELEASE HANDLE WELDMENT
3	620-051P	1	LIFT BAR	22	659-145P	1	HOOK KEEPER
4	642-081P	2	LIFT SLEEVE, FRONT	23	H-2547	1	SPRING, TORSION
5	642-082P	2	LIFT SLEEVE, REAR	24	F-1005-03	1	NUT, 3/8-16, STOVER
6	F-1879	1	5/16-18 X 1 1/4" GR.5	25	F-1009-03	2	WASHER, FLAT, 3/8"
7	F-1125	1	5/16-18 STOVER NUT	26	F-2009	2	SPIROL ROLL PIN 1/4 X 1-1/2
8	659-056P	1	DECK LIFT PEDAL	27	F-1073	1	CAPSCREW, 3/8-16 X 2, GR. 5
9	642-177P	4	HANGER PIN	28	H-2401	1	TREAD PAD
10	F-1896	2	CLEVIS PIN, 1/2 X 1 3/4"	29	H-1926	1	1/4"x1" HANDLE GRIP
11	F-1489	4	NUT, 1/2" JAM	30	SEE PAGE 2-7	1	FRONT AXLE WELDMENT
12	F-1936	4	1/2-13 X 3 1/2, 2" THREAD	31	663-089P	1	LATCH PLATE
13	F-1521	7	WASHER, 1/2 NARROW	32	659-170P	1	PLATE, CATCH
14	H-2239	7	RUE RING, 1/2"	33	F-1158	2	NUT, 1/4" STOVER
15	F-1890	2	CLEVIS PIN, 1/2 X 3 1/2"	34	F-1823	2	CARRIAGE BOLT, 1/4-20 X 3/4"
16	F-1898	3	CLEVIS PIN, 1/2 X 2 3/4"	35	F-1005-05	1	1/2" STOVER NUT
17	F-2039	4	5/16-24 x 2" HHCS	36	F-2041	4	5/16-24 JAM NUT
18	642-175P	2	ADJUSTABLE HANGER END	37	F-1828	1	1/2-13 x 3-1/2" CAPSCREW
19	659-171A	1	RELEASE HANDLE ASSEMBLY				

TRANSMISSION IDLERS & RELATED PARTS

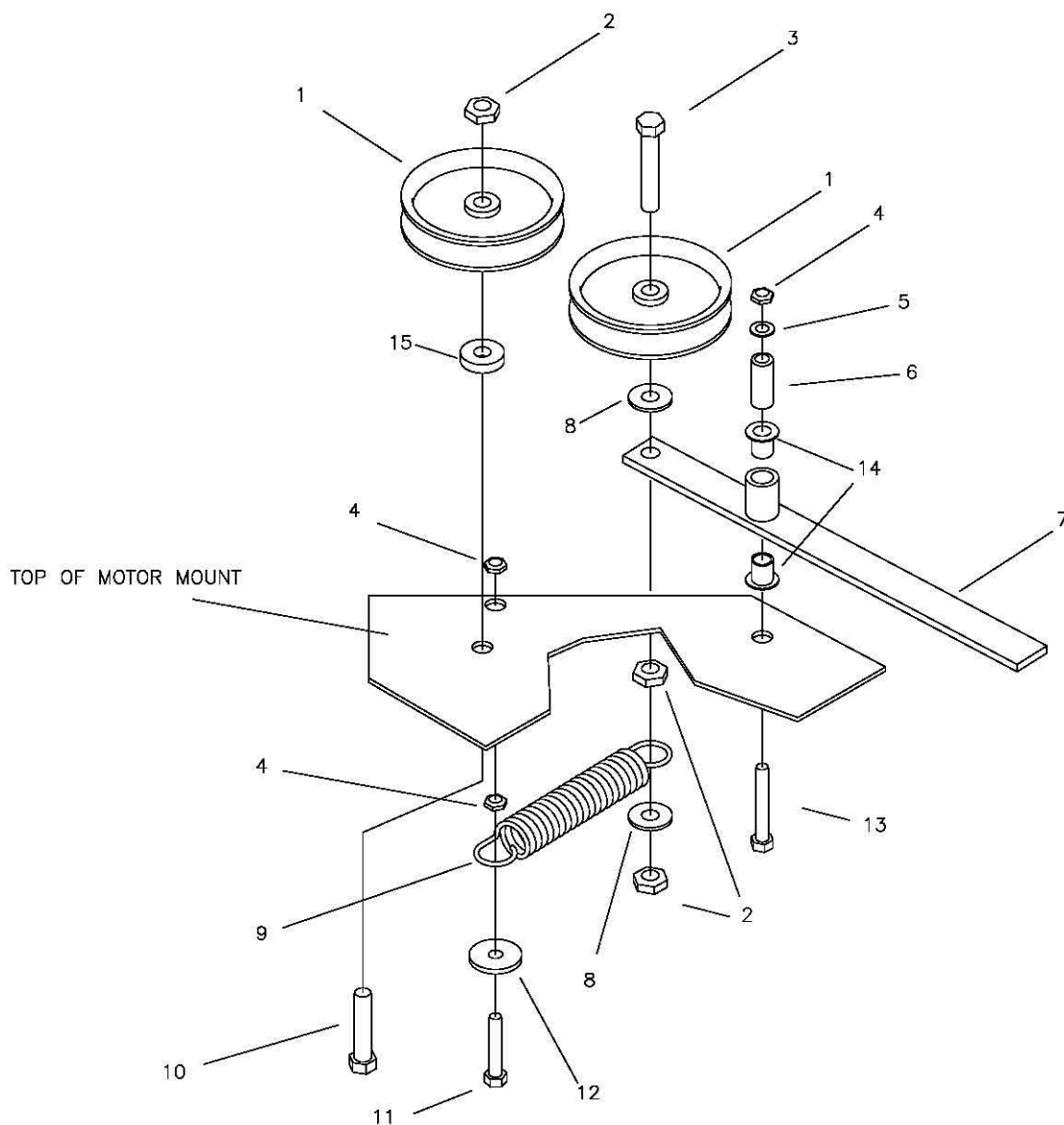

REF NO.	PART NO.	QTY.	DESCRIPTION
1	D-3338	2	4" FLAT IDLER PULLEY
2	F-1005-05	3	1/2-13 STOVER NUT
3	F-1439	1	1/2-13 X 3" BOLT GR. 5
4	F-1005-03	3	3/8-16 STOVER NUT
5	F-1009-03	1	3/8" FLAT WASHER
6	659-085P	1	MOUNTING PIN
7	663-017W	1	HYDRO IDLER ARM WLDT.
8	F-1009-05	2	1/2" FLAT WASHER
9	H-2092	1	1 1/4 X 5" SPRING
10	F-1664	1	1/2-13 X 2 1/4" BOLT GR. 5
11	F-1073	1	3/8-16 X 2" BOLT GR. 5
12	609-034P	1	SPACER
13	F-1015-30	1	3/8-16 X 2 1/2" BOLT GR. 5
14	D-3730	2	BUSHING, 5/8" BORE
15	660-038P	1	3/8" SPACER

CASTER WHEEL ASSEMBLY

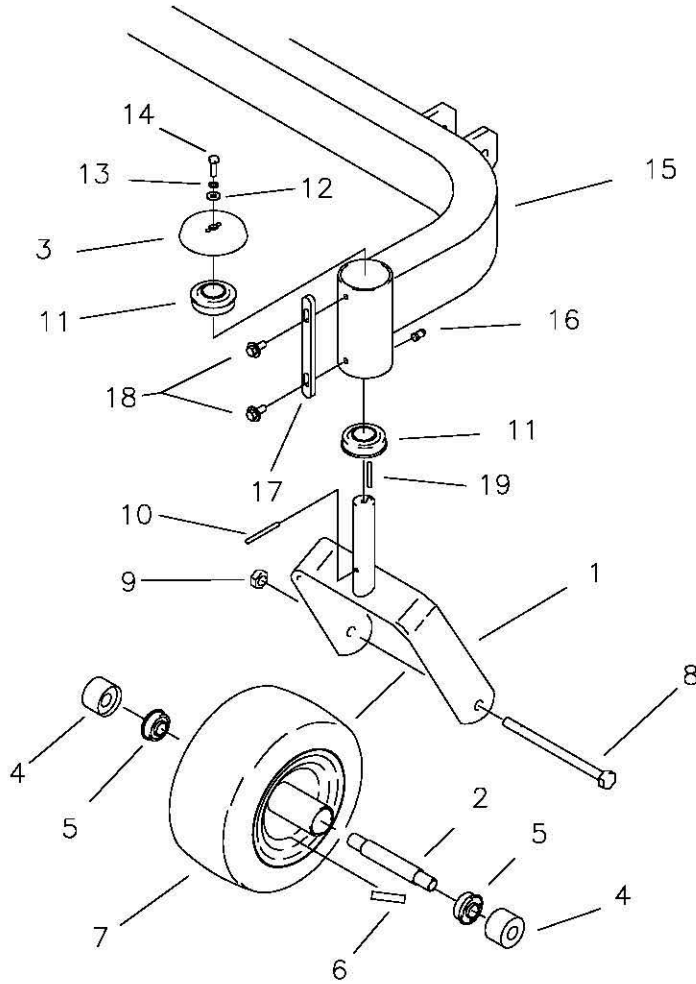

REF NO.	PART NO.	QTY.	DESCRIPTION
1	647-192W	2	CASTER WELDMENT
2	647-038P	2	BEARING SPACER
3	636-177P	2	BEARING CAP
4	611-135P	4	BEARING SHIELD
5	D-3432	4	BEARING, 5/8 ID X 1 3/8 OD
6	P-11384	2	DECAL, 12 PSI
7	D-3670	2	FRONT TIRE/WHEEL
8	F-1908	2	1/2-13 X 6 1/2" GR. 5 BOLT
9	F-1005-05	2	1/2-13 LOCK NUT
10	F-1456	2	3/16 ROLL PIN
11	D-2008-02	4	BEARING, SPD SF-16-32
12	F-1009-01	2	1/4" FLAT WASHER
13	F-1019-01	2	1/4" LOCK WASHER
14	F-1810	2	1/4-20 X 3/4 W/NYLON PATCH
15	642-189W	1	FRONT AXLE WELDMENT
16	H-1056	2	GREASE ZERK
17	659-187P	2	STOP TAB
18	F-2030	4	1/4" X 5/8" SELF TAPPING SCREW
19	F-1855	2	3/16" X 1" ROLL PIN

FRAME SIDES & RELATED PARTS

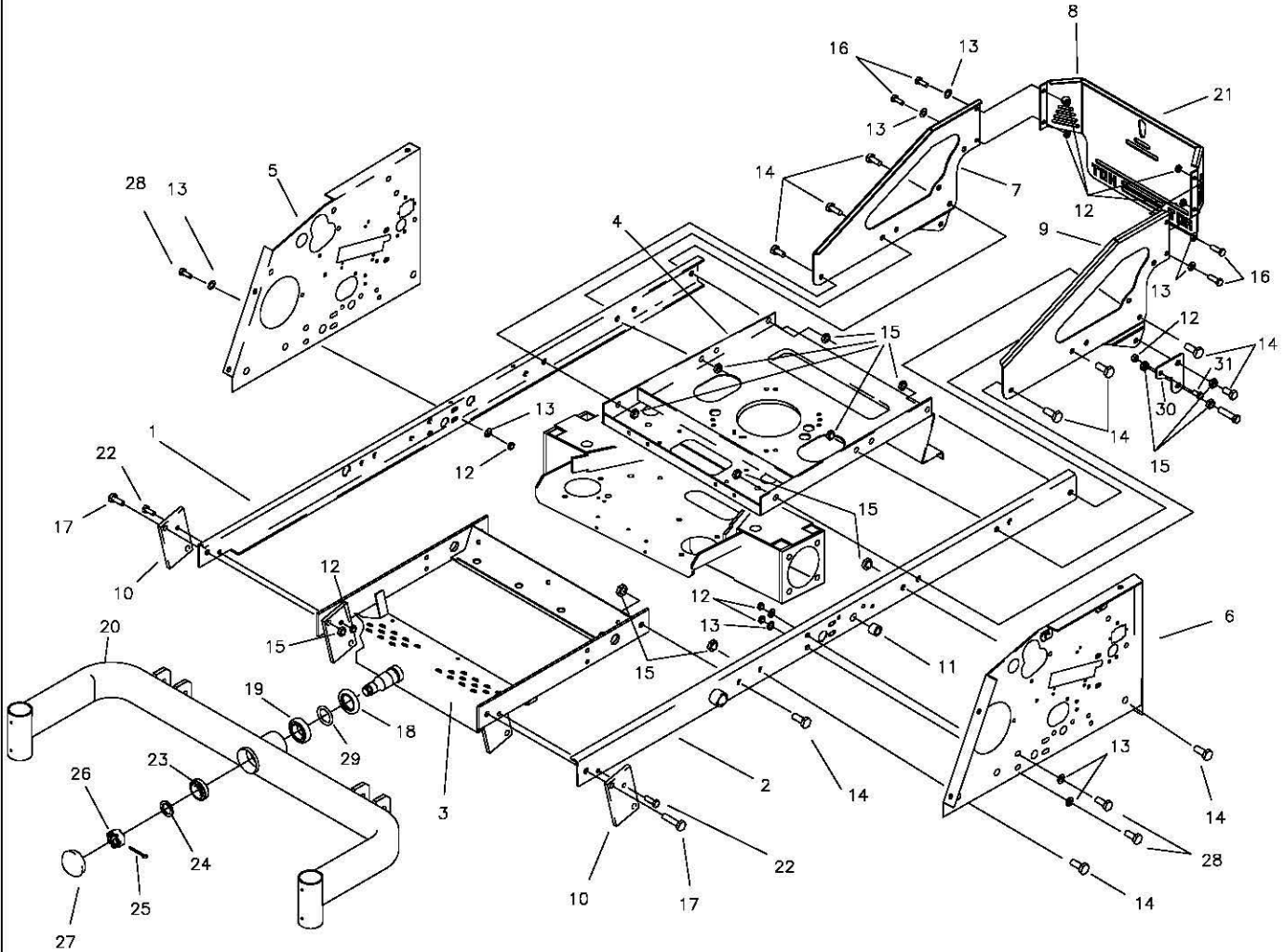

REF NO.	PART NO.	QTY.	DESCRIPTION	REF NO.	PART NO.	QTY.	DESCRIPTION
1	659-021W	1	FRAME SIDE RH.	17	F-1293	2	1/2-13 X 2", GR.5
2	659-022W	1	FRAME SIDE LH.	18	H-2600	1	SEAL SHAFT
3	663-094W	1	AXLE MOUNTING WLDT.	19	D-3825	1	BEARING, TAPARED SET
4	663-070W	1	MOTOR MOUNT WLDT.	20	SEE PAGE 2-7	1	FRONT AXLE WELDMENT
5	659-209W	1	SIDE PANEL RH.	21	P-12097	1	COLORED DECAL, "COUNTRY CLIPPER"
6	659-202P	1	SIDE PANEL LH.	22	F-1015-28	2	3/8-16 X 1-3/4" CAPSCREW
7	659-133P	1	RH ENGINE SIDE PANEL	23	D-3826	1	BEARING, TAPARED SET
8	647-120P	1	REAR PANEL GUARD	24	606-303P	1	1" WASHER
9	659-134P	1	LH ENGINE SIDE PANEL	25	F-1728	1	3/16 X 2" COTTER PIN
10	642-063P	2	DRAG BAR TAB	26	F-1724	1	1-14 SLOTTED NUT
11	D-3730	2	BUSHING, 5/8 BORE(JOYSTICK)	27	H-1924	1	GREASE CAP
12	F-1005-03	11	3/8-16 STOVER NUT	28	F-1307	4	3/8-16 X 1-1/4" CAPSCREW
13	F-1009-03	16	3/8 FLAT WASHER	29	663-074P	1	RING, BACK-UP, STEEL
14	F-1759	13	1/2-13 X 1" GR.5	30	663-104P	1	PLATE, SPRING MOUNT
15	F-1005-05	19	1/2-13 LOCK NUT	31	F-1015-23	1	3/8-16 X 3/4" CAPSCREW
16	F-1558	4	3/8-16 X 7/8" GR.5				

FENDER ASSEMBLY

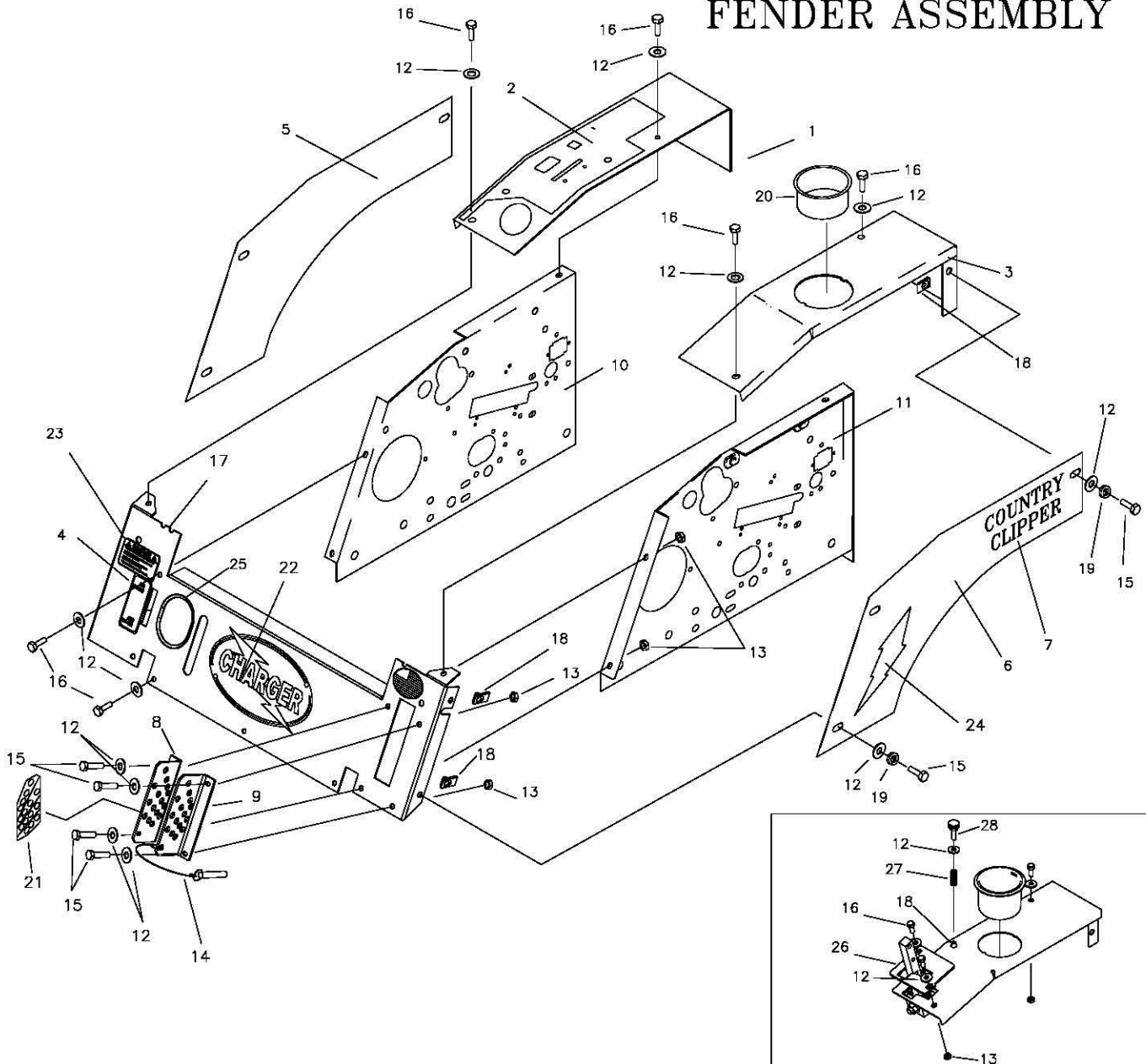

TWINSTICK FENDER ASSY

REF NO.	PART NO.	QTY.	DESCRIPTION	REF NO.	PART NO.	QTY.	DESCRIPTION
1	663-060A	1	FENDER CAP RH W/DECAL	14	F-2028	1	LOCK PIN 1/2 x 3"
-	663-061A	1	FENDER CAP, TWIN STK. RH W/DECAL	15	F-1015-15	8	5/16-18 X 1" GR.5
2	P-11626	1	DECAL, "CONTROL PANEL"	16	F-1546	9	5/16-18 X 3/4" GR.5
-	P-12688	1	DECAL, "CONTROL PANEL" TWIN STK RH	17	663-103P	1	FRONT PANEL W/DECALS
3	663-105P	1	FENDER CAP LH.	18	F-1860	7	5/16 U-NUT
-	663-076P	1	FENDER CAP, TWIN STK. LH.	19	F-1019-02	6	5/16 LOCK WASHER
4	P-11382	1	DECAL, PARK BRAKE	20	H-2228	1	CUP HOLDER
5	663-053A	1	FENDER SKIRT RH W/DECALS	21	P-12034	1	DECAL, "CUT HEIGHT"
6	663-054A	1	FENDER SKIRT LH W/DECALS	22	P-11832	1	DECAL, "CHARGER"
7	P-12098	2	DECAL, COUNTRY CLIPPER, SMALL	23	P-12557	1	DECAL, "CAUTION"
8	647-097A	1	LATCH PLATE RH W/DECAL	24	P-12382	1	DECAL, "LIGHTING BOLTS"
9	647-095P	1	LATCH PLATE LH.	25	H-1626	1	U CHANNEL TRIM
10	659-209W	1	SIDE PANEL RH.	26	659-262P	1	NEUTRAL PLATE
11	659-202P	1	SIDE PANEL LH.	27	H-1776	1	SPRING
12	F-1009-02	24	5/16 FLAT WASHER	28	F-2081	1	KNOB
13	F-1125	8	5/16-18 LOCK NUT				

SEAT, FOOTDECK & RELATED PARTS

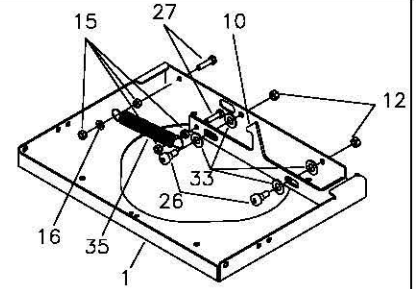

UNDERSIDE OF SEAT MOUNTING BASE "#1" - LATCH PARTS

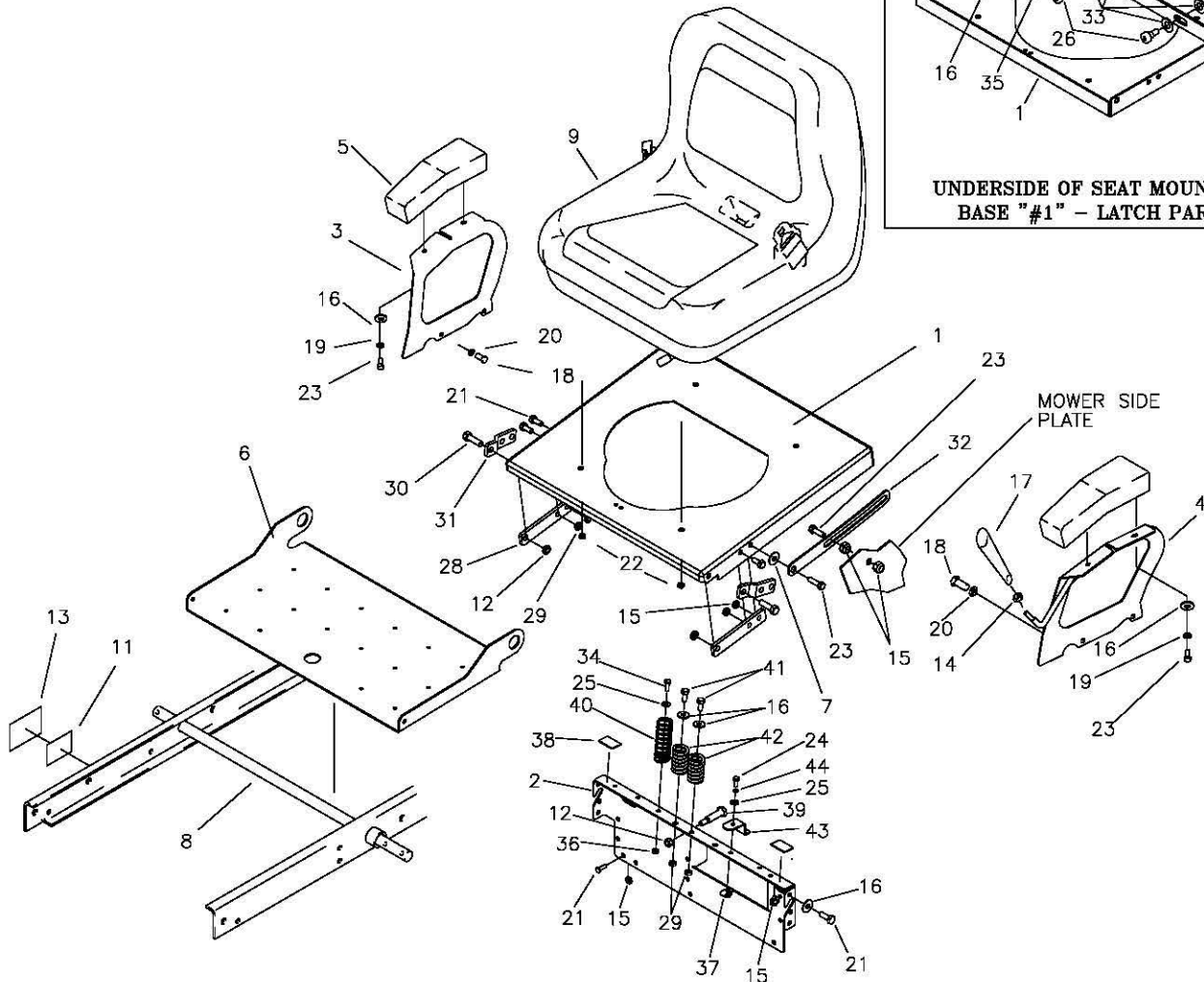

REF NO.	PART NO.	QTY.	DESCRIPTION	REF NO.	PART NO.	QTY.	DESCRIPTION
1	663-082P	1	SEAT MOUNTING BASE	22	F-2063	4	3/8-16 NYLOC NUT, FLANGED
2	663-010P	1	REAR SEAT BRACE	23	F-1015-15	6	5/16-18 X 1" GR. 5
3	659-266P	1	ARM REST RH. (JOYSTICK)	24	F-1015-02	1	1/4-20 X 5/8", GR.5
-	663-085P	1	ARM REST RH, (TWINSTICK)	25	F-1009-01	2	1/4" FLAT WASHER
4	659-268W	1	ARM REST LH. (JOYSTICK)	26	F-2062	2	1/2"x3/8 SHOULDER BOLT, SOCKET
-	663-086P	1	ARM REST LH, (TWINSTICK)	27	F-1175	2	1/4-20 X 1 1/4", GR.5
5	H-2615	2	ARM REST PAD	28	659-175P	2	SEAT HINGE TAB
6	659-307P	1	FOOT DECK	29	F-1125	4	5/16-18 STOVER NUT
7	659-274P	1	PIVOT WASHER	30	F-1307	2	3/8-16 X 1 1/4" CAPSCREW
8	620-051P	1	LIFT BAR	31	647-086P	2	FLIP SEAT MATING TAB
9	H-2686	1	SEAT	32	659-272P	1	SEAT STOP BAR
10	663-081P	1	PLATE, LATCH SLIDE LONG	33	F-1521	4	1/2" WASHER
11	P-12689	1	SERIAL TAG	34	F-1538	1	1/4-20x3/4" CAPSCREW
12	F-1005-03	6	3/8-16 LOCK NUT	35	H-1635	1	3/4x4" EXTENSION SPRING
13	P-12473	1	SERIAL TAG LAMINATION DECAL	36	F-1005-01	1	1/4-20 STOVER NUT
14	F-1486	1	3/8-16 JAM NUT	37	F-1858	1	1/4-20 "U" NUT
15	F-1005-02	18	5/16-18 LOCK NUT	38	H-2668	2	CHARGER SEAT BASE PAD
16	F-1009-02	9	5/16 FLAT WASHER	39	F-2061	1	1/2"x1 1/2" SHOULDER BOLT
17	H-2317	1	TAPERED HANDLE (JOYSTICK)	40	H2608	1	SPRING, ASSIST
18	F-1015-23	4	3/8-16 X 3/4" GR. 5	41	F-1546	2	5/16-18x3/4" CAPSCREW
19	F-1019-02	4	5/16 LOCK WASHER	42	H-2636	2	SPRING, CMPR, SEAT CHARGER
20	F-1019-03	4	3/8 LOCK WASHER	43	659-137P	1	BATTERY HOLD DOWN
21	F-1546	11	5/16-18 X 3/4" GR. 5	44	F-1019-01	1	1/4" LOCK WASHER

FRONT STEP ASSEMBLY

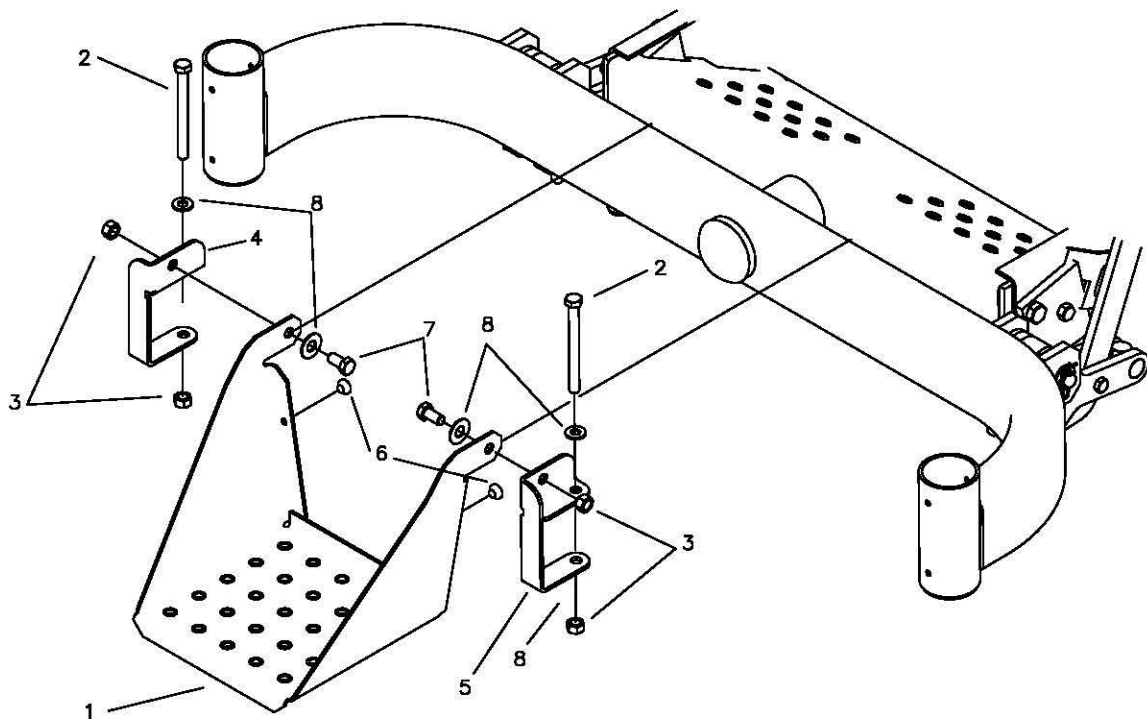

REF NO.	PART NO.	QTY.	DESCRIPTION
1	647-133P	1	FRONT STEP
2	F-1066	2	3/8-16 X 4" CAPSCREW
3	F-1005-03	4	3/8-16 LOCK NUT
4	659-241P	1	BRACKET, STEP MOUNT, RH
5	659-242P	1	BRACKET, STEP MOUNT, LH
6	H-2461	2	RUBBER BUMPER BUTTON
7	F-1015-23	2	3/8-16 X 3/4" HEX HEAD BOLT
8	F-1009-03	4	3/8" FLAT WASHER

ROPS ASSEMBLY (H-2682) AND RELATED PARTS

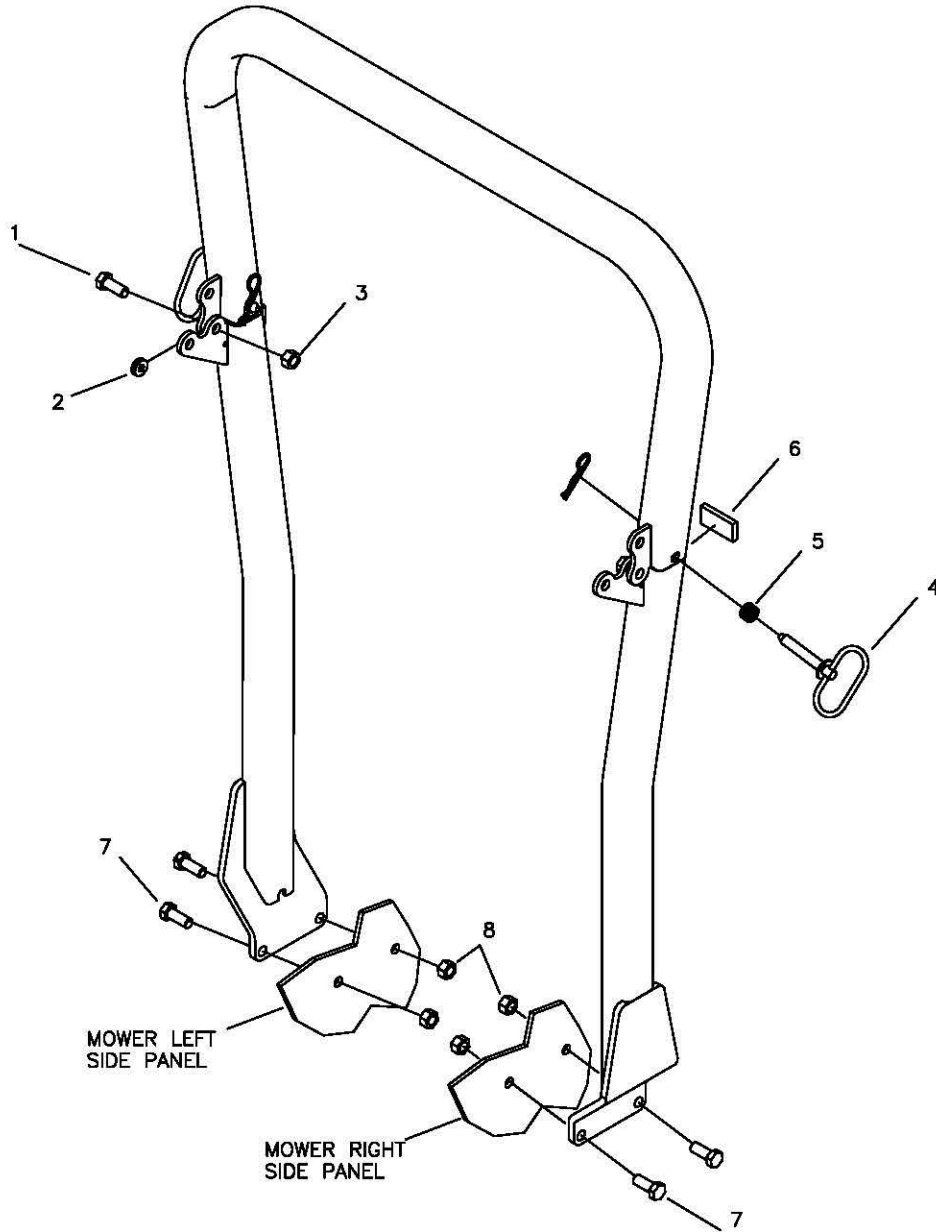

REF NO.	PART NO.	QTY.	DESCRIPTION
1	F-2088	2	HHCS 1/2-13 x 1 1/4"
2	F-2089	2	FLAT WASHER 1/2"φ
3	F-2090	2	TOP LOCK NUT 1/2"φ
4	F-2093	2	PULL PIN-1/2 W/COTTER KEY
5	H-2701	2	SPRING
6	H-2700	2	POLYURETHANE CHANNEL
7	F-2091	4	HHCS 1/2-13 x 1 1/2"
8	F-2092	4	NLN 1/2-13 GR 8

FUEL TANK ASSEMBLY 663-107A

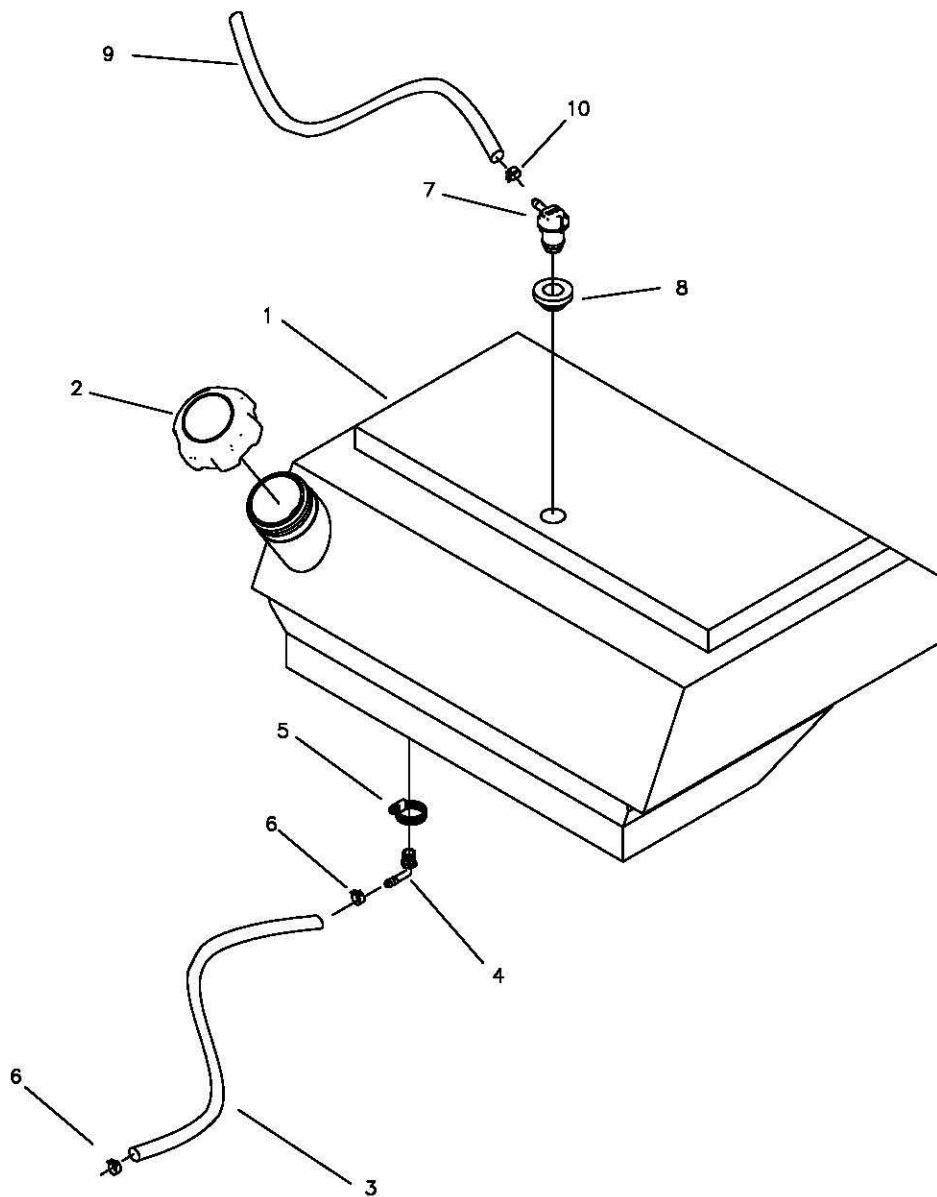

REF NO.	PART NO.	QTY.	DESCRIPTION
1	H-2680	1	8 GALLON TANK, VENTED
2	H-2687	1	GAS CAP, RATCHET
3	H-1648	1	FUEL LINE
4	H-1646	1	HOSE BARB, 90 DEG.
5	H-1952	1	HOSE CLAMP
6	H-1687	2	HOSE CLAMP, 1/2"
7	H-2678	1	REMOTE VENT
8	H-2679	1	REMOTE VENT GROMMET
9	H-2697	1	VENT LINE
10	H-2698	2	VENT LINE CLAMP

JOYSTICK STEERING CONTROL AND RELATED PARTS

NOTE: ITEM'S #2 AND #3 MUST BE REPLACED AT THE SAME TIME FOR MAXIMUM PERFORMANCE.

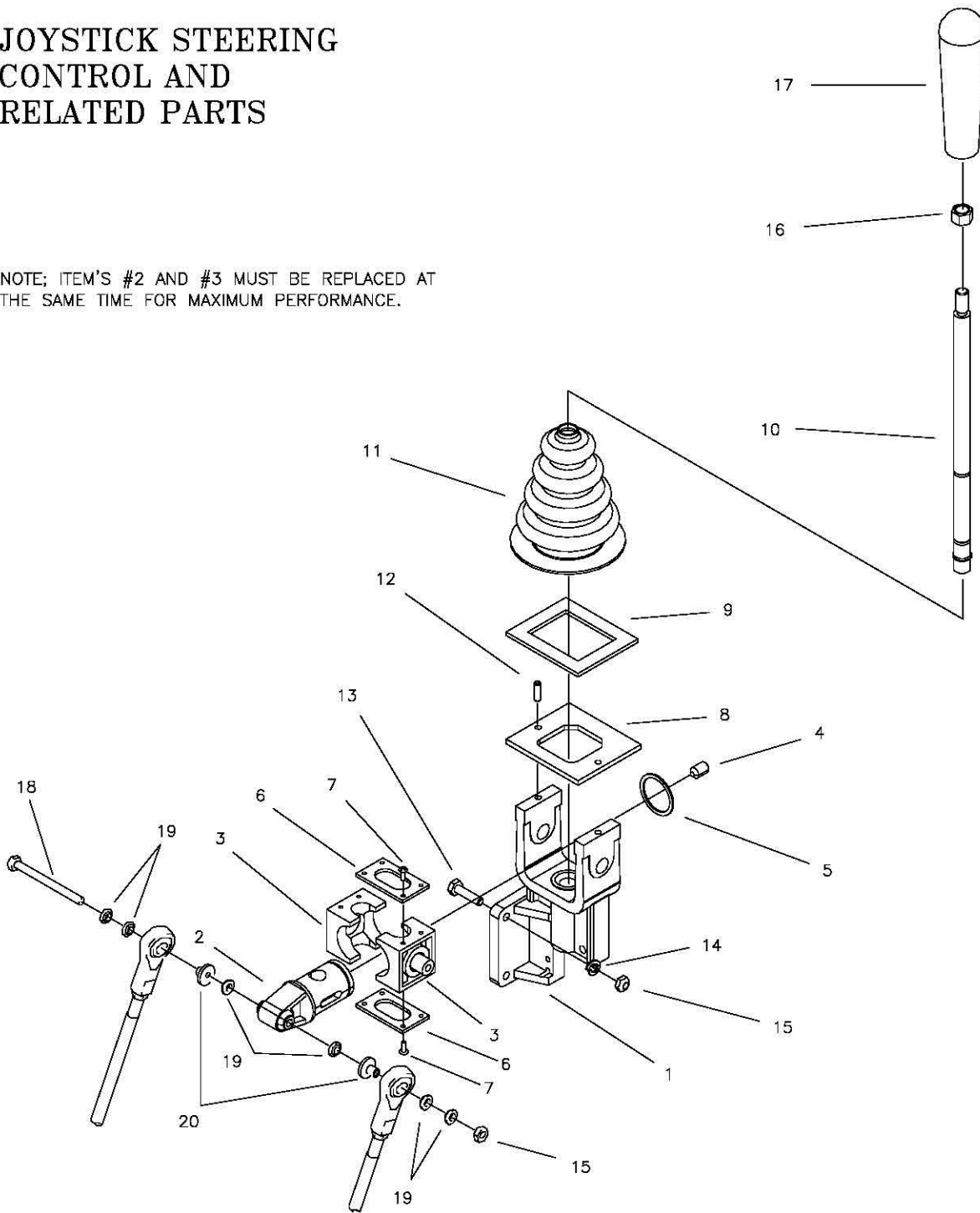

REF NO.	PART NO.	QTY.	DESCRIPTION	REF NO.	PART NO.	QTY.	DESCRIPTION
—	647-122A	1	JOYSTICK ASSEMBLY	11	H-1991	1	BOOT, BELLOWS
1	659-144P	1	JOYSTICK YOKE	12	F-1999	2	ROLL PIN, 3/16 X 5/8
2	H-1992	1	PIVOT SHAFT	13	F-1015-05	3	1/4-20 X 1" HHCS GR. 5
3	H-1993	2	PIVOT BLOCK	14	F-1019-01	3	1/4" LOCK WASHER
4	F-1120	1	BALL PLUNGER	15	F-1158	4	1/4-20 LOCK NUT
5	H-1997	1	SNAP RING, SPIRLOCK	16	F-1011-03	1	3/8-16 NUT, JAM
6	619-306P	2	PIVOT BLOCK PLATE	17	H-2317	1	GRIP, HANDLE
7	F-1624	8	#6-32 X 3/8" SCREW SLOT	18	F-1020-01	1	1/2-20 X 3-1/2" GR. 5
8	659-129P	1	JOYSTICK TOP PLATE	19	H-1989	6	BUSHING, BALL JOINT
9	H-1947	1	GASKET, FOAM	20	H-2465	2	1/4" SPACER
10	621-140A	1	JOYSTICK SHAFT ASSEMBLY				

JOYSTICK STEERING CONTROL AND RELATED PARTS (CONTINUED)

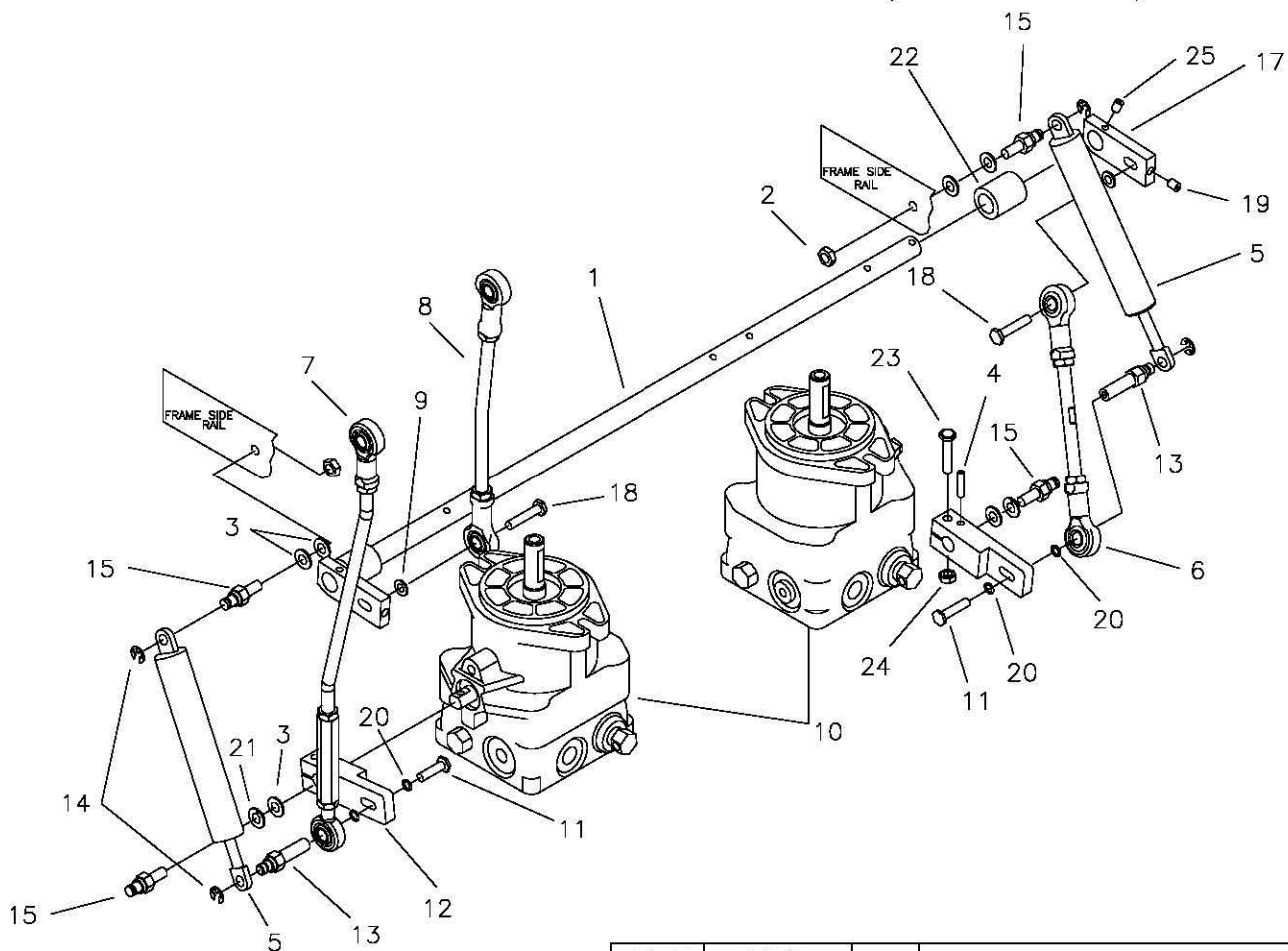

REF NO.	PART NO.	QTY.	DESCRIPTION
1	659-026P	1	HYDRO SHIFT ROD
2	F-1125	2	5/16" STOVER NUT
3	F-1009-02	6	5/16" FLAT WASHER
4	F-1553	2	3/16 X 7/8" SPIRAL PIN
5	H-2467	2	DUAL ACTION DAMPER, LITE DUTY
6	659-114P	1	LOWER LINKAGE
7	663-050P	1	STEERING LINKAGE ASSEMBLY
8	663-049P	1	STEERING LINKAGE ASSEMBLY
9	F-1009-03	2	3/8" FLAT WASHER
10	----	-	SEE PAGE 3-19
11	F-1015-05	2	1/4-20 X 1" BOLT GR 5
12	663-022P	2	SHIFT ARM
13	663-051P	2	DAMPNER BOLT, FEMALE
14	F-1610	4	E-RING
15	638-028P	4	5/16-18 X 3/4" DAMPNER BOLT
16	H-2465	2	1/4 X 5/16 SHOULDER WASHER
17	625-091A	2	SWIVEL ARM
18	F-1394	2	3/8-16 X 1" CAPSCREW
19	F-1695	2	1/4-20 SETSCREW
20	F-1019-01	4	1/4" LOCK WASHER
21	F-1019-02	2	5/16" LOCK WASHER
22	651-024P	2	SPACER
23	F-1539	2	1/4-20 x 1 1/4" CAPSCREW
24	F-1158	2	1/4-20 STOVER NUT
25	F-2080	2	5/16-18 SETSCREW

STEERING CONTROL AND RELATED PARTS

(RIGHTHAND SHOWN LEFTHAND OPPOSITE)

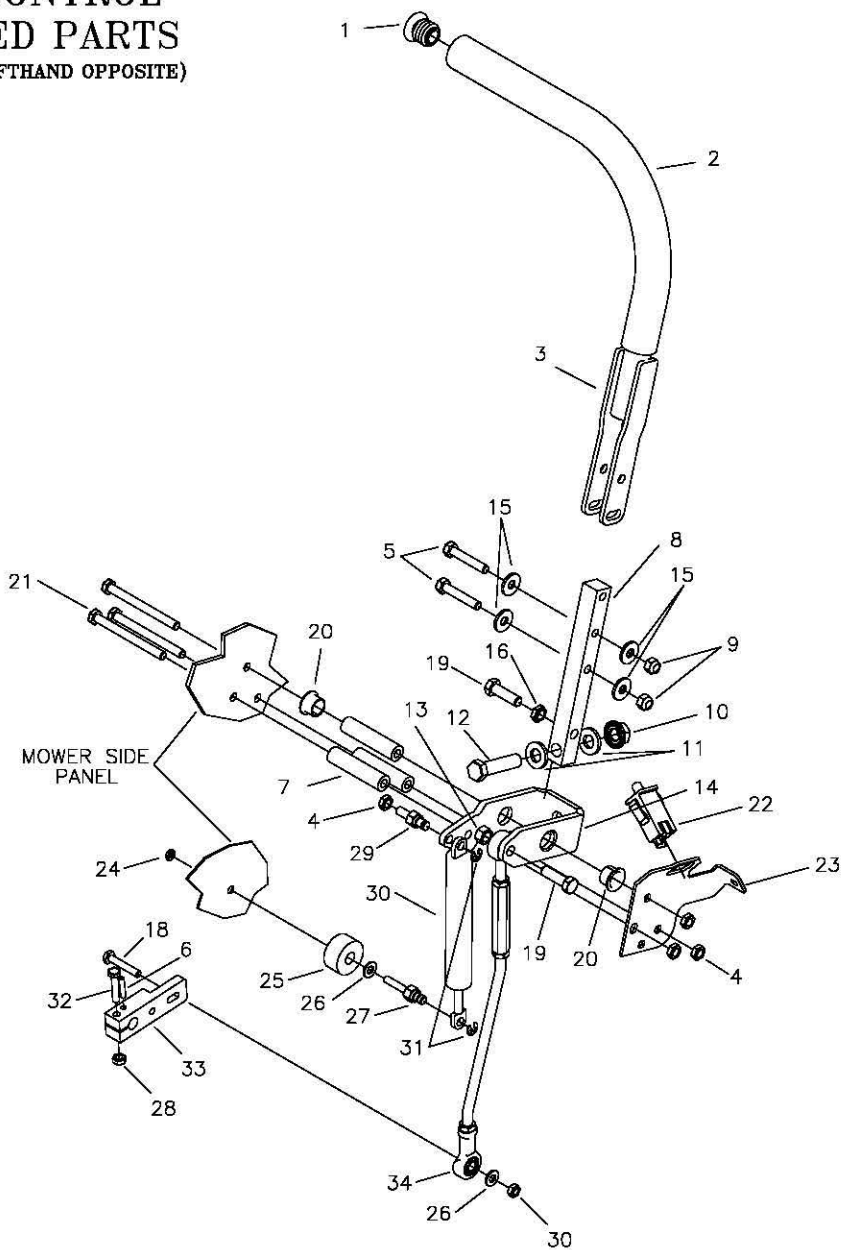

REF NO.	PART NO.	QTY.	DESCRIPTION	REF NO.	PART NO.	QTY.	DESCRIPTION
1	H-2080	2	END PLUG, 15/16" BLACK	19	F-1307	4	3/8-16 X 1 1/4" CAPSCREW
2	H-2079	2	FOAM GRIP, 17"	20	D-3730	4	FLANGED BUSHING 5/8" BORE
3	659-249W	2	DUAL LEVER CONTROL	21	F-2058	6	5/16-18 x 3 1/2" CAPSCREW
4	F-1125	3	5/16 LOCK NUT	22	E-6474	2	SWITCH, SNAP MOUNT
5	F-1015-18	4	5/16-18 X 1 3/4" CAPSCREW	23	659-244P-A	1	MOUNTING BRACKET (RH)
6	F-1553	2	3/16 x 7/8" SPIRAL PIN	--	659-245P-A	1	MOUNTING BRACKET (LH)
7	659-252P	6	TUBE SPACER	24	F-1158	2	1/4-20 STOVER NUT
8	659-247P	1	LOWER SHIFT BLOCK	25	F-2045	2	SPACER
9	F-1005-02	4	5/16-18 NYLOC NUT	26	F-1009-01	4	1/4" FLAT WASHER
10	F-2060	2	1/2-13 NUT, FLANGE LOCK	27	638-029P	2	DAMPER BOLT, 1/4-20
11	606-151P	4	WASHER, NYLON 1/2 ID x 1/8"	28	F-1158	3	1/4-20 LOCK NUT
12	F-1293	2	1/2-13 x 2" CAPSCREW	29	638-028P	2	DAMPER BOLT, 5/16-18 x 3/4"
13	F-1005-03	2	3/8-16 STOVER NUT	30	H-2467	1	DUAL ACTION DAMPNER
14	659-243P	2	SHIFTING YOKE	31	F-1610	2	E-RING FOR 1/4" SHAFT
15	F-1009-02	8	WASHER, FLAT STD. 5/16"	32	F-1539	3	1/4-20 X 1-1/4" HHCS GR. 5
16	F-1486	2	3/8-16 JAM NUT	33	663-022P	1	SHIFT ARM
17	F-1019-01	4	1/4" LOCK WASHER	34	663-050P	1	LINK ROD ASSEMBLY
18	F-1015-05	1	1/4-20 X 1" HHCS GR. 5				

PARKING BRAKE ASSEMBLY & RELATED PARTS

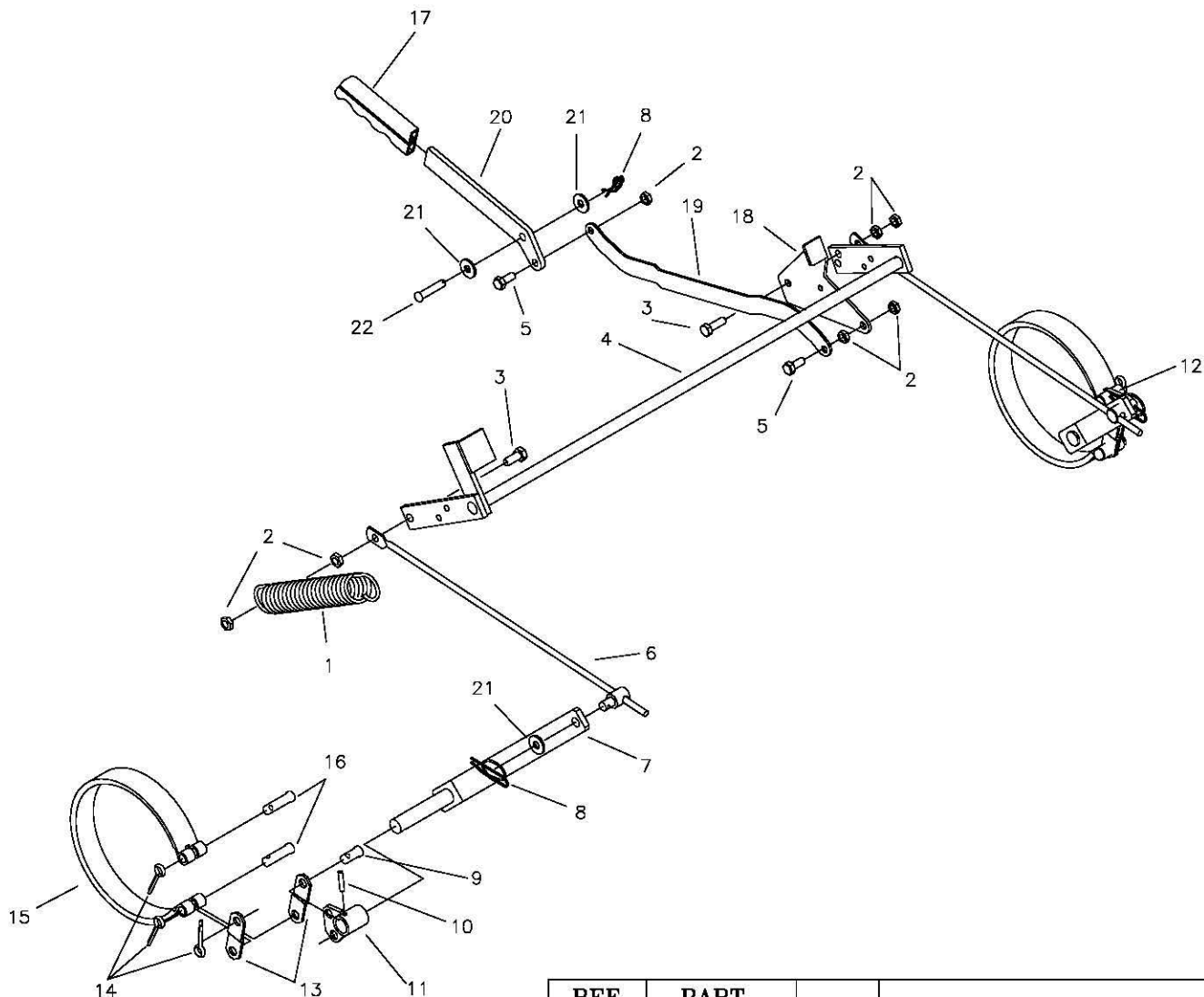

REF NO.	PART NO.	QTY.	DESCRIPTION
1	H-1635	1	3/4 X 4" SPRING
2	F-1125	7	5/16-18 STOVER NUT
3	F-1015-15	2	5/16-18 X 1" BOLT
4	663-078W	1	BRAKE ROD WLDT
5	F-1546	2	5/16-18 X 3/4" BOLT
6	H-2451	2	BRAKE LINK ROD ASSEMBLY
7	647-013W	2	BRAKE ARM WLDT
8	F-1492	2	5/16 X 3/8" RUE RING
9	F-1438	2	3/8 X 3/4" CLEVIS PIN
10	F-1553	2	5/16 X 7/8" ROLL PIN
11	647-029W	1	SHORT BRAKE ARM (LH)
12	647-028W	1	SHORT BRAKE ARM (RH)
13	647-010P	4	BRAKE ANCHOR LINK
14	F-1491	6	1/8 X 1" COTTER PIN
15	D-3668	2	BRAKE BAND 6" X 1" WIDE
16	F-1444	4	3/8 X 1 5/16" CLEVIS PIN
17	H-1926	1	GRIP HANDLE
18	663-106P	1	BRAKE SWITCH STOP
19	659-203P	1	BRAKE LINK
20	659-308P	1	BRAKE HANDLE, FLAT
21	F1009-02	3	5/16" FLAT WASHER
22	F-1533	1	5/16 x 1 1/2" CLEVIS PIN

GEAR MOTOR, WHEEL ASSEMBLY

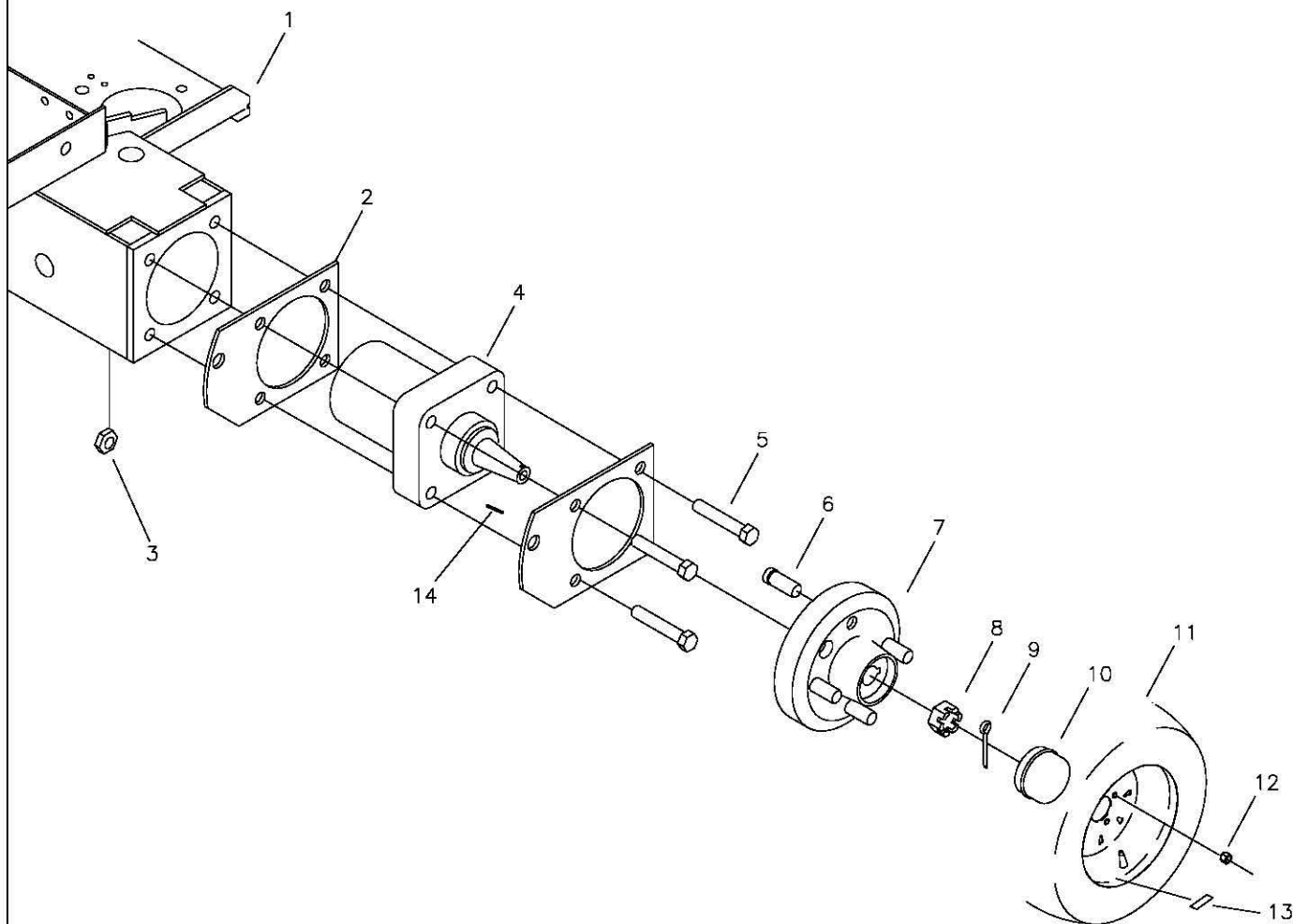

REF NO.	PART NO.	QTY.	DESCRIPTION
1	663-070W	1	MOTOR MOUNT
2	647-017P	4	BRAKE MOUNT
3	F-1005-05	8	1/2-13 STOVER NUT
4	D-3667	2	WHEEL MOTOR PARKER "TE" SERIES
5	F-1668	8	1/2-13 X 2 3/4" BOLT GR. 5
6	F-1654	8	WHEEL STUD (REPLACEMENT)
7	647-041P	2	WHEEL HUB
8	F-1909	2	3/4-16 CASTLE NUT
9	F-1396	2	1/8 X 1 1/2" COTTER PIN
10	H-1798	1	GREASE CAP
11	D-3669	2	TIRE/WHEEL ASSEMBLY
12	F-1499	8	LUG NUT 1/2-20 X 60 DEG.
13	P-11384	1	DECAL, 12 PSI
14	D-1004-01	2	1/4 X 1" KEY

MOTOR ASSEMBLY & RELATED PARTS

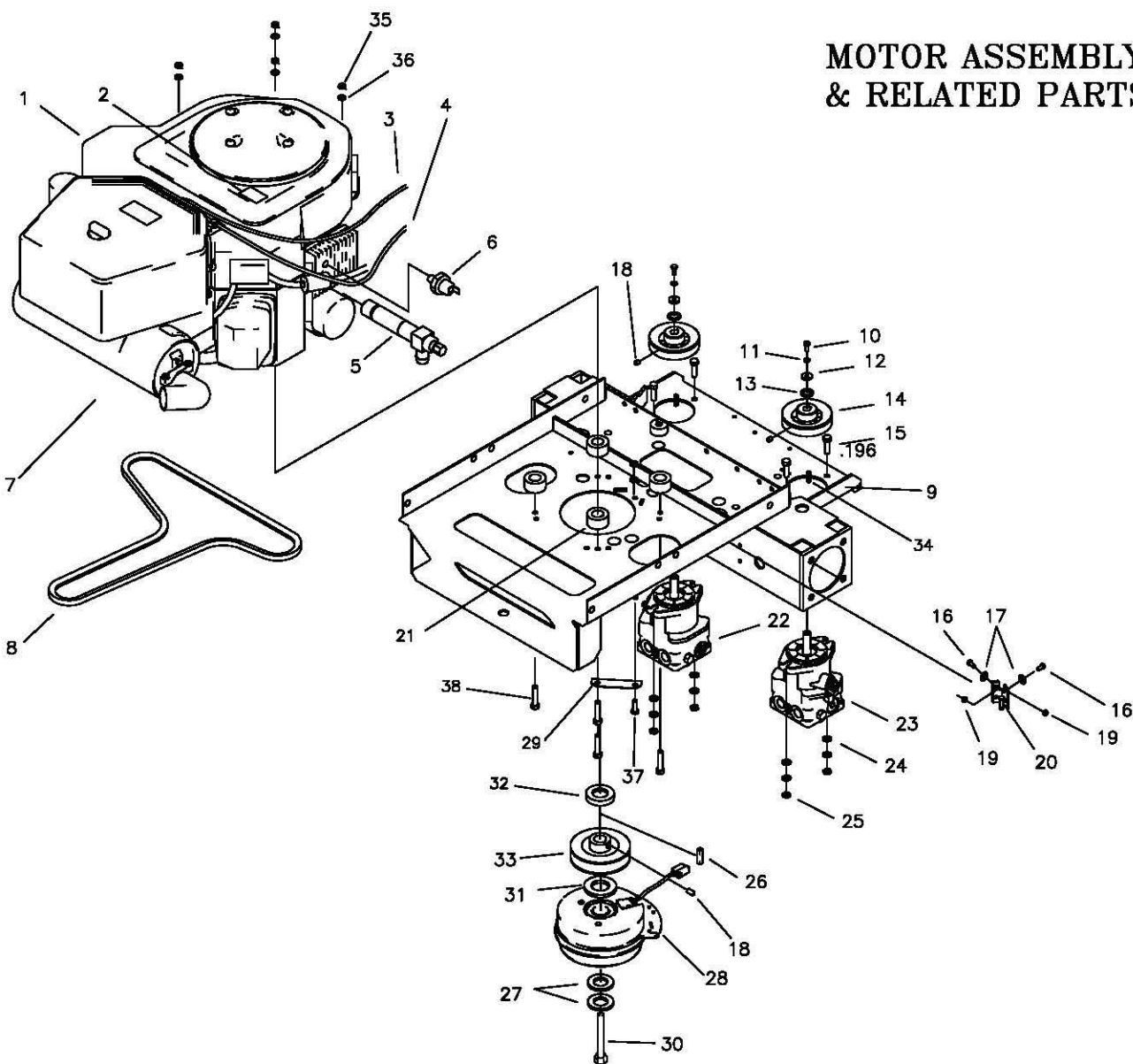

REF NO.	PART NO.	QTY.	DESCRIPTION	REF NO.	PART NO.	QTY.	DESCRIPTION
1	M-5325	1	23 HP. KOHLER ENGINE	20	659-015W	1	CLUTCH STOP WELDMENT
-	M-5376	1	26 HP. KAWASAKI ENGINE	21	H-2045	4	SPACER (26HP KAWASAKI)
-	M-5335	1	27 HP. KOHLER ENGINE	22	D-3770-02	1	HYDRO PUMP (RH)
2	P-10077	1	DECAL, "CLEAN"	23	D-3770-01	1	HYDRO PUMP (LH)
3	H-2235	1	CHOKE CABLE (26HP KAWASAKI)	24	F-1009-03	8	3/8" FLAT WASHER
-	H-2404	1	CHOKE CABLE(23HP & 27HP KOHLER)	25	F-1005-03	4	3/8-16 STOVER NUT
4	H-2610	1	THROTTLE CABLE	26	621-113P	1	KEY, 1/4" SQ. X 1 1/4"
5	H-2589	1	OIL DRAIN (23HP & 27HP KOHLER)	27	606-347P	2	15/32" I.D. WASHER
-	H-2590	1	OIL DRAIN (26HP KAWASAKI)	28	E-6247	1	1 1/8" CLUTCH BRAKE
6	E-6307	1	OIL PRESSURE SWITCH (23HP & 26HP)	29	647-085P	1	GROUND STRAP (26HP KAWASAKI)
7	H-2607	1	MUFFLER ASSEMBLY (KAWASAKI)	30	F-1766	1	7/16-20 X 3-1/4" BOLT GR. 5
8	D-3769	1	V-BELT A-67 KEVLAR	31	611-143P	1	1 1/8" 10 GA. WASHER
9	663-070W	1	MOTOR MOUNT	32	F-2043	1	SPACER (26HP KAWASAKI)
10	F-1737	2	6mm X 16mm BOLT GR. 5	33	647-036P	1	MOTOR PULLEY
11	F-1738	2	6mm SPRING WASHER	34	D-3541	2	KEY - 5mm x 20mm
12	F-1736	2	WASHER, .840 X .246 X .125	35	F-1125	4	5/16-18 STOVERNUT(23HP&27HP KOHLER)
13	663-046P	2	WASHER, SPACER	--	F-1005-03	4	3/8-16 STOVER NUT (26HP KAWASAKI)
14	647-035P	2	HYDRO PUMP PULLEY	36	F-1019-02	4	5/16" LOCK WASHER(23HP&27HP KOHLER)
15	F-1307	4	3/8-16 X 1 1/4" BOLT GR. 5	--	F-1019-03	4	3/8" LOCK WASHER (26HP KAWASAKI)
16	F-1015-02	2	1/4-20 X 5/8" BOLT GR. 5	37	F-1015-15	1	5/16-18x1" CAPSCREW (26HP KAWASAKI)
17	F-1009-01	2	1/4" FLAT WASHER	38	F-1015-17	4	5/16-18x1 1/2" (23HP&27HP KOHLER)
18	F-1228	2	1/4-20 NYLOC SETSCREW	--	F-1015-28	4	3/8-16 x 1 3/4" (26HP KAWASAKI)
19	F-1158	2	1/4-20 STOVER NUT				

HIGH PRESSURE LINES & FITTINGS

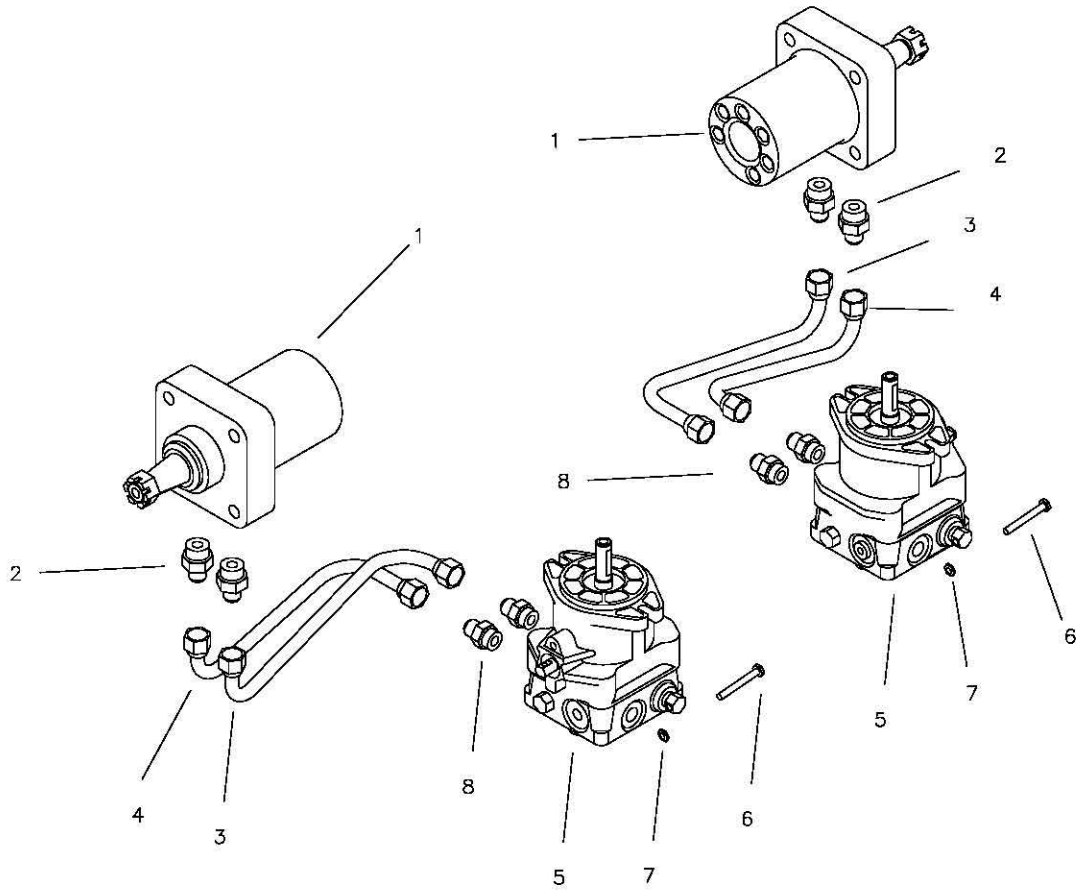

VIEWED FROM FRONT RIGHT

REF NO.	PART NO.	QTY.	DESCRIPTION
1	D-3667	2	WHEEL MOTOR PARKER "TE" SERIES
2	H-2319	4	FITTING, STRIGHT, 7/8-14
3	H-2491	2	TUBE ASS'Y, LH. FORWARD
4	H-2492	2	TUBE ASS'Y, LH. REVERSE
5	-----	-	SEE PAGE 3-19
6	F-1015-09	2	1/4-20 X 2" BOLT GR. 5
7	F-1158	2	1/4-20 STOVER NUT
8	H-2436	4	FITTING, STRAIGHT, 3/4" X 1/2"

OIL RETURN LINES & COOLER ASSEMBLY

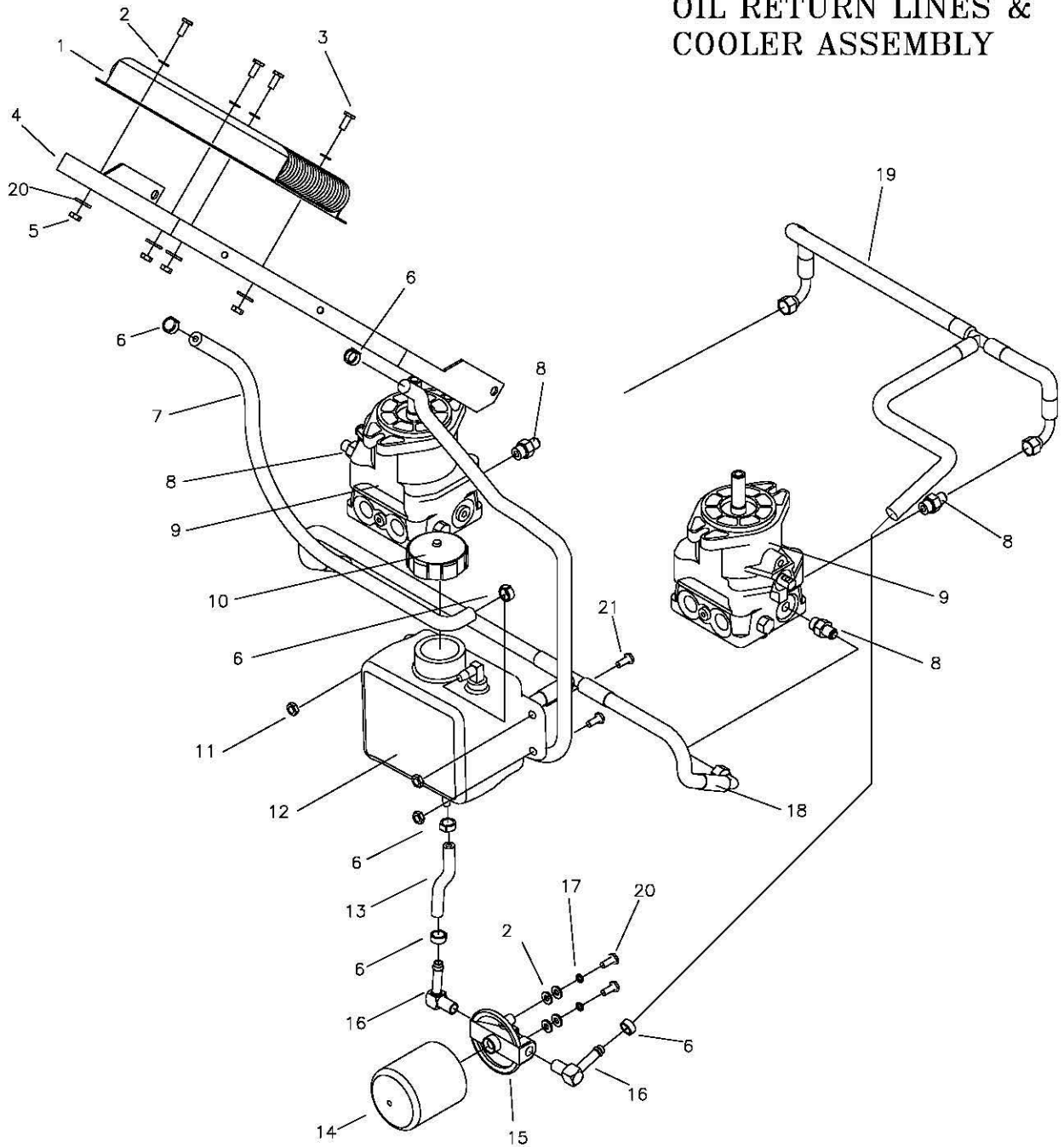

REF NO.	PART NO.	QTY.	DESCRIPTION	REF NO.	PART NO.	QTY.	DESCRIPTION
1	H-2325	1	OIL COOLER	13	H-2437	1	4 1/4" HOSE, 3/8 id. HI TEMP.
2	F-1009-01	8	1/4" WASHER	14	H-2026	1	OIL FILTER
3	F-1015-02	4	1/4-20 X 5/8" BOLT GR. 5	15	H-2061	1	FILTER BASE
4	647-046W	1	OIL COOLER BRACKET	16	H-1859	2	HOSE BARB 90 DEG. ELBOW
5	F-1158	4	1/4-20 STOVER NUT	17	F-1019-01	2	1/4" LOCK WASHER
6	H-2282	6	HOSE CLAMP	18	H-2440	1	RETURN HOSE TEE ASSEMBLY
7	H-2438	1	24" HOSE, 3/8" ID. HI TEMP.	19	H-2439	1	SUCTION HOSE TEE ASSEMBLY
8	H-2330	4	9/16" ADAPTER	20	F-1015-05	2	1/4-20 X 1" CAPSCREW
9	-----	-	SEE PAGE 3-19	21	F-1546	4	5/16-18 x 3/4" CAPSCREW
10	H-2120	1	VENT CAP				
11	F-1125	2	5/16-18 STOVER NUT				
12	H-2447	1	OIL TANK				

E-6415 WIRE HARNESS & RELATED PARTS (JOYSTICK)

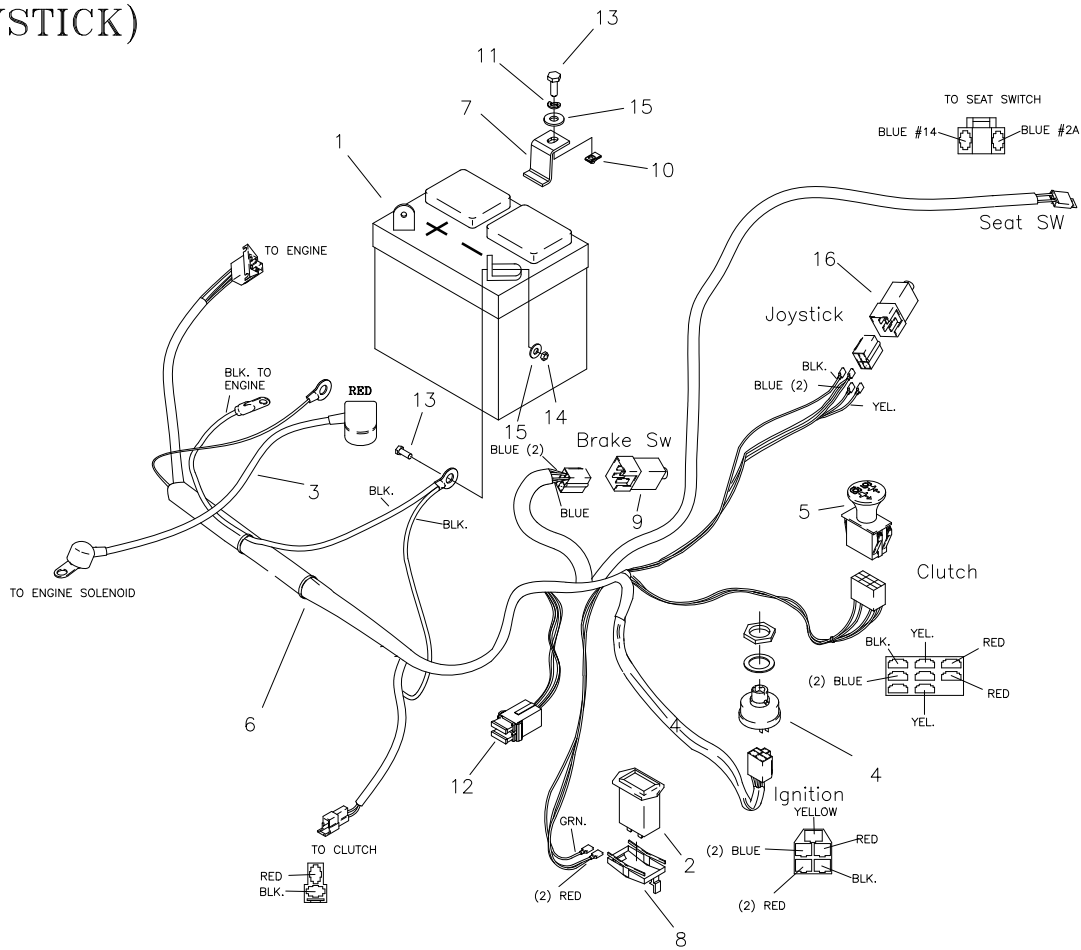

REF NO.	PART NO.	QTY.	DESCRIPTION
1	E-6271	1	BATTERY
2	E-5878	1	HOUR METER
3	E-6418	1	CABLE, BATTERY TO SOLENOID
4	E-5873	1	START SWITCH
5	E-6403	1	CLUTCH SWITCH
6	E-6415	1	WIRE HARNESS (JOYSTICK)
7	659-137P	1	BATTERY HOLD DOWN
8	E-6369	1	RETAINER CLIP
9	E-6297	2	BRAKE SWITCH
10	F-1858	1	1/4-20 U-NUT
11	F-1019-01	1	1/4" LOCK WASHER
12	E-6207	2	FUSE, #ATC-30
13	F-1538	3	1/4-20 X 3/4" GR. 5
14	F-1158	2	1/4-20 LOCK NUT
15	F-1009-01	5	1/4" FLAT WASHER
16	E-6474	1	JOYSTICK SWITCH
	E-6281	1	COVER (KEY SWITCH)
			-NOT SHOWN-

E-6416 WIRE HARNESS & RELATED PARTS (TWINSTICK)

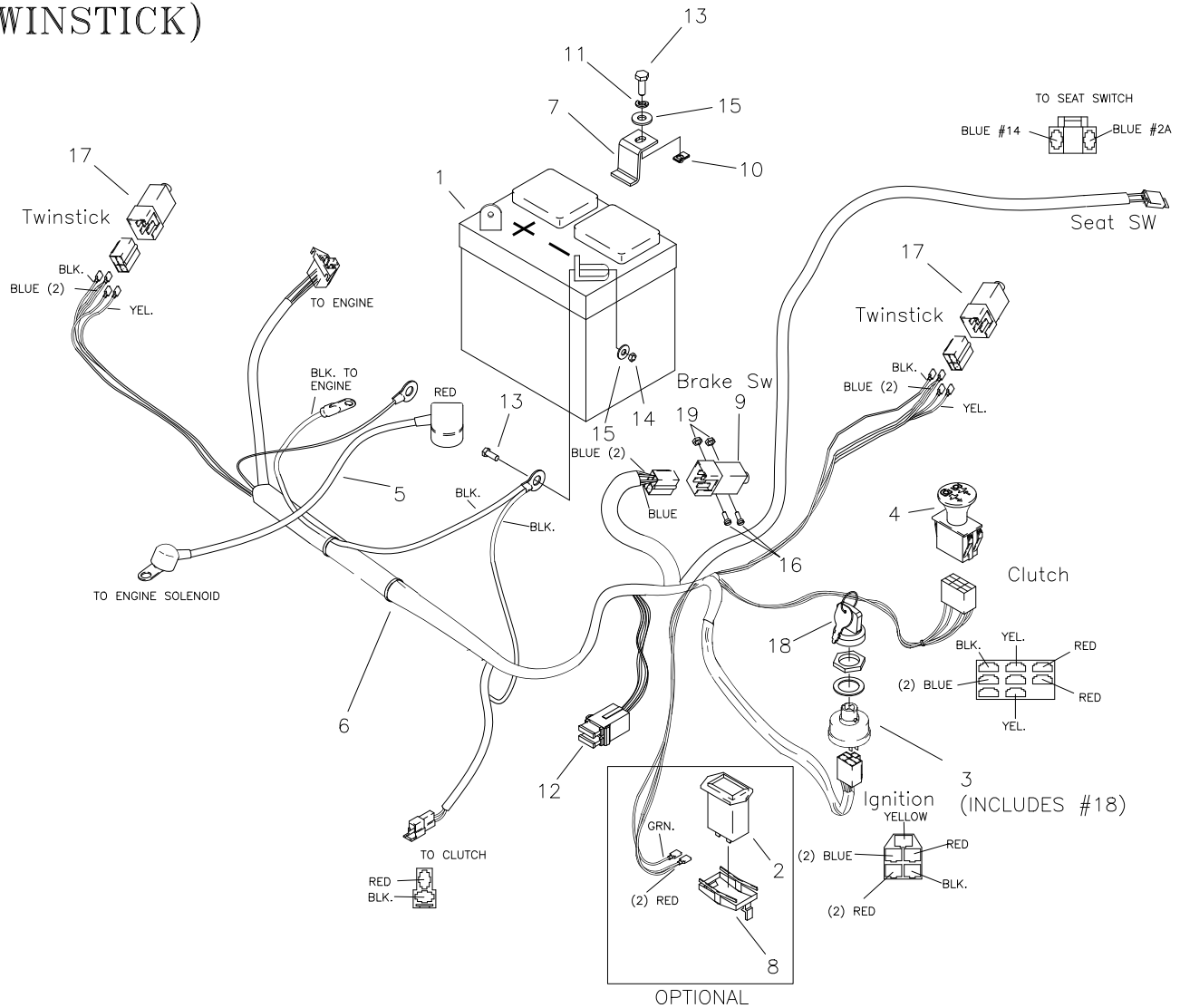

REF NO.	PART NO.	QTY.	DESCRIPTION
1	E-6271	1	BATTERY
2	E-5878	1	HOUR METER
3	E-5873	1	START SWITCH
4	E-6403	1	CLUTCH SWITCH
5	E-6418	1	CABLE, BATTERY TO SOLENOID
6	E-6416	1	WIRE HARNESS (TWINSTICK)
7	659-137P	1	BATTERY HOLD DOWN
8	E-6369	1	RETAINER CLIP
9	E-6297	1	BRAKE SWITCH
10	F-1858	1	1/4-20 U-NUT
11	F-1019-01	1	1/4" LOCK WASHER
12	E-6207	2	FUSE, #ATC-30
13	F-1538	3	1/4-20 X 3/4" GR. 5
14	F-1158	2	1/4-20 LOCK NUT
15	F-1009-01	5	1/4" FLAT WASHER
16	F-1022-26	2	SCREW, PHILLIPS, 10-32 X 5/8
17	E-6474	2	SWITCH, SNAP MOUNT
18	E-6445	1	KEY, SET
19	F-1448	2	LOCKNUT, 10-32 NYLOC
*	E-6281	1	COVER (KEY SWITCH) -NOT SHOWN-

E-6417 KAWASAKI ADAPTER HARNESS & RELATED PARTS

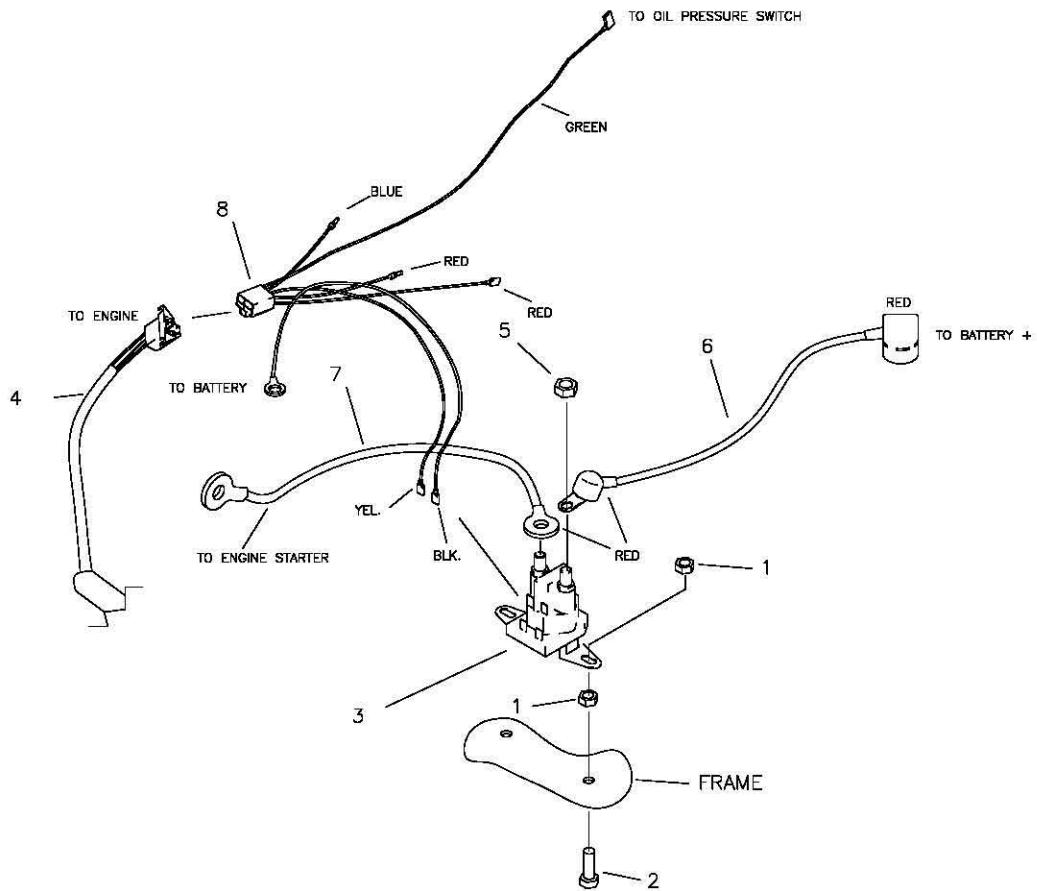

REF NO.	PART NO.	QTY.	DESCRIPTION
1	F-1158	4	1/4-20 LOCK NUT
2	F-1015-05	2	1/4-20 X 1" GR. 5
3	E-6054	1	SOLENOID
4	E-6415 or E-6416	1	KOHLER WIRE HARNESS (JOYSTICK) KOHLER WIRE HARNESS (TWINSTICK)
5	F-1011-01	2	1/4-20 NUT
6	E-6418	1	CABLE, BATTERY TO SOLENOID
7	E-6419	1	CABLE, SOLENOID TO ENGINE
8	E-6417	1	KAWASAKI HARNESS ADAPTER