

REPAIR PARTS MANUAL
FOR
COUNTRY
CLIPPER[®]

THE BOSS[™]

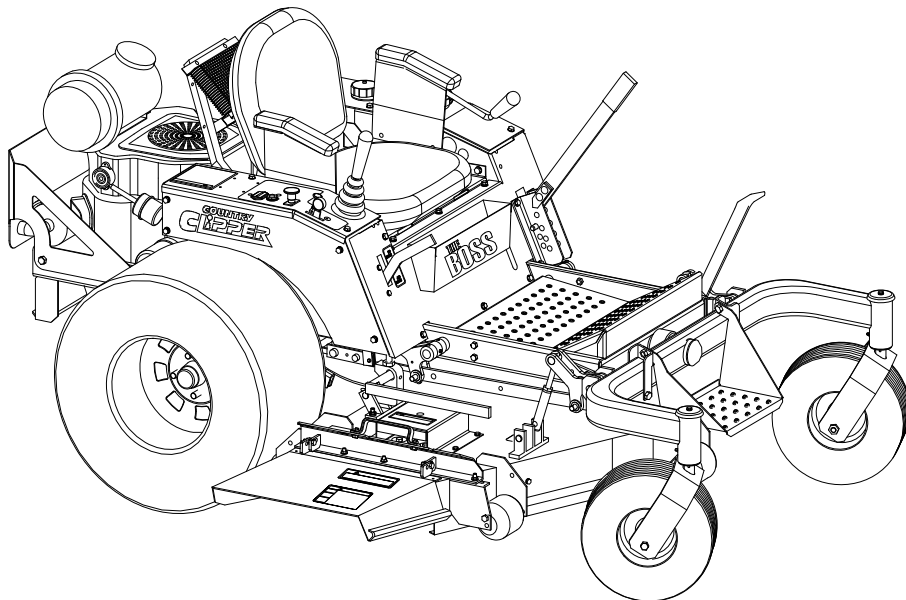

COUNTRY CLIPPER "THE BOSS" SR1210 (2010) ZERO TURN RADIUS MOWER TABLE OF CONTENTS

PAGE.... CONTENTS

SECTION 1 – MOWER DECKS AND RELATED PARTS

- 1 60" DECK ASSEMBLY
- 2 72" DECK ASSEMBLY
- 3 DECK SPINDLE ASSEMBLY
- 4 SINGLE IDLER & RELATED PARTS
- 5 LIFT HANDLE ASSEMBLY & RELATED PARTS
- 6 QRS. SYSTEM PARTS

SECTION 2 –TRACTOR FRAME AND RELATED PARTS

- 7 LIFT ASSEMBLY & RELATED PARTS
- 8 LIFT ASSEMBLY AND RELATED PARTS (72" BOSS)
- 9 STEP & RELATED PARTS
- 10 DOUBLE IDLER & RELATED PARTS
- 11 ANTI-ROTATING CASTER WHEEL ASSEMBLY
- 12 FRAME SIDES & RELATED PARTS
- 13 FENDER ASSEMBLY
- 14 SEAT, FOOT DECK & RELATED PARTS

SECTION 3 –TRACTOR DRIVE AND RELATED PARTS

- 15 FUEL INJECTION LINE ASSEMBLY
- 16 FUEL TANK ASSEMBLY
- 17 JACK ASSEMBLY
- 18 JOYSTICK STEERING CONTROL & RELATED PARTS
- 19 JOYSTICK STEERING CONTROL & RELATED PARTS (Con't)
- 20 RIGHT HAND STEERING CONTROL & RELATED PARTS
- 21 LEFT HAND STEERING CONTROL & RELATED PARTS
- 22 PARKING BRAKE ASSEMBLY & RELATED PARTS
- 23 GEAR MOTOR WHEEL ASSEMBLY
- 24 HIGH PRESSURE LINES AND FITTINGS FOR 60" & 72" BOSS
- 25 MOTOR ASSEMBLY & RELATED PARTS
- 26 ENGINE AND CLUTCH MOUNTING HARDWARE
- 27 MOTOR TO PUMP SINGLE IDLER
- 28 BATTERY BOX & RELATED PARTS
- 29 OIL RETURN LINES & COOLER ASSEMBLY
- 30 WIRE HARNESS & RELATED PARTS, JOYSTICK
- 31 WIRE HARNESS & RELATED PARTS, TWINSTICK

60" DECK ASSEMBLY (643L-002A)

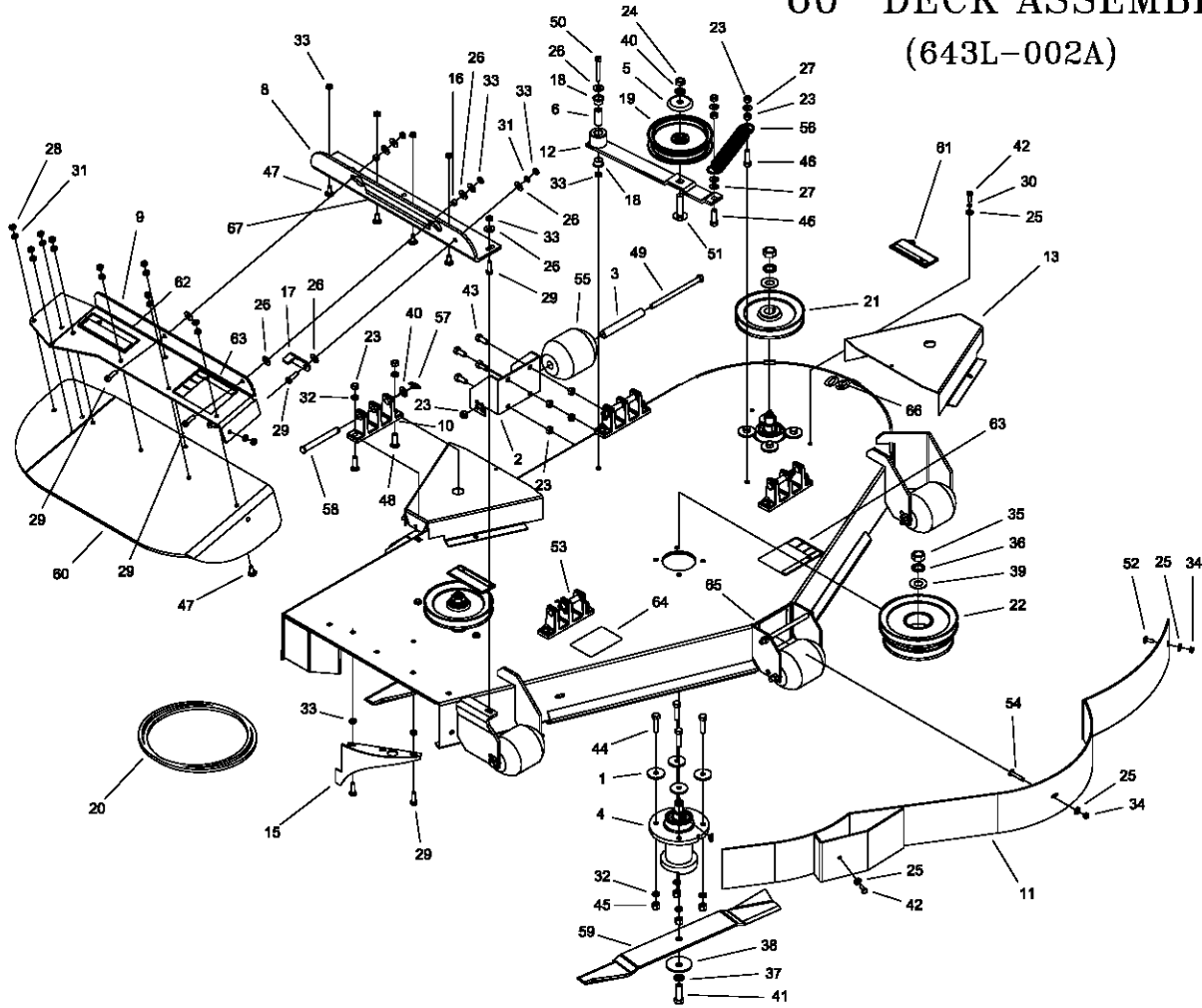

REF NO.	PART NO.	QTY.	DESCRIPTION	REF NO.	PART NO.	QTY.	DESCRIPTION
1	609-034P	12	SPINDLE SPACER WASHER	35	F-1461	3	3/4-16 JAM NUT
2	609-182P	3	BRACKET REAR CENTER	36	F-1463	3	3/4 LOCKWASHER
3	609-183P	6	BUSHING	37	F-1464	3	1/2" LOCKWASHER
4	609F-019A	3	DECK SPINDLE ASSEMBLY	38	F-1507	3	CUPPED WASHER, 1/2"
5	620-201P	1	WASHER, BEARING CAP	39	F-1510	3	3/4 FLAT WASHER
6	621-103P	1	MOUNTING PIN	40	F-1521	5	1/2" WASHER
7	629-237P	6	WASHER, .406 ID X 1 OD X 10 GA	41	F-1526	3	1/2-13 x 1-1/2" CAPSCREW
8	637-072P	1	OUTLET STIFFENER	42	F-1538	5	1/4-20 x 3/4" CAPSCREW
9	637-073P	1	CHUTE FRAME	43	F-1558	12	3/8-16 x 7/8" CAPSCREW
10	643-016W	4	HANGER WELDMENT	44	F-1572	12	3/8-24 x 1.5" CAPSCREW
11	643-047W	1	DUST BAFFLE	45	F-1573	12	3/8-24 LOCKNUT
12	643-078W	1	SINGLE IDLER ARM WELDMENT	46	F-1574	2	3/8-16 x 1-1/2" CAPSCREW
13	643-080P	2	60" PULLEY COVER	47	F-1671	13	5/16-18 x 3/4" CARRIAGE BOLT
14	643L-003W	1	60" BOSS DECK WELDMENT	48	F-1672	8	3/8-16 x 1-1/4" CARRIAGE BOLT
15	686-006W	1	SPLITTER BAFFLE	49	F-1741	7	3/8-16 x 6" CAPSCREW
16	686-036P	2	SPACER	50	F-1800	1	5/16-18 SHSC 2-1/4"
17	686-079P	1	LATCH	51	F-1822	1	1/2-13 X 2-1/4" CARRIAGE BOLT
18	D-3730	2	FLANGED BUSHING 5/8" BORE	52	F-1823	1	CARRIAGE BOLT, 1/4 X 3/4"
19	D-3774	1	IDLER PULLEY 5" X 2"	53	F-1889	2	1/2 x 2-5/8" CLEVIS PIN
20	D-3796	1	BELT, B-124	54	F-1935	1	CARRIAGE BOLT, 1/4 X 1-1/2"
21	D-3800	2	6 1/4" 1 GROOVE PULLEY	55	H-1948	6	Roller, 3-3/4 DIA. x 4-13/16L
22	D-3802	1	PULLEY DOUBLE B SMALL	56	H-2092	1	1-1/4" x 5" EXTENSION SPRING
23	F-1005-03	31	3/8-16 STOVER NUT	57	H-2239	4	1/2" RUE RING
24	F-1005-05	1	1/2-13 STOVER NUT	58	H-2240	2	1/2" x 4-1/2" CLEVIS PIN
25	F-1009-01	7	1/4" FLAT WASHER	59	H-2500	3	60" FUSION BLADE
26	F-1009-02	10	5/16" FLAT WASHER	60	H-2613	1	RUBBER CHUTE
27	F-1009-03	4	3/8" FLAT WASHER	61	P-10935	2	Decal, WARNING
28	F-1011-02	9	5/16-18 NUT	62	P-10937	1	DECAL "WARNING TO AVOID SERIOUS"
29	F-1015-15	6	5/16-18 x 1" CAPSCREW	63	P-10941	2	DECAL "DANGER ROTATING BLADES"
30	F-1019-01	4	1/4" LOCKWASHER	64	P-10947	1	DECAL "GREASE DECK SPINDLES"
31	F-1019-02	10	5/16" LOCKWASHER	65	P-11413	1	DECAL, HOIST POINT
32	F-1019-03	20	3/8" LOCKWASHER	66	P-11952	1	DECAL, DECK SIZE, 52
33	F-1125	11	5/16-18 STOVER NUT	67	P-12496	1	DECAL, MISSING CHUTE
34	F-1158	2	1/4-20 STOVER NUT				

72" DECK ASSEMBLY (643M-002A)

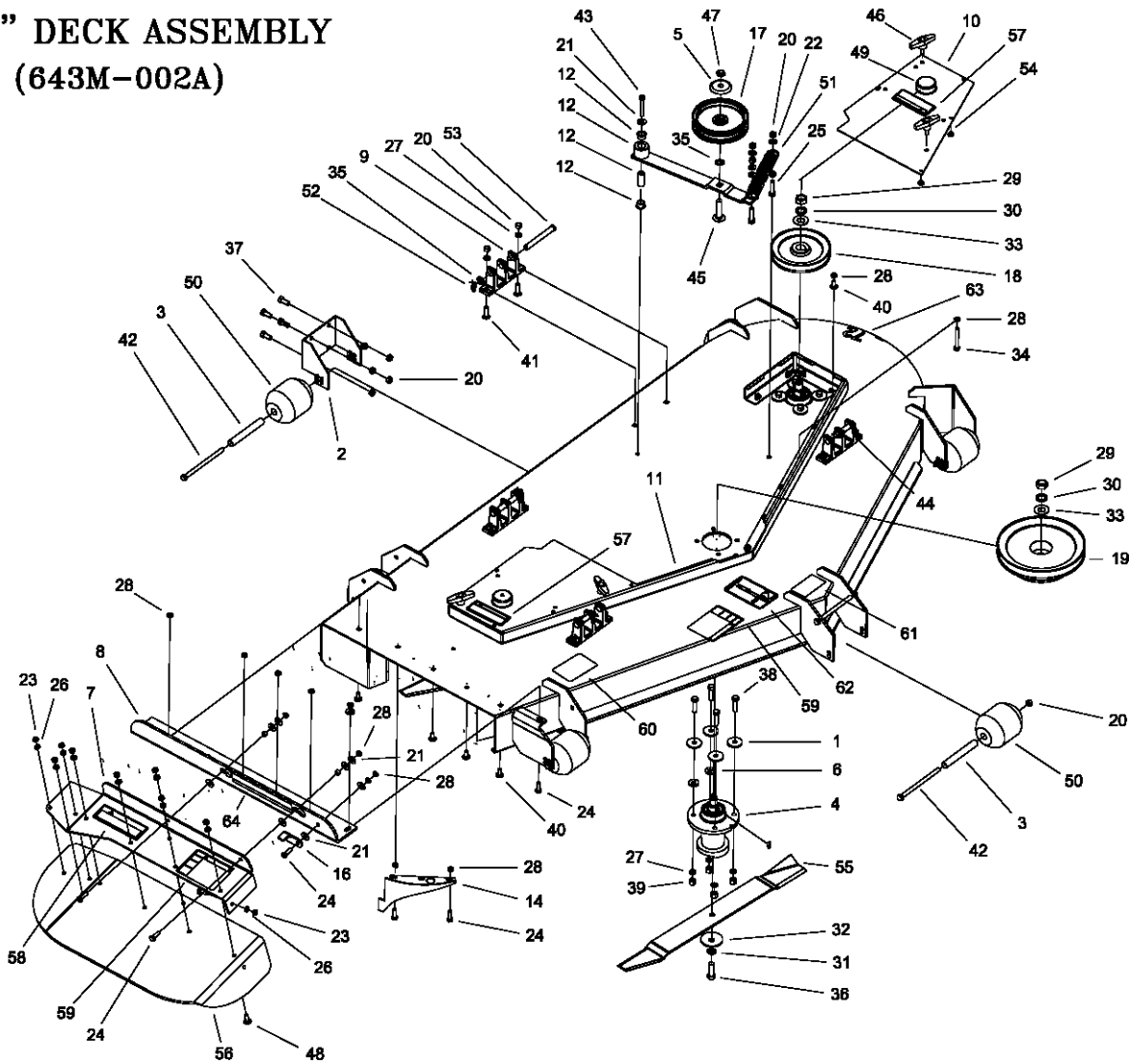

REF NO.	PART NO.	QTY.	DESCRIPTION	REF NO.	PART NO.	QTY.	DESCRIPTION
1	609-034P	12	SPINDLE SPACER WASHER	33	F-1510	3	3/4" FLAT WASHER
2	609-182P	1	BRACKET REAR CENTER	34	F-1518	4	5/16-18 x 2-1/2" CAPSCREW
3	609-183P	6	BUSHING	35	F-1521	5	1/2" WASHER
4	609F-019A	3	DECK SPINDLE ASSEMBLY	36	F-1526	3	1/2-13 x 1-1/2" CAPSCREW
5	620-201P	1	WASHER, BEARING CAP	37	F-1558	4	3/8-16 x 7/8" CAPSCREW
6	629-237P	6	WASHER, .406 ID X 1 OD X 10 GA	38	F-1572	12	3/8-24 x 1.5" CAPSCREW
7	637-073P	1	CHUTE FRAME	39	F-1573	12	3/8-24 LOCKNUT
8	637-075P	1	OUTLET STIFFENER, 72"	40	F-1671	22	5/16-18 x 3/4" CARRIAGE BOLT
9	643-016W	4	HANGER WELDMENT	41	F-1672	8	3/8-16 x 1-1/4" CARRIAGE BOLT
10	643-054P	2	BELT COVER 72" (LEFT)	42	F-1741	7	3/8-16 x 6" CAPSCREW
11	643-068P	1	STIFFENER TOP 72"	43	F-1800	1	5/16-18 SHSC 2-1/4"
12	643-079A	1	SINGLE IDLER ARM LONG ASSEMBLY	44	F-1816	2	1/2" x 2-1/2" CLEVIS PIN
13	643M-003W	1	72" DECK WELDMENT	45	F-1822	1	1/2-13 X 2-1/4" CARRIAGE BOLT
14	686-006W	1	SPLITTER BAFFLE	46	F-1921	4	T HANDLE KNOB
15	686-036P	2	SPACER	47	F-1966	1	1/2-13 THIN NYLOC NUT
16	686-079P	1	LATCH	48	F-2066	9	5/16-18 x 1" CARRIAGE BOLT,
17	D-3774	1	IDLER PULLEY 5" X 2"	49	H-1798	2	2 GREASE CAP
18	D-3800	2	6 1/4" 1 GROOVE PULLEY	50	H-1948	6	ROLLER, 3-3/4 DIA. x 4-13/16L
19	D-3801	1	PULLEY DOUBLE B LARGE	51	H-2092	1	1-1/4" x 5" EXTENTION SPRING
20	F-1005-03	23	3/8-16 STOVER NUT	52	H-2239	4	1/2" RUE RING
21	F-1009-02	10	5/16" FLAT WASHER	53	H-2240	2	1/2" x 4-1/2" CLEVIS PIN
22	F-1009-03	4	3/8" FLAT WASHER	54	H-2461	8	RUBBER BUMPER
23	F-1011-02	9	5/16-18 NUT	55	H-2501	3	HIGH LIFT BLADE 25"
24	F-1015-15	6	5/16-18 x 1" CAPSCREW	56	H-2613	1	RUBBER CHUTE
25	F-1015-27	2	3/8-16 x 1-1/2" CAPSCREW	57	P-10935	2	DECAL, WARNING
26	F-1019-02	10	5/16" LOCKWASHER	58	P-10937	1	DECAL "WARNING TO AVOID SERIOUS"
27	F-1019-03	20	3/8" LOCKWASHER	59	P-10941	2	DECAL "DANGER ROTATING BLADES"
28	F-1125	33	5/16-18 STOVER NUT	60	P-10947	1	DECAL "GREASE DECK SPINDLES"
29	F-1461	3	3/4-16 JAM NUT	61	P-11413	1	DECAL, HOIST POINT
30	F-1463	3	3/4 LOCKWASHER	62	P-11935	1	DECAL, WARNING
31	F-1464	3	1/2" LOCKWASHER	63	P-11953	1	DECAL, DECK SIZE, 72
32	F-1507	3	CUPPED WASHER, 1/2"	64	P-12496	1	DECAL, MISSING CHUTE

DECK SPINDLE ASSEMBLY

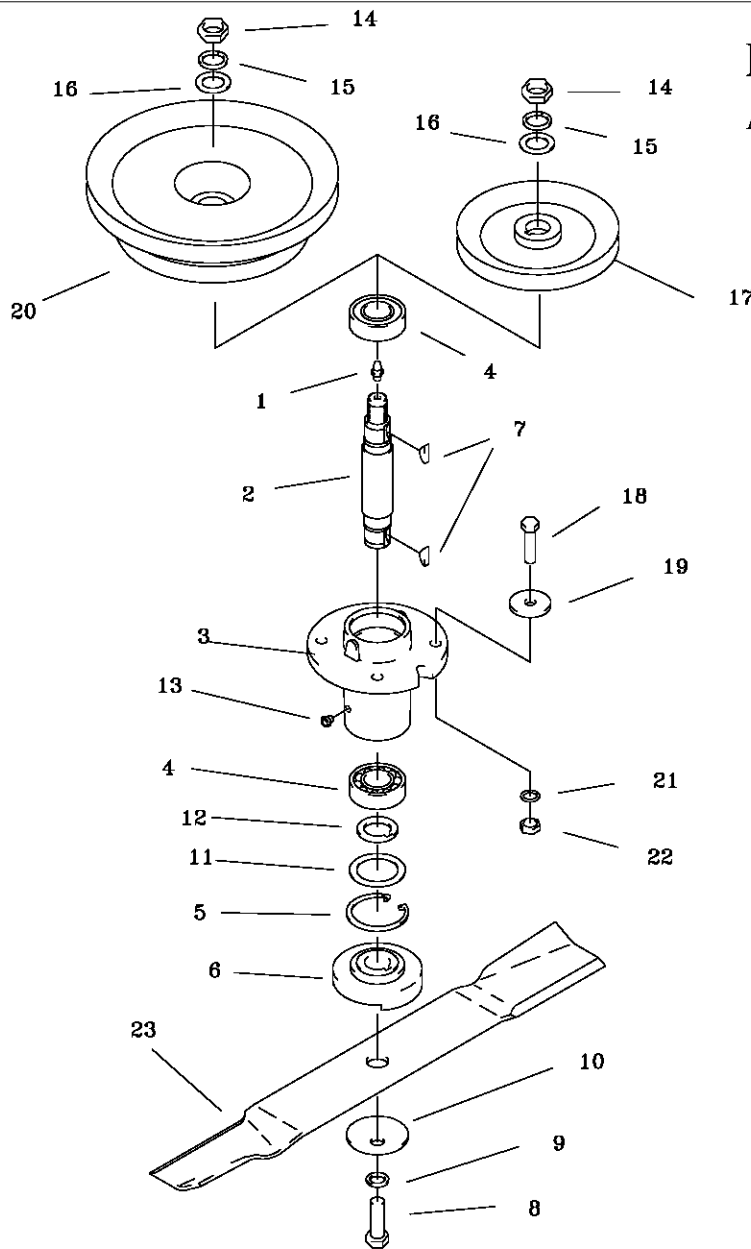

REF NO.	PART NO.	QTY.	DESCRIPTION	REF NO.	PART NO.	QTY.	DESCRIPTION
-	609F-019A	-	SPINDLE ASSEMBLY	20	D-3802	-	PULLEY, 2 GROOVE 60"
1	H-1056	1	GREASE FITTING	-	D-3801	-	PULLEY, 2 GROOVE 72"
2	609-162P	1	SPINDLE SHAFT	21	F-1019-03	4	3/8" LOCK WASHER
3	609-223P	1	SPINDLE HOUSING	22	F-1573	4	3/8-24 LOCKNUT, M-F
4	D-3058	2	BEARING, #6205-2RS	23	H-2500	-	FUSION, HIGH L, 21" CUT 60"
5	H-1893	1	SNAP RING INT. 52MM	-	H-2501	-	FUSION, HIGH L, 25" CUT 72"
6	609-152P	1	BLADE SPACER	-	H-1667	-	BLADE, LOW L, 21" CUT 60"
7	D-1004-02	2	KEY, WOODRUF, 1/4 X 3/4	-	H-2397	-	BLADE, LOW L, 25" CUT 72"
8	F-1526	1	1/2-13 X 1-1/2" HHCS GR. 5	-	H-1708	-	BLADE, HIGH L, 21" CUT 60"
9	F-1464	1	1/2" LOCK WASHER	-	H-2459	-	BLADE, HIGH L, 25" CUT 72"
10	F-1507	1	WASHER, 1/2" CUPPED	-	H-2203	-	BLADE, GATOR 21" CUT 60"
11	609-151P	1	WASHER, SEAL				
12	609-073P	1	ARBOR SPACER				
13	H-2066	1	GREASE VENT 5 LBS.				
14	F-1461	1	3/4-16 NUT, HEX JAM				
15	F-1463	1	3/4" LOCK WASHER				
16	F-1510	1	3/4" WASHER, FLAT STD.				
17	D-3800	-	PULLEY, 1 GROOVE 6 3/16"				
18	F-1572	4	3/8-24 X 1-1/2" HHCS GR. 5				
19	609-034P	4	SPINDLE SPACER REINFORCEMENT				

SINGLE IDLER ASSEMBLY & RELATED PARTS

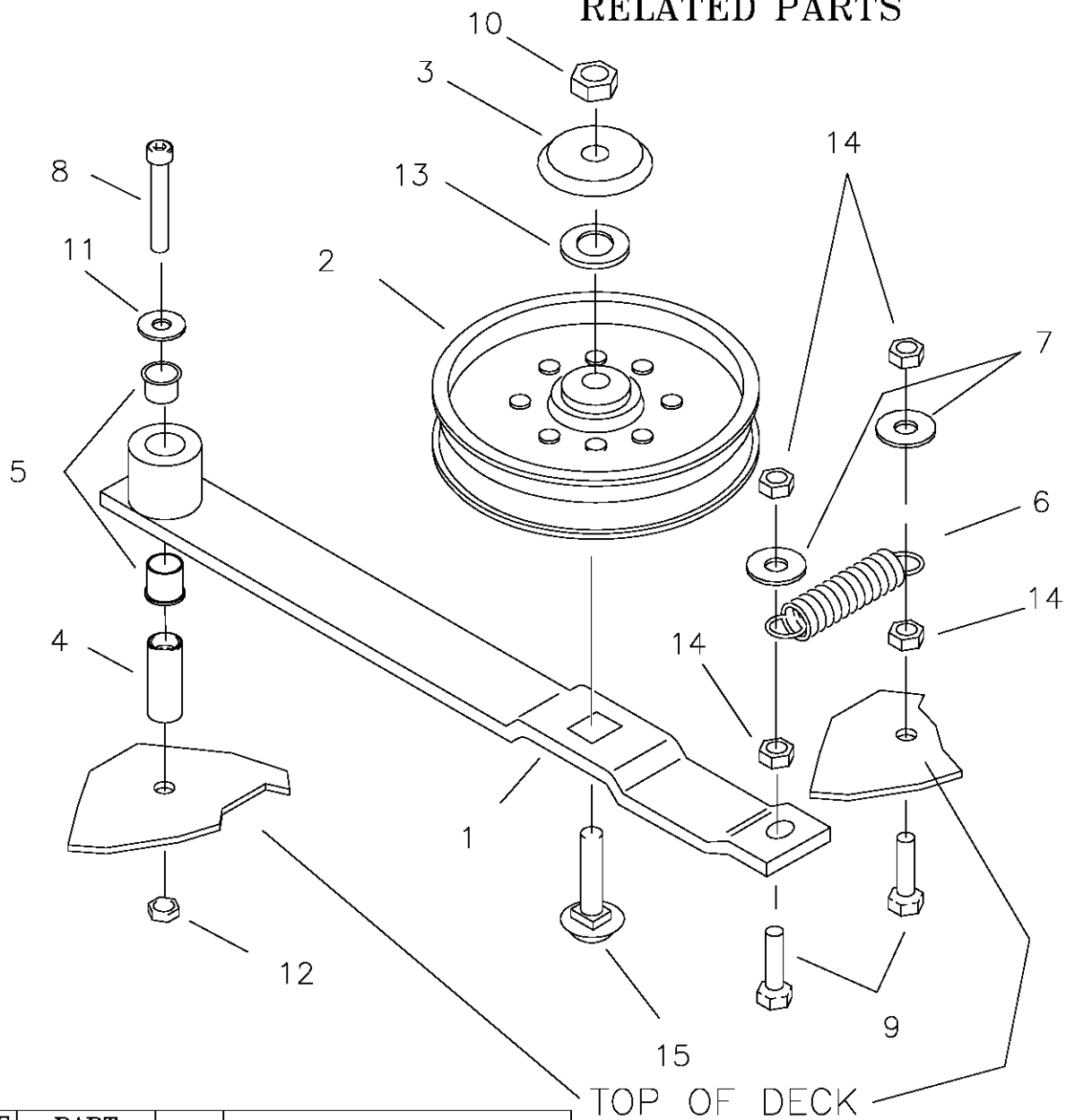

REF NO.	PART NO.	QTY.	DESCRIPTION
1	661-090A	1	SINGLE IDLER
2	D-3774	1	5" IDLER PULLEY
3	620-201P	1	BEARING CAP
4	621-103P	1	PIN
5	D-3730	2	BUSHING, TEFLON COATED
6	H-2619	1	SPRING, 1-1/2" X 5"
7	609-034P	2	REINFORCEMENT WASHER
8	F-1820	1	5/16-18 SHCS X 2-1/4"
9	F-1574	2	3/8-24 X 1-1/4" GR. 5
10	F-1005-05	1	1/2-13 STOVER NUT
11	F-1009-02	1	5/16 FLAT WASHER
12	F-1005-03	1	5/16 STOVER NUT
13	F-1521	1	1/2" FLAT WASHER
14	F-1573	3	3/8" LOCK NUT
15	F-1927	1	CARRIAGE BOLT, 1/2 X 2 3/4"

LIFT HANDLE ASSEMBLY & RELATED PARTS

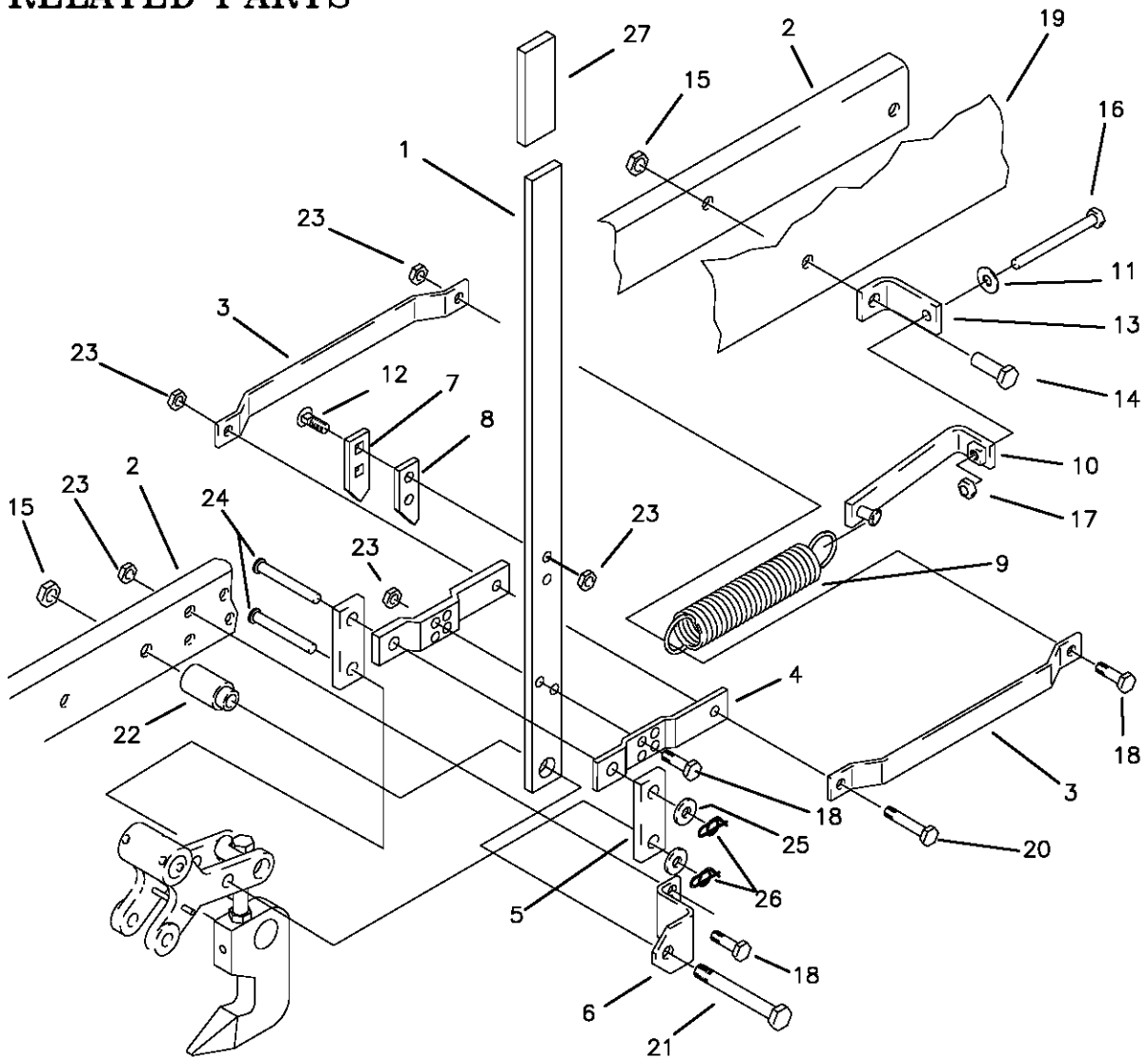

REF NO.	PART NO.	QTY.	DESCRIPTION	REF NO.	PART NO.	QTY.	DESCRIPTION
1	642-062P	1	LIFT HANDLE	14	F-1526	1	3/8-16 X 1-1/2" GR. 5
2	647-143W	1	FRAME WELDMENT, LH.	15	F-1005-05	2	NUT, 1/2-13 LOCKNUT
3	642-055P	2	SPRING EXTENSION	16	F-1646	1	3/8-16 X 5" FULL THREAD
4	642-060P	2	SPRING ANCHOR PLATE	17	F-1011-03	1	HEX NUT, 3/8-16 UNC-2B
5	642-061P	2	HANDLE LINK	18	F-1307	5	3/8-16 X 1-1/4" GR. 5
6	642-041P	1	HANDLE PIVOT BRACKET	19	647-137P	1	SIDE PANEL, LH
7	642-127P	1	TOP PEG LATCH PLATE	20	F-1015-30	1	3/8-16 X 2 1/2" GR. 5
8	642-126P	1	TOP PEG SPACER PLATE	21	F-1828	1	1/2-13 X 3-1/2" GR. 5
9	H-1610	1	SPRING, 1-1/2" OD. X 8"	22	642-095P	1	HANDLE PIVOT PIN
	H-1868	1	SPRING, HEAVY 8" (72" DECK)	23	F-1005-03	7	NUT, 3/8-16 LOCKNUT (STOVER)
10	620-227W	1	SPRING TIGHTENER WLDT.	24	F-1889	2	CLEVIS PIN, 1/2 X 2-5/8"
11	F-1009-03	1	FLAT WASHER, 3/8"	25	F-1521	2	1/2" FLAT WASHER
12	F-1672	2	3/8-16 X 1-1/4" CARRIAGE BOLT	26	H-2239	2	RUE RING, 1/2"
13	642-053P	1	SPRING ANCHOR WELDMENT	27	H-2324	1	VINYL GRIP, 3/8 X 1-1/2"

**LIFT ASSEMBLY
& RELATED PARTS
60" DECKS**

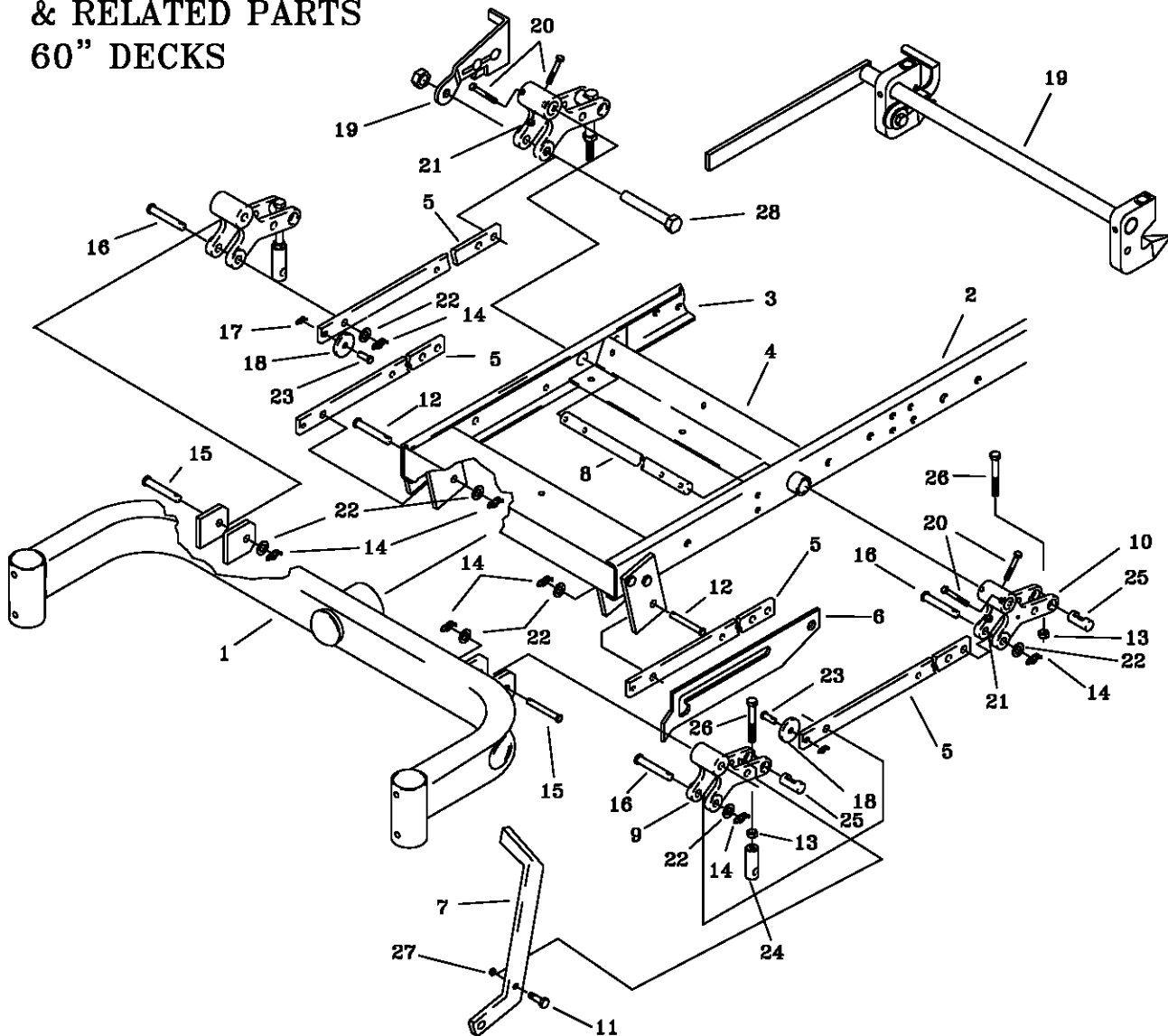

REF NO.	PART NO.	QTY.	DESCRIPTION	REF NO.	PART NO.	QTY.	DESCRIPTION
1	642-185W	1	FRONT AXLE WELDMENT	19	-----	1	QRS SYSTEM, SEE PAGE 6
2	647-142W	1	FRAME WELDMENT, RH	20	F-2039	4	5/16-24 x 2" HHCS
3	647-143W	1	FRAME WELDMENT, LH	21	F-2041	4	5/16-24 LOCK NUT
4	642-019W	1	FRONT PIVOT CHANNEL	22	F-1521	7	WASHER, 1/2 NARROW
5	642-059P	4	LINK BAR	23	F-1691	2	CLEVIS PIN, 3/8 X 1"
6	642-100P	1	DECK LATCH FLIP UP	24	642-175P	2	ADJUSTABLE HANGER END
7	629-249W	1	DECK LIFT PEDAL	25	642-177P	4	HANGER PIN
8	620-051P	1	LIFT BAR	26	F-1936	4	1/2-13 X 3-1/2, 2" THREAD
9	642-081P	2	LIFT SLEEVE, FRONT	27	F-1125	1	5/16 LOCKNUT
10	642-082P	2	LIFT SLEEVE, REAR	28	F-1828	1	1/2-13 X 3-1/2" BOLT
11	F-1879	1	5/16-18 X 1 1/4", GR.5				
12	F-1896	2	CLEVIS PIN, 1/2 X 1-3/4"				
13	F-1489	4	NUT, 1/2" JAM				
14	H-2239	7	RUE RING, 1/2"				
15	F-1890	2	CLEVIS PIN, 1/2 X 3-1/2"				
16	F-1898	3	CLEVIS PIN, 1/2 X 2-3/4"				
17	F-1492	2	RUE RING, 5/16-3/8 PIN				
18	642-105P	2	ROLLER				

LIFT ASSEMBLY
& RELATED PARTS
WIDE FRONT END

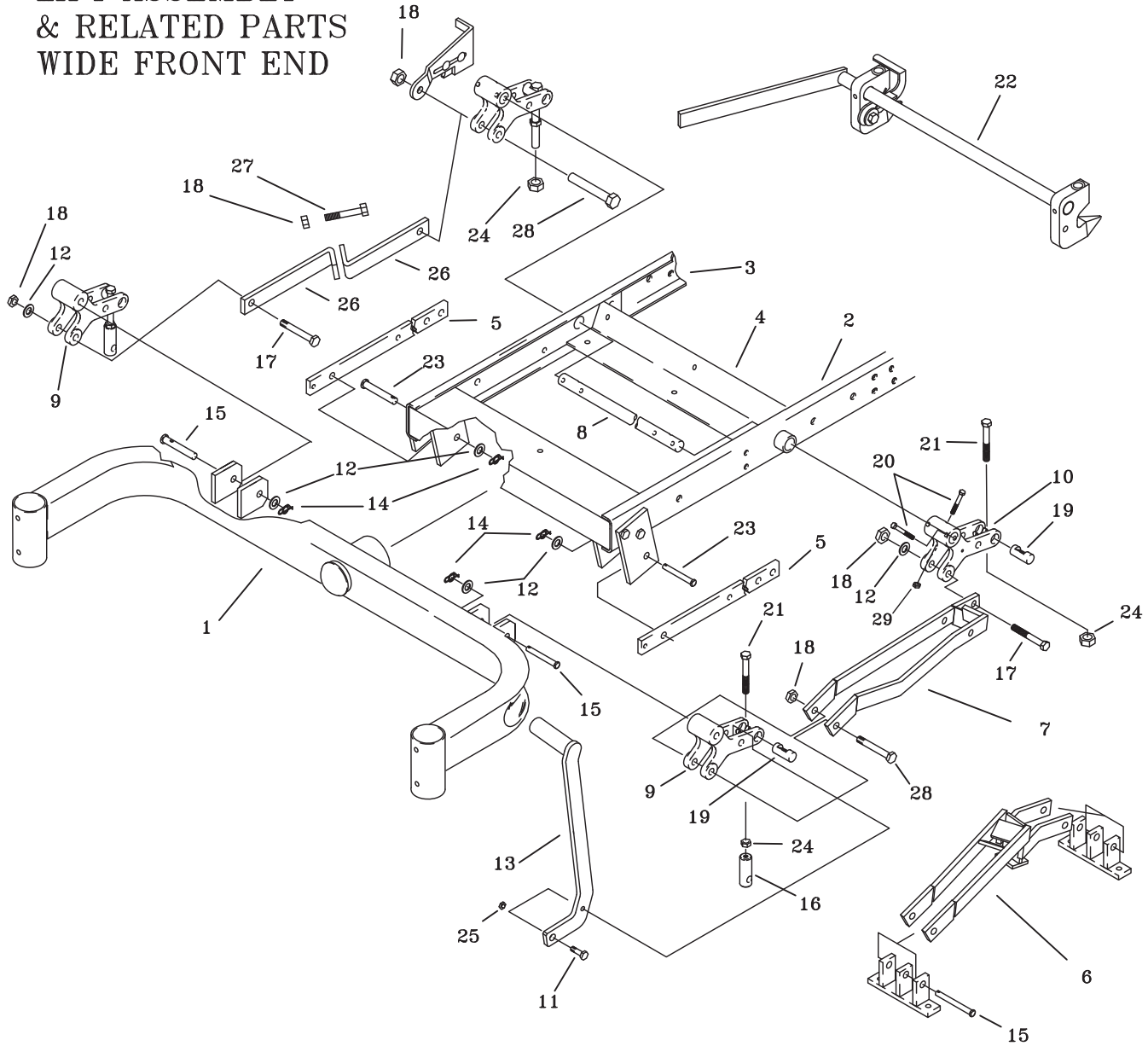

REF NO.	PART NO.	QTY.	DESCRIPTION	REF NO.	PART NO.	QTY.	DESCRIPTION
1	642-186W	1	WIDE FRONT AXLE WELDMENT	18	F-1005-05	5	NUT, 1/2" STOVER
2	647-142W	1	FRAME WELDMENT, RH	19	642-177P	2	HANGER PIN
3	647-143W	1	FRAME WELDMENT, LH	20	F-2039	4	5/16-24 x 2" HHCS BOLT
4	642-019W	1	FRONT PIVOT CHANNEL	21	F-1936	4	1/2-13 X 3-1/2, 2" THREAD
5	642-059P	2	LINK BAR	22	----	1	QRS SYSTEM, SEE PAGE 6
6	629-545W	1	LOWER JACK MNT.	23	F-1896	2	CLEVIS PIN, 1/2 X 1-3/4"
7	629-540W	1	UPPER JACK MNT.	24	F-1489	4	NUT, 1/2" JAM
8	620-051P	1	LIFT BAR	25	F-1125	1	5/16" LOCKNUT
9	642-081P	2	LIFT SLEEVE, FRONT	26	647-144P	2	OFFSET LINK BAR ADJUSTABLE
10	642-082P	2	LIFT SLEEVE, REAR	27	F-1386	1	1/2-13 X 1-1/4" BOLT
11	F-1879	1	5/16-18 X 1-1/4" BOLT	28	F-1828	2	1/2-13 X 3-1/2" BOLT
12	F-1521	7	WASHER, 1/2 NARROW	29	F-2041	4	5/16-24 LOCKNUT
13	629-249W	1	OFFSET DECK LIFT PEDAL				
14	H-2239	3	RUE RING, 1/2"				
15	F-1890	3	CLEVIS PIN, 1/2 X 3-1/2"				
16	642-175P	2	ADJUSTABLE HANGER END				
17	F-1439	3	1/2-13 X 3", GR.5				

STEP & RELATED PARTS

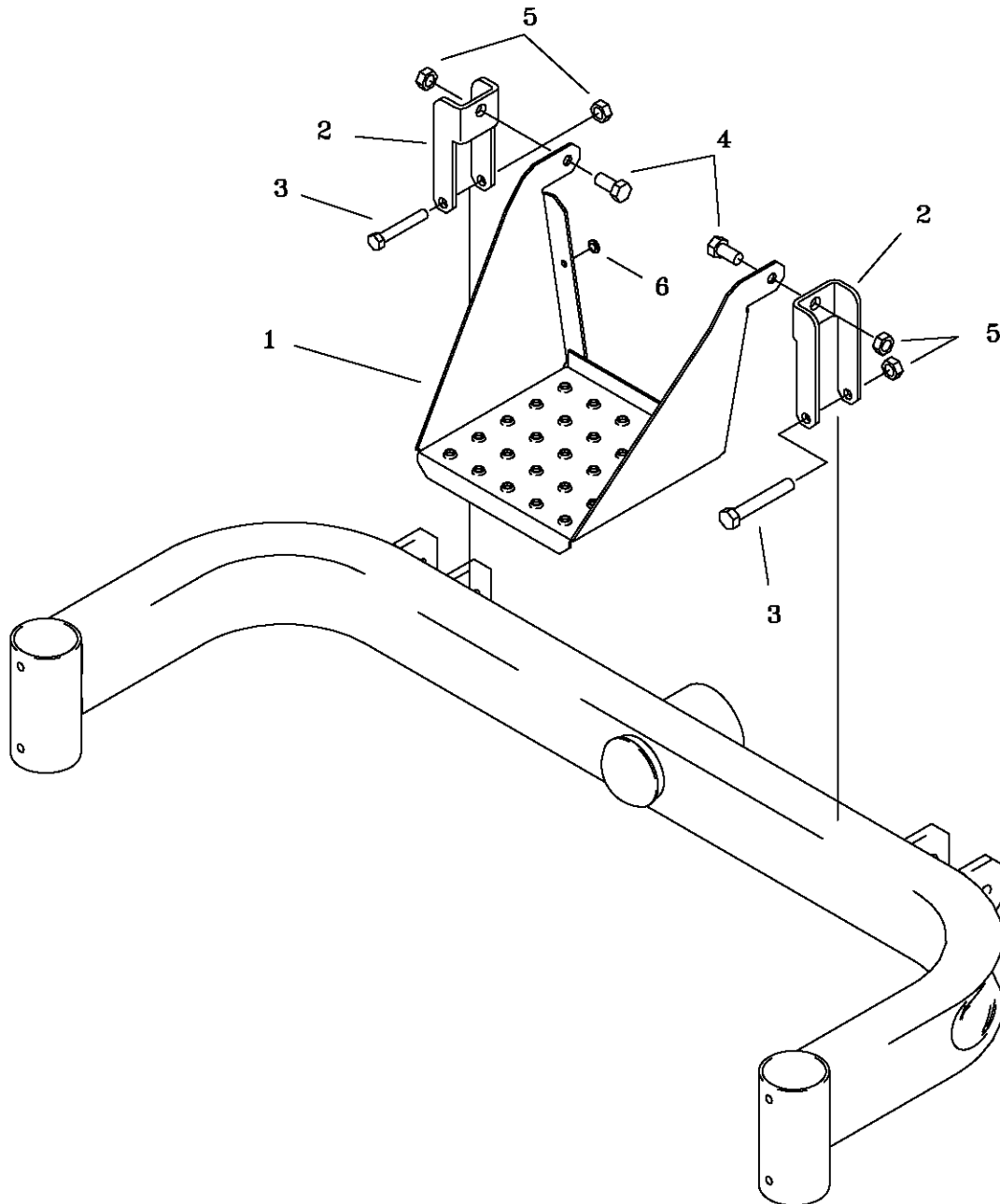

REF NO.	PART NO.	QTY.	DESCRIPTION
1	647-133P	1	STEP
2	647-134P	2	YOKE
3	F-1537	2	3/8-16 X 3" BOLT
4	F-1015-23	2	3/8-16 X 3/4" BOLT
5	F-1005-03	4	3/8-16 STOVER NUT
6	H-2461	2	BUMPER, RUBBER

DOUBLE IDLER & RELATED PARTS

VIEWED FROM RIGHT REAR

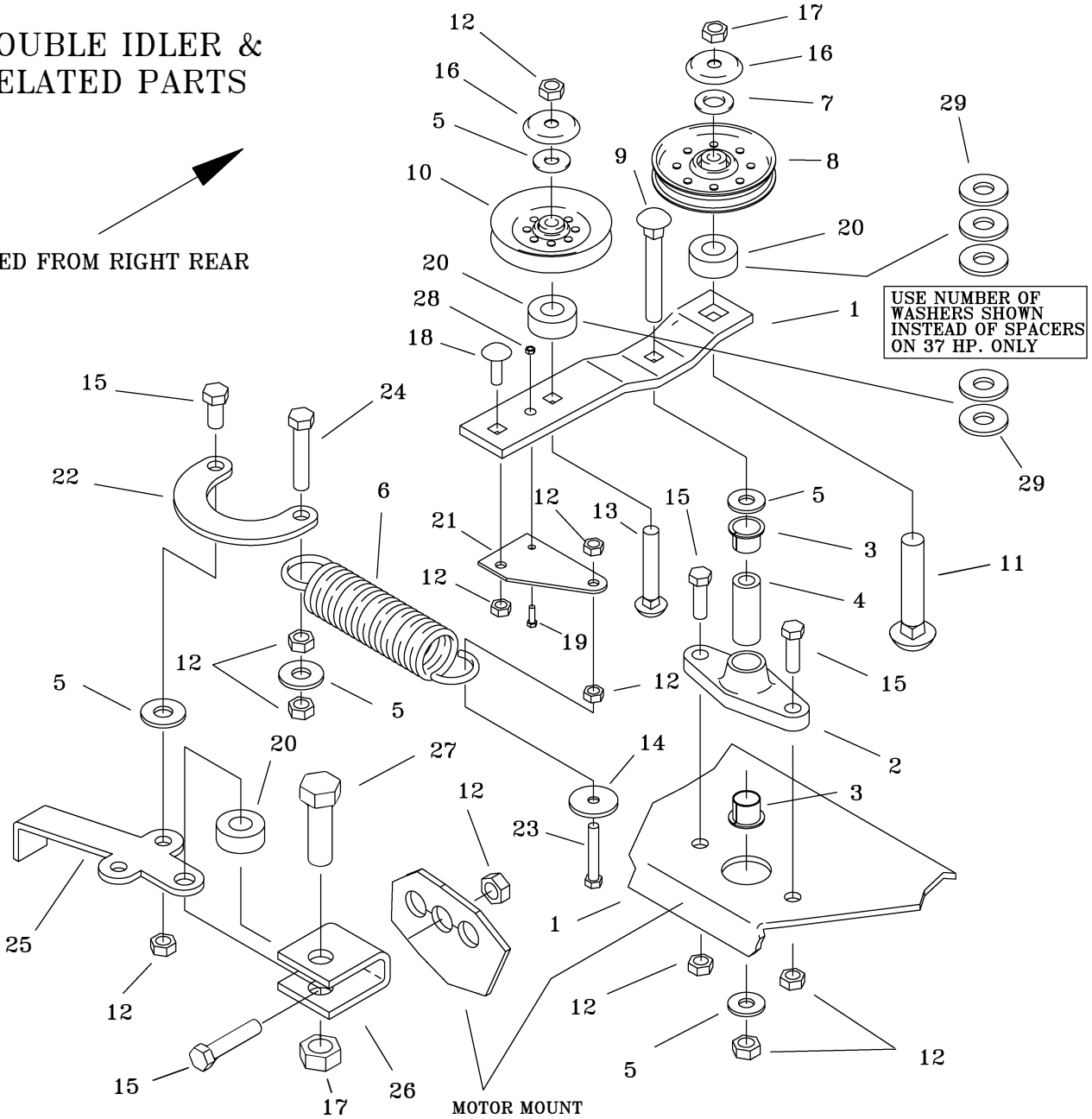

USE NUMBER OF WASHERS SHOWN INSTEAD OF SPACERS ON 37 HP. ONLY

REF NO.	PART NO.	QTY.	DESCRIPTION	REF NO.	PART NO.	QTY.	DESCRIPTION
1	660-036P	1	IDLER ARM	17	F-1005-05	2	1/2" STOVER NUT
2	660-039P	1	DOUBLE IDLER MOUNT	18	F-1008-23	1	3/8-16 X 3/4 CARRIAGE BOLT
3	D-3730	2	BUSHING	19	F-1538	1	1/4 X 3/4 BOLT
4	659-085P	1	MOUNTING PIN	20	660-038P	3	SPACER (NOT ON 37)
5	F-1009-03	5	3/8" FLAT WASHER	21	647-193P	1	IDLER EXTENSION
6	H-2619	1	SPRING	22	647-194P	1	BELT TIGHTENER LOOP
7	F-1521	1	1/2" FLAT WASHER, (NARROW)	23	F-1073	1	3/8-16 X 2" BOLT
8	D-3617	1	IDLER PULLEY	24	F-1307	1	3/8-16 X 1-1/4' BOLT
9	F-1865	1	3/8-16 X 2-1/2" CARRIAGE BOLT	25	660-030P	1	HANDLE
10	D-3758	1	"V" IDLER PULLEY	26	661-015P	1	SHACKLE
11	F-1822	1	1/2-13 X 2-1/4" CARRIAGE BOLT	27	F-1526	1	1/2-13 X 1-1/2" BOLT
12	F-1005-03	10	3/8-16 STOVER NUT	28	F-1158	1	1/4-20 LOCK NUT
13	F-1976	1	3/8-16 X 1-1/2" CARRIAGE BOLT	29	F-1521	5	1/2" FLAT WASHER (37 HP ONLY)
14	609-034P	1	SPINDLE SPACER WASHER				
15	F-1394	4	3/8-16 X 1" BOLT				
16	620-201P	2	BEARING CAP				

FRAME SIDES & RELATED PARTS

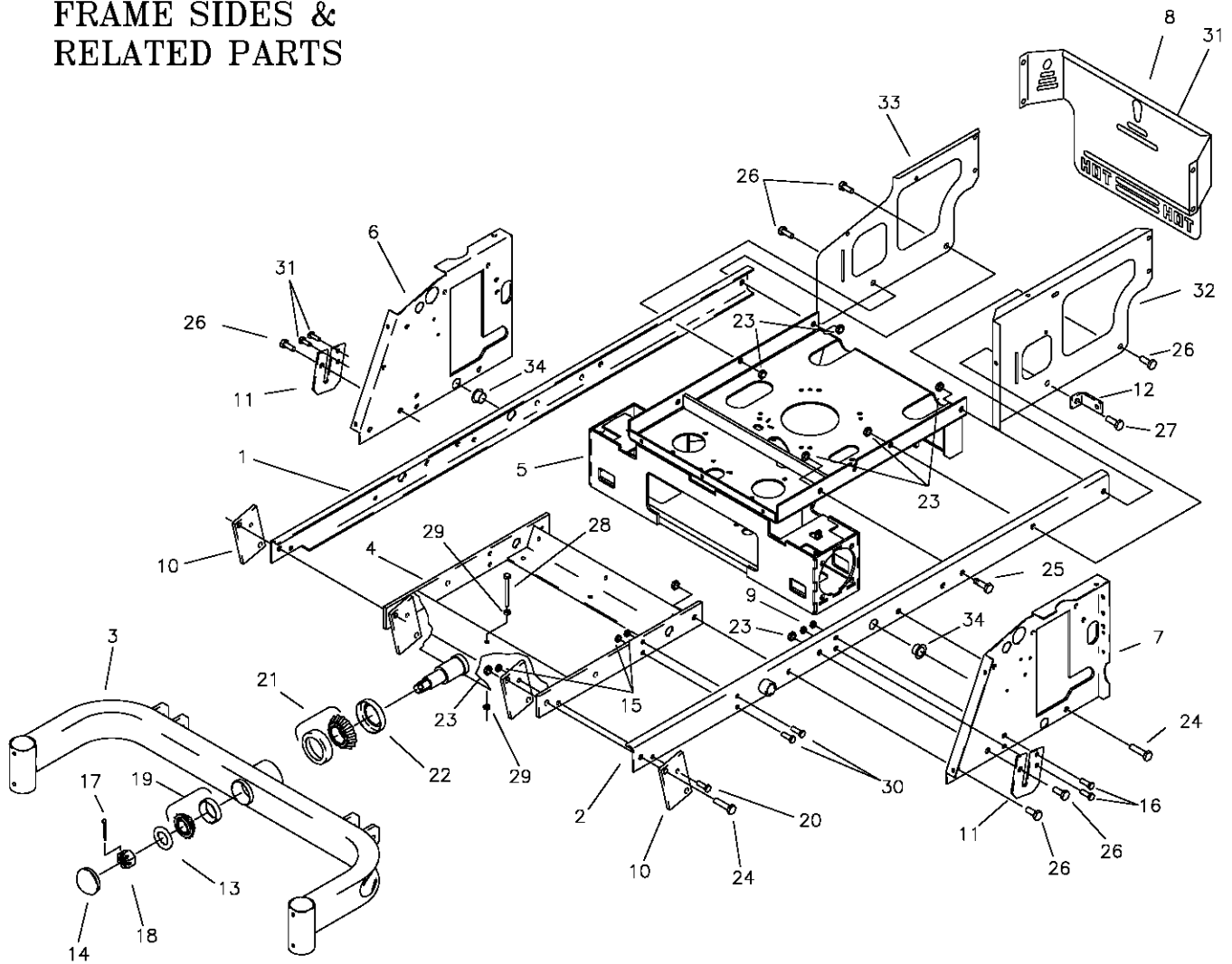

REF NO.	PART NO.	QTY.	DESCRIPTION	REF NO.	PART NO.	QTY.	DESCRIPTION
1	647-143W	1	FRAME SIDE LH.	18	F-1724	1	1"-14 CASTLE NUT
2	647-142W	1	FRAME SIDE RH.	19	D-3782	1	TAPERED BEARING SET
3	642-185W	1	FRONT AXLE (60" DECK)	20	F-1015-28	2	3/8-16 x 1-3/4" CAPSCREW
-	642-186W	1	FRONT AXLE (72" DECK)	21	D-3646	1	TAPERED ROLLER BRG.
4	642-019W	1	FRONT PIVOT CHANNEL	22	D-3647	1	SEAL, #19992
5	647-188W	1	MOTOR MOUNT WLDT.	23	F-1005-05	10	1/2" LOCK NUT
6	647-195P	1	SIDE PANEL RH.	24	F-1293	4	1/2-13 X 2" GR. 5
7	647-196P	1	SIDE PANEL LH.	25	F-1759	2	1/2-13 X 1" GR.5
8	647-123A	1	ENGINE GUARD REAR W/DECAL	26	F-1386	6	1/2-13 X 1-1/4" GR. 5
9	F-1005-03	2	3/8-16 STOVER NUT	27	F-1526	1	1/2-13 X 1-1/2" GR. 5
10	642-063P	4	DRAG BAR TAB	28	F-1073	1	3/8-16 X 2" GR. 5
11	642-042P	2	BRAKE ROD MOUNT	29	F-1011-03	2	3/8-16 NUT, UNC-2B
12	642-053P	1	SPRING ANCHOR	30	F-1558	10	3/8-16 X 7/8" GR. 5
13	606-303P	1	1" WASHER	31	P-12097	1	COUNTRY CLIPPER, DECAL
14	H-1924	1	GREASE CAP	32	647-137P	1	LEFT SIDE MOTOR GUARD
15	F-1239	11	3/8-16 LOCK NUT	33	647-136P	1	RIGHT SIDE MOTOR GUARD
16	F-1558	2	3/8-16 X 7/8", GR.5	34	D-3730	2	BUSHING, JOY STICK
17	F-1728	1	3/16 X 2" COTTER PIN				

FENDER ASSEMBLY

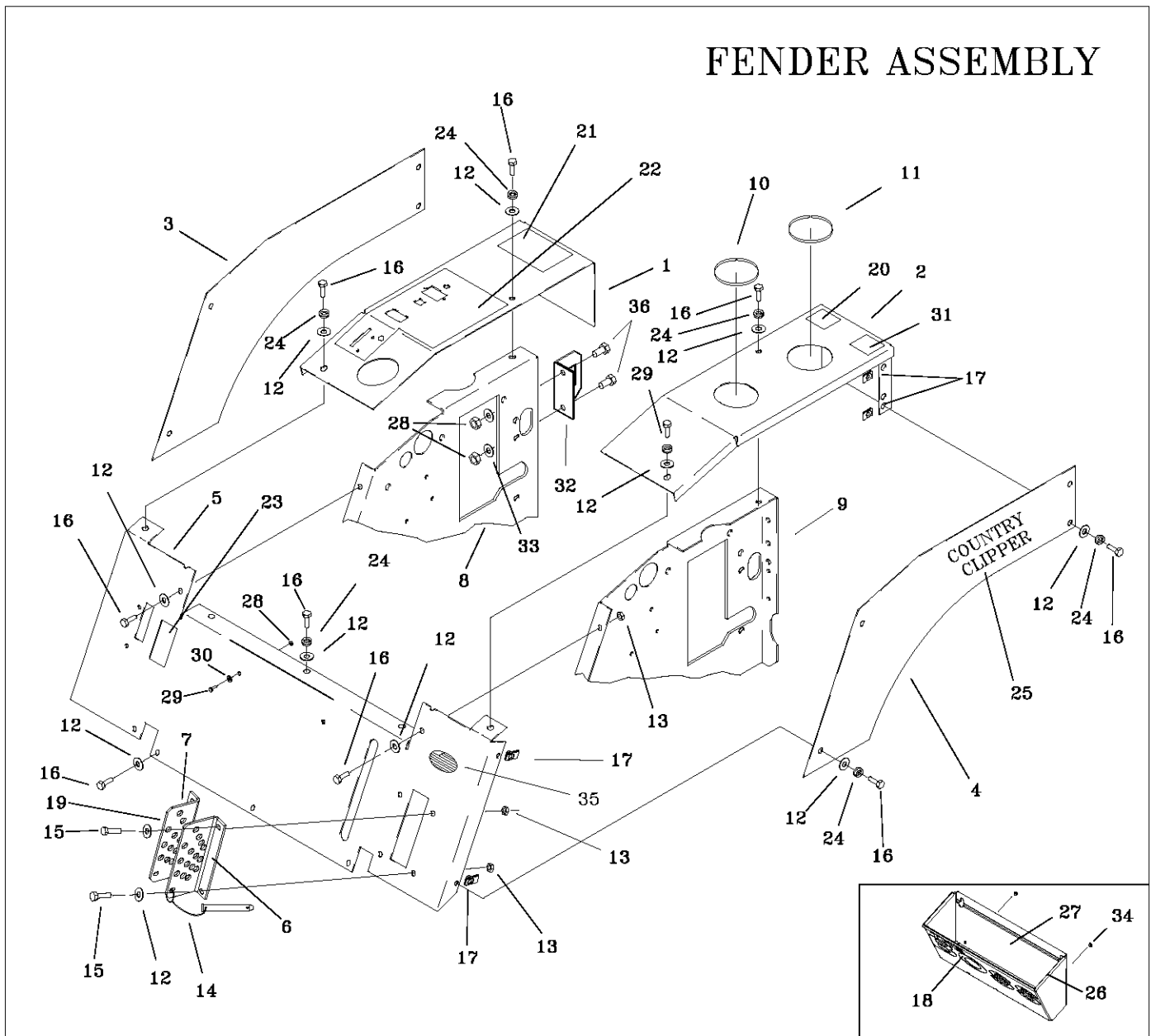

REF NO.	PART NO.	QTY.	DESCRIPTION	REF NO.	PART NO.	QTY.	DESCRIPTION
1	642-133A	1	FENDER CAP RH W/DECAL	17	F-1860	8	5/16 U-NUT
-	642-140A	-	FDR. CAP RH. 2 LEV. W/DECAL	18	P-12016	1	DECAL, THE BOSS
-	647-068A	-	FDR. CAP RH. W/EFI DECAL	19	P-12034	1	DECAL, "1/4 CUT HEIGHT"
-	647-067A	-	FDR. CAP RH. 2 LEV. W/EFI DECAL	20	P-12557	1	DECAL, "CAUTION"
2	642-170A	1	FENDER CAP LH. W/DECAL	21	P-11370	1	DECAL, "WARNING"
-	642-171A	-	FDR. CAP LH. 2 LEV. W/DECAL	22	P-11369	1	DECAL, RH. FENDER CAP
3	642-134A	1	FENDER SKIRT RH W/DECAL	23	P-11382	1	DECAL, PARK BRAKE
4	642-135A	1	FENDER SKIRT LH W/DECAL	24	F-1019-02	15	5/16 LOCK WASHER
5	647-116A	1	FRONT PANEL ASS'Y. W/DECAL	25	P-12097	2	DECAL, "COUNTRY CLIPPER"
-	642-057P	1	FRONT PANEL	26	H-1626	1	TRIM, TOOL TRAY
6	647-095P	1	LATCH PLATE LH.	27	647-110W	1	TOOL TRAY ASSEMBLY
7	647-097A	1	LATCH PLATE, RH, W/DECAL	28	F-1158	4	1/4-20 STOVER NUT
8	647-195P	1	SIDE PANEL RH.	29	F-1015-02	4	1/4-20 X 5/8" BOLT
9	647-196P	1	SIDE PANEL LH.	30	H-1989	2	SHOULDER WASHER
10	H-1626	1	TRIM, FUEL TANK	31	P-11052	2	DECAL, OIL
11	H-1626	1	TRIM, OIL TANK	32	647-146P	1	FUSE HOLDER
12	F-1009-02	28	5/16 FLAT WASHER	33	F-1009-01	2	1/4" FLAT WASHER
13	F-1125	16	5/16-18 LOCK NUT	34	H-2461	2	RUBBER BUMPER
14	F-2028	1	1/2" X 2.4 CLEVIS PIN W/SASH	35	P-12253	1	DECAL, MADE IN USA
15	F-1879	4	5/16-18 X 1-1/4" GR. 5	36	F-1538	2	1/4-20 x 3/4" CAPSCREW
16	F-1015-15	21	5/16-18 X 1" GR.5				

SEAT, FOOTDECK & RELATED PARTS

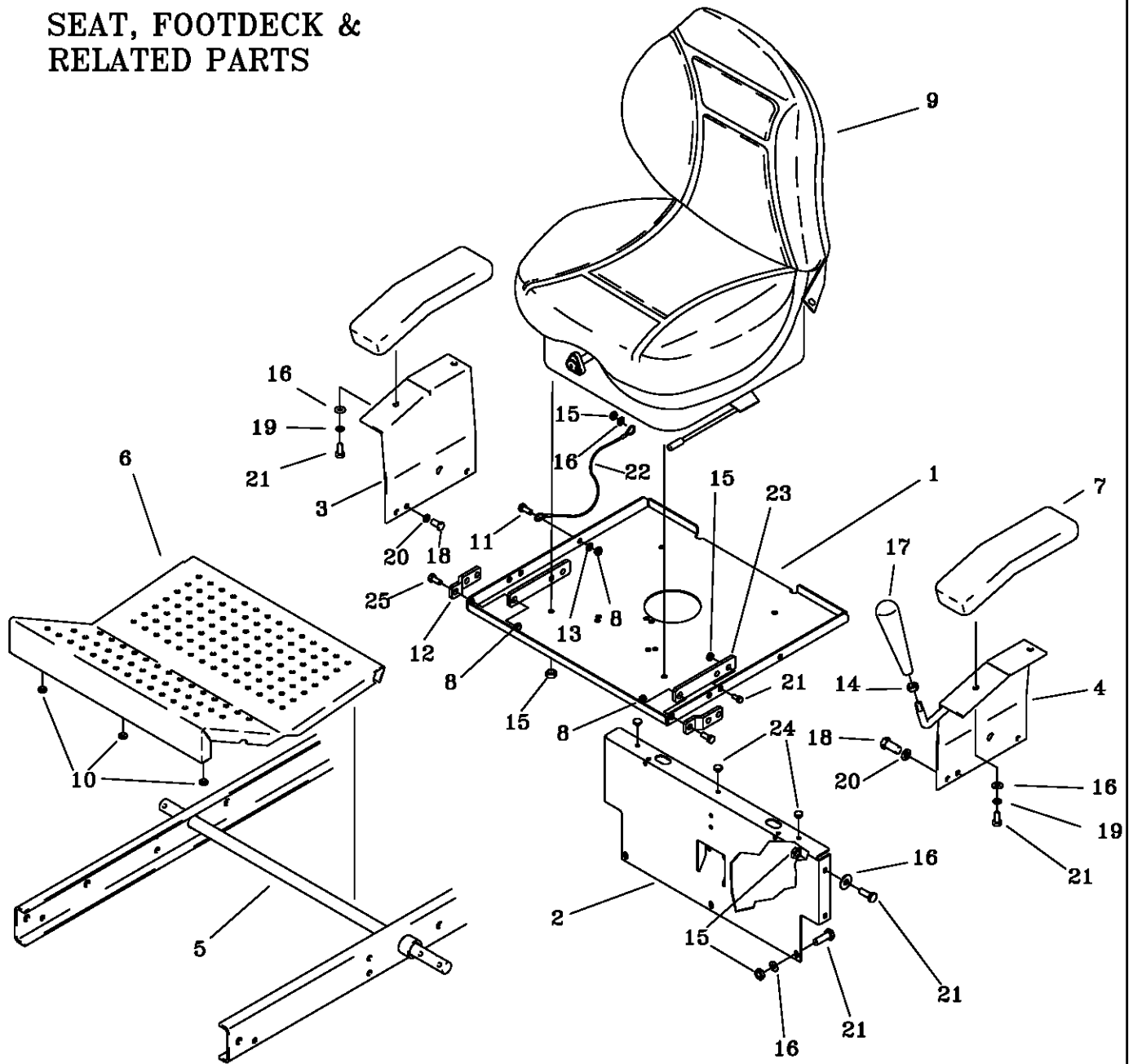

REF NO.	PART NO.	QTY.	DESCRIPTION	REF NO.	PART NO.	QTY.	DESCRIPTION
1	647-211P	1	SEAT BRACKET	14	F-1011-03	1	3/8-16 PLAIN NUT
2	647-088P	1	REAR BRACE	15	F-1005-02	16	5/16-18 LOCK NUT
3	647-212P	1	ARM REST RH. (JOYSTICK)	16	F-1009-02	12	5/16 FLAT WASHER
-	647-212P	1	ARM REST, (TWIN STICK)	17	H-2317	1	TAPERED GRIP BALL
4	647-214W	1	ARM REST LH. (JOYSTICK)	18	F-1755	4	3/8-16 X 1/2" GR. 5
-	647-213P	1	ARM REST, (TWIN STICK)	19	F-1019-02	4	5/16 LOCK WASHER
5	620-051P	1	LIFT BAR	20	F-1019-03	4	3/8 LOCK WASHER
6	642-044P	1	FOOT DECK	21	F-1546	16	5/16-18 X 3/4" GR. 5
7	H-2615	2	ARM REST PAD	22	H-2460	1	CABLE
8	F-1005-03	4	3/8-16 STOVER NUT	23	659-175P	2	SEAT HINGE TAB
9	H-2606	1	SEAT	24	H-2512	3	RUBBER BUMBERS
10	H-2461	3	RUBBER BUMPER	25	F-1307	2	3/8-16 x 1-1/4" CAPSCREW
11	F-1015-23	1	3/8-16 X 3/4" GR. 5				
12	647-086P	2	SEAT MTG TAB				
13	F-1009-03	2	3/8 FLAT WASHER				

FUEL INJECTION FUEL LINE ASSEMBLY

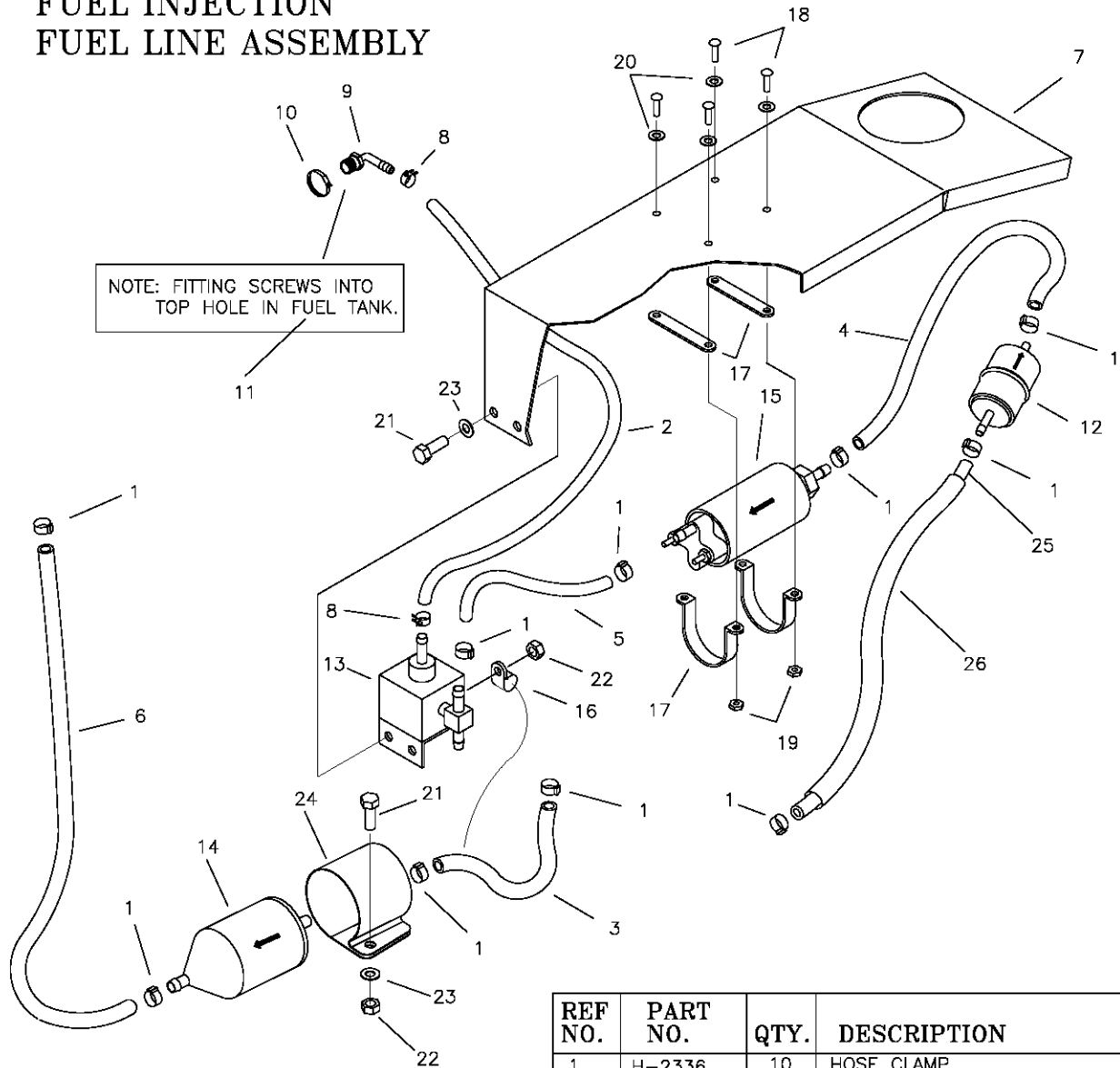

REF NO.	PART NO.	QTY.	DESCRIPTION
1	H-2336	10	HOSE CLAMP
2	647-063P	1	46" FUEL LINE, 1/4" ID
3	647-059P	1	8" FUEL LINE, 5/16" ID
4	H-2334	1	6-1/2" FUEL LINE
5	647-061P	1	6" FUEL LINE, 5/16" ID
6	647-062P	1	13" FUEL LINE, 5/16" ID
7	-	1	FENDER CAP RH
8	H-1687	2	HOSE CLAMP
9	H-1646	1	HOSE BARB
10	H-1952	1	HOSE CLAMP
11	647-058P	1	FUEL TANK FOR EFI
12	H-2335	1	FUEL FILTER
13	H-2339	1	REGULATOR
14	H-2338	1	FILTER, BOSCH
15	H-2340	1	FUEL PUMP
16	H-2337	1	LOOP CLAMP
17	H-2341	2	PUMP MOUNTING BANDS & BARS
18	F-1022-26	4	MACHINE SCREWS, 10-32 X 58"
19	F-1448	4	10-32 LOCK NUT
20	F-1071	4	FLAT WASHER
21	F-1538	3	1/4-20 X 3/4" GR 5
22	F-1158	3	1/4" LOCK NUT
23	F-1009-01	3	1/4" FLAT WASHER
24	629-651P	1	FUEL FILTER BRACKET (2")
25	H-2334	1	9" FUEL LINE
26	647-200P	1	8" SHEATH

FUEL TANK ASSEMBLY

647-202A

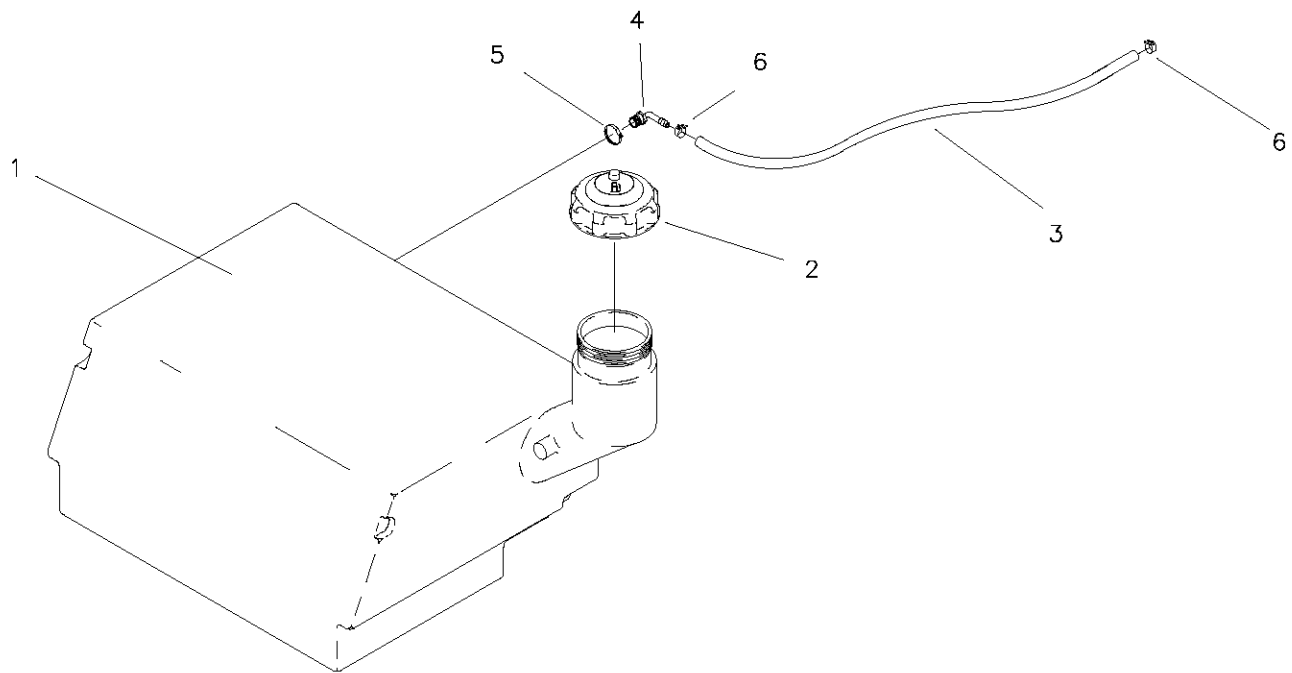

REF NO.	PART NO.	QTY.	DESCRIPTION
1	H-2234	1	11 GALLON TANK
2	H-2232	1	GAS CAP
3	H-1648	1	29-1/2" FUEL LINE
4	H-1646	1	HOSE BARB, 90 DEG.
5	H-1952	1	HOSE CLAMP
6	H-1687	2	HOSE CLAMP, 1/2"

JACK ASSEMBLY 629-653A

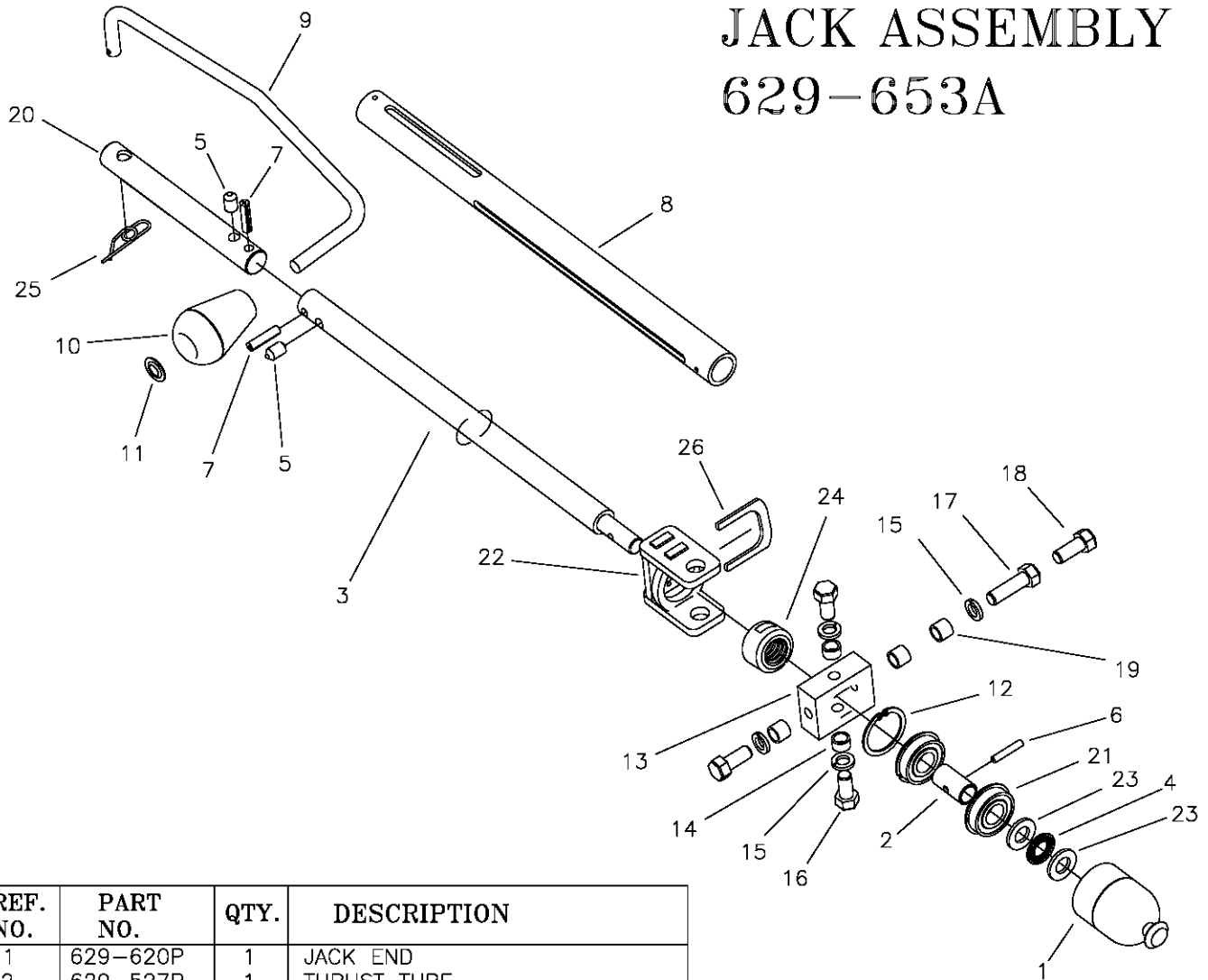

REF. NO.	PART NO.	QTY.	DESCRIPTION
1	629-620P	1	JACK END
2	629-527P	1	THRUST TUBE
3	629-528P	1	SHAFT, JACK
4	D-3675	1	THRUST BEARING 1/2 INCH ID
5	F-1120	2	BALL PLUNGER
6	F-1855	1	ROLL PIN, 3/16 X 1
7	F-1831	2	3/16 x 1" SPIROL PIN
8	629-529P	1	EXTENSION TUBE, JACK
9	629-216P	1	CRANK HANDLE
10	H-2343	1	KNOB
11	F-1913	1	PUSH RETAINER 3/8 INCH
12	F-2015	1	SNAP RING 1 3/8 INTERNAL
13	629-531P	1	JACK BASE PLATE, TIPPED
14	629-549P	2	SPACER
15	F-1019-03	4	3/8" LOCKWASHER
16	F-1015-23	2	3/8-16 x 3/4" CAPSCREW
17	F-1307	1	3/8-16 x 1-1/4" CAPSCREW
18	F-1558	2	3/8-16 x 7/8" CAPSCREW
19	629-532P	3	SPACER
20	629-564P	1	UPPER HANDLE EXTENSION
21	D-3432	2	BEARING 5/8" I.D. 1-3/8" O.D.
22	629-621W	1	YOKE WELDMENT
23	D-3814	2	BEARING THRUST WASHER .50 ID
24	629-648P	1	3/4-6 ACME NUT (NICKEL)
25	F-1492	1	5/16-3/8 RUE RING
26	629-647	1	KEEPER

JOYSTICK HD STEERING CONTROL AND RELATED PARTS 647-100A

NOTE; ITEM'S #2 AND #3 MUST BE REPLACED AT THE SAME TIME FOR MAXIMUM PERFORMANCE.

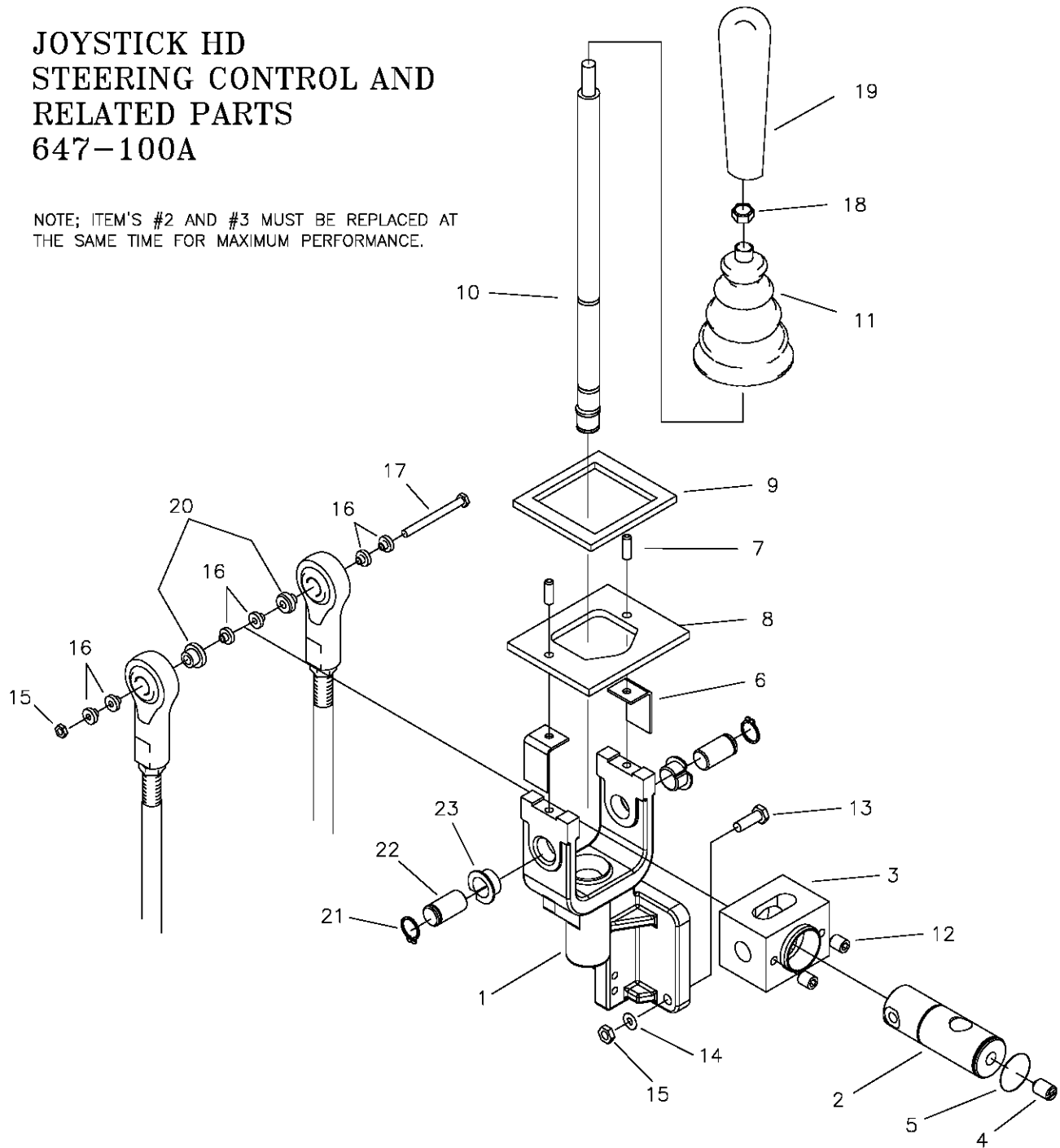

REF NO.	PART NO.	QTY.	DESCRIPTION	REF NO.	PART NO.	QTY.	DESCRIPTION
1	647-105P	1	JOYSTICK YOKE	13	F-1015-05	3	1/4-20 X 1" HHCS GR. 5
2	647-104P	1	PIVOT SHAFT	14	F-1019-01	3	1/4" LOCK WASHER
3	647-101P	1	PIVOT BLOCK	15	F-1158	4	1/4-20 LOCK NUT
4	F-1120	1	BALL PLUNGER	16	H-1989	6	BUSHING, BALL JOINT
5	F-1998	1	SNAP RING, SPIRLOCK	17	F-1765	1	1/4-20 X 3" GR. 5
6	647-106P	2	RETAINING PLATE	18	F-1011-03	1	3/8-16 NUT, JAM
7	F-1999	2	ROLL PIN	19	H-2317	1	HANDLE GRIP, TAPERED
8	659-129P	1	JOYSTICK TOP PLATE	20	H-2465	2	1/4" SPACER
9	H-1947	1	GASKET, FOAM	21	F-1740	2	SNAP RING
10	621-140A	1	JOYSTICK SHAFT ASSEMBLY	22	647-103P	2	PIVOT PIN
11	H-1991	1	BOOT	23	D-3784	2	BUSHING
12	F-1228	2	1/4-28 SET SCREW				

JOYSTICK STEERING CONTROL AND RELATED PARTS (continued)

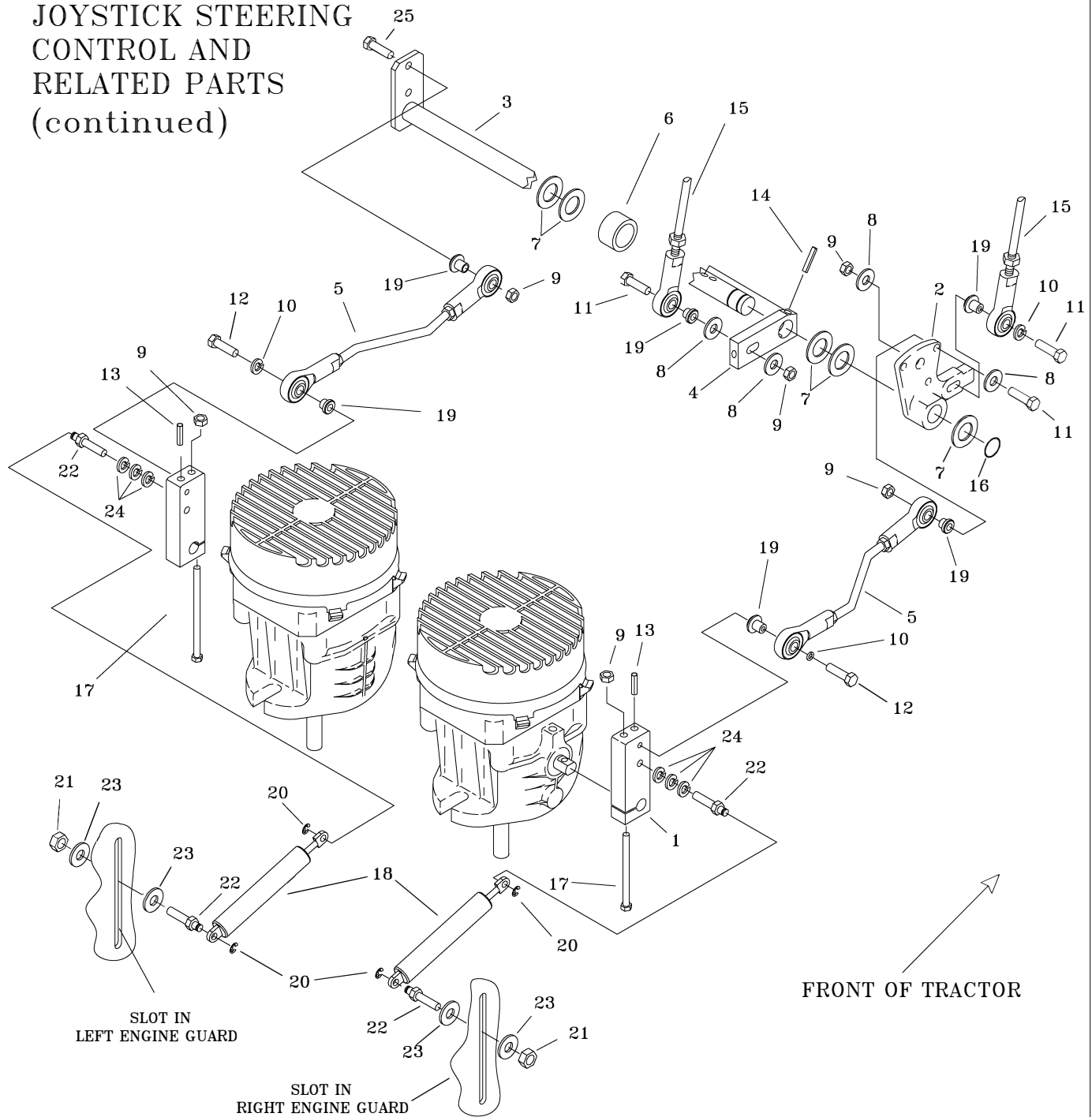

REF NO.	PART NO.	QTY.	DESCRIPTION	REF NO.	PART NO.	QTY.	DESCRIPTION
1	647-189P	2	SHIFT ARM	14	F-1503	2	ROLL PIN, 3/16" X 1"
2	638-027A	1	LINKAGE DISK ASSEMBLY	15	647-082P	2	LOWER LINKAGE
3	636-078W	1	SHIFT ROD	16	F-1739	1	SPIROL RING
4	625-030P	2	SWIVEL ARM	17	F-1020-07	2	1/4-20 X 4" BOLT
5	647-083P	2	UPPER LINKAGE ROD	18	H-2467	2	DUAL ACTION DAMPER, LIGHT
6	647-197P	2	SPACER	19	H-2465	6	1/4 X 5/16 SHOULDER WASHER
7	610-103P	5	THRUST WASHER	20	F-1610	4	E-RING
8	F-1009-01	4	1/4" FLAT WASHER	21	F-1125	2	5/16-18 LOCK NUT
9	F-1158	6	1/4-20 LOCK NUT	22	638-028P	4	5/16-18 DAMPER BOLT
10	F-1019-01	2	1/4-20 LOCK WASHER	23	F-1009-02	4	5/16 FLAT WASHER
11	F-1716	2	1/4-20 X 1-1/2", GR.5	24	F-1019-02	6	5/16 LOCK WASHER
12	F-1015-05	3	1/4-20 X 1" GR. 5	25	F-1539	1	1/4-20 x 1-1/4" CAPSCREW
13	F-1725	2	ROLL PIN, 5MM X 26MM				

RIGHT HAND STEERING CONTROL AND RELATED PARTS (636-168A)

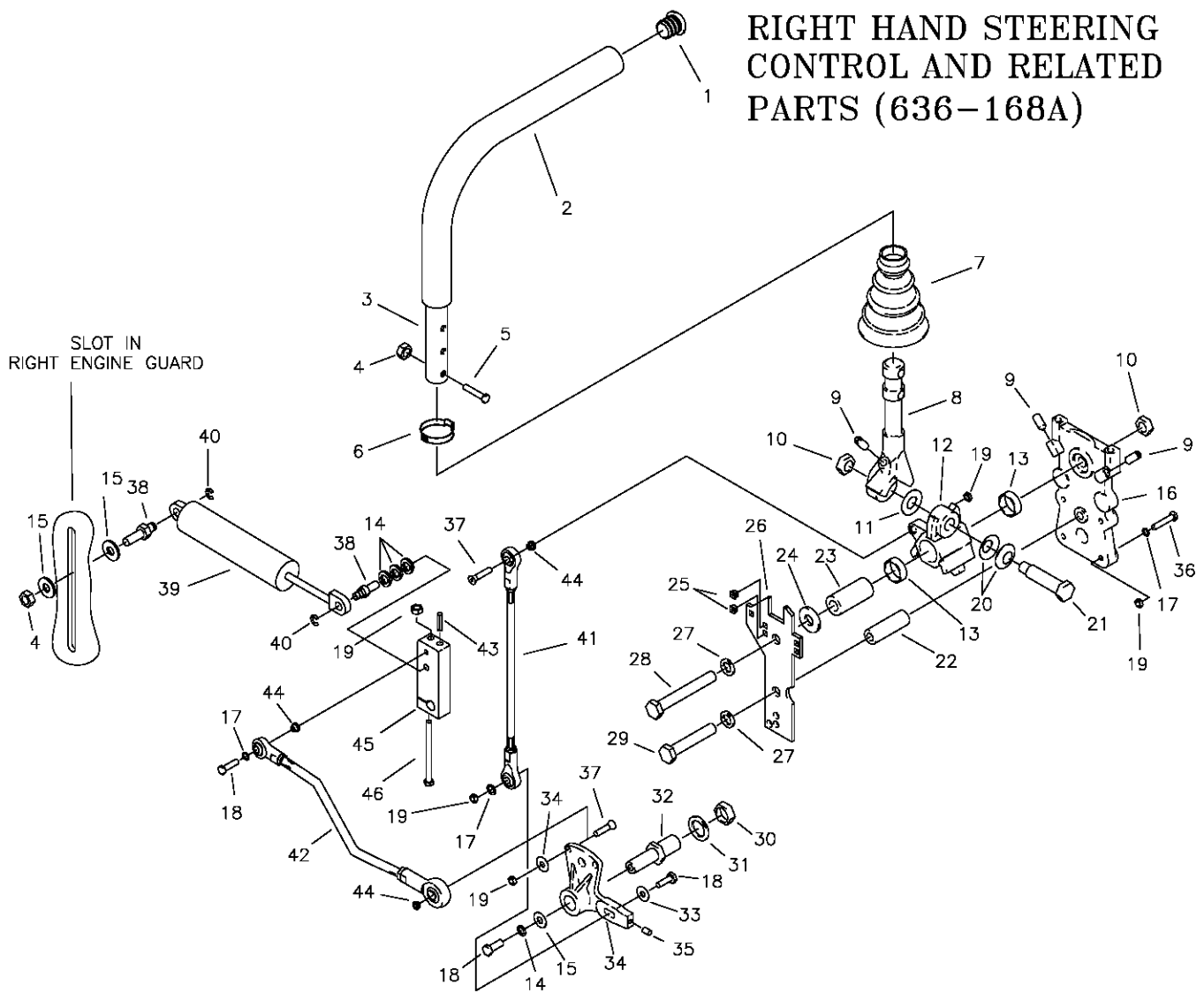

REF NO.	PART NO.	QTY.	DESCRIPTION	REF NO.	PART NO.	QTY.	DESCRIPTION
1	H-2080	1	END PLUG, 15/16" BLACK	26	636-167P	1	SIDE PLATE, DUALEVER
2	H-2079	1	FOAM GRIP, 17"	27	F-1464	2	1/2" LOCK WASHER
3	636-170P	1	CONTROL LEVER	28	F-1828	1	1/2-13 X 3-1/2" HHCS GR. 5
4	F-1125	2	5/16 LOCK NUT	29	F-1439	1	1/2-13 X 3" HHCS GR. 5
5	F-1879	2	5/16-18 X 1-1/4" HHCS GR. 5	30	F-1011-07	1	3/4-10 PLAIN NUT
6	H-2089	1	HOSE CLAMP, 1-1/4"	31	F-1463	1	3/4" LOCK WASHER
7	H-2081	1	BOOT, TAPERED 1" CUFF	32	623-048P	1	LINKAGE PINTLE
8	625-063P	1	LEVER, DUALEVER	33	F-1009-01	2	1/4" FLAT WASHER
9	F-1842	3	SETSCREW, 5/16-18 X 3/4"	34	638-027A	1	LINKAGE DISK ASSEMBLY
10	F-1489	2	1/2-13 JAM NUT	35	F-1695	1	SETCREW, 1/4-20 X 3/8"
11	H-2116	1	WASHER, FIBER	36	F-1539	3	1/4-20 X 1-1/4" HHCS GR. 5
12	638-033P	1	PIVOT BLOCK, DUALEVER	37	F-1974	2	1/4-20 X 1-1/4" FLAT HEAD
13	D-3622	2	BEARING	38	638-028P	2	5/16 DAMPER BOLT
14	F-1019-02	4	5/16" LOCK WASHER	39	H-2168	1	STEERING DAMPER
15	F-1009-02	3	WASHER, FLAT STD. 5/16"	40	F-1610	1	E-RING FOR 1/4" SHAFT
16	638-034P	1	BASE DUALEVER	41	647-082P	1	UPPER LINKAGE
17	F-1019-01	5	1/4" LOCK WASHER	42	647-083P	1	LOWER LINKAGE
18	F-1015-14	3	1/4-20 X 1" HHCS GR. 5	43	F-1725	1	ROLL PIN, 5MM X 26MM
19	F-1158	5	1/4-20 LOCK NUT	44	H-2465	3	1/4 X 5/16 SHOULDER WASHER
20	H-2115	2	WASHER, SPRING	45	647-189P	1	SHIFT ARM
21	625-070P	1	SHOULDER BOLT, 5/8" OD	46	F-1020-07	1	1/4-20 X 4" BOLT
22	625-067P	1	BUSHING, STAND OFF				
23	625-064P	1	BUSHING, PIVOT BLOCK				
24	625-072P	1	WASHER, FLAT				
25	F-1995	2	GROMMET, #10, SR-1200				

LEFT HAND STEERING CONTROL AND RELATED PARTS (636-169A)

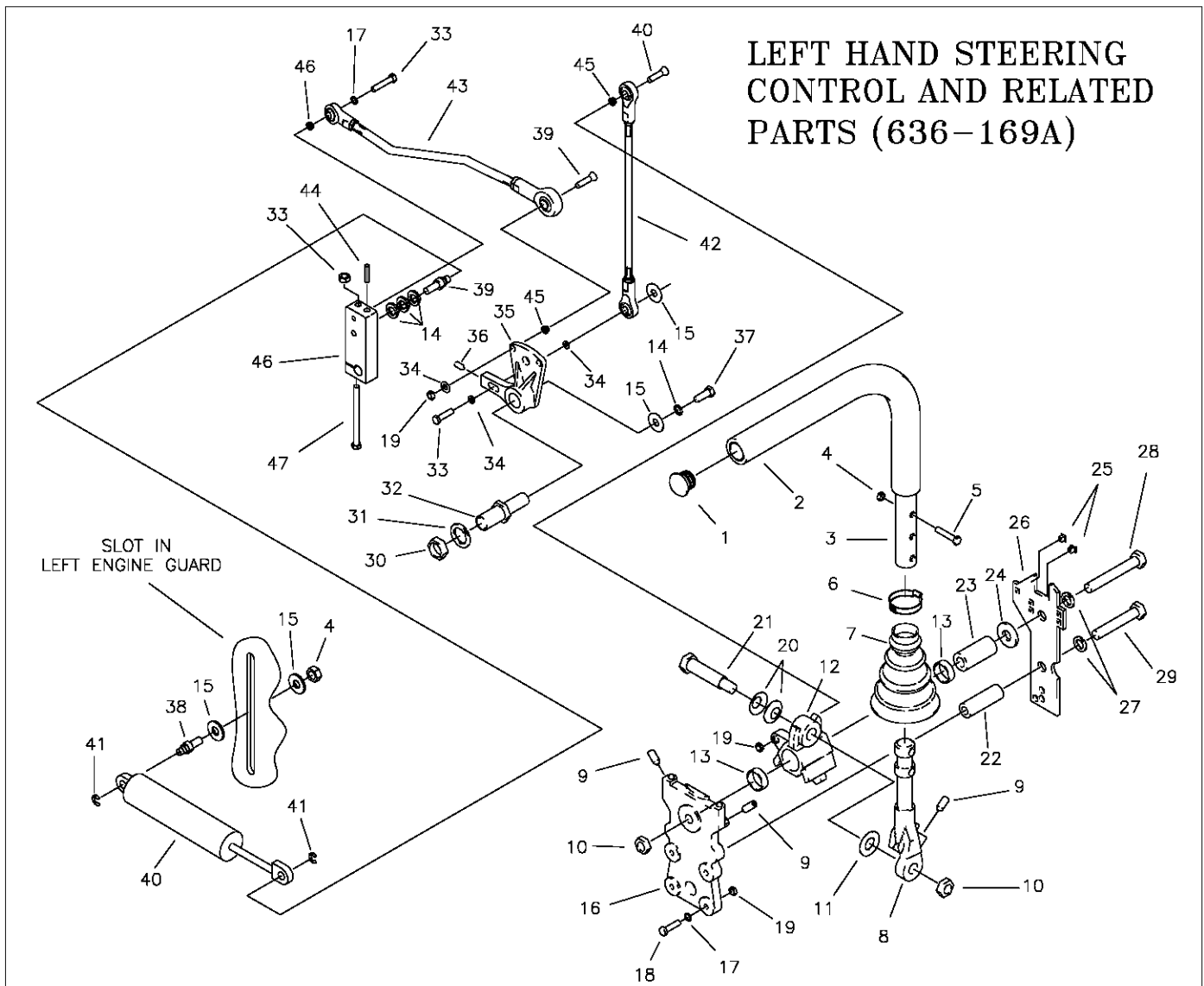

REF NO.	PART NO.	QTY.	DESCRIPTION	REF NO.	PART NO.	QTY.	DESCRIPTION
1	H-2080	1	END PLUG, 15/16" BLACK	26	636-167P	1	SIDE PLATE, DUALEVER
2	H-2079	1	FOAM GRIP, 17"	27	F-1464	2	1/2" LOCK WASHER
3	636-170P	1	CONTROL LEVER	28	F-1828	1	1/2-13 X 3-1/2" HHCS GR. 5
4	F-1125	3	5/16 LOCK NUT	29	F-1439	1	1/2-13 X 3" HHCS GR. 5
5	F-1879	2	5/16-18 X 1-1/2" HHCS GR. 5	30	F-1011-07	1	3/4-10 PLAIN NUT
6	H-2089	1	HOSE CLAMP 1-1/4"	31	F-1463	1	3/4" LOCK WASHER
7	H-2081	1	BOOT, TAPERED 1" CUFF	32	623-048P	1	LINKAGE PINTLE
8	625-063P	1	LEVER, DUALEVER	33	F-1716	1	1/4-20 X 1-1/2" HHCS GR. 5
9	F-1842	3	SETSCREW, 5/16-18 X 3/4"	34	F-1009-01	4	1/4" FLAT WASHER
10	F-1489	2	1/2-13 JAM NUT	35	638-027A	1	LINKAGE DISK ASSEMBLY
11	H-2116	1	WASHER, FIBER	36	F-1695	1	SETCREW, 1/4-20 X 3/8"
12	638-033P	1	PIVOT BLOCK, DUALEVER	37	F-1015-14	1	5/16-18 X 7/8" HHCS GR. 5
13	D-3622	2	BEARING	38	638-028P	1	DAMPER BOLT, 5-16-18 X 3/4"
14	F-1019-02	4	5/16" LOCK WASHER	39	F-1974	2	1/4-20 X 1-1/4" SOCK BOLT
15	F-1009-02	3	WASHER, FLAT STD. 5/16"	40	H-2168	1	STEERING DAMPER
16	638-034P	1	BASE DUALEVER	41	F-1610	2	E-RING FOR 1/4" SHAFT
17	F-1019-01	4	1/4" LOCK WASHER	42	647-082P	1	UPPER LINKAGE
18	F-1539	3	1/4-20 X 1-1/4" HHCS GR. 5	43	647-083P	1	LOWER LINKAGE
19	F-1158	4	1/4-20 LOCK NUT	44	F-1725	1	ROLL PIN 5MM X 26MM
20	H-2115	2	WASHER, SPRING	45	H-2465	3	1/4" SHOULDER WASHER
21	625-070P	1	SHOULDER BOLT, 5/8" OD	46	647-189P	1	SHIFT ARM
22	625-067P	1	BUSHING, STAND OFF	47	F-1020-07	1	1/4-20 X 4" BOLT
23	625-064P	1	BUSHING, PIVOT BLOCK				
24	625-072P	1	WASHER, FLAT				
25	F-1995	2	GROMMET, #10,				

PARKING BRAKE ASSEMBLY & RELATED PARTS

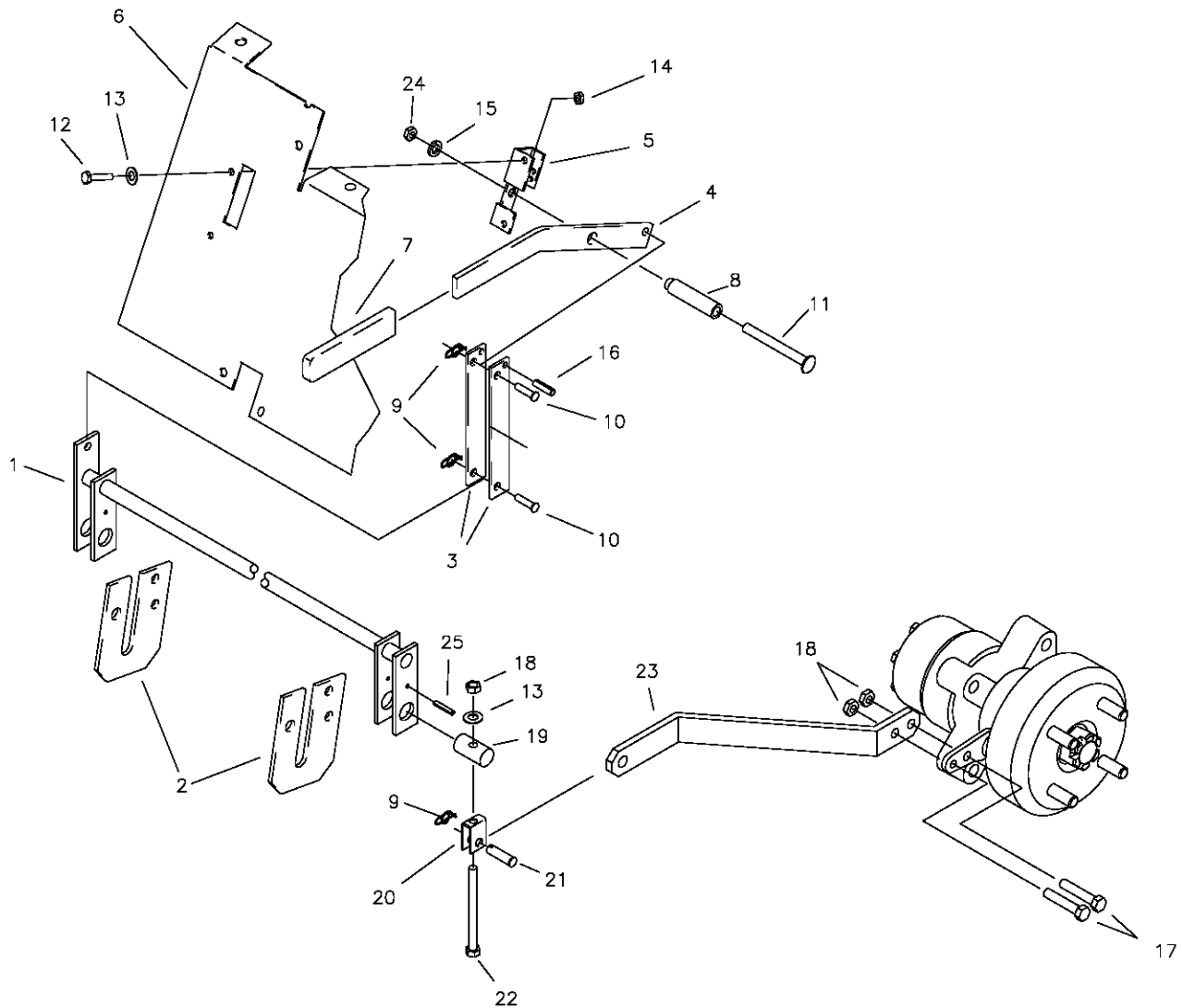

REF NO.	PART NO.	QTY.	DESCRIPTION	REF NO.	PART NO.	QTY.	DESCRIPTION
1	647-014W	1	BRAKE ROD WELDMENT	17	F-1015-15	4	5/16-18 X 1" BOLT
2	642-042P	2	BRAKE ROD MOUNT	18	F-1125	6	5/16-18 LOCK NUT
3	642-058P	2	BRAKE LINK	19	642-067P	2	TOP HANGER PIN
4	642-056P	1	BRAKE HANDLE	20	647-030P	2	BRAKE YOKE LINKAGE
5	642-054P	1	BRAKE SWITCH BRACKET	21	F-1444	2	CLEVIS PIN 3/8 X 1-5/16"
6	642-057P	1	FRONT PANEL	22	F-1153	2	5/16-18 X 4.5" GR. 5
7	H-1926	1	HANDLE GRIP	23	647-145P	2	BRAKE ARM
8	642-027P	1	BRAKE PIVOT TUBE	24	F-1005-03	1	3/8-16 LOCK NUT
9	F-1492	3	RUE RING	25	F-1604	2	ROLL PIN
10	F-1443	2	5/16" PIN				
11	F-1982	1	3/8-16 X 3-1/2" CARRIAGE				
12	F-1538	2	1/4-20 X 3/4" GR. 5				
13	F-1009-01	4	1/4" FLAT WASHER				
14	F-1005-01	2	1/4-20 LOCK NUT				
15	F-1019-03	1	3/8" LOCK WASHER				
16	F-1831	2	1/4 X 1" ROLL PIN				

GEAR MOTOR, WHEEL ASSEMBLY

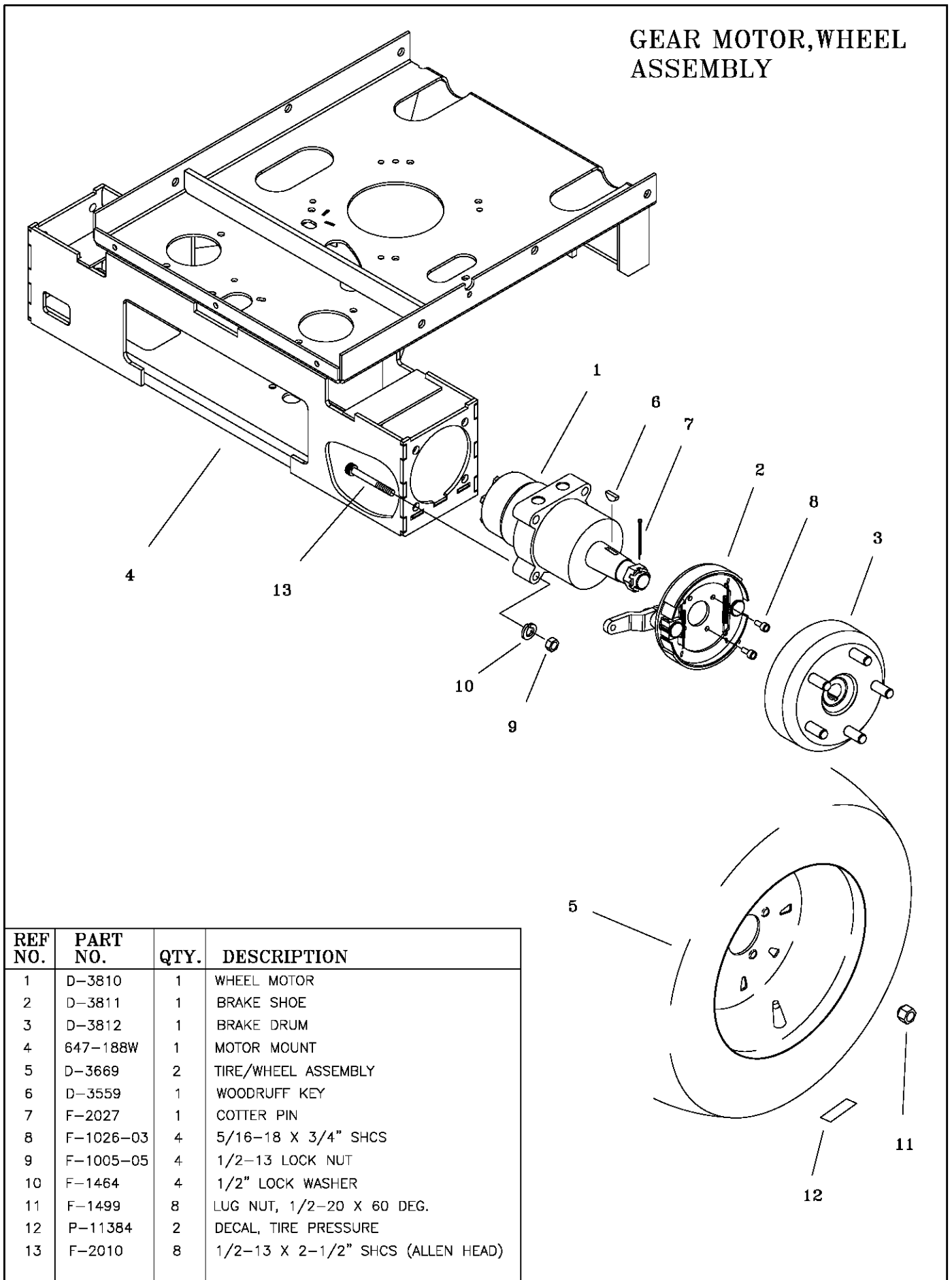

REF NO.	PART NO.	QTY.	DESCRIPTION
1	D-3810	1	WHEEL MOTOR
2	D-3811	1	BRAKE SHOE
3	D-3812	1	BRAKE DRUM
4	647-188W	1	MOTOR MOUNT
5	D-3669	2	TIRE/WHEEL ASSEMBLY
6	D-3559	1	WOODRUFF KEY
7	F-2027	1	COTTER PIN
8	F-1026-03	4	5/16-18 X 3/4" SHCS
9	F-1005-05	4	1/2-13 LOCK NUT
10	F-1464	4	1/2" LOCK WASHER
11	F-1499	8	LUG NUT, 1/2-20 X 60 DEG.
12	P-11384	2	DECAL, TIRE PRESSURE
13	F-2010	8	1/2-13 X 2-1/2" SHCS (ALLEN HEAD)

**HIGH PRESSURE
LINES & FITTINGS
FOR 60 & 72" BOSS**

H-2574 PLUMBING KIT

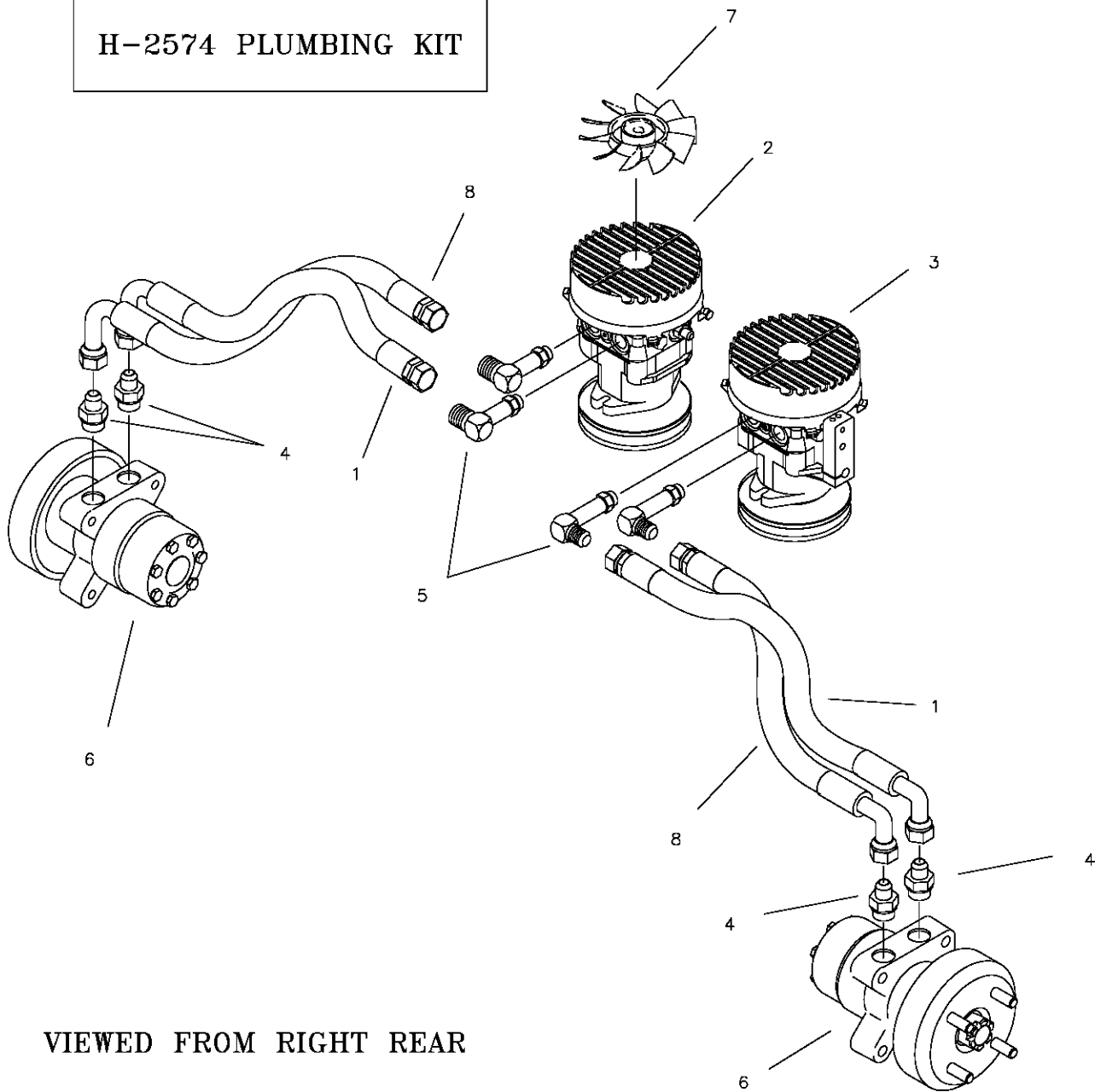

VIEWED FROM RIGHT REAR

REF NO.	PART NO.	QTY.	DESCRIPTION
1	H-2492	2	HOSE ASS'Y. 16-1/2"
2	D-3780-01	1	HYDRO PUMP, 12CC LH
3	D-3780-02	1	HYDRO PUMP, 12CC RH
4	H-2436	4	FITTING, STRAIGHT
5	H-2496	4	FITTING, 90°
6	-	2	SEE PAGE 25
7	D-3804	2	REPLACEMENT FAN BLADE
8	H-2576	2	HOSE ASS'Y. 11"

MOTOR ASSEMBLY & RELATED PARTS

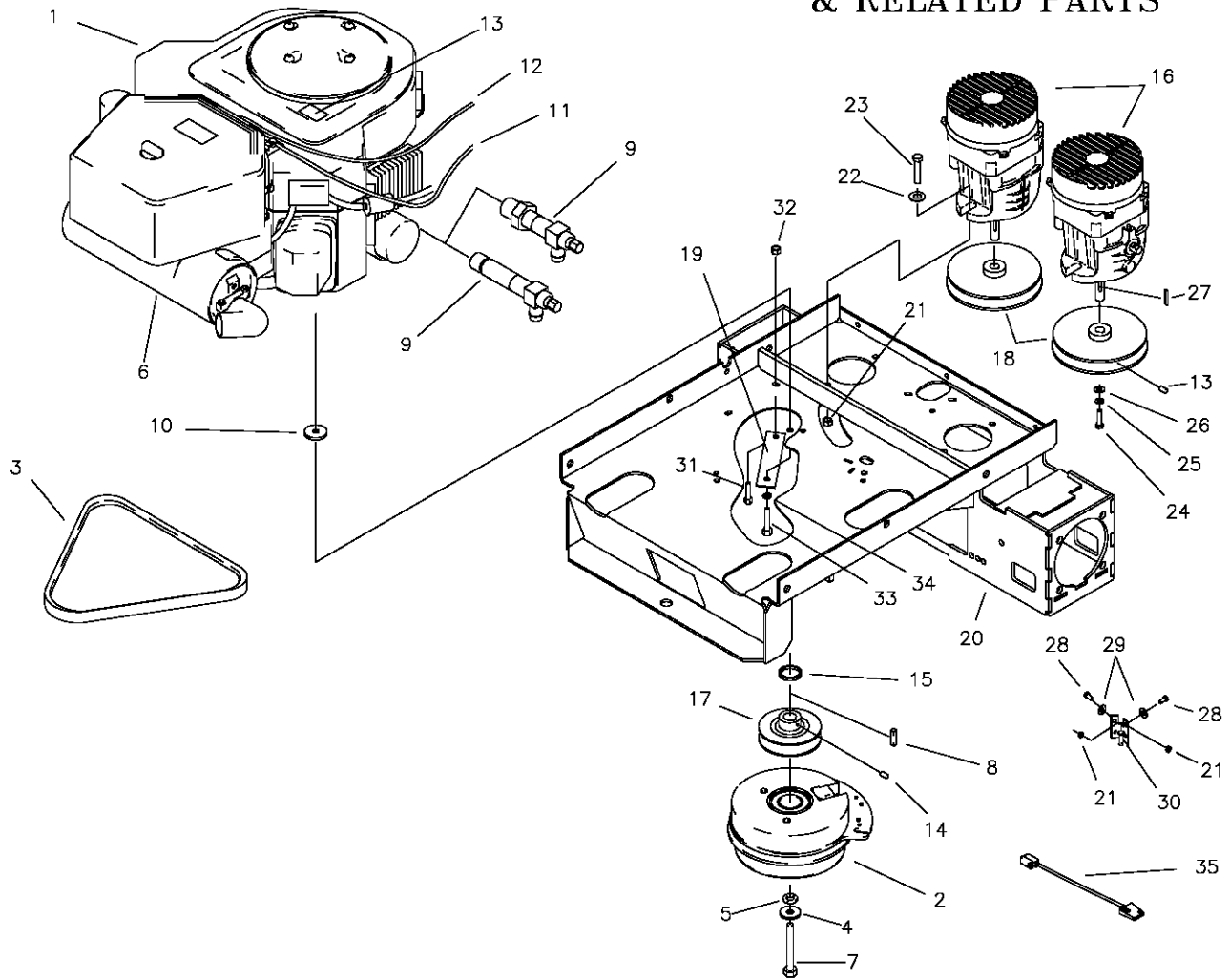

REF NO.	PART NO.	QTY.	DESCRIPTION	REF NO.	PART NO.	QTY.	DESCRIPTION
1	ENGINE	1	SEE PAGE 26	23	F-1307	4	3/8-16 X 1-1/4" GR. 5
2	CLUTCH	1	SEE PAGE 26	24	F-1737	2	6MM X 16MM GR. 5
3	D-3799	1	HYDRO PUMP BELT	25	F-1738	2	6MM WASHER
4	606-347P	1	WASHER	26	F-1736	2	LOCK WASHER
5	F-1019-04	1	7/16 LOCK WASHER	27	D-3541	2	KEY, 5MM.
6	MUFFLER	1	SEE PAGE 26	28	F-1015-02	2	1/4-20 X 5/8" BOLT GR. 5
7	BOLT	1	SEE PAGE 26	29	F-1009-01	2	1/4" FLAT WASHER
8	621-113P	1	KEY, 1/4 SQ. X 1-1/4"	30	659-015W	1	CLUTCH STOP WELDMENT
9	H-2589	1	OIL DRAIN (KOHLEK)	31	F-1015-15	1	5/16-18 X 1" BOLT
-	H-2590	1	OIL DRAIN (KAWASAKI)	32	F-1125	-	5/16-18 STOVER NUT
10	609-034P	-	ENGINE SPACER	33	BOLT	-	SEE PAGE 26
11	SEE PG. 27	1	CHOKE CABLE	34	F-1019-03	-	3/8 LOCK WASHER
12	SEE PG. 27	1	THROTTLE CABLE	35	E-6459	1	CLUTCH WIRE
13	P-10077	1	DECAL, "CLEAN"				
14	F-1228	3	SETSCREW, 1/4" X 1/4"				
15	611-143P	-	PULLEY SPACER				
16	HYD PUMP	2	SEE PAGE 24				
17	647-148P	1	MOTOR PULLEY				
18	647-147P	2	HYDRO PUMP PULLEY				
19	647-085P	1	GROUND STRAP				
20	647-188W	1	MOTOR MOUNT				
21	F-1158	8	1/4-20 STOVER NUT				
22	F-1009-03	8	3/8 FLAT WASHER				

ENGINE & CLUTCH MOUNTING HARDWARE

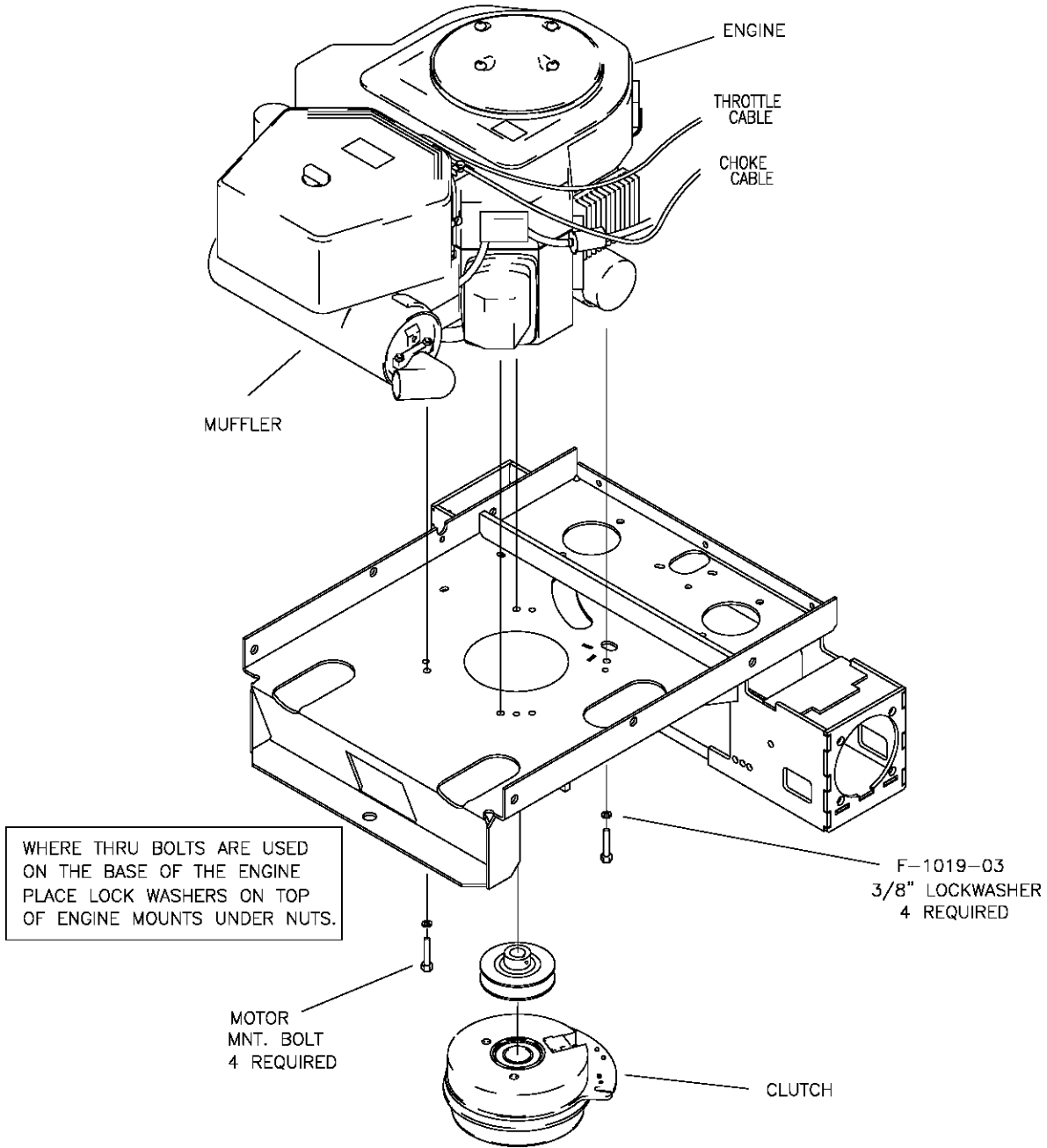

PART NO.	ENGINE	CLUTCH	MUFFLER	MOTOR MOUNT BOLTS	CLUTCH BOLT	THROTTLE CABLE	CHOKE CABLE
M-5348	26 HP KAW. LQ.	E-6444	H-2474	F-1979 8MM X 1-1/4" BOLTS	F-1981	H-2612	H-2287
M-5335	27 HP KOHLER	E-6444	-	F-1015-17 5/16 X 1-1/2" G5 BOLT	F-1545	H-2612	H-2404
M-5360	37 HP KAWASAKI	E-6425	H-2544	F-1307 3/8-16 X 1-1/4" G5 BOLTS	F-1904	H-2611	H-2404

MOTOR TO PUMPS SINGLE IDLER & BELT TIGHTENER

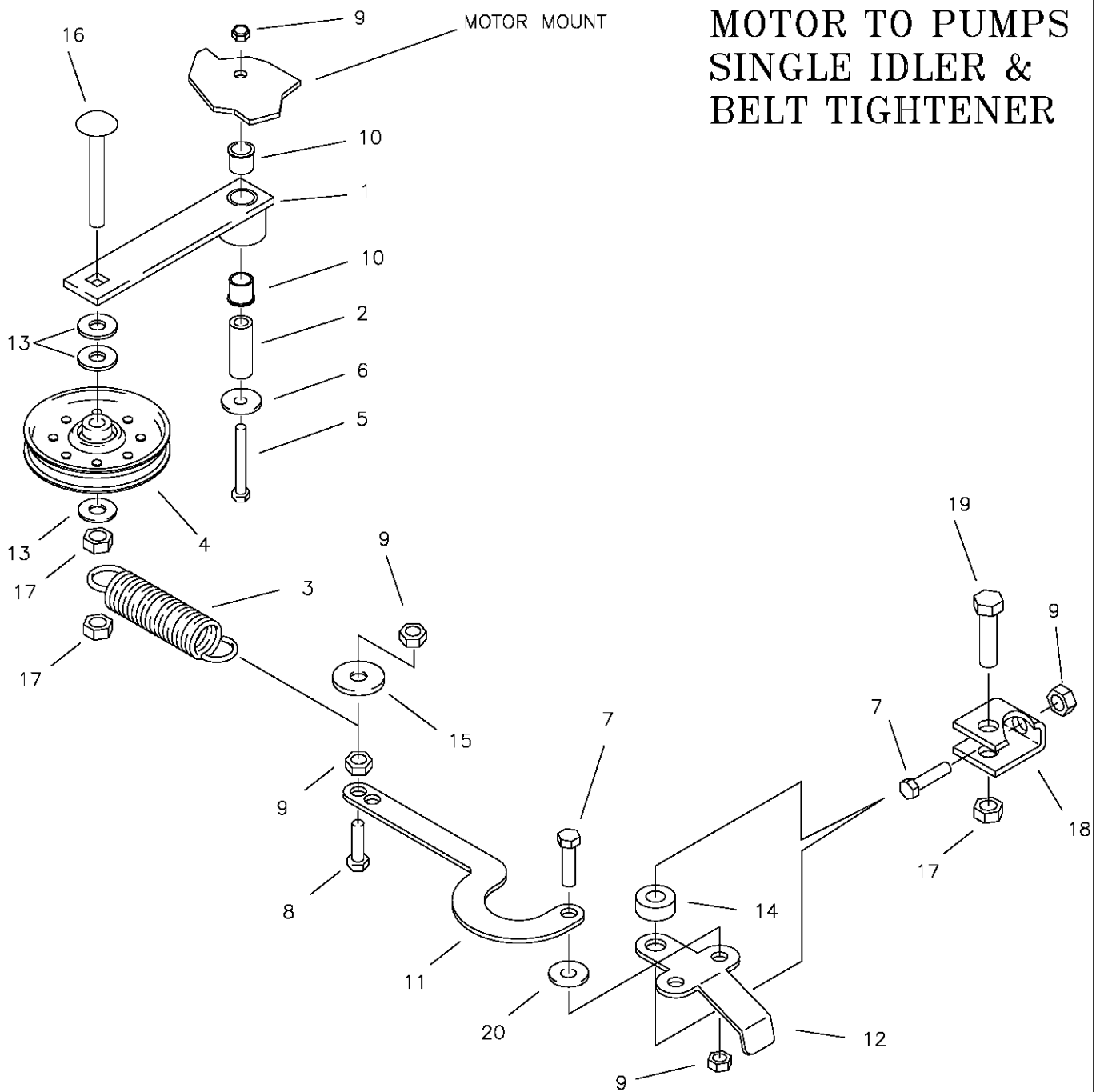

REF NO.	PART NO.	QTY.	DESCRIPTION	REF NO.	PART NO.	QTY.	DESCRIPTION
1	661-090A	1	SINGLE IDLER ASSEMBLY	15	609-034P	1	HEAVY WASHER
2	621-103P	1	MOUNTING PIN	16	F-1927	1	1/2-13 X 2-3/4" CARRIAGE BOLT
3	H-2092	1	SPRING	17	F-1005-05	3	1/2" LOCK NUT
4	D-3774	1	FLAT IDLER PULLEY	18	661-015P	1	SHACKLE
5	F-1820	1	5/16-18 X 2-1/4" HHCS GR. 5	19	F-1526	1	1/2-13 X 1-1/2" BOLT
6	F-1009-02	1	5/16" FLAT WASHER	20	F-1009-03	1	3/8" FLAT WASHER
7	F-1694	2	3/8-16 X 1" HHCS GR. 5				
8	F-1307	1	3/8-16 X 1-1/4" HHCS GR. 5				
9	F-1005-03	5	3/8-16 LOCK NUT				
10	D-3730	2	5/8 BORE BUSHING				
11	660-031P	1	ARM, BELT TIGHTENER				
12	660-030P	1	HANDLE, BELT TIGHTENER				
13	F-1521	3	1/2" FLAT WASHER				
14	660-038P	1	3/8" THICK SPACER				

OIL RETURN LINES & COOLER ASSEMBLY

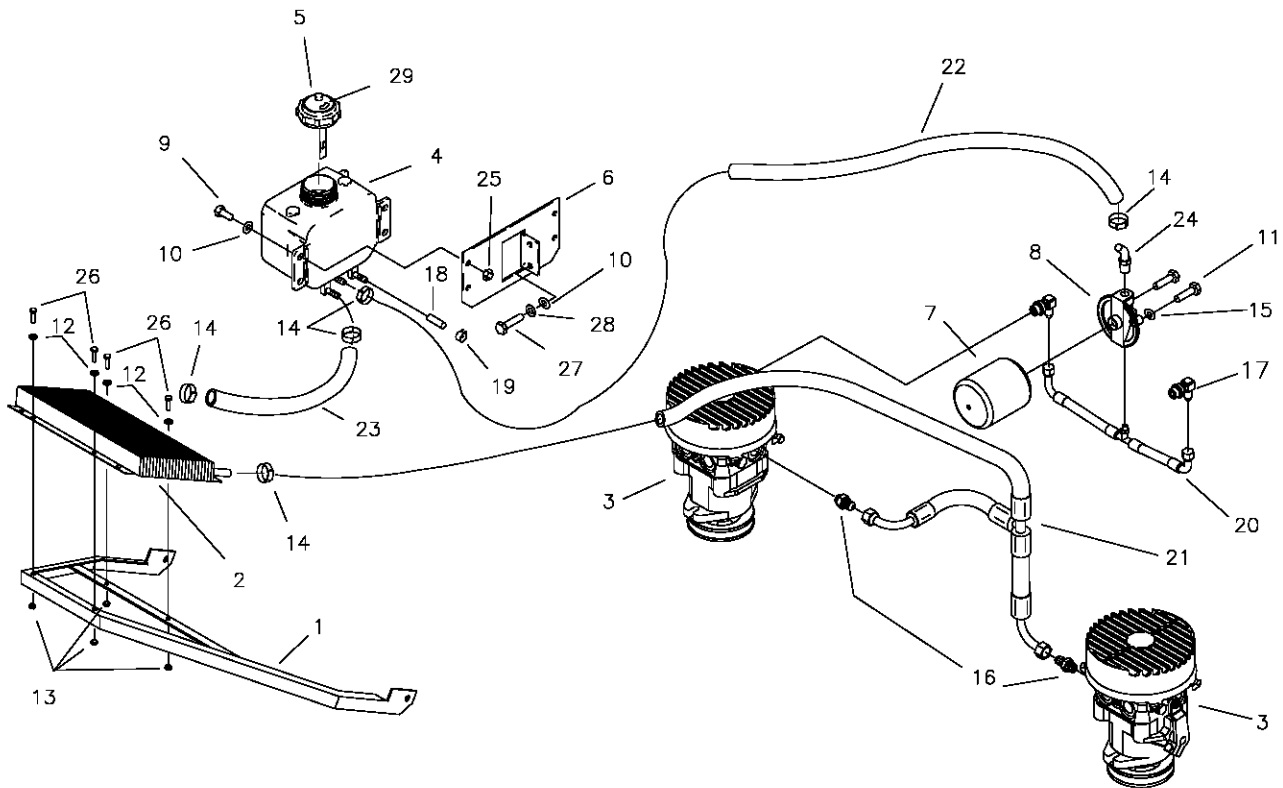

REF NO.	PART NO.	QTY.	DESCRIPTION	REF NO.	PART NO.	QTY.	DESCRIPTION
1	647-046W	1	BRACKET, OIL COOLER	18	H-2327	1	CAPLUG, 3/8 X 1"
2	H-2325	1	OIL COOLER	19	H-1687	1	HOSE CLAMP
3	-	-	SEE PAGE 24	20	H-2479	1	HOSE, SUCTION
4	H-2230	1	TANK, 2 QUART	21	H-2480	1	HOSE, RETURN
5	H-2120	1	CAP, HYDRO TANK	22	H-2438	1	HOSE, 24" HI-TEMP
6	642-052P	1	TANK MOUNT BRACKET	23	H-2478	1	HOSE, 18" HI-TEMP
7	H-2026	1	FILTER, HYDRO	24	H-1859	1	1/4 PIPE & HOSE BARB 90°
8	H-2061	1	FILTER BASE	25	F-1125	4	5/16-18 STOVER NUT
9	F-1546	4	5/16 X 3/4 GR. 5	26	F-1538	4	1/4-20 X 3/4" GR. 5
10	F-1009-02	6	5/16 FLAT WASHER	27	F-1394	2	3/8-16 X 1" CAPSCREW
11	F-1015-05	2	1/4-20 X 1" GR. 5	28	F-1019-03	2	3/8 LOCKWASHER
12	F-1009-01	4	1/4" FLAT WASHER	29	P-11383	1	DECAL, OIL
13	F-1158	4	1/4" LOCK NUT				
14	H-2282	5	HOSE CLAMP				
15	F-1019-01	2	LOCK WASHER				
16	H-2330	3	ADAPTER				
17	H-2331	2	ELBOW				

WIRE HARNESS

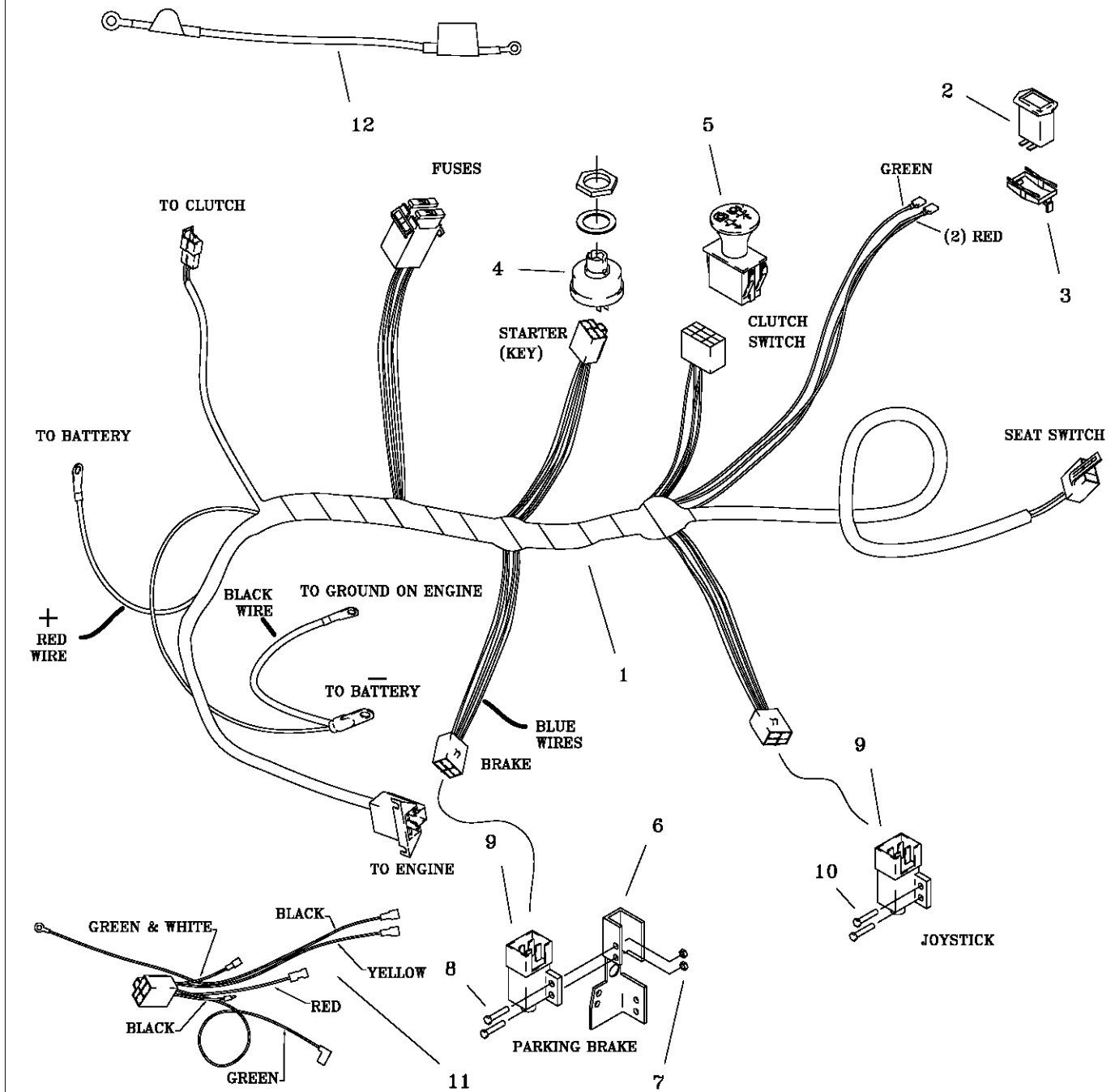

REF NO.	PART NO.	QTY.	DESCRIPTION
1	E-6437	1	WIRE HARNESS, JOYSTICK
2	E-5878	1	HOUR METER
3	E-6369	1	RETAINER CLIP
4	E-5873	1	START SWITCH
5	E-6403	1	CLUTCH SWITCH
6	642-054P	1	BRAKE SWITCH BRACKET
7	F-1448	2	8-32 LOCK NUT
8	F-1022-26	2	8-32 X 5/8 SCREW
9	E-6297	2	PLUNGER SWITCH, JOYSTICK
10	F-1993	2	10-32 X 5/8" THD FORM SCREW
11	E-6417	1	KAWASAKI ADAPTER
12	E-6418	1	WIRE, BATTERY TO STARTER

TWINSTICK WIRE HARNESS

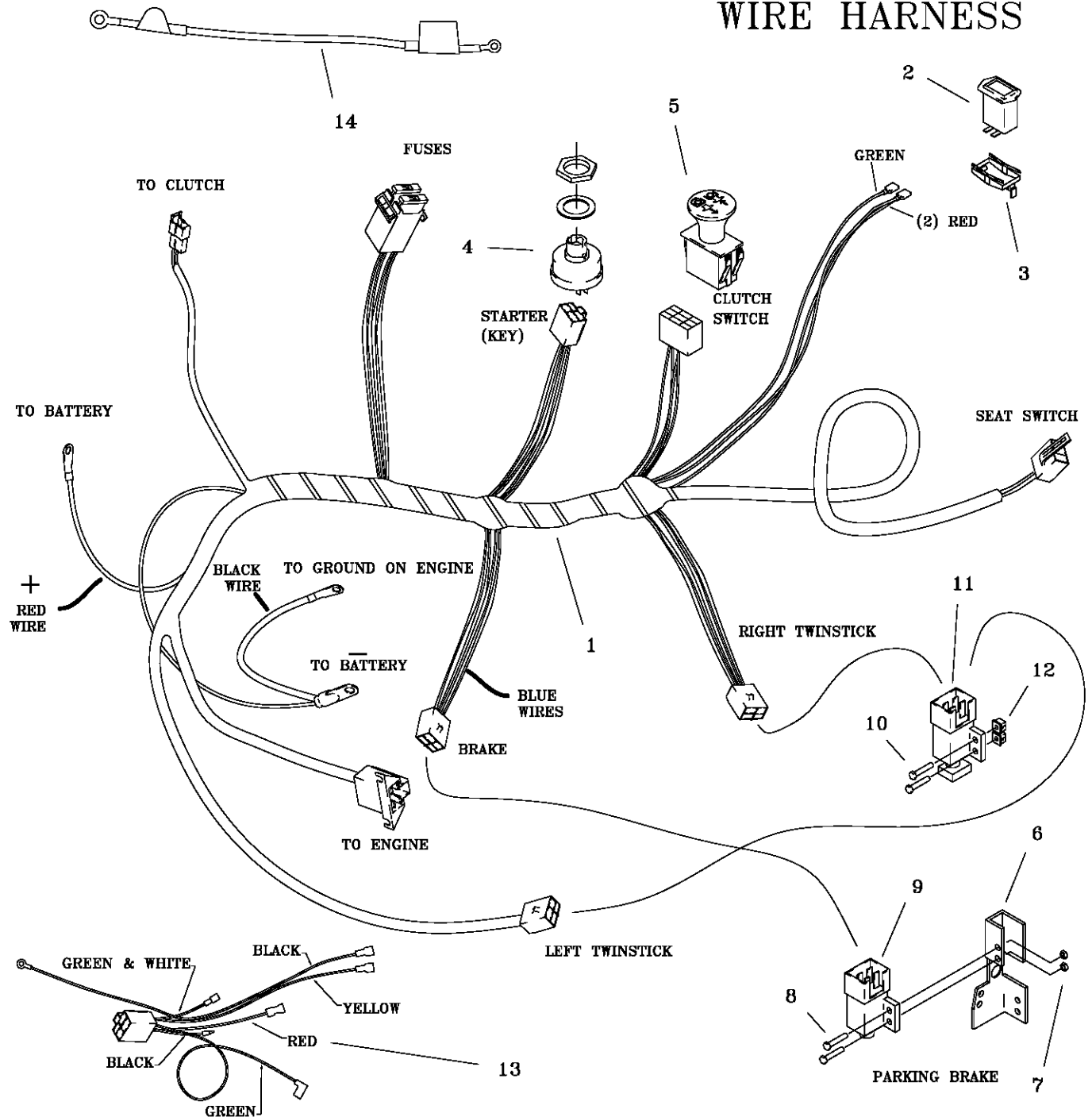

REF NO.	PART NO.	QTY.	DESCRIPTION	REF NO.	PART NO.	QTY.	DESCRIPTION
1	E-6438	1	WIRE HARNESS	12	F-1995	4	GROMMET, #10
2	E-5878	1	HOUR METER	13	E-6417	1	KAWASAKI ADAPTER
3	E-6369	1	RETAINER CLIP	14	E-6418	1	WIRE, BATTERY TO STARTER
4	E-5873	1	START SWITCH				
5	E-6403	1	CLUTCH SWITCH				
6	642-054P	1	BRAKE SWITCH BRACKET				
7	F-1448	2	8-32 LOCK NUT				
8	F-1022-26	2	8-32 X 5/8 SCREW				
9	E-6297	2	PLUNGER SWITCH,				
10	F-1994	4	#10 X 5/8" SCREW,				
11	647-112A	2	SWITCH BLOCK ASS'Y.				