

REPAIR PARTS MANUAL
FOR
COUNTRY
CLIPPER[®]



SR1010



COUNTRY CLIPPER "CHARGER"

ZERO TURN RADIUS MOWER TABLE OF CONTENTS

PAGE.... CONTENTS

SECTION 1 - MOWER DECKS AND RELATED PARTS

- 1-1 DOUBLE IDLER DECK ASSEMBLY
- 1-2 DECK SPINDLE ASSEMBLY
- 1-3 DOUBLE IDLER DRIVE BELT IDLER & RELATED PARTS
- 1-4 LIFT HANDLE ASSEMBLY & RELATED PARTS
- 1-5 LIFT ASSEMBLY & RELATED PARTS
- 1-6 TRANSMISSION IDLERS & RELATED PARTS

SECTION 2 - TRACTOR FRAME AND RELATED PARTS

- 2-7 CASTER WHEEL ASSEMBLY
- 2-8 FRAME SIDES & RELATED PARTS
- 2-9 FENDER ASSEMBLY
- 2-10 SEAT, FOOT DECK & RELATED PARTS
- 2-11 FRONT STEP ASSEMBLY (MODELS WITH SIN 663VI & AFTER)

SECTION 3 - TRACTOR DRIVE AND RELATED PARTS

- 3-12 FUEL TANK ASSEMBLY
- 3-13 JOYSTICK STEERING CONTROL & RELATED PARTS
- 3-14 JOYSTICK STEERING CONTROL & RELATED PARTS (continued) (3/8" LINKAGE)
- 3-15 RIGHT HAND STEERING CONTROL (TWIN STICK)
- 3-16 LEFT HAND STEERING CONTROL (TWIN STICK)
- 3-17 PARKING BRAKE ASSEMBLY & RELATED PARTS
- 3-18 GEAR MOTOR WHEEL ASSEMBLY
- 3-19 MOTOR ASSEMBLY & RELATED PARTS
- 3-20 HIGH PRESSURE LINES & FITTINGS
- 3-21 OIL RETURN LINES & COOLER ASSEMBLY
- 3-22 E-6415 WIRE HARNESS & RELATED PARTS
- 3-23 E-6416 WIRE HARNESS & RELATED PARTS
- 3-24 E-6417 WIRE HARNESS & RELATED PARTS

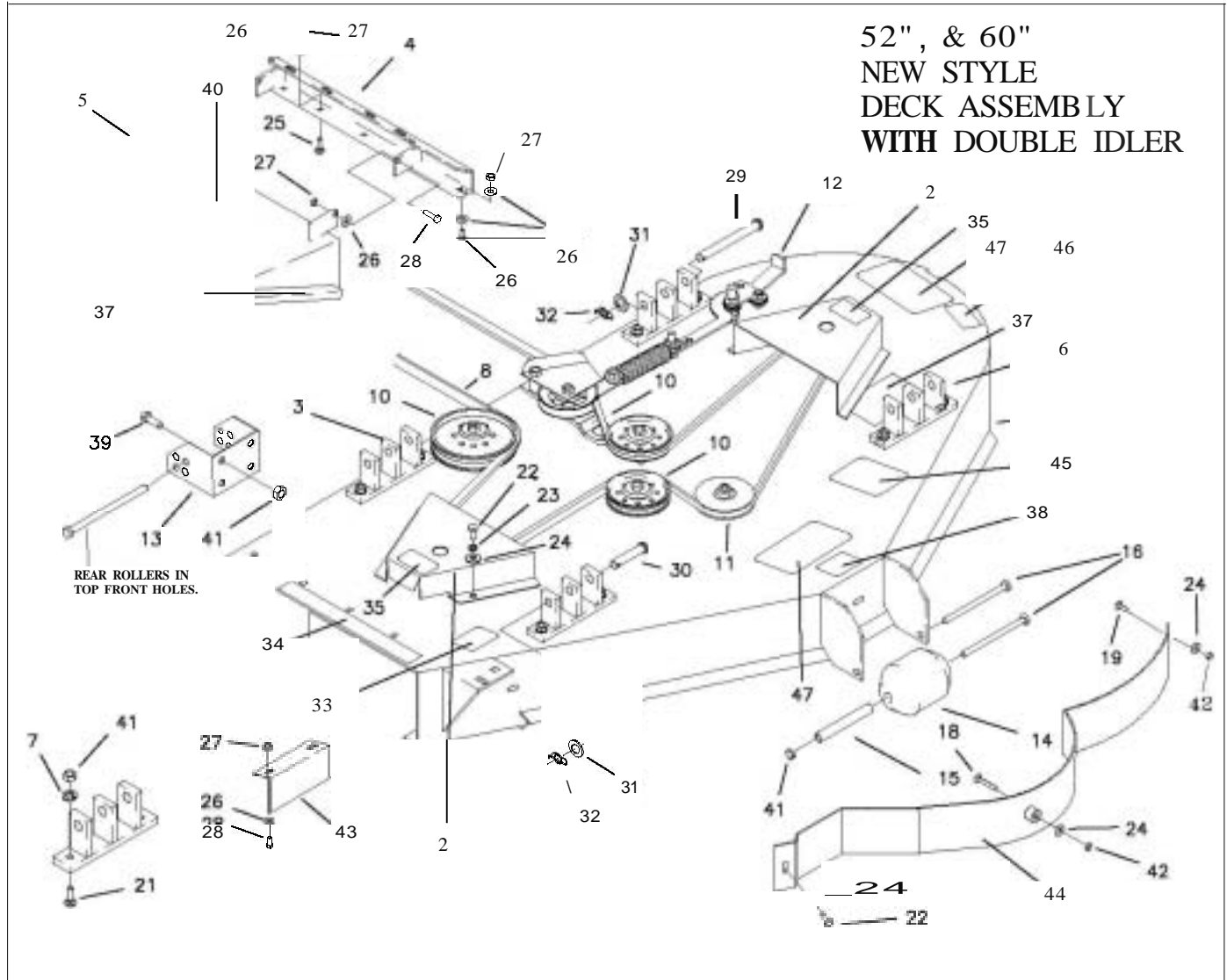

REF NO.	PART NO.	QTY.	DESCRIPTION	REF NO.	PART NO.	QTY.	DESCRIPTION
	668-030A		52" DECK, W/DECALS	24	F-1009-01	7	1/4" FLAT WASHER
	668-031A		60" DECK, W/DECALS	25	F-1671	8	CARRIAGE BOLT 5/16 X 3/4
2	668-024A	2	52" PULLEY COVER W/OECAL	26	F-1009-02	8	5/16" FLAT WASHER
	668-025A	2	60" PULLEY COVER W/DECAL	27	F-1125	11	5/16-18 LOCKNUT
3				28	F-1015-15	5	5/16-18 X 1" GR. 5
4	637-053W	1	OUTLET STIFFENER	29	H-2240	2	PIN. 1/2" X 4-1/2"
5	668-011A	1	DECK CHUTE W/DECAL	30	F-1889	2	PIN, 1/2" X 2-1/2"
6	64J-016W	4	DECK HANGER	31	F-1521	4	1/2" FLAT WASHER
7	F-1019-03	20	3/8 LOCK WASHER	32	H-2239	4	RUE RING 1/2"
8	D-3776-W	1	V-BELT, (KEVLAR) B-180	33	P-10947	1	DECAL, "GREASE SPINDLE"
10			DOUBLE IDLER ASSEMBLY (SEE PG.1-3)	34	P-10122	1	DECAL."MISSING CHUTE"
11		3	SPINDLE ASSEMBLY (SEE PG.1-2)	35	P-1093S	2	DECAL, "ROTATING..."
12			BELT TIGHTING SYSTEM (SEE PG.1-3)	37	P-10941	2	DECAL. "MULTI PERIL"
13	609-182P	2	REAR SCALPER BRACKET	38	P-11413		DECAL, "HOIST POINT"
14	H-1948	5	ROLLER, 3-3/4 DIA. X 4-13/16				
15	609-183P	5	WHEEL BUSHING				
16	F-1741	6	3/8-16 X 6" GR. 5				
17				40	P-10937	1	DECAL. "WARNING"
18	F-1935		CARRIAGE BOLT, 1/4 X 1 1/2	41	F-1005-03	18-26	LOCKNUT, 3/8 STOVER
19	F-1B23		CARRIAGE BOLT, 1/4 X 3/4	42	F-1158	2	LOCKNUT, 1/4-20
20				43	629-230P	1	AIR BAFFLE 52"
21	F-1672	10	CARRIAGE BOLT, 3/8 X 1-1/4		643-042P	1	AIR BAFFLE 60"
22	F-1538	5	1/4-20 X 3/4 GR. 5	44	629-229W	1	DUST BAFFLE WLDT, 52"
23	F-1019-01	4	1/4" LOCKWASHER		643-047W	1	DUST BAFFLE WLDT. 60"
				45	P-119J2	1	DECAL, BELT ROUTING
				46	P-11951	1	DECAL, DECK SIZE 52"
					P-11952	1	DECAL, DECK SIZE 60"
				47	H-19J2	4	SAFETY TREAD

DECK SPINDLE ASSEMBLY

609F-019A
SPINDLE ASSEMBLY

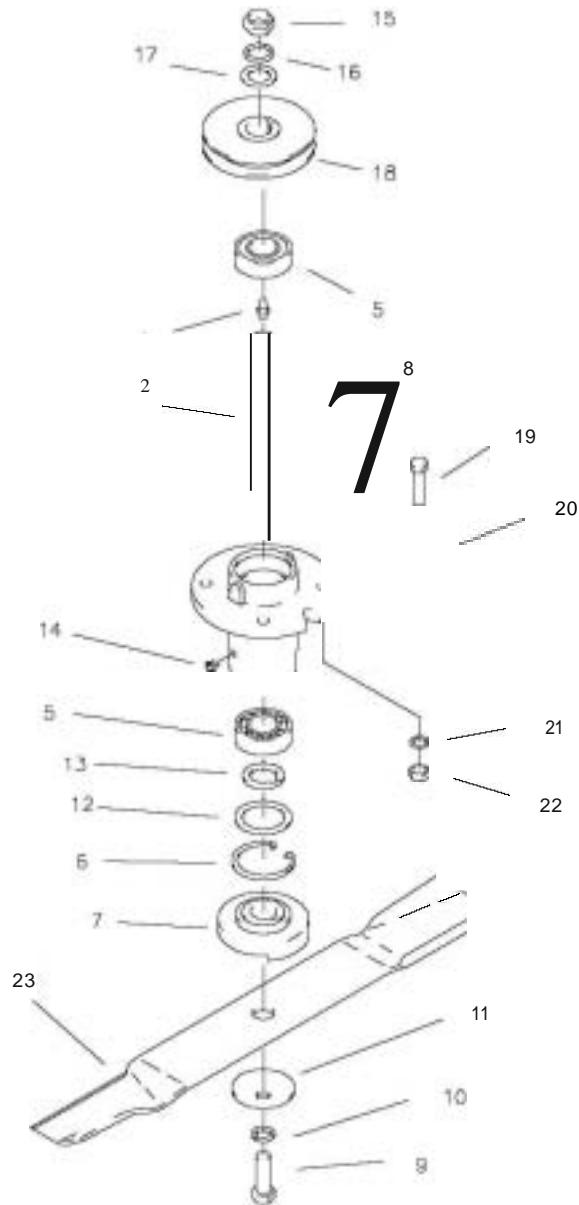

REF NO.	PART NO.	QTY.	DESCRIPTION	REF NO.	PART NO.	QTY.	DESCRIPTION
1	609F-019A		SPINDLE ASSEMBLY	18	668-013P		SPINDLE PULLEY, 52"
2	H-1D56		GREASE FITTING		668-012P		SPINDLE PULLEY, 60"
3	609-162P		SPINDLE SHAFT	19	F-1572	4	3/8-24 X 1 1/2" HHCS GR. 5
4			-----	2D	609-034P	4	SPINDLE SPACER REINFORCEMENT
5	D-3058	2	BEARING, #6205-2RS	21	F-1019-03	4	3/8" LOCK WASHER
6	H-1893	1	SNAP RING INT. 52MM	22	F-1573	4	3/8-24 LOCKNUT, M-F
7	609-152P	1	BLADE SPACER	23	H-2246		BLADE, HIGH L, 1B 3/8" CUT 52"
8	D-1004-02	2	KEY. WOODRUF, 1/4 X 3/4		H-1708		BLADE, HIGH L, 21" CUT 60"
9	F-1526	1	1/2-13 X 1 1/2" HHCS GR. 5				OPTIONAL BLADES
10	F-1464	1	1/2" LOCK WASHER		H-2387		BLADE. LOW L, 18 3/8" CUT, 52"
11	F-1507	1	WASHER, 1/2" CUPPED		H-1667		BLADE. LOW L, 21" CUT, 60"
12	609-151P	1	WASHER, SEAL				
13	609-0np	1	ARBOR SPACER		H-2251		BLADE, GATOR, 18 3/8" CUT 52"
14	H-2D66	1	GREASE VENT 5 LBS.		H-2122		BLADE, GATOR, 21" CUT 60"
15	F-1461	1	3/4-16 NUT, HEX JAM				
16	F-1463	1	3/4" LOCK WASHER				
17	F-1510	1	3/4" WASHER, FLAT sm.				

DOUBLE IDLER DRIVE BELT IDLER & RELATED PARTS

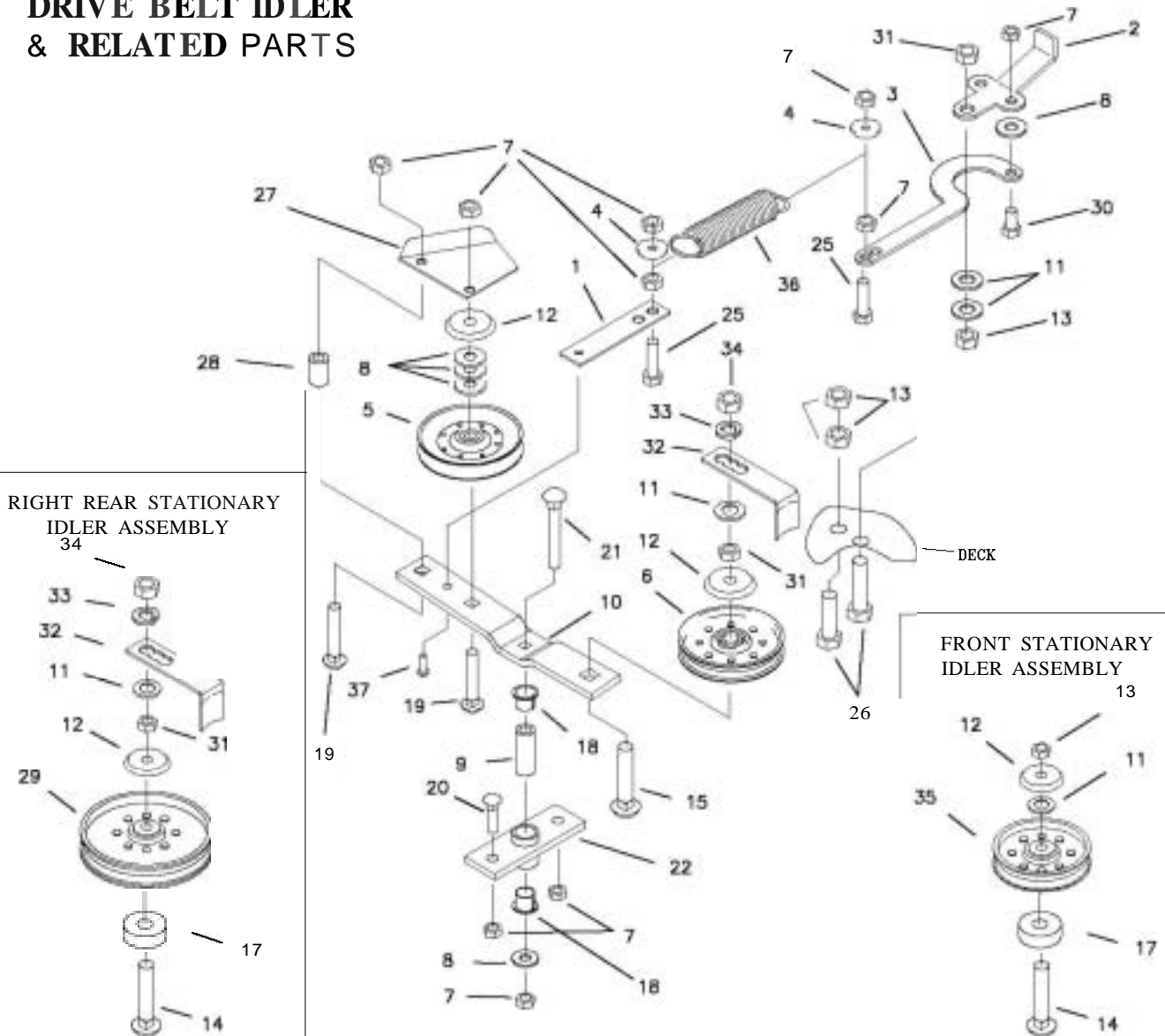

REF NO.	PART NO.	QTY.	DESCRIPTION
	660-081 P	1	EXTENSION FOR SPRING
2	660-030P	1	HANDLE, BELT TIGHTENER
3	660-031 P	1	ARM, BELT TIGHTENER
4	609-034P	2	SPINDLE SPACER REINFORCEMENT
5	0-3758	1	"V" IDLER PULLEY
6	0-3338	1	IDLER PULLEY
7	F-1DD5-03	14	3/8 LOCK NUT
a	F-1009-03	5	3/8 FLAT WASHER
9	659-0a5P	1	MOUNTING PIN
10	660-036P	1	IDLER ARM
11	F-1521	5	1/2" FLAT WASHER
12	620-201 P	4	BEARING CAP
13	F-1005-05	6	1/2" LOCK NUT
14	F-2047	3	1/2-13 X 3' CARRIAGE BOLT
15	F-1822	1	1/2-13 X 2 1/4" CARRIAGE BOLT
16	661-015P	1	SHACKLE
17	660-082P	2	3/8" THICK SPACER
18	0-3730	2	BUSHING, TEFLON COATED
19	F-1976	2	3/8-16 X 1-3/4" CARRIAGE BOLT
20	F-1672	2	3/8-16 X 1-1/4" CARRIAGE BOLT
21	F-1865	1	3/8-16 X 2-1/2" CARRIAGE BOLT

REF NO.	PART NO.	QTY.	DESCRIPTION
22	660-034W	1	MOUNT, DOUBLE IDLER
23	660-038P	3	3/8" THICK SPACER
24	F-1307	1	3/8-16 X 1 1/4" GR. 5
25	F-1394	3	3/8-16 X 1" GR. 5
26	F-1526	4	1/2-13 X 1-1/2" GR. 5
27	668-029P	1	BELT GUARD
28	668-021 P	1	SPACER, BELT GUARD
29	0-3815	1	6" IDLER PULLEY
30	F-1558	1	3/8-16 X 7/8 GR. 5
31	F-1966	4	1/2" THIN NYLOC NUT
32	660-06DP	2	BELT KEEPER
33	F-1464	2	1/2" LOCK WASHER
34	F-14S9	2	1/2" THIN NUT
35	0-3774		5" IDLER PULLEY
36	H-2092		SPRING
37	F-1733		DRIVE STUD

LIFT HANDLE ASSEMBLY & RELATED PARTS

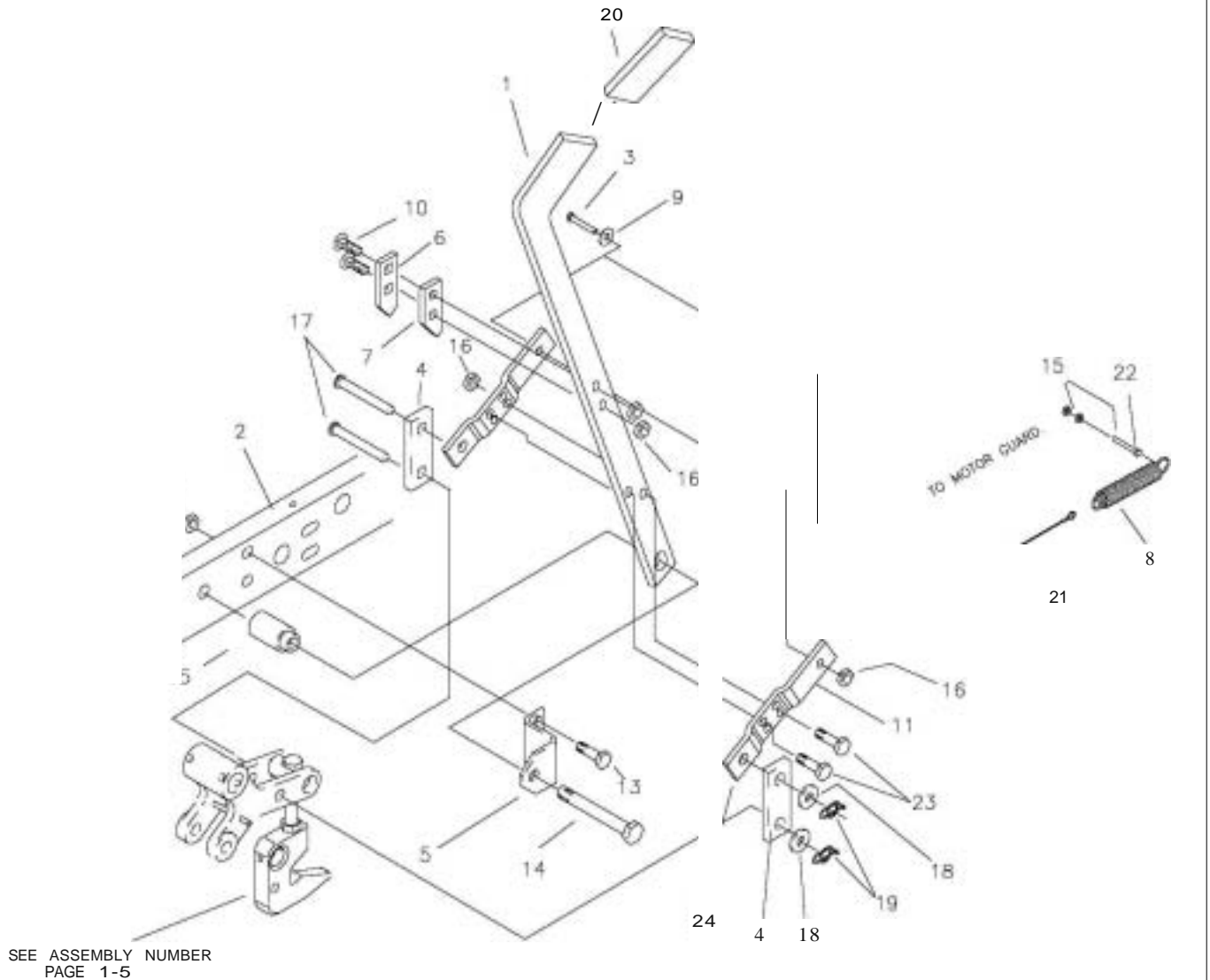

REF NO.	PART NO.	QTY.	DESCRIPTION	REF NO.	PART NO.	QTY.	DESCRIPTION
1	659-060P	1	LIFT HANDLE	15	642-095P	1	HANDLE PIVOT PIN
2	659-D22W	1	FRAME WELDMENT, LH.	16	F-1DD5-03	5	NUT, 3/6-16 LOCKNUT (STOVER)
3	F-1073	1	3/6-16 X 2" GR 5	17	F-1669	2	CLEVIS PIN, 1/2 X 2 5/6"
4	642-061 P	2	HANDLE LINK	16	F-1521	2	1/2" FLAT WASHER
5	642-041 P	1	HANDLE PIVOT BRACKET	19	H-2239	2	RUE RING, 1/2"
6	642-127P	1	TOP PEG LATCH PLATE	20	H-2324	1	VINYL GRIP, 3/6 X 1 1/2"
7	642-126P	1	TOP PEG SPACER PLATE	21	H-2460	1	CABLE
8	H-1610	1	SPRING, 1 1/2" 00. X 6"	22	F-1293	2	1/2-13 X 1 1/2" GR. 5
9	F-1009-03	1	FLAT WASHER, 3/6"	23	F-1307	2	1/2-13 X 1 1/4" GR. 5
10	F-1672	2	CARRIAGE BOLT, 3/6-16 X 1 1/4"	24	642-060P	2	SPRING ANCHOR PLATE
11	659-049P	2	SPRING ANCHOR PLATE				
12	F-1005-05	1	NUT, 1/2-13 LOCKNUT				
13	F-1556	2	3/6-16 X 7/6" GR. 5				
14	F-1439	1	1/2-13 X 3" GR. 5				

LIFT ASSEMBLY & RELATED PARTS

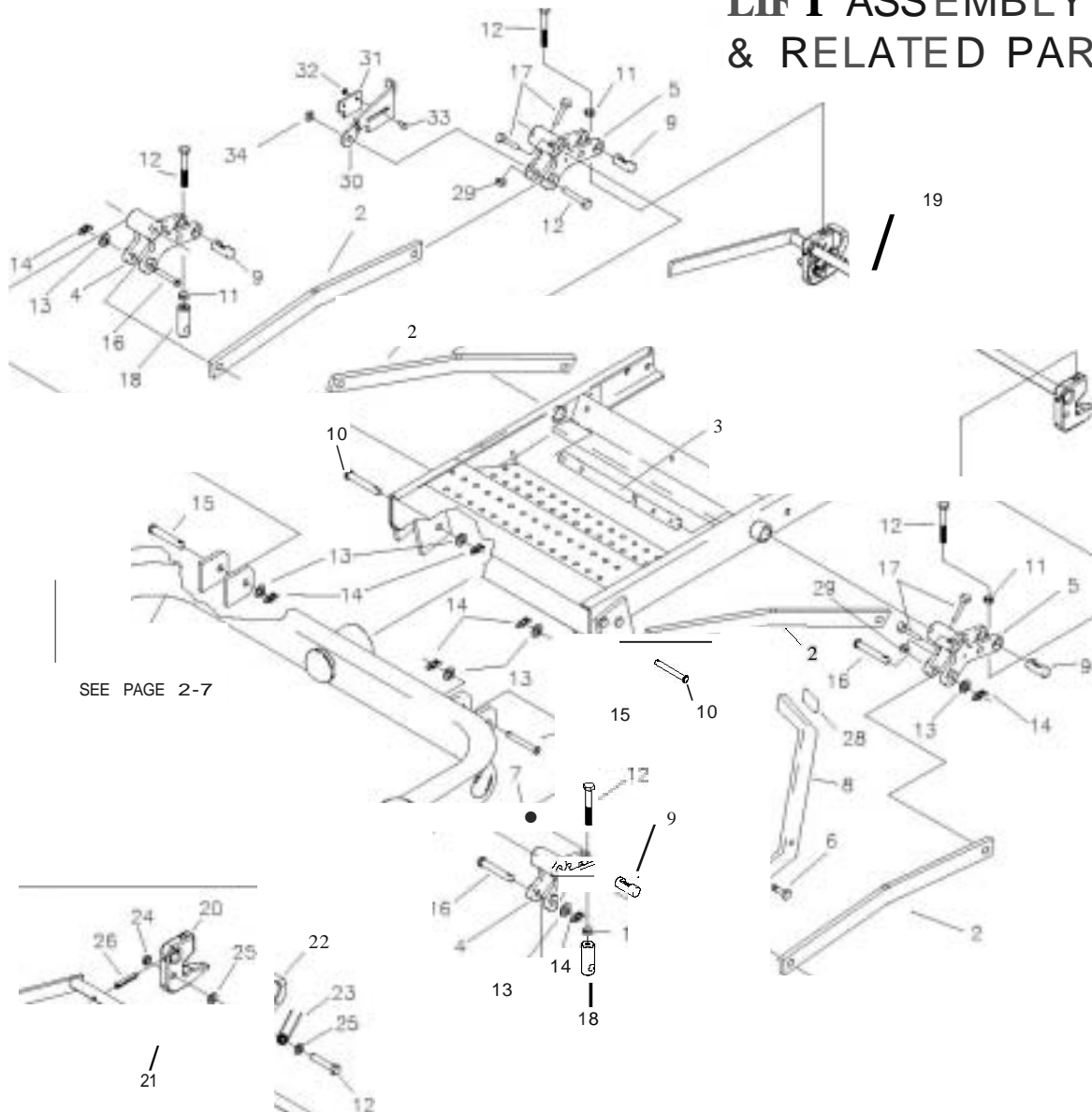

659-171A RELEASE HANDLE ASSEMBLY

REF NO.	PART NO.	QTY.	DESCRIPTION	REF NO.	PART NO.	QTY.	DESCRIPTION
1	642-063P	2	DRAG BAR TAB	18	642-175P	2	ADJUSTABLE HANGER END
2	659-155P	4	DRAG LINK BAR	19	659-171A	1	RELEASE HANDLE ASSEMBLY
3	620-051 P	1	LIFT BAR	20	659-140P	2	DECK HOOK
4	642-081 P	2	LIFT SLEEVE. FRONT	21	6S9-H8W		RELEASE HANDLE WELDMENT
5	642-0B2P	2	Lin SLEEVE. REAR	22	659-145P		HOOK KEEPER
6	F-1879	1	5/16-18 X 1 1/4" GR.5	23	H-2547		SPRING. TORSION
7	F-1125	1	5/16-18 STOVER NUT	24	F-1005-03		NUT. 3/8-16. STOVER
8	659-056P	1	DECK LIFT PEDAL	25	F-1009-OJ	2	WASHER, FLAT, 3/8"
9	642-177P	4	HANGER PIN	26	F-2009	2	SPIROL ROLL PIN 1/4 X 1-1/2
10	F-1896	2	CLEVIS PIN, 1/2 X 1 3/4"	27	F-1073	1	CAPSCREW, 3/8-16 X 2, GR. S
11	F-1489	4	NUT. 1/2" JAM	28	H-2401	1	TREAD PAD
12	F-1936	6	1/2-13 X 3 1/2, 2" THREAD	29	F-2041	4	NUT. 5/16-24 CENTER LOCK
13	F-1521	7	WASHER, 1/2 NARROW	30	6S9-146P	1	LATCH PLATE
14	H-2239	7	RUE RING, 1/2"	31	6S9-170P	1	PLATE, CATCH
15	F-1890	2	CLEVIS PIN, 1/2 X 3 1/2"	32	F-1158	2	NUT. 1/4" STOVER
16	F-1898	3	CLEVIS PIN, 1/2 X 2 3/4"	33	F-1823	2	CARRIAGE BOLT, 1/4-20 X 3/4"
17	F-2039	4	CAPSCREW, 5/16-24 X 2 CR8	34	F-1005-05	1	1/2" STOVER NUT

TRANSMISSION IDLERS & RELATED PARTS

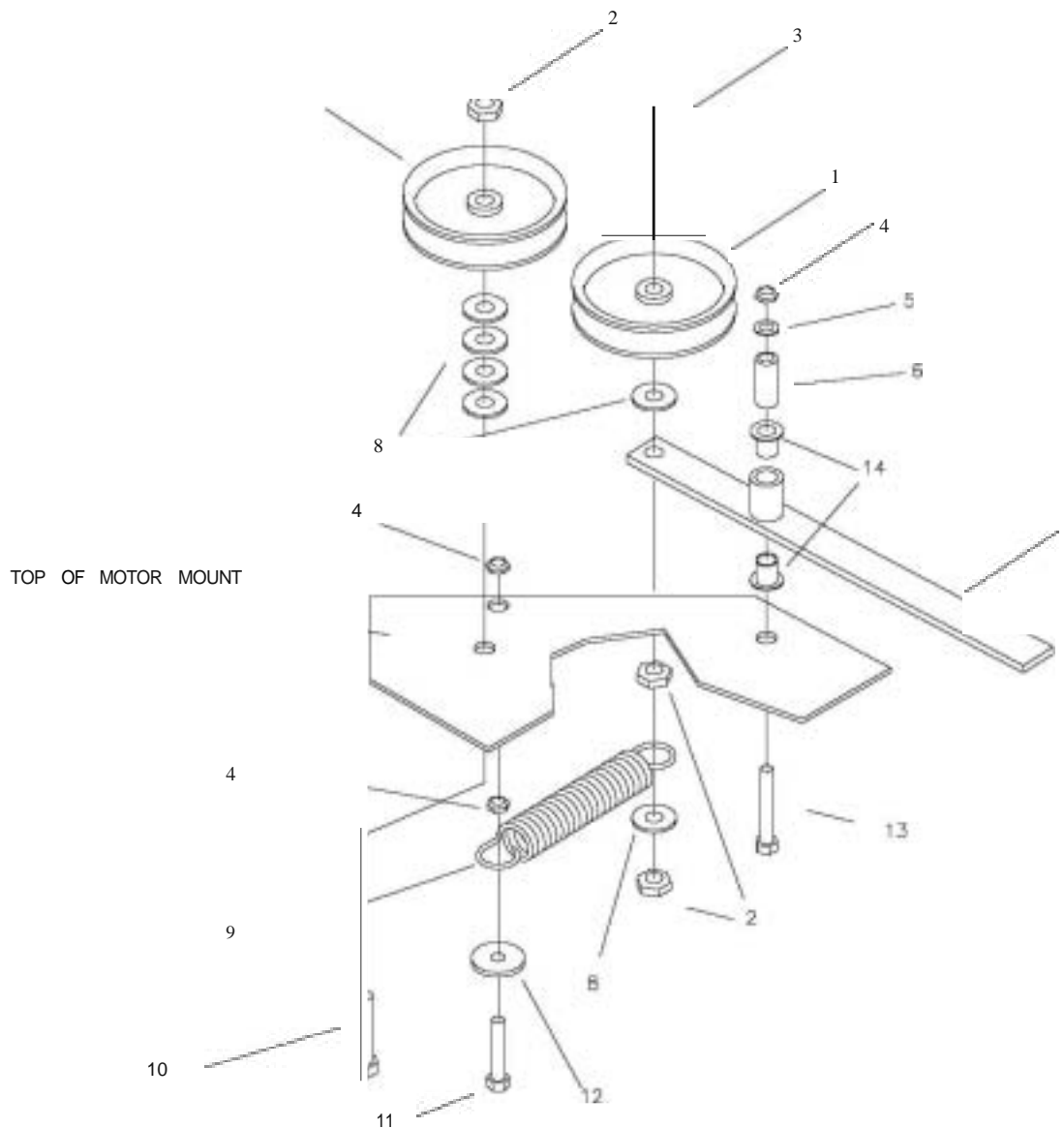

REF NO.	PART NO.	QTY.	DESCRIPTION
1	0-3338	2	4" FLAT IDLER PULLEY
2	F-1005-05	3	1/2-13 STOVER NUT
3	F-1668	1	1/2-13 X 2 3/4 BOLT GR. 5
4	F-1005-03	3	3/8-16 STOVER NUT
5	F-1009-03	1	3/8" FLAT WASHER
6	659-085P	1	MOUNTING PIN
7	663-017W	1	HYDRO IDLER ARM
8	F-1009-05	6	1/2" FLAT WASHER
9	H-2092	1	1 1/4 X 5" SPRING
10	H-1664	1	1/2-13 X 2 1/4" BOLT GR. 5
11	F-1073	1	3/8-16 X 2" BOLT GR. 5
12	609-034P	1	SPACER
13	F-1015-30	1	3/8-16 X 2 1/2" BOLT GR. 5
14	0-3730	2	BUSHING. 5/8" BORE

FRAME SIDES & RELATED PARTS

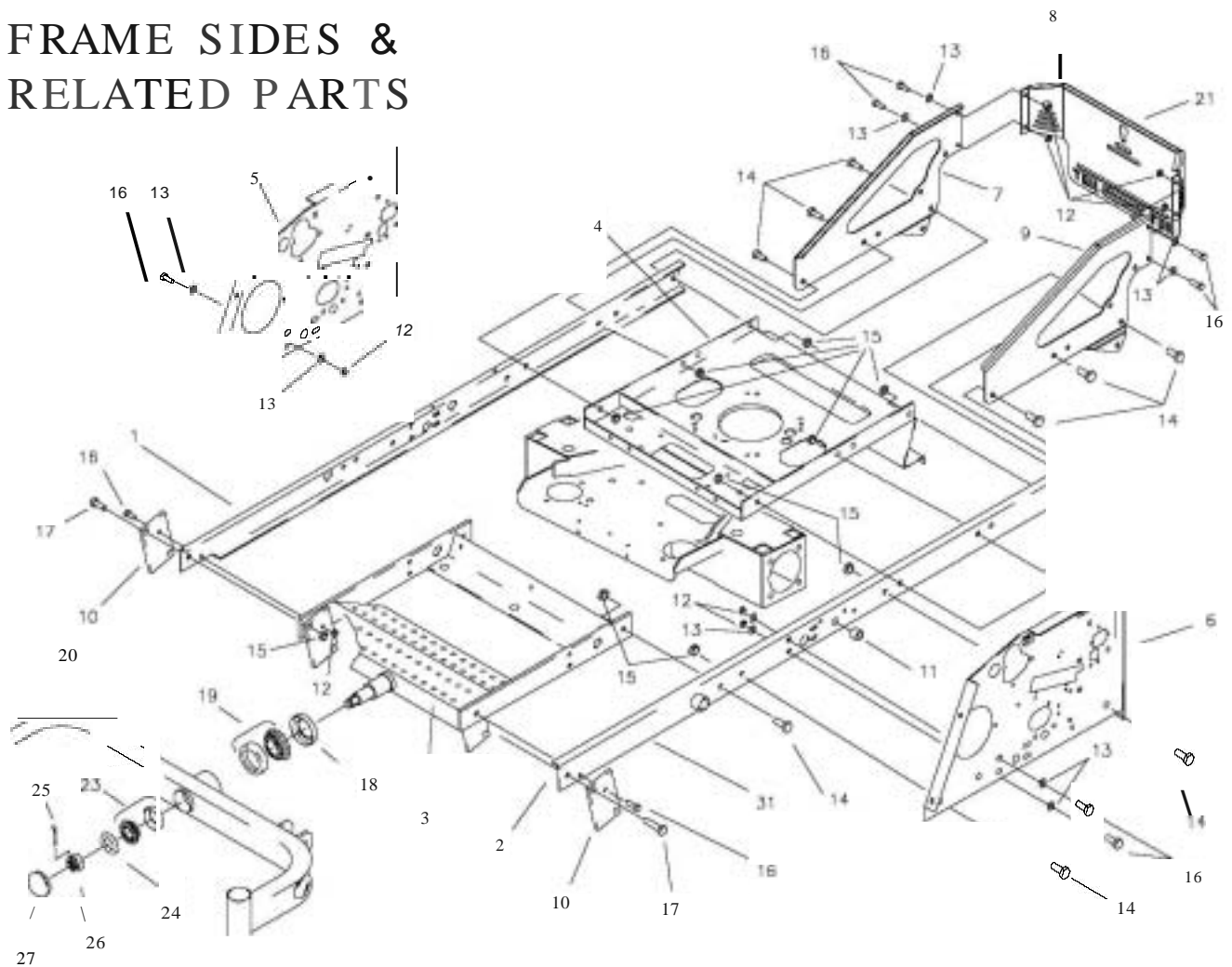

REF NO.	PART NO.	QTY.	DESCRIPTION	REF NO.	PART NO.	QTY.	DESCRIPTION
1	659-021W	1	FRAME SIDE RH.	15	F-1005-05	16	1/2-13 LOCK NUT
2	659-022W	1	FRAME SIDE LH.	16	F-1558	10	3/8-15 X 7/8" GR.5
3	663-029W	1	AXLE MOUNTING WLDT.	17	F-1293	2	1/2-13 X 2", GR.5
4	663-07QW	1	MOTOR MOUNT WLDT.	18	0-3647	1	FRONT PIVOT SEAL
5	659-011 P	1	SIDE PANEL RH.	19	0-3646	1	FRONT PIVOT TAPARED ROLLER BRG.
6	659-012P	1	SIDE PANEL LH.	20	SEE PAGE 2-7	1	FRONT AXLE WELDMENT
7	659-133P	1	RH ENGINE SIDE PANEL	21	P-12097	1	COLORLED DECAL, "COUNTRY CLIPPER"
8	647-123A	1	REAR PANEL GUARD W/ DECAL	22	P-12188	2	DECAL, "SR100S", 07 MOWER
9	659-134P	1	LH ENGINE SIDE PANEL	23	0-3782	1	TAPARED ROLLER BRG.
10	642-063P	2	DRAG BAR TAB	24	606-303P	1	1" WASHER
11	0-3730	2	BUSHING, 5/8 BORE(JOYSTICK)	25	F-1728	1	3/16 X 2" conER PIN
12	F-1005-03	10	3/8-16 STOVER NUT	26	F-1724	1	1-14 SLOnED NUT
13	F-1009-03	16	3/8 FLAT WASHER	27	H-1924	1	GREASE CAP
14	F-1759	12	1 2-13 X 1" GR.5				

FENDER ASSEMBLY

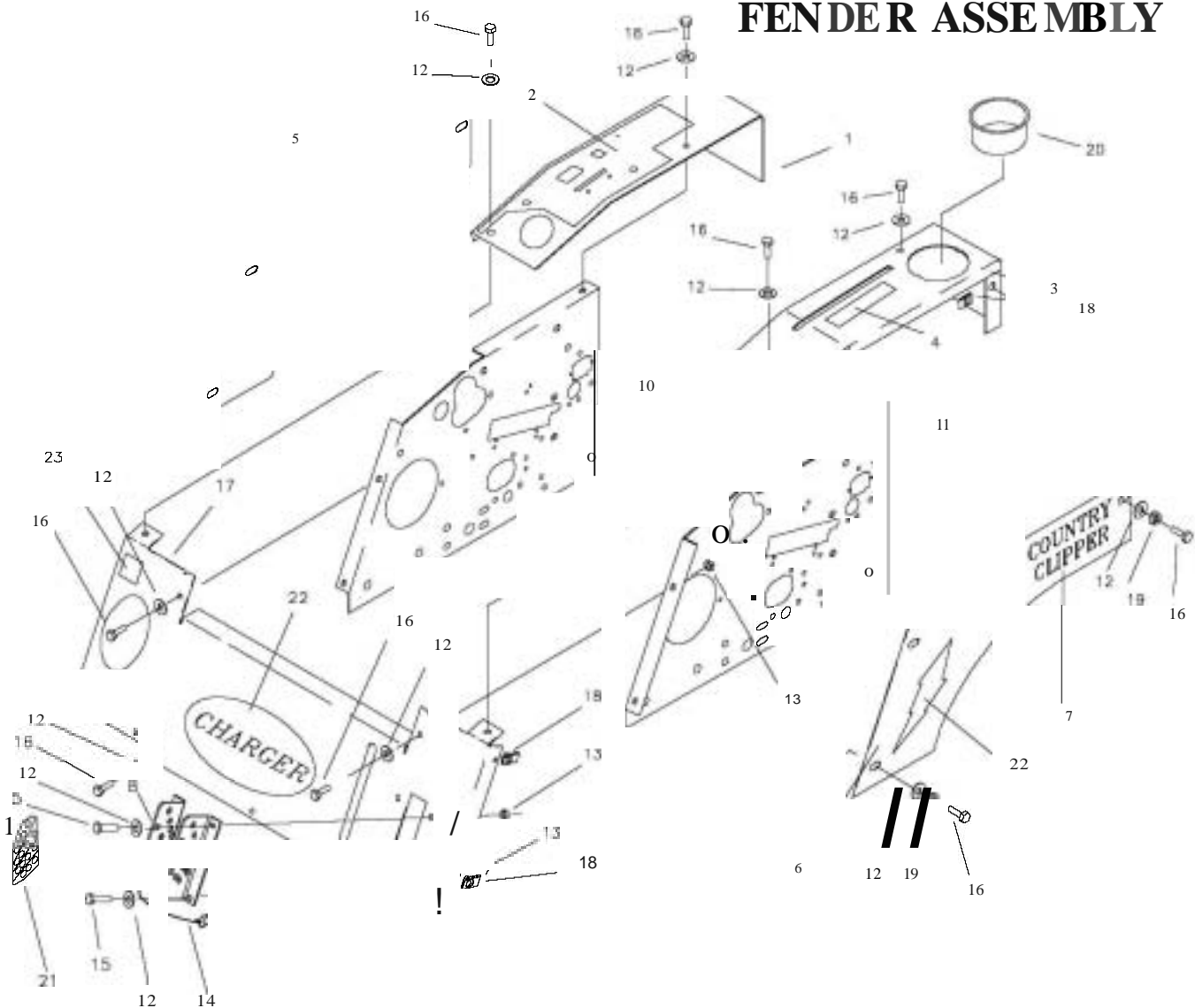

REF NO.	PART NO.	QTY.	DESCRIPTION	REF NO.	PART NO.	QTY.	DESCRIPTION
	663-060A	1	FENDER CAP RH W/OECAL	13	F-1125	8	5/16-18 LOCK NUT
	663-061A	1	FENDER CAP, TWIN STK. RH W/OECAL	14	F-1807	1	1/2" X 2.4 CLEVIS PIN WSASH
2	P-11626	1	DECAL, "CONTROL PANEL"	15	F-1879	4	5/16-18 X 1 1/4" GR. 5
3	663-041A	1	FENDER CAP LH. W/OECAL	16	F-1015-15	20	5/16-18 X 1" GR.5
	663-042A	1	FENDER CAP, TWIN STK. LH. W/OECAL	17	663-043A	1	FRONT PANEL W/OECALS
4	P-11382	1	DECAL, PARK BRAKE	18	F-1860	8	5/16 U-NUT
5	663-053A	1	FENDER SKIRT RH W/OECALS	19	F-1019-02	8	5/16 LOCK WASHER
6	663-054A	1	FENDER SKIRT LH W/OECALS	20	644-028P	1	CUP HOLDER
7	P-12098	2	DECAL, COUNTRY CLIPPER, SMALL	21	P-12034	1	DECAL, "CUT HEIGHT"
8	647-097A	1	LATCH PLATE RH W/OECAL	22	P-11832	1	DECAL, "CHARGER"
9	647-095P	1	LATCH PLATE LH.	23	P-10939	1	DECAL, "CAUTION"
10	659-011 P	1	SIDE PANEL RH.				
11	659-012P	1	SIDE PANEL LH.				
12	F-1009-02	20	5/16 FLAT WASHER				

SEAT, FOOTDECK & RELATED PARTS

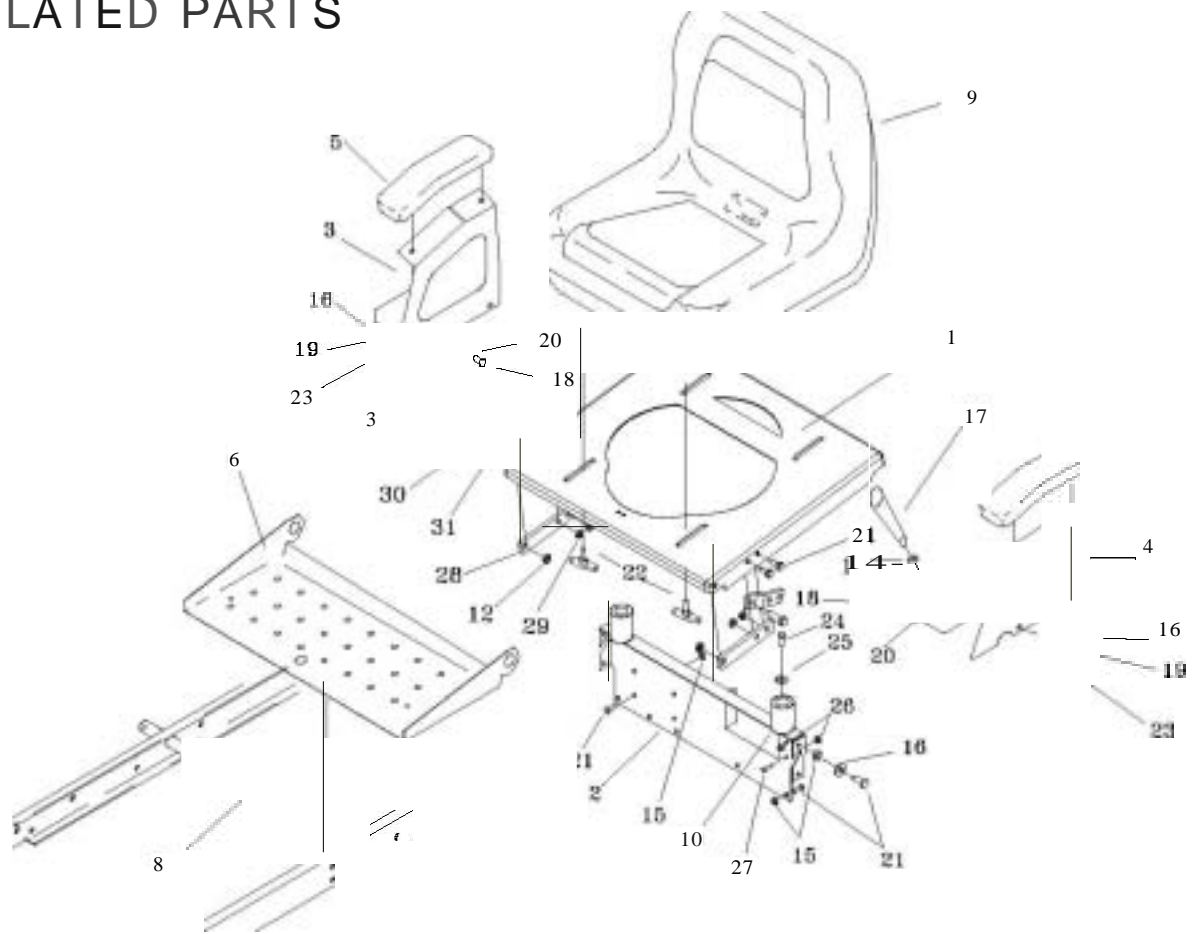

REF NO.	PART NO.	QTY.	DESCRIPTION	REF NO.	PART NO.	QTY.	DESCRIPTION
1	6S9-00SP	1	SEAT MOUNTING BASE	17	H-2317	1	TAPERED HANDLE (JOYSTICK)
2	663-010P	1	REAR SEAT BRACE	18	F-1015-23	4	3/8-16 X 3/4" GR. 5
3	659-051 P	1	ARM REST RH. (JOYSTICK)	19	F-1019-02	4	5/16 LOCK WASHER
	636-163P	1	ARM REST. (TWIN STICK)	20	F-1019-03	4	3/8 LOCK WASHER
4	6S9-055W	1	ARM REST LH. (JOYSTICK)	21	F-1546	12	5/16-18 X 3/4" GR. 5
	636-163P	1	ARM REST. (TWIN STICK)	22	659-073A	4	T-HANDLE ASSEMBLY
5	621-143A	2	ARM REST PAD	23	F-1015-15	4	5/16-18 X 1" GR. 5
6	659-D06P	1	FOOT DECK	24	F-1015-09	2	1/4-20 X 2". GR.5
7	-----		-----	25	F-1009-DI	2	1/4" FLAT WASHER
8	620-051 P		LIFT BAR	26	F-IIS8	4	1/4" STOVER NUT
9	H-2586		SEAT	27	F-1539	2	1/4-20 X 1 1/4", GR.S
10	659-192P	2	SPACER	28	659-175P	2	SEAT HINGE TAB
11	F-1015-27	2	3/8-16 X 1 1/2" GR. 5	29	F-1125	4	5/16-18 STOVER NUT
12	F-1005-03	4	3/8-16 LOCK NUT	30	F-1307	2	3/8-16 X 1-1/4 CAPSCREW
13	-----		-----	31	647-086P	2	FLIP SEAT MATING TAB
14	F-1486	1	3/8-16 JAM NUT				
15	F-1005-02	12	5/16-18 LOCK NUT				
16	F-1009-02	8	5/16 FLAT WASHER				

FRONT STEP ASSEMBLY

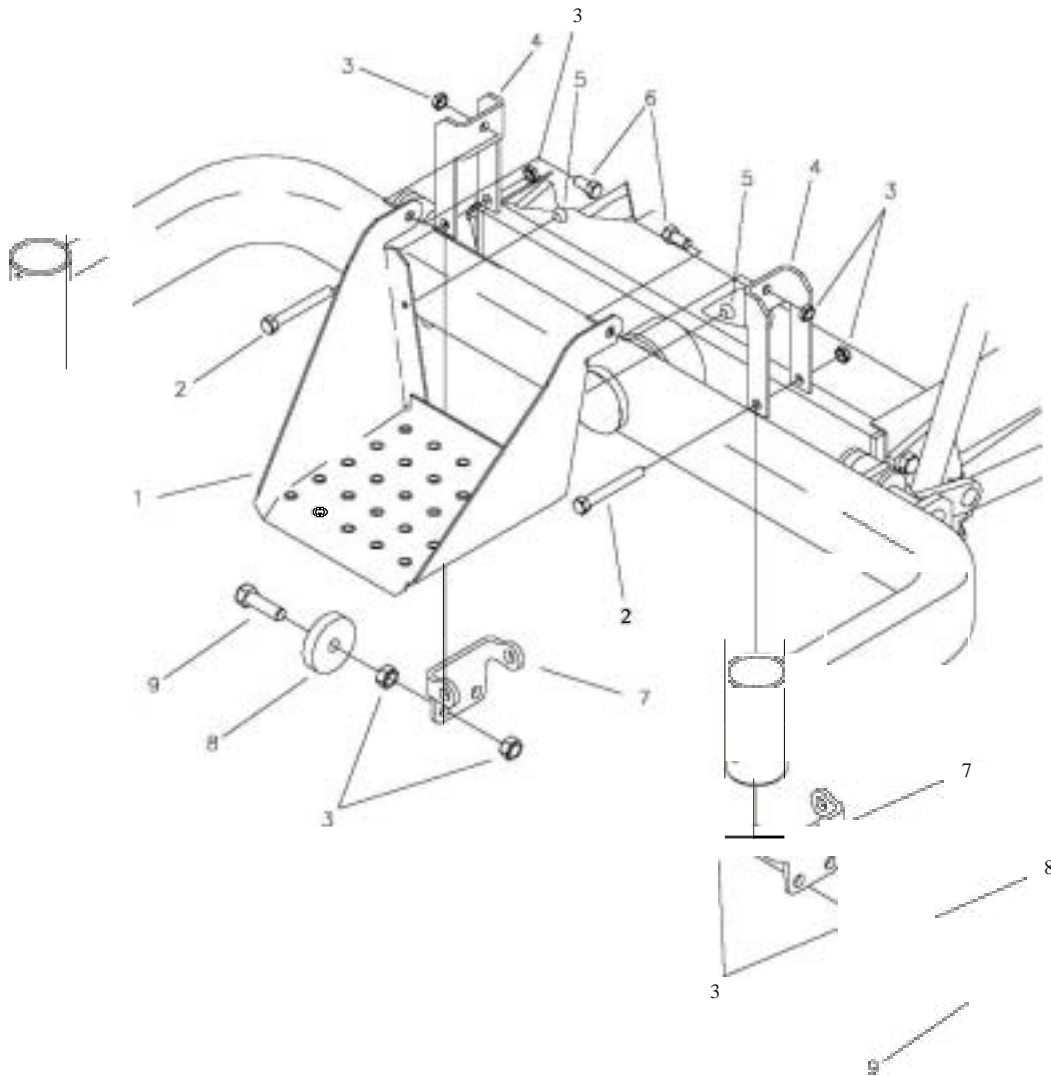

REF NO.	PART NO.	QTY.	DESCRIPTION
1	647-133P	1	FRONT STEP
2	F-1616	2	3/8-16 X 3-1/4" HEX HEAD BOLT
3	F-1005-03	8	3/8-16 LOCK NUT
4	647-134P	2	FRONT STEP YOKE
5	H-2461	2	RUBBER BUMPER BUTTON
6	F-1015-23	2	3/8-16 X 3/4" HEX HEAD BOLT
7	629-636P	2	ROLLER MOUNT
8	642-105P	2	ROLLER
9	F-1307	2	3/8-16, 1-1/4" GR.5 BOLT

FUEL TANK ASSEMBLY

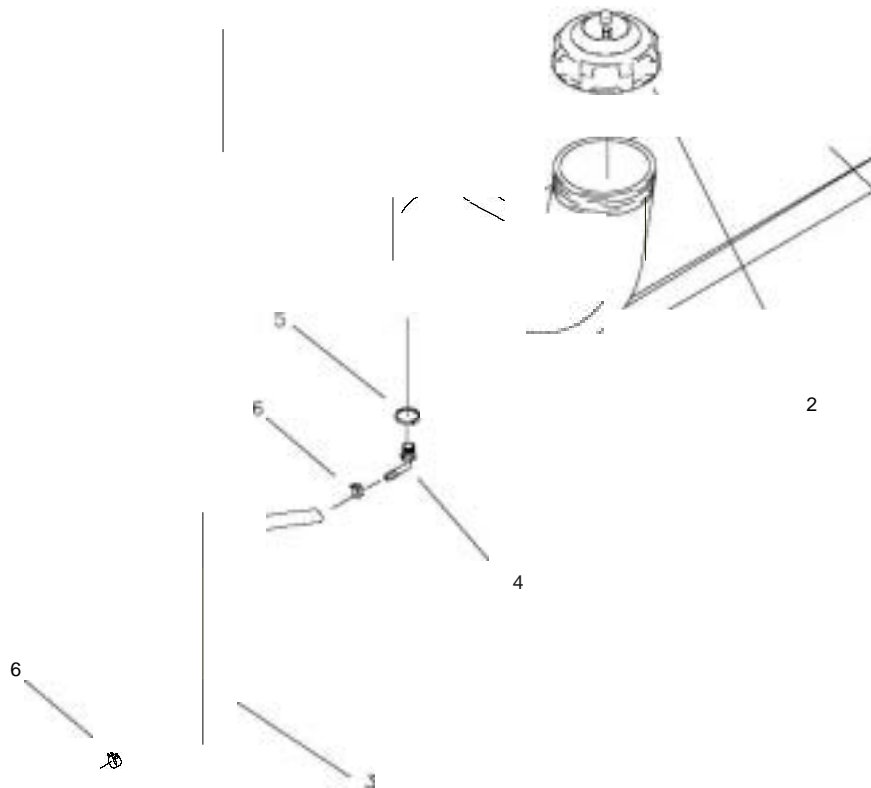

REF NO.	PART NO.	QTY.	DESCRIPTION
1	H-2450	1	8 GALLON TANK
2	H-2232	1	GAS CAP
3	644-034P	1	29 1/2" FUEL LINE
4	H-1646	1	HOSE BARB, 90 OEG.
5	H-1952	1	HOSE CLAMP
6	H-1687	2	HOSE CLAMP. 1/2"

JOYSTICK STEERING CONTROL AND RELATED PARTS

NOTE: ITEMS #2 AND #3 MUST BE REPLACED AT THE SAME TIME FOR MAXIMUM PERFORMANCE.

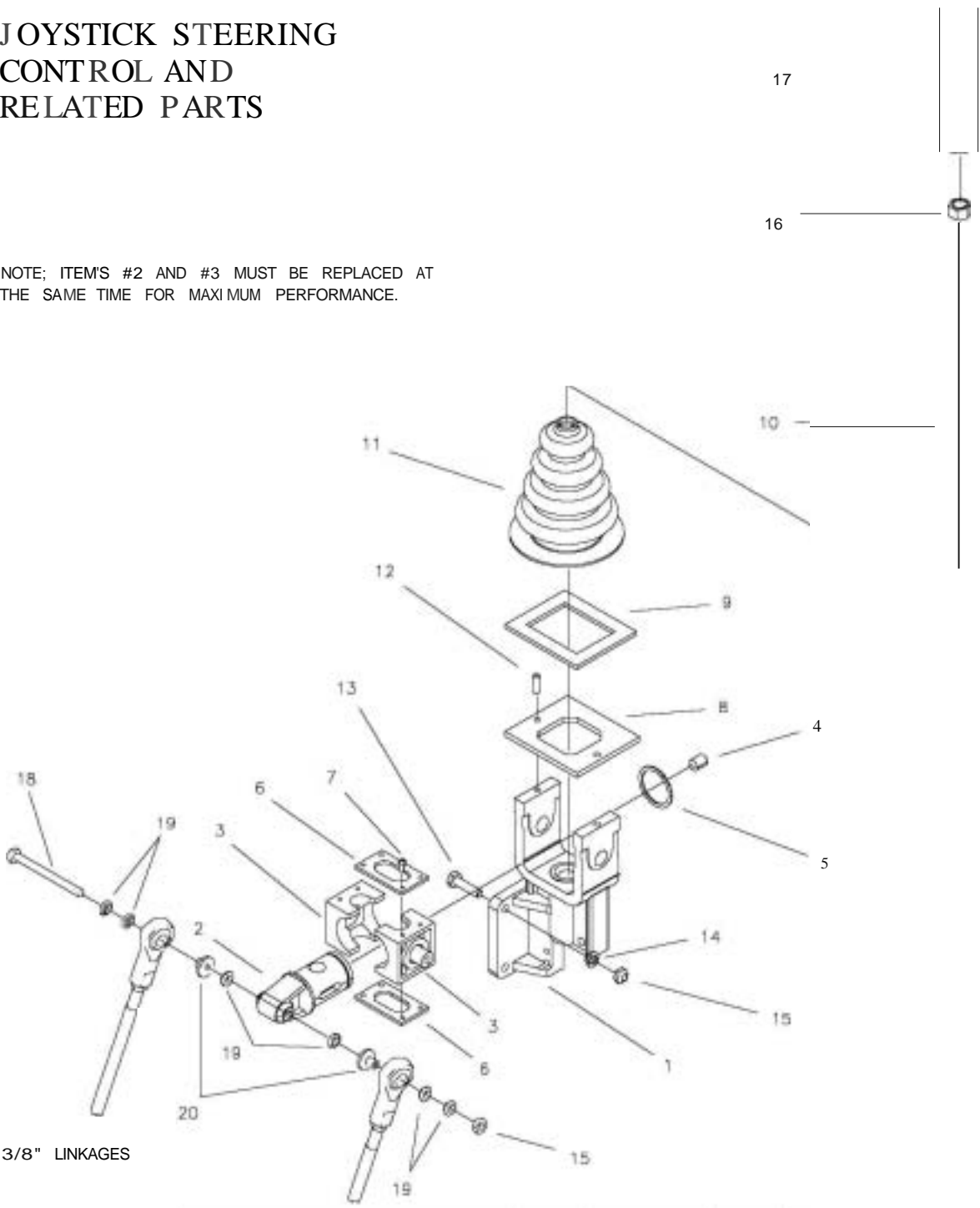

3/8" LINKAGES

REF NO.	PART NO.	QTY.	DESCRIPTION	REF NO.	PART NO.	QTY.	DESCRIPTION
1	647-122A	1	JOYSTICK ASSEMBLY	11	H-1991	1	BOOT. BELLOWS
2	659-144P	1	JOYSTICK YOKE	12	F-1999	2	ROLL PIN, 3/16 X 5/8
3	H-1992	1	PIVOT SHAFT	13	F-1015-05	3	1/4-20 X 1" HHCS GR. 5
4	H-1993	2	PIVOT BLOCK	14	F-1019-01	3	1/4" LOCK WASHER
5	F-1120	1	BALL PLUNGER	15	F-1158	4	1/4-20 LOCK NUT
6	H-1997	1	SNAP RING. SPIRLOCK	16	F-1011-03	1	3/8-16 NUT. JAM
7	619-306P	2	PIVOT BLOCK PLATE	17	H-2317	1	GRIP, HANDLE
8	F-1624	8	#6-32 X 3/8" SCREW SLOT	18	F-1020-01	1	1/2-20 X 3-1/2" GR. 5
9	659-129P	1	JOYSTICK TOP PLATE	19	H-1989	6	BUSHING. BALL JOINT
10	H-1947	1	GASKET, FOAM	20	H-2465	2	1/4" SPACER
	621-140A	1	JOYSTICK SHAFT ASSEMBLY				

RIGHT HAND STEERING CONTROL AND RELATED PARTS

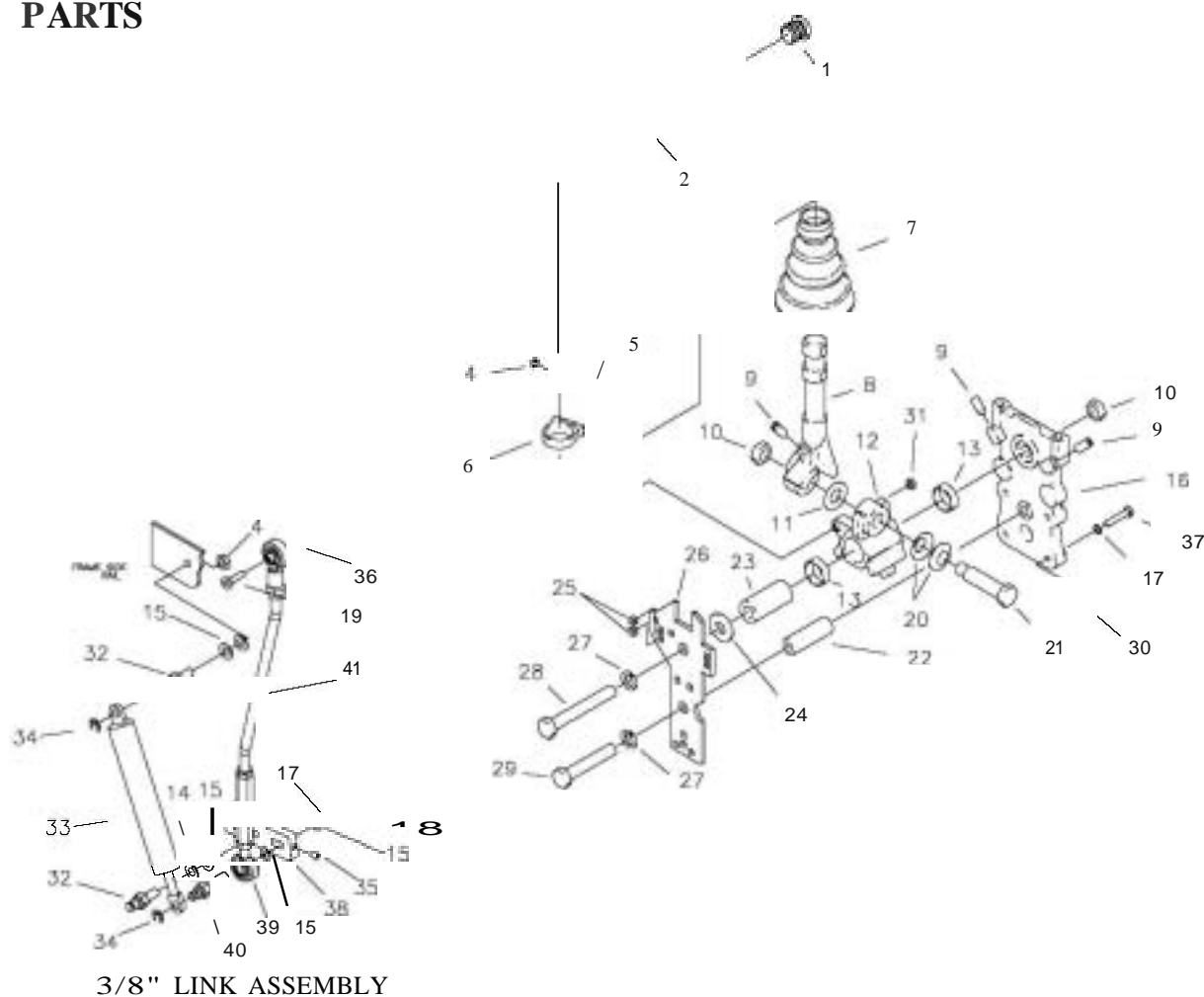

3/8" LINK ASSEMBLY

REF NO.	PART NO.	QTY.	DESCRIPTION	REF NO.	PART NO.	QTY.	DESCRIPTION
1	636-168A	1	RH DUAL LEVER ASSEMBLY	25	F-1995	2	GROMMET. NYLON
2	H-2080	1	END PLUG. 15/16" BLACK	26	636-167P	1	TOP PLATE. DUALEVER
3	H-2D79	1	FOAM GRIP. 17"	27	F-1464	2	1/2" LOCK WASHER
4	642-D04A	1	CONTROL LEVER ASSEMBLY	28	F-1828	1	1/2-13 X 3-1/2" HHCS GR. 5
5	F-1125	3	5/16 LOCK NUT	29	F-1439	1	1/2-13 X 3" HHCS GR. 5
6	F-1015-17	2	5/16-18 X 1-1/2" HHCS GR. 5	30	F-1158	3	1/4-20 LOCK NUT
7	H-2089	1	HOSE CLAMP	31	F-1748	1	1/4-20 THIN NYLOC NUT
8	H-2081	1	BOOT, TAPERED 1" CUFF	32	638-028P	2	DAMPER BOLT, 5/16-18 X 3/4"
9	625-063P	1	LEVER, DUALEVER	33	H-2168	1	STEERING DAMPER
10	F-1842	3	SETSCREW, 5/16-18 X 3/4"	34	F-1610	2	E-RING FOR 1/4" SHAFT
11	F-1489	2	1/2-13 JAM NUT	35	F-1695	1	1/4-20 SETSCREW
12	H-2116	1	WASHER, FIBER	36	H-2465	1	1/4 X 5/16" SHOULDER WASHER
13	638-033P	1	PIVOT BLOCK, DUALEVER	37	F-1539	3	1/4-20 X 1-1/4" HHCS GR. 5
14	0-3622	2	BEARING	38	663-022P	1	SHIFT ARM
15	F-1019-02	1	5/16" LOCK WASHER	39	H-1885	1	BALL JOINT W\1/4-28 THREAD
16	F-1009-02	5	WASHER, FLAT STD. 5/16"	40	663-051 P	1	DAMPNER BOLT, FEMALE
17	638-034P	1	BASE DUALEVER	41	663-050P	1	LINK ROD ASSEMBLY
18	F-1019-01	4	1/4" LOCK WASHER				
19	F-1015-05	1	1/4-20 X 1" HHCS GR. 5				
20	F-1974	1	1/4-20 X 1-1/4" SOCK BOLT				
21	H-2115	2	WASHER, SPRING				
22	625-D70P	1	SHOULDER BOLT. 5/8" 00				
23	625-067P	1	BUSHING. STAND OFF				
24	625-064P	1	BUSHING. PIVOT BLOCK				
	625-072P	1	WASHER. FLAT				

LEFT HAND STEERING CONTROL AND RELATED PARTS

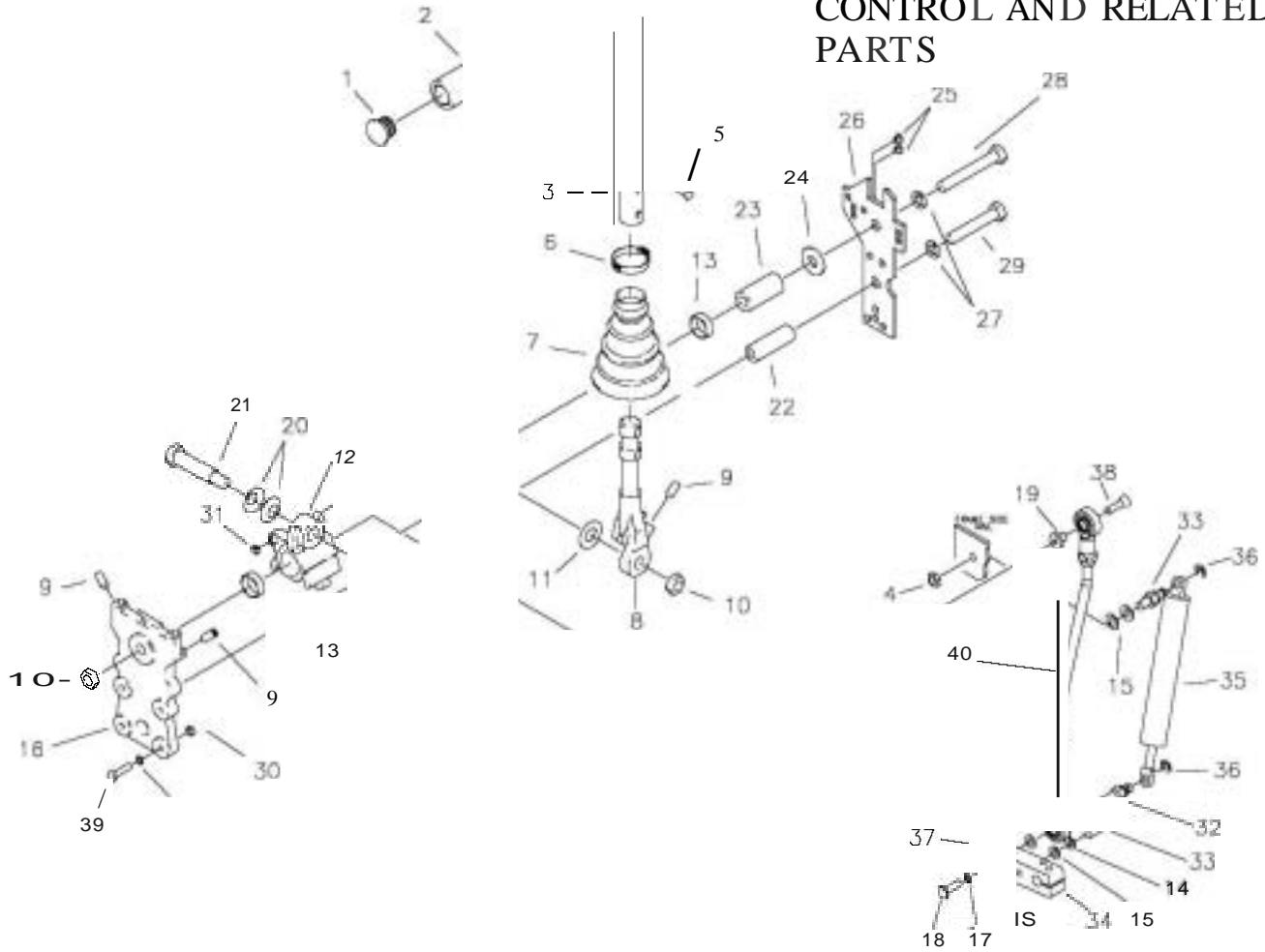

3/8" LINK ASSEMBLY

REF NO.	PART NO.	QTY.	DESCRIPTION	REF NO.	PART NO.	QTY.	DESCRIPTION
	636-169A	1	LH DUAL LEVER ASSEMBLY	26	636-167P	1	TOP PLATE, DUALEVER
1	H-2D80	1	END PLUG, 15/16" BLACK	27	F-1464	2	1/2" LOCK WASHER
2	H-2D79	1	FOAM GRIP, 17"	28	F-1828	1	1/2-13 X 3-1/2" HHCS GR. 5
3	642-D04A	1	CONTROL LEVER ASSEMBLY	29	F-1439	1	1/2-13 X 3' HHCS GR. 5
4	F-1125	3	5/16 LOCK NUT	30	F-1158	5	1/4-20 LOCK NUT
5	F-1015-17	2	5/16-18 X 1-1/2" HHCS GR. 5	31	F-1748	1	1/4-20 THIN NYLOC NUT
6	H-2089	1	HOSE CLAMP	32	663-051 P	1	OAMPNER BOLT, 1/4-20 FEMALE
7	H-2081	1	BOOT, TAPERED 1" CUFF	33	638-028P	2	DAMPER BOLT, 5/16-18 X 3/4"
8	625-063P	1	LEVER, OUALEVER	34	663-022P	1	SHIFT ARM
9	F-1842	3	SETSCREW, 5/16-18 X 3/4"	35	H-2168	1	STEERING DAMPER
10	F-1489	2	1/2-13 JAM NUT	36	F-1610	2	E-RING FOR 1/4" SHAFT
11	H-2116	1	WASHER, FIBER	37	F-1695	1	1/4-20 SETSCREW
12	638-033P	1	PIVOT BLOCK, DUALEVER	38	F-1974	1	1/4-20 XD 3-1/2" BOLT GR 5
13	0-3622	2	BEARING	39	F-1539	3	1/4-20 X 1-1/4" HHCS GR. 5
14	F-1019-02	1	5/16" LOCK WASHER	40	663-050P	1	LINK ROD ASSEMBLY
15	F-1009-02	5	WASHER, FLAT STD. 5/16"				
16	638-034P	1	BASE OUALEVER				
17	F-1019-01	4	1/4" LOCK WASHER				
18	F-1015-05	1	1/4-20 X 1" HHCS GR. 5				
19	H-2465	1	1/4 X 5/16" SHOULDER WASHER				
20	H-2115	2	WASHER, SPRING				
21	625-070P	1	SHOULDER BOLT, 5/8" 00				
22	625-067P	1	BUSHING, STAND OFF				
23	625-D64P	1	BUSHING, PIVOT BLOCK				
24	625-072P	1	WASHER, FLAT				
25	F-1995	2	GROMMET, NYLON				

PARKING BRAKE ASSEMBLY & RELATED PARTS

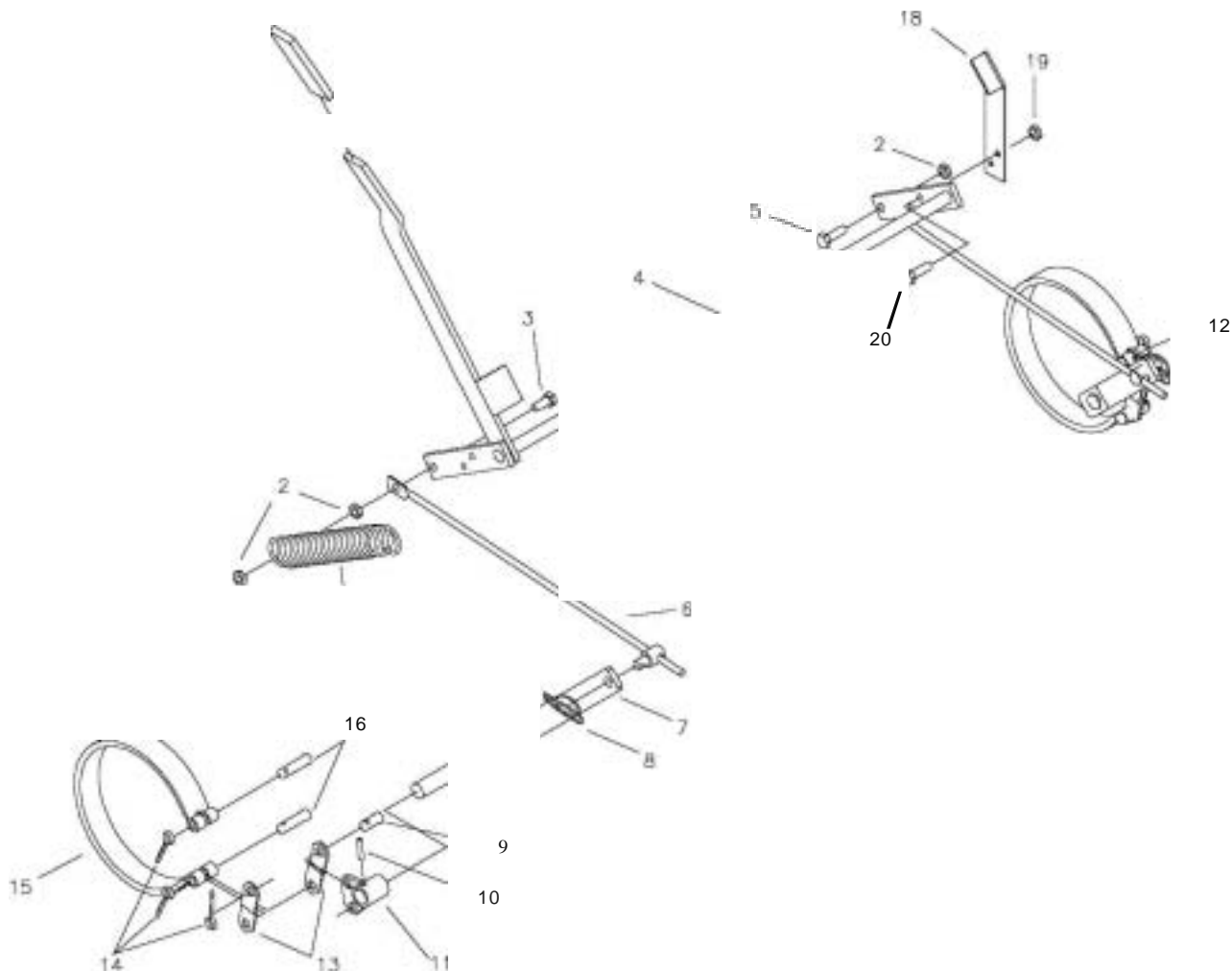

REF NO.	PART NO.	QTY.	DESCRIPTION
1	H-1635	1	3/4 X 4" SPRING
2	F-1125	3	5/16-18 STOVER NUT
3	F-I015-15	1	5/16-18 X 1" BOLT
4	663-024W	1	BRAKE ROD WLOT
5	F-1546	1	5/16-18 X 3/4" BOLT
6	H-2451	2	BRAKE LINK ROD ASSEMBLY
7	647-013W	2	BRAKE ARM WLDT
8	F-1492	2	5/16 X 3/8" RUE RING
9	F-1438	2	3/8 X 3/4" CLEVIS PIN
10	F-1553	2	5/16 X 7/8" ROLL PIN
11	647-029W	1	SHORT BRAKE ARM (LH)
12	647-028W	1	SHORT BRAKE ARM (RH)
13	647-010P	4	BRAKE ANCHOR LINK
14	F-1491	6	1/8 X 1" conER PIN
15	0-3668	2	BRAKE BAND 6" X 1" WDE
16	F-1444	4	3/8 X 1 5/16" CLEVIS PIN
17	H-1926	1	GRIP HANDLE
18	663-062P	1	BRAKE SWITCH STOP
19	F-1158	2	1/4-20 STOVER NUT
20	F-I015-05	2	1 4-20 X 5 8 BOLT

GEAR MOTOR, WHEEL ASSEMBLY

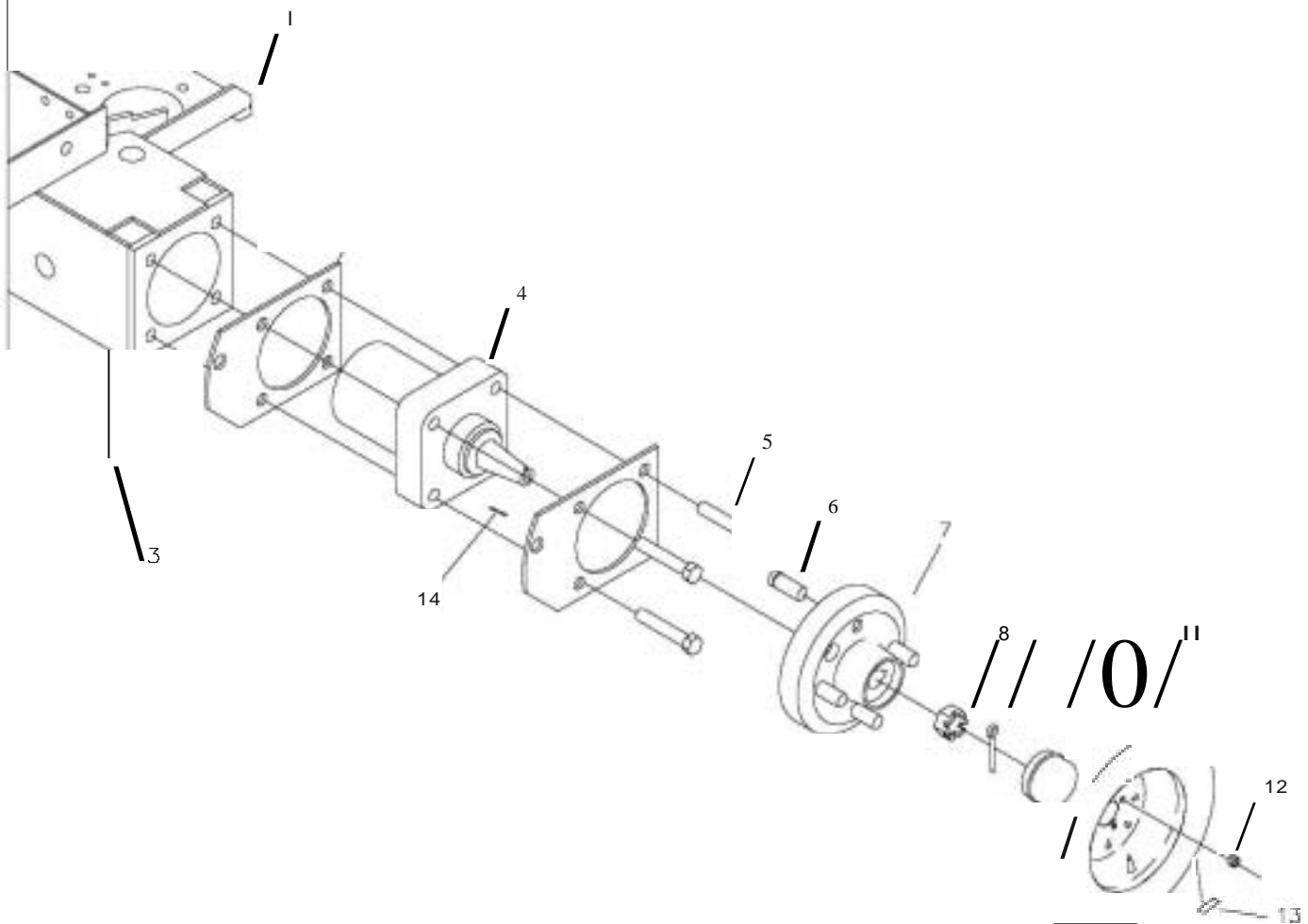

REF NO.	PART NO.	QTY.	DESCRIPTION
1	663-070W	1	MOTOR MOUNT
2	647-017P	4	BRAKE MOUNT
3	F-1005-05	8	1/2-13 STOVER NUT
4	0-3667	2	WHEEL MOTOR PARKER "TE" SERIES
5	F-1668	8	1/2-13 X 2 3/4" BOLT GR. 5
6	F-1654	8	WHEEL STUD (REPLACEMENT)
7	647-041P	2	WHEEL HUB
8	F-1909	2	3/4-16 CASTLE NUT
9	F-1396	2	1/8 X 1 1/2" COTTER PIN
10	H-1798	1	GREASE CAP
11	0-3637	2	TIRE/WHEEL ASSEMBLY ON 48" & 52" DECKS
	0-3669	2	TIRE/WHEEL ASSEMBLY ON 60" DECKS
12	F-1499	8	LUG NUT 1/2-20 X 60 OEG.
13	P-11384	1	DECAL, 12 PSI
14	0-1004-01	2	1 4 X 1" KEY

MOTOR ASSEMBLY & RELATED PARTS

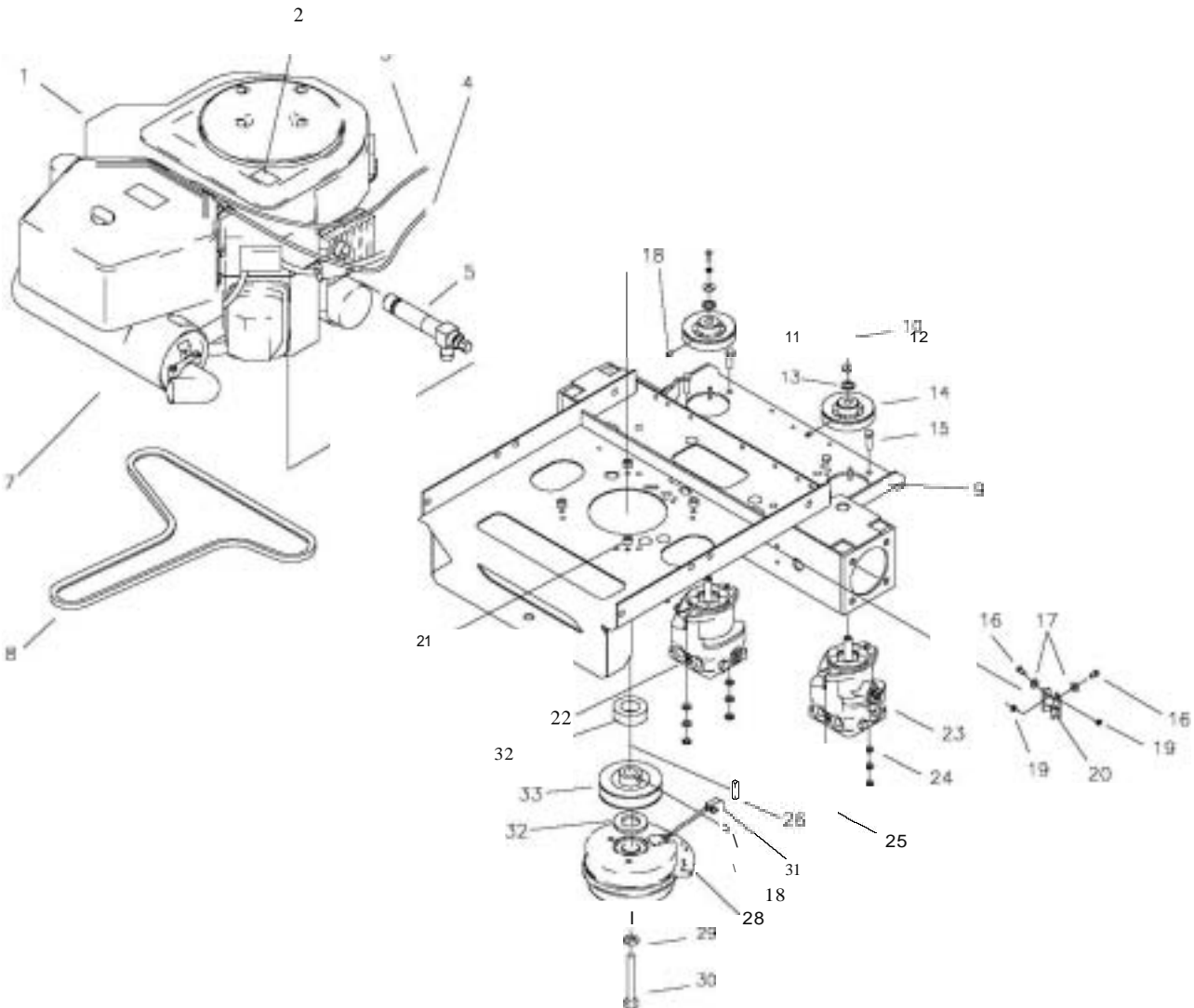

REF NO.	PART NO.	QTY.	DESCRIPTION	REF NO.	PART NO.	QTY.	DESCRIPTION
	M-5325	1	23 HP. KOHLER ENGINE	15	F-1307	4	3/8-16 X 1 1/4" BOLT GR. 5
	M-5327	1	25 HP. KAWASAKI ENGINE	16	F-1015-02	2	1/4-20 X 5/8" BOLT GR. 5
	M-5335	1	27 HP. KOHLER ENGINE	17	F-1009-01	2	1/4" FLAT WASHER
2	p-10on	1	DECAL, "CLEAN"	18	F-1228	2	1/4-20 NYLOC SETSCREW
3	H-2404	1	CHOKE CABLE	19	F-1158	2	1/4-20 STOVER NUT
4	H-2236	1	THROTTLE CABLE	20	659-015W	1	CLUTCH STOP WELDMENT
5	H-2589	1	OIL DRAIN - 3" (KOHLER)	21	F-2046	4	SPACER .3310 X 1.380D X .50 (KAW)
	H-2590	1	OIL DRAIN - 2 1/2" (KAW)	22	0-3770-01	1	HYDRO PUMP (LH)
6				23	0-3770-02	1	HYDRO PUMP (RH)
7	H-2284	1	MUFFLER ASSEMBLY (KAWASAKI)	24	F-1009-03	8	3/8" FLAT WASHER
8	D-3769	1	V-BELT A-67 KEVLAR	25	F-1005-03	4	3/8-16 STOVER NUT
9	663-070W	1	MOTOR MOUNT	26	621-113P	1	KEY, 1/4" SQ. X 1 1/4"
10	F-1737	2	6mm X 16mm BOLT GR. 5	28	E-6247	1	1 1/8" CLUTCH BRAKE
11	F-1738	2	6mm SPRING WASHER	29	F-1019-04	1	7/16 LOCK WASHER
12	F-1736	2	WASHER, .840 X .246 X .125	30	F-1904	1	7/16-20 X 2 1/2" BOLT GR. 5 (KAW)
13	663-046P	2	WASHER, SPACER		F-1756	1	7/16-20 X 3 1/4" BOLT GR. 5 (KOHL)
14	647-035P	2	HYDRO PUMP PULLEY	31	E-64S9	1	CLUTCH PIGTAIL
				32	F-2044	1	SPACER 1.141D X 1.500D X .50(KAW)
				33	647-036P	1	MOTOR PULLEY, 3.75

HIGH PRESSURE LINES & FITTINGS

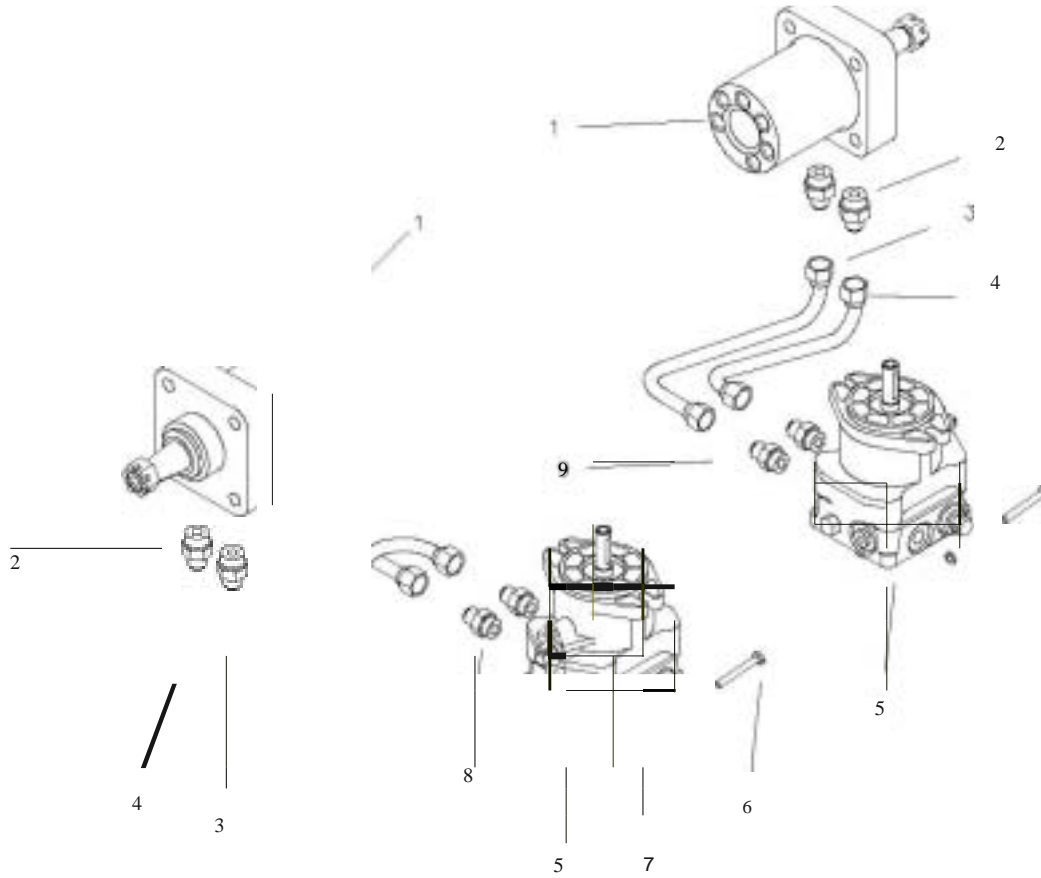

VIEWED FROM FRONT RIGHT

REF NO.	PART NO.	QTY.	DESCRIPTION
1	0-3667	2	WHEEL MOTOR PARKER "TE" SERIES
2	H-2319	4	FinING, STRIGHT, 7/8-14
3	H-2492	2	HOSE ASS'Y 16 1/2"
4	H-2491	2	HOSE ASS'Y 14"
5	-----		SEE PAGE 3-19
6	F-1015-09	2	1/4-20 X 2" BOLT GR. 5
7	F-1158	2	1/4-20 STOVER NUT
8	H-2436	4	FinING, STRAIGHT, 3 4" X 1 2"

OIL RETURN LINES & COOLER ASSEMBLY

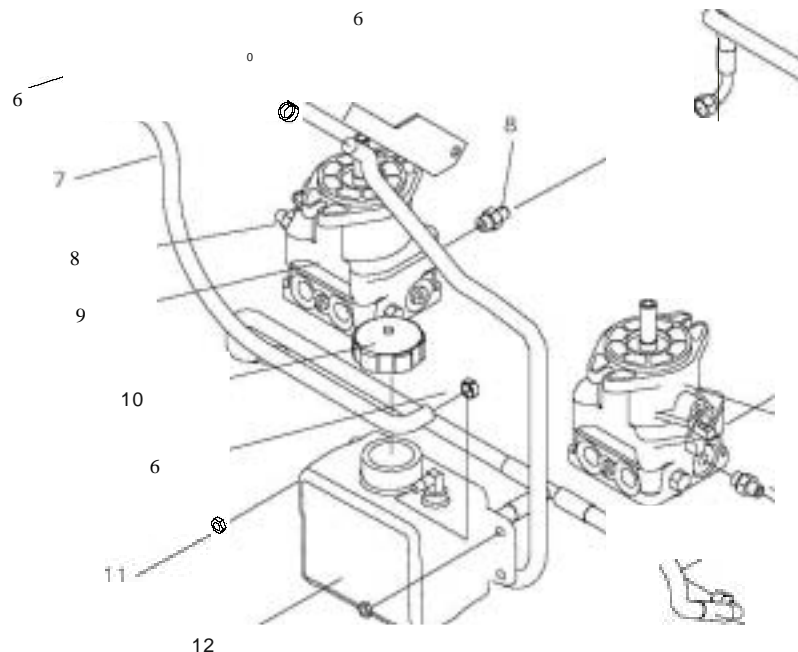
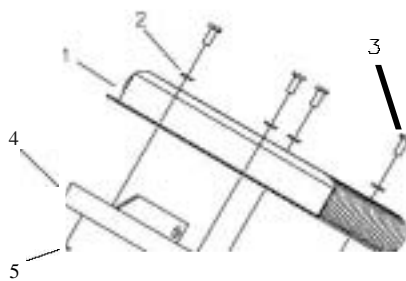

19

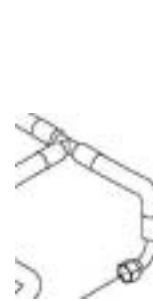

8

9

8

18

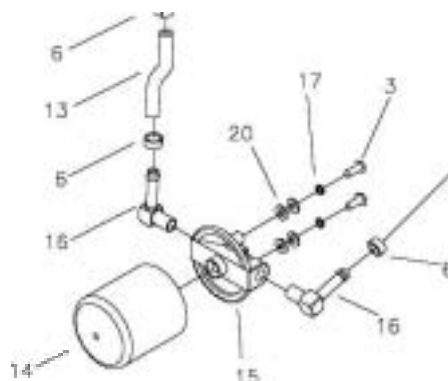

REF NO.	PART NO.	QTY.	DESCRIPTION
1	H-2325	1	OIL COOLER
2	F-1009-01	4	1/4" WASHER
3	F-1015-03	6	1/4-20 X 3/4" BOLT GR. 5
4	647-046W	1	OIL COOLER BRACKET
5	F-115B	4	1/4-20 STOVER NUT
6	H-2282	6	HOSE CLAMP
7	H-2438	1	24" HOSE. 3/8" 10. HI TEMP.
8	H-2330	4	9/16" ADAPTER
9	-----		SEE PAGE 3-19
10	H-2120		VENT CAP

REF NO.	PART NO.	QTY.	DESCRIPTION
11	F-1125	2	5/16-18 STOVER NUT
12	H-2447	1	OIL TANK
13	H-2437	1	4 1/4" HOSE, 3/8 Id. HI TEMP.
14	H-2026	1	OIL FILTER
15	H-2061	1	FILTER BASE
16	H-1859	2	HOSE BARB 90 OEG. ELBOW
17	F-1019-01	2	1/4" LOCK WASHER
18	H-244D	1	RETURN HOSE TEE ASSEMBLY
19	H-2439	1	SUCTION HOSE TEE ASSEMBLY
20	F-10D9-01	4	1 4" FLAT WASHER

E-6415 WIRE HARNESS & RELATED PARTS

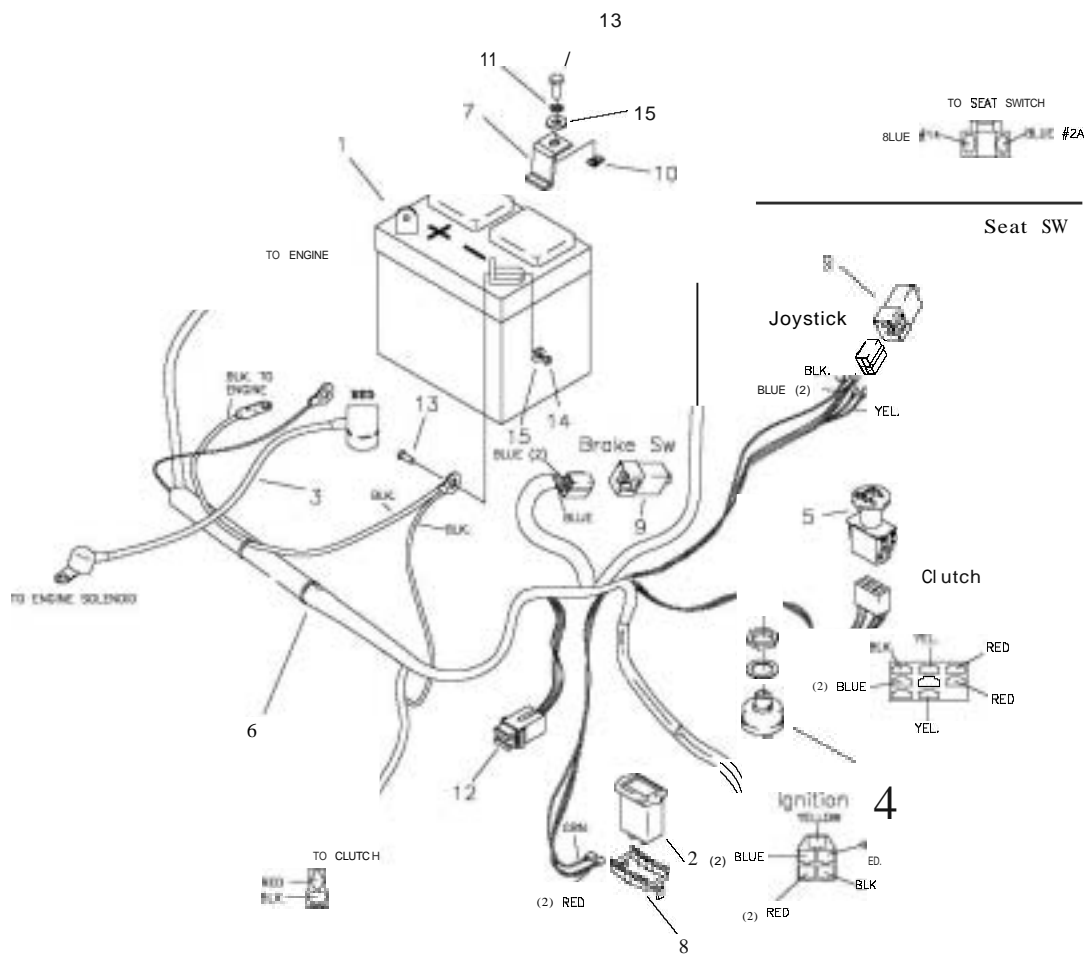

REF NO.	PART NO.	QTY.	DESCRIPTION
1	E-5812	1	BATTERY
2	E-5878	1	HOUR METER
3	E-6418	1	CABLE, BATTERY TO SOLENOID
4	E-5873	1	START SWITCH
5	E-6403	1	CLUTCH SWITCH
6	E-6405	1	WIRE HARNESS
7	661-092P	1	BATTERY HOLD DOWN
8	E-6369	1	RETAINER CLIP
9	E-6297	2	BRAKE SWITCH
10	F-1858	1	1/4-20 U-NUT
11	F-1D19-01	1	1/4" LOCK WASHER
12	E-6207	2	FUSE, #ATC-30
13	F-1538	3	1/4-20 X 3/4" GR. 5
14	F-1158	2	1/4-20 LOCK NUT
15	F-1009-01	5	1/4" FLAT WASHER
	E-6281		COVER (KEY SWITCH) -NOT SHOWN-

E-6416 WIRE HARNESS & RELATED PARTS

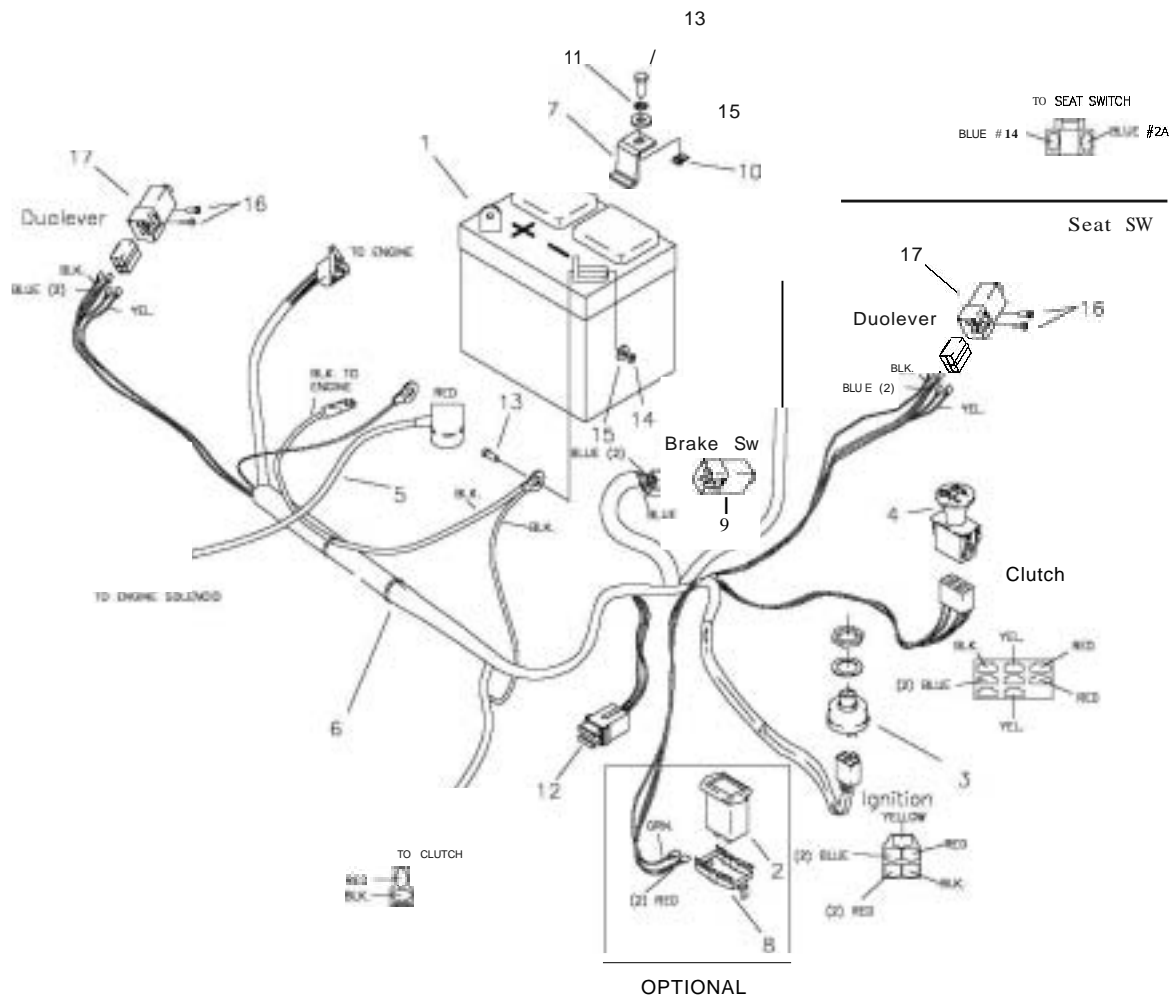

REF NO.	PART NO.	QTY.	DESCRIPTION
1	E-5812	1	BATTERY
2	E-5878	1	HOUR METER
3	E-5873	1	START SWITCH
4	E-6403	1	CLUTCH SWITCH
5	E-6418	1	CABLE, BATTERY TO SOLENOID
6	E-6405	1	WIRE HARNESS
7	661-092P	1	BATTERY HOLD DOWN
8	E-6369	1	RETAINER CLIP
9	E-6297	3	BRAKE SWITCH
10	F-1 B58	1	1/4-20 U-NUT
11	F-1019-01	1	1/4" LOCK WASHER
12	E-6207	2	FUSE, #ATC-30
13	F-1538	3	1/4-20 X 3/4" GR. 5
14	F-1158	2	1/4-20 LOCK NUT
15	F-1009-01	5	1/4" FLAT WASHER
16	F-1994	4	#10 SCREW, 5/8" LONG
17	647-112A	2	SWITCH ARM ASSEMBLY
	E-6281		COVER (KEY SWITCH) -NOT SHOWN-

E-6417 KAWASAKI ADAPTER HARNESS & RELATED PARTS

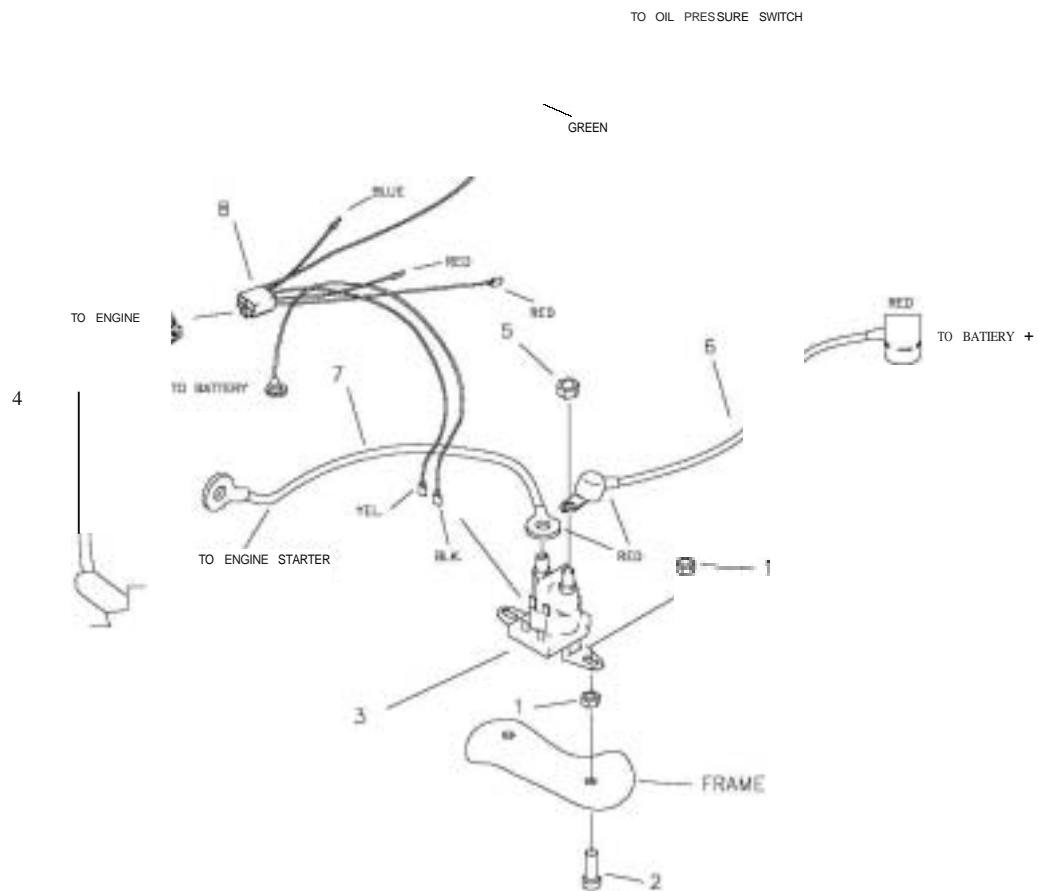

REF NO.	PART NO.	QTY.	DESCRIPTION
1	F-1158	4	1/4-20 LOCK NUT
2	F-1015-05	2	1/4-20 X 1" GR. 5
3	E-6054	1	SOLENOID
4	E-6415 or E-6416	1	KOHLER WIRE HARNESS (JOYSTICK) KOHLER WIRE HARNESS (TWINSTICK)
5	F-1011-01	2	1/4-20 NUT
6	E-6418	1	CABLE, BATTERY TO SOLENOID
7	E-6419	1	CABLE, SOLENOID TO ENGINE
8	E-6417	1	KAWASAKI HARNESS ADAPTER