

# Safety Instructions & Operators Manual

# **COUNTRY** **CLIPPER**<sup>®</sup>

## Zero Turn Radius Mower



SR1005  
SR1010

Congratulations for buying a **Country Clipper** product. Your **Country Clipper** Zero Turning Radius Riding Mower was designed and built to provide long and trouble free service. Keep in mind that it, like any other mechanical device, can be potentially dangerous if used improperly, and hazard control and accident prevention are dependent upon the awareness, concern, prudence, and proper training of personnel involved in the operation, transport, maintenance, and storage of the equipment. Study this manual and pay special attention to the important Safety Precautions on pages 3-6. Following these instructions will help you continue to enjoy the trouble-free performance expected of the **Country Clipper** product.

TABLE OF CONTENTS

<b><i>SAFETY</i></b> .....	<b>3</b>
ACCIDENT PATTERNS TO AVOID .....	3
SAFETY INSTRUCTIONS AND RECOMMENDATIONS .....	3
SAFETY INTERLOCK SYSTEM .....	5
<b><i>START UP AND OPERATION</i></b> .....	<b>6</b>
CHECKLIST BEFORE OPERATION .....	6
CONTROL LOCATIONS JOYSTICK MODELS .....	6
OPERATION JOYSTICK MODELS .....	7
CONTROL LOCATIONS TWINSTICK MODELS .....	8
OPERATION TWINSTICK MODELS .....	8
MOWING RECOMMENDATIONS .....	10
<b><i>MAINTENANCE</i></b> .....	<b>11</b>
MAINTENANCE SCHEDULE .....	11
MAINTENANCE INSTRUCTIONS .....	12
BELT ROUTINGS .....	18
PROCEDURE FOR RAISING AND LOWERING THE DECK FOR SERVICING .....	19
LEVELING THE DECK .....	20
ADJUSTING THE LATCH PLATE .....	21
<b><i>TROUBLE SHOOTING CHECK LIST</i></b> .....	<b>22</b>
<b><i>WIRING SCHEMATIC FOR KOHLER JOYSTICK (E-6415)</i></b> .....	<b>24</b>
<b><i>WIRING SCHEMATIC FOR KAWASAKI JOYSTICK (E-6415) PLUS (E-6417) ADAP</i></b> .....	<b>25</b>
<b><i>WIRING SCHEMATIC FOR KOHLER TWINSTICK (E-6416)</i></b> .....	<b>26</b>
<b><i>WIRING SCHEMATIC FOR KAWASAKI TWINSTICK (E-6416) PLUS (E-6417) ADAP</i></b> ...	<b>27</b>
<b><i>HYDRAULIC SCHEMATIC:</i></b> .....	<b>28</b>
<b><i>NOTES / SERVICE RECORDS:</i></b> .....	<b>28</b>

## SAFETY

### ACCIDENT PATTERNS TO AVOID

- I. **CONTACT WITH THE ROTATING BLADE** -- This accident usually happens when the operator is clearing the discharge chute of grass, (especially when the grass is wet), or when the operator adjusts the machine without turning it off and waiting for the blades to completely stop.
- II. **PROPELLED OBJECTS** -- Sticks, rocks, wires, and other objects can be propelled out through the discharge chute or from under the mower housing. Bystanders are particularly vulnerable.
- III. **GRASS CATCHER OR GUARD** -- The mower shall not be operated without either the entire grass catcher or guard in place.
- IV. **OVERTURNING** -- This happens when riding mowers are used on steep slopes, embankments or hills. The operator in these cases can come in contact with the blades or sustain injuries during a fall.
- V. **MOWER RUNNING OVER THE VICTIM** -- This usually happens when a riding mower is driven in reverse. The accident victims are most often young children whom, unseen by the operator of the mower, were in the area being mowed.

AT **COUNTRY CLIPPER**, WE SHARE YOUR DESIRE TO PROTECT YOURSELF, YOUR FAMILY, YOUR FRIENDS AND YOUR NEIGHBORS FROM ACCIDENTAL INJURY. OBSERVING AND ENFORCING THE FOLLOWING GUIDELINES WILL HELP TO INSURE THE SAFETY OF EVERYONE.

**PLEASE BE CAREFUL!**

### SAFETY INSTRUCTIONS AND RECOMMENDATIONS

1. **PEOPLE WHO OPERATE, SERVICE, OR ARE OTHERWISE ASSOCIATED** with the **Country Clipper** Zero Turning Radius Mower should be trained in its proper use and warned of its dangers. Before operating, adjusting, or servicing the **Country Clipper** Zero Turning Radius Mower they should read and understand this entire manual and the engine owner's manual.
2. **AVOID CONTACT WITH MOVING PARTS.** Keep hands and feet from under mowing deck and away from blades at all times. Turn engine (motor) off if you must unclog the chute.
3. **AVOID HILLS AND SLOPES.** Use extreme caution when mowing up or down slopes. NEVER mow across the face of a slope. If a slope must be ascended, back up the slope; drive forward when descending. Reduce speed and use caution to start, stop and maneuver. To prevent loss of control on a slope avoid sharp turns, sudden changes in direction, and sudden stops and starts.
4. **DISENGAGE POWER TO MOWER BEFORE BACKING UP.** Do not mow in reverse unless ABSOLUTELY necessary and then only after turning around and observing the entire area behind the mower. Go slowly. Most "running over victim" accidents occur in reverse.
5. **BEGINNING OPERATORS SHOULD LEARN HOW TO STEER** the **Country Clipper** Zero Turning Radius Mower before attempting to mow. Start with slow engine speed and drive without the blades engaged in an open area until comfortable with the machine.
6. **KNOW HOW TO STOP QUICKLY.** Know the location and operation of every control, especially how to brake and how to disengage the mower blades.

7. **DO NOT MOVE CONTROL LEVER(S)** from forward position to reverse position rapidly. The speed and/or direction of travel is affected instantly by movement of the Control Lever(s).
8. **DO NOT ALLOW CHILDREN TO OPERATE MOWER.** Do not allow others who have not had instruction to operate mower.
9. **ALWAYS TURN ENGINE OFF AND REMOVE KEY** before leaving the mower to prevent children and inexperienced operators from starting the engine. Never leave the mower unattended with engine running. Always wait for all moving parts and all sounds to stop before leaving operator's seat.
10. **WEAR STURDY, ROUGH-SOLED WORK SHOES AND CLOSE-FITTING SLACKS AND SHIRTS.** Never operate mower in bare feet, sandals or sneakers.
11. **KNOW THE AREA YOU ARE TO MOW.** Watch for hidden danger such as rocks, roots, sticks, holes, bumps, and drop-offs, etc. Before mowing, pick up all debris in area to be mowed. Sharp and hard objects can be propelled at a high speed and can act like shrapnel. Walk through tall grass **BEFORE MOWING** to make sure there are no hidden dangers. Mow higher than desired in tall grass to expose any hidden objects and/or obstacles, clean the area, and then mow to the desired height.
12. **NEVER REFUEL A MOWER INDOORS.** Allow the engine time to cool before refueling. Unseen vapors may be ignited by a spark. Always clean up spilled gasoline. Never run the engine indoors in a garage or any other closed building. Allow engine to cool before storing in any enclosure. The engine exhaust and gasoline fumes are dangerous.
13. **DISENGAGE BLADES BEFORE DRIVING ACROSS WALKS** or projecting objects.
14. **NEVER REMOVE THE FUEL CAP** or add gasoline to a running or hot engine that has not been allowed to cool for several minutes after running. Always make sure the gas cap is in place.
15. **NEVER CARRY PASSENGERS.**
16. **DO NOT SMOKE AROUND THE MOWER** or the gasoline storage container. Gasoline fumes can easily ignite.
17. **KEEP GASOLINE IN A WELL-VENTILATED AREA** away from your living quarters and in tightly-capped safety cans. Never store mower with gasoline in the tank inside a building where fumes may reach open flame or spark.
18. **DISENGAGE BLADES, STOP ENGINE AND REMOVE IGNITION KEY** before any servicing. Be sure all moving parts and all sounds have stopped. Let engine cool and disconnect the spark plugs so the engine cannot start by accident. A SLIGHT ROTATION OF THE BLADES COULD START THE ENGINE.
19. **KEEP ALL NUTS, BOLTS, AND SCREWS TIGHT** to be sure equipment is in safe working condition, especially blade mounting bolts.
20. **VEHICLE SHOULD BE STOPPED AND INSPECTED FOR DAMAGE** after striking a foreign object and the damage should be repaired before restarting and operating the equipment. Stop immediately and check for damage or loose parts if mower should start vibrating.
21. **KEEP SAFETY DEVICES AND GUARDS IN PLACE.** If any of the safety switches become inoperable, have them repaired immediately.
22. **DO NOT STEP OR STAND ON THE MOWER HOUSING.** Step or stand only on the foot deck.
23. **WATCH OUT FOR TRAFFIC** near roadways and when crossing roads.
24. **DO NOT USE MOWER WHEN GRASS IS WET OR SLIPPERY.**
25. **MOW ONLY DURING DAYLIGHT.**
26. **THIS MACHINE IS NOT MEANT FOR HIGHWAY OR STREET USE.** It is not a recreational vehicle and it should not be operated as such.

27. **ALWAYS DISENGAGE THE MOWER BLADE CLUTCH** when transporting.
28. **KEEP ALL SAFETY LABELS IN LEGIBLE CONDITION.** Remove grease, dirt, grass, etc. that may cover safety labels. Replace any safety label that is missing or damaged.
29. **WEAR PERSONAL PROTECTIVE EQUIPMENT.** Eye, ear, feet and head protection is recommended.
30. **ONLY USE COUNTRY CLIPPER APPROVED ACCESSORIES.**
31. **DO NOT CHANGE THE ENGINE GOVERNOR SETTING** or over speed the engine.
32. **BEWARE OF MOWER DISCHARGE DIRECTION** and do not point it at anyone.
33. **DO NOT OPERATE THE MOWER UNDER THE INFLUENCE OF ALCOHOL OR DRUGS.**
34. **USE CARE WHEN LOADING OR UNLOADING MACHINE INTO A TRAILER OR TRUCK.**
35. **USE CARE WHEN APPROACHING BLIND CORNERS,** shrubs, trees, or other objects that may obscure vision.
36. **CLEAN ALL GRASS AND DEBRIS FROM MACHINE TO PREVENT FIRES.** Remove spilled oil or gasoline.
37. **KEEP HANDS AND FEET AWAY FROM MOVING PARTS.** If possible do not make adjustments with the engine running.
38. **NEVER MOW WHEN OTHER PEOPLE OR PETS ARE IN THE AREA.**
39. **CAREFULLY RELEASE PRESSURE FROM COMPONENTS WITH STORED ENERGY.**
40. **USE CARE WHEN REPLACING BLADES.** Wrap the blade(s) or wear gloves, and use caution when servicing them. Only replace blade(s). Never straighten or weld blade(s).
41. **USE JACKSTANDS TO SUPPORT COMPONENTS** when required.
42. **KEEP BODY AND HANDS AWAY FROM PIN HOLES OR LEAKS IN HIGH PRESSURE HYDRAULIC LINES.** Always use paper or cardboard to search for leaks, **NEVER** use hands. Make sure all hydraulic connections are tight and that hydraulic lines are in good condition before starting the engine.

## SAFETY INTERLOCK SYSTEM

Your *Country Clipper* Zero Turning Radius Mower is equipped with switches interlocked for your safety.

**ON JOYSTICK MODELS** GROUND DRIVE NEUTRAL IS WHEN THE JOYSTICK (CONTROL LEVER) IS IN THE “**DOWN**” POSITION.

**ON TWINSTICK MODELS** GROUND DRIVE NEUTRAL IS WHEN BOTH CONTROL LEVERS ARE IN THE “**OUT**” POSITION.

1. The mower blades must be disengaged before engine will start.
2. The Control Lever(s) must be in the neutral position before the engine will start.
3. The engine will stop if the mower blade clutch is engaged when the operator leaves the driver’s seat.
4. The engine will stop if the Control Lever(s) are not in the neutral position when the operator leaves the driver’s seat.
5. The engine will stop if the brake is “**SET**” and the Control Lever(s) are not in the neutral position.
6. The engine will stop if the brake is “**SET**” and the mower blade clutch is engaged.

**DO NOT OPERATE MOWER IF SAFETY SWITCHES AND GUARDS ARE NOT OPERATING PROPERLY**

# START UP AND OPERATION

## CHECKLIST BEFORE OPERATION

1. Make sure fuel tank is full. Use regular unleaded gasoline (see engine owner's manual for more details).

**! WARNING !**

**HANDLE GASOLINE WITH CARE -- IT IS HIGHLY FLAMMABLE. DO NOT SMOKE. ENGINE SHOULD BE OFF AND COOL. USE APPROVED GAS CONTAINER. NEVER FILL TANK INDOORS. WIPE UP ANY SPILLS. REPLACE CAP TIGHTLY.**

2. Make sure dirt and foreign matter is kept out of gas tank. Use a clean funnel and gas can.
3. Do not mix oil with gasoline.
4. Do not use white, high test or premium gasoline. Do not use de-icers, carburetor cleaners, or other such additives.
5. Check the crankcase oil level. Make sure the engine is off. The mower should be parked on a level area. Do not overfill. (See your engine manual for more detailed instruction.)
6. Check battery fluid level.
7. Inspect V-belts.
8. Check tire pressure:
9. Make sure underside of mower deck is

Model	Front tires	Rear tires
All Models	12 psi	12 psi

- free of grass.
10. Make sure mower blades are sharp and secured tightly.
11. Clean the air intake screen on the engine if necessary.
12. Perform any other maintenance as it becomes necessary. (See the "Maintenance" section of this manual.)

**IMPORTANT:** Before cutting grass, clutch must be broken-in as follows: With engine at full RPM engage deck until blades come to full speed and then disengage until blades come to a complete stop. Repeat 10 times to "break-in" the clutch properly.

## CONTROL LOCATIONS JOYSTICK MODELS

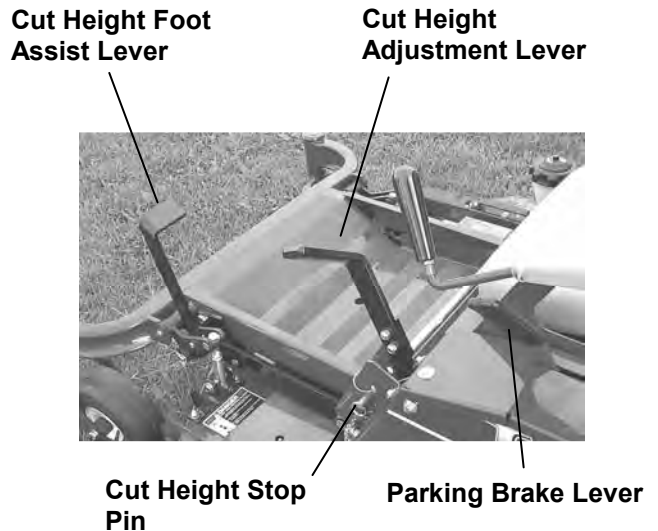
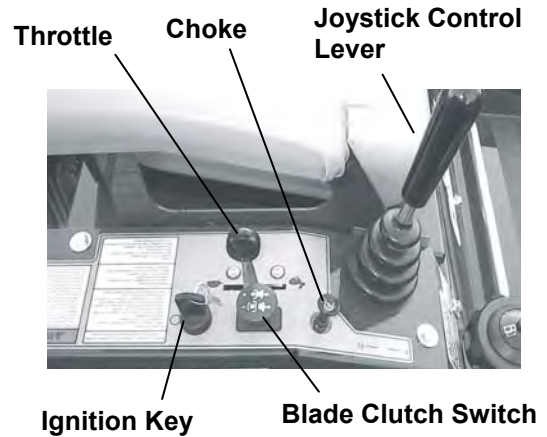

**! WARNING !**

**AVOID INHALING EXHAUST FUMES -- CARBON MONOXIDE GAS IS COLORLESS AND ODORLESS, AND CAN CAUSE UNCONSCIOUSNESS, AND IS POTENTIALLY LETHAL. DO NOT RUN LAWN MOWER IN GARAGE OR OTHER CONFINED AREA.**

## OPERATION JOYSTICK MODELS

1. MOVE JOYSTICK CONTROL LEVER TO neutral “DOWN” position.
2. SET PARKING BRAKE. Pull up to set.
3. DISENGAGE MOWER BLADE CLUTCH by moving clutch switch to “OFF” position.
4. PULL ENGINE CHOKE CONTROL to full position for cold starts.
5. SET ENGINE THROTTLE TO 1/2 THROTTLE.
6. TURN IGNITION KEY to “START” position and release to “RUN” as soon as engine starts. NOTE: Prolonged cranking will damage starter motor and shorten the battery life
7. ADJUST ENGINE THROTTLE AND CHOKE for desired engine smoothness and speed. NOTE: When mowing, always run engine at full throttle.
8. RELEASE PARKING BRAKE. Push brake lever down to release.

**IMPORTANT:** Until the operator is familiar with the *Country Clipper* Zero Turning Radius Mower, he/she should follow these recommendations: Disengage the mower blades. Go very slowly until thoroughly familiar with the machine. Keep away from fences, buildings, and other obstructions. Move the Joystick Control Lever smoothly and slowly. Practice until operation is smooth and efficient.

9. TO DRIVE:
  - A. Move the Joystick Control Lever to the “UP” position.
  - B. Move the Joystick Control Lever forward to move forward. Increasing forward movement of the Joystick Control Lever will increase the speed of travel.
  - C. To reverse the direction, pull the Joystick Control Lever slightly back.

- D. To turn, move the Joystick Control Lever toward the direction you want to turn..
- E. To turn on a zero radius axis, go slowly and move the Joystick Control Lever to the side you wish to turn and slightly to the rear at the same time.



### **CAUTION**



**FOR SMOOTH, SAFE OPERATION, MOVE THE JOYSTICK CONTROL LEVER IN A GENTLE, SLOW MOTION. NEVER PULL OR PUSH THE JOYSTICK CONTROL LEVER RAPIDLY, ESPECIALLY ON GRADES.**

10. BRAKING: To brake mower, gently move the Joystick Control Lever in the direction opposite to travel. If the parking brake is engaged with the Joystick Control Lever in the “UP” position the engine will stop.
11. CUTTING HEIGHT ADJUSTMENT: With the Cut Height Adjustment Lever latched into the top cut height latch. Insert Cut Height Stop Pin to desired cutting height. Pull Cut Height Adjustment Lever rearward and then to the left to clear top cut height latch. Lower Cut Height Adjustment Lever until it rests on Cut Height Stop Pin. NOTE: Pushing on the Cut Height Foot Assist Lever will make the Cut Height Adjustment Lever easier to operate.
12. ENGAGE MOWER BLADE CLUTCH: Set the Blade Clutch Switch to the “ON” position. The engine will not start if the blade clutch is engaged. If the operator is not in the seat, the engine will stop if the clutch is engaged.



## **CAUTION**



**AVOID HILL AND SLOPES. USE EXTREME CAUTION WHEN MOWING UP OR DOWN SLOPES. NEVER MOW ACROSS THE FACE OF A SLOPE. IF A SLOPE MUST BE ASCENDED, BACK UP THE SLOPE; DRIVE FORWARD WHEN DESCENDING.**

### **13. TO STOP:**

- A.** Move Joystick Control Lever to neutral position and then to the “DOWN” position.
- B.** Disengage the mower blade clutch by moving the clutch to the “OFF” position.
- C.** Set the parking brake.
- D.** Slow engine speed with throttle to slowest position.
- E.** Turn ignition key to “OFF” position.
- F.** Remove the key and wait for all movement and all sound to cease before dismounting.

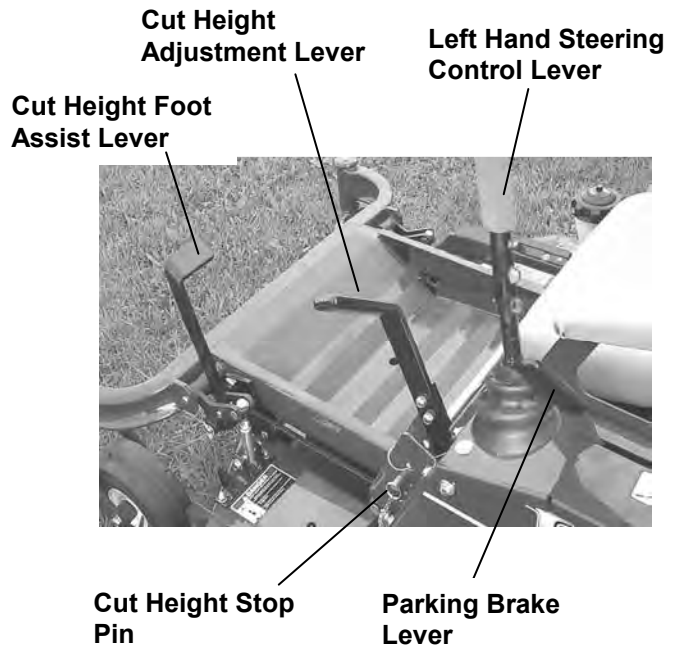

## **WARNING**



**AVOID INHALING EXHAUST FUMES -- CARBON MONOXIDE GAS IS COLORLESS AND ODORLESS, AND CAN CAUSE UNCONSCIOUSNESS, AND IS POTENTIALLY LETHAL. DO NOT RUN LAWN MOWER IN GARAGE OR OTHER CONFINED AREA.**

### **CONTROL LOCATIONS TWINSTICK MODELS**

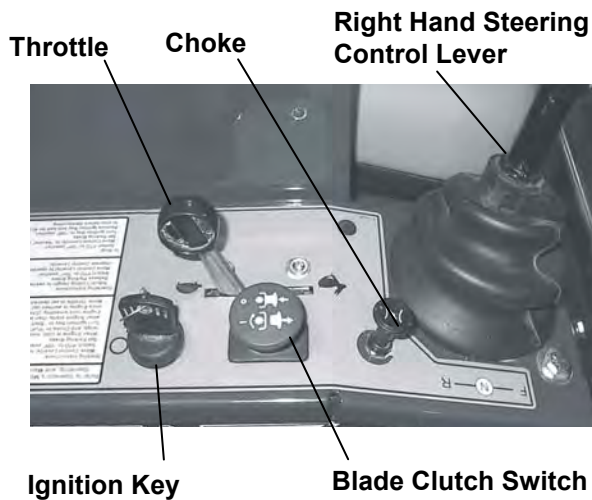

### **OPERATION TWINSTICK MODELS**



- 1.** MOVE STEERING CONTROL LEVERS TO neutral “OUT” position.
- 2.** SET PARKING BRAKE. Pull up to set.
- 3.** DISENGAGE MOWER BLADE CLUTCH by moving clutch switch to “OFF” position.
- 4.** PULL ENGINE CHOKE CONTROL to full position for cold starts.
- 5.** SET ENGINE THROTTLE TO 1/2 THROTTLE.
- 6.** TURN IGNITION KEY to “START” position and release to “RUN” as soon as engine starts. NOTE: Prolonged cranking will damage starter motor and shorten the battery life.
- 7.** ADJUST ENGINE THROTTLE AND CHOKE for desired engine smoothness and speed. NOTE: When mowing, always run engine at full throttle.
- 8.** RELEASE PARKING BRAKE. Push brake lever down to release.



**IMPORTANT:** Until the operator is familiar with the Zero Turning Radius Mower, he/she should follow these recommendations. Disengage the mower blades. Go very slowly until thoroughly familiar with the machine. Keep away from fences, buildings, and other obstructions. Move the Steering Control Levers smoothly and slowly. Practice until operation is smooth and efficient.

**9. TO DRIVE:**



- A.** Move the Steering Control Levers to the "IN" position.
- B.** Move the Steering Control Levers forward to move forward. Increasing forward movement of the Steering Control Levers will increase the speed of travel.
- C.** To reverse the direction, pull the Steering Control Levers slightly back.
- D.** To turn, move one Steering Control Lever slightly ahead of the other.
- E.** To turn on a zero radius axis, go slowly and move one Steering Control Lever forward and one Steering Control Lever rearward. (For a right hand turn the left hand Steering Control Lever will be ahead of the right hand Steering Control. For a left hand turn the right hand Steering control will be ahead of the left hand Steering Control.)

 **CAUTION**   
**FOR SMOOTH, SAFE OPERATION, MOVE THE STEERING CONTROL LEVER(S) IN A GENTLE, SLOW MOTION. NEVER PULL OR PUSH THE STEERING CONTROL LEVER(S) RAPIDLY, ESPECIALLY ON GRADES.**

**10. BRAKING:** To brake mower, gently move the Steering Control Levers in the direction opposite to travel. If the parking brake is engaged with the Steering Control Lever(s) in the "IN" position the engine will stop.



**11. CUTTING HEIGHT ADJUSTMENT:** With the Cut Height Adjustment Lever latched into the top cut height latch. Insert Cut Height Stop Pin to desired cutting height. Pull Cut Height Adjustment Lever rearward and then to the left to clear top cut height latch. Lower Cut Height Adjustment Lever until it rests on Cut Height Stop Pin. **NOTE:** Pushing on the Cut Height Foot Assist Lever will make the Cut Height Adjustment Lever easier to operate.

**12. ENGAGE MOWER BLADE CLUTCH:** Set the Blade Clutch Switch to the "ON" position. The engine will not start if the blade clutch is engaged. If the operator is not in the seat, the engine will stop if the clutch is engaged.

 **CAUTION**   
**AVOID HILL AND SLOPES. USE EXTREME CAUTION WHEN MOWING UP OR DOWN SLOPES. NEVER MOW ACROSS THE FACE OF A SLOPE. IF A SLOPE MUST BE ASCENDED, BACK UP THE SLOPE; DRIVE FORWARD WHEN DESCENDING.**

**13. TO STOP:**

- A.** Move Steering Control Levers to neutral position and then to the "OUT" position.
- B.** Disengage the mower blade clutch by moving the clutch to the "OFF" position.
- C.** Set the parking brake.
- D.** Slow engine speed with throttle to slowest position.
- E.** Turn ignition key to "OFF" position.
- F.** Remove the key and wait for all movement and all sound to cease before dismounting.

 **CAUTION**   
**WHEN LEAVING THE MOWER UNATTENDED, ALWAYS REMOVE THE KEY AND SET THE PARKING BRAKE, EVEN IF JUST FOR A FEW MOMENTS. HELP PROTECT CHILDREN AND OTHER UNAUTHORIZED PERSONS FROM ACCIDENTS.**

14. TO FREE WHEEL MACHINE: UNLOCK TRANSMISSION: Unscrew both bypass valves between ½ to 1 full turn counterclockwise. To reset, turn valves clockwise. **DO NOT OVERTIGHTEN.**

#### Hydrostatic Transmission



**Bypass Valve  
(one on each hydrostatic  
transmission)**

NOTE: The tractor should never be pulled at more than 2 miles per hour or for any appreciable distance.

## MOWING RECOMMENDATIONS

1. Keep mower blades sharp.
2. Make sure deck and discharge are clean.



### **CAUTION**



**POWER MUST BE OFF TO CLEAN  
DISCHARGE CHUTE. TURN ENGINE OFF  
AND WAIT FOR ALL MOVING PARTS TO  
STOP.**

3. When mowing tall grass, make two passes, mowing off 1/2 of the desired cut on the first pass, and then the desired height the second pass. Check for hidden dangers first.
4. Go slowly for trimming.
5. Always cut grass with the engine at full throttle speed. This "ENGINE" speed allows the cutting blades to operate at optimum cutting speed. Control "GROUND" speed with the Control Lever(s).
6. Vary ground speed to suit conditions (i.e. go slower in tall thick grass, on hills, wet conditions, etc.).

## MAINTENANCE



### CAUTION



**BEFORE PERFORMING ANY MAINTENANCE, TURN OFF ENGINE  
REMOVE KEY AND DISCONNECT SPARK PLUGS. USE EXTREME CARE WHEN WORKING ON  
MACHINERY. DO NOT WEAR WATCHES OR JEWELRY. DO NOT WEAR LOOSE FITTING  
CLOTHES, AND OBSERVE ALL COMMON SAFETY PRACTICES WITH TOOLS.**

### MAINTENANCE SCHEDULE

<b>SERVICE</b>	<b>WHEN</b>
Check crankcase oil level -----	before each use
Clean grass from Hydrostatic Transmission fins and oil cooler -----	before each use
Check air intake screen -----	after each use
Clean grass under deck -----	after each use
Check tire pressure -----	every 10 hours
Check battery fluid -----	every 10 hours
Sharpen mower blades -----	every 10 hours
Clean air filter pre-cleaner element -----	every 25 hours
Check Hydrostatic Transmission oil level -----	every 25 hours
Check drive belts -----	every 50 hours (20 hours break-in)
Service Air Cleaner Filter Element -----	every 100 hours
Change engine crankcase oil -----	100 hours
oil filter -----	200 hours
Replace air filter element -----	annually or 500 hours
Check spark plugs -----	annually or 500 hours
Service battery -----	annually or 500 hours
-----	

**Replace decals when illegible. Write factory for free replacement.**

## MAINTENANCE INSTRUCTIONS

### 1. ENGINE:

For complete maintenance and operating information for your engine, please refer to your engine operating and maintenance instructions furnished by the engine manufacturer and included in your **Country Clipper** Zero Turning Radius Mower information packet.

NOTE: Air intake screen must be kept clean. If plugged, engine may be seriously damaged by over heating.

### 2. BATTERY:

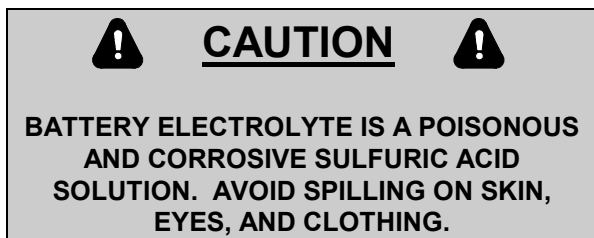

Keep the electrolyte level above the plates in each cell by adding distilled water as it becomes necessary. Add water just before operating the mower to mix the water with the solution. Be careful not to overfill the battery -- the electrolyte solution is corrosive and can cause damage to surrounding metal parts if it should spill. When taking the battery out of the mower for servicing, make sure to connect the cables to the battery exactly as they were prior to removal. Always disconnect the ground ( - ) wire first and always reconnect the ground ( - ) wire last.

Keep the battery clean. Remove the corrosion around the battery terminals by applying a solution of one part baking soda to four parts water. Coat all exposed terminal surfaces with a light layer of grease or petroleum jelly to prevent corrosion.

NOTE: At temperatures below 32 degrees F (0 degrees C) the full charge state must be maintained to prevent cell electrolyte from freezing and causing permanent battery damage.

### 3. TIRES:

Correct tire pressure is essential for efficient operation of the mower. Check tire pressure as requested in the maintenance schedule. Inflate tires to the pressures listed below:

Model	Front tires	Rear tires
All Models	12 psi	12 psi

Lug nuts should be torqued to 75 ft/lbs and checked regularly for tightness.

### 4. MOWER BLADES:

Check sharpness of mower blades after every 10 hours of operation. To sharpen blades proceed as follows:



- A. Remove bolt, lockwasher, and cup washer mounting blade on shaft. Remove blade.
- B. Blades should be discarded when worn excessively.

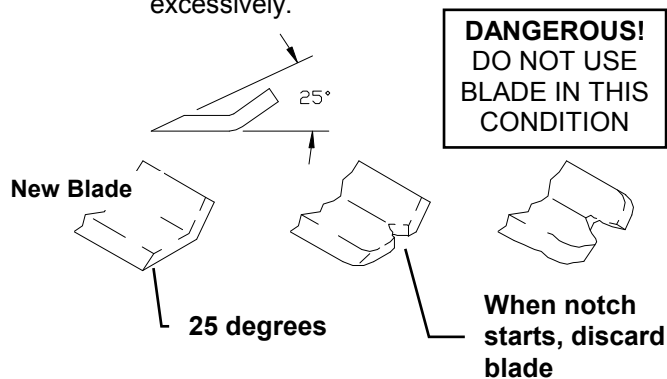

- C. Sharpen blades with a hand file, electric grinder or blade sharpener. Wear gloves and eye protection when sharpening. Grind blade at original 25 degree bevel.
- D. Check balance of blade by positioning the blade on a nail or blade balance pedestal. Grind the blade on the end that is heavier until both sides balance.
- E. Install blade, cup washer, lockwasher, and bolt. Make sure to tighten bolt to 60 ft.lbs.

## 5. V-BELTS:

All belts should be checked every 50 hours. Replace any belts found to be in poor condition. All belts are equipped with spring loaded belt tighteners and do not require tightening adjustments.

## 6. LUBRICATION:

- A. Engine: Follow engine manufacturer's recommendation.
- B. Deck Spindles: Lubricate with 3 "shots" only, every 100 hours.
- C. Hydrostatic Transmissions: Check oil level in Hydraulic Oil Reservoir after every 25 hours of use. Oil level should be checked when oil is COLD. If necessary add 20W-50 motor oil to the reservoir. **DO NOT OVERFILL.** Thoroughly clean the Hydraulic Oil Reservoir Cap and the surrounding area **PRIOR** to removal of the cap. Take caution to keep all foreign matter out of the Hydraulic Oil Reservoir.

Change the oil in the Hydraulic Oil Reservoir after the first 100 hours of use, and then every 500 hours after that. To change oil, remove the Hydraulic Oil Filter and allow all of the oil to drain from the Hydraulic Oil Reservoir. Replace with a new Hydraulic Oil Filter (P/N H-2026) and 20W-50 Motor Oil.

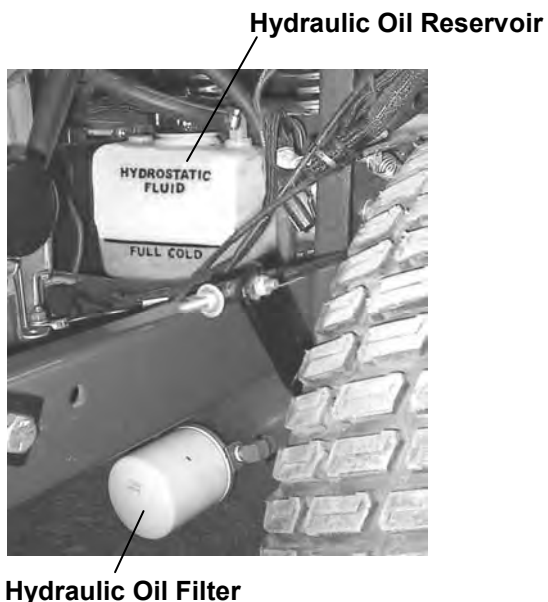

## 7. PARKING BRAKE ADJUSTMENT:

- A. Move Parking Brake Lever to the "OFF" position.
- B. With moderate pressure manually actuate the Lower Brake Arm up and forward. Tighten the Brake Adjustment Nut to have approximately  $\frac{1}{2}$ " of "free-play" between the Brake Adjustment Nut and Brake Anchor Mount.
- C. Repeat for the other side

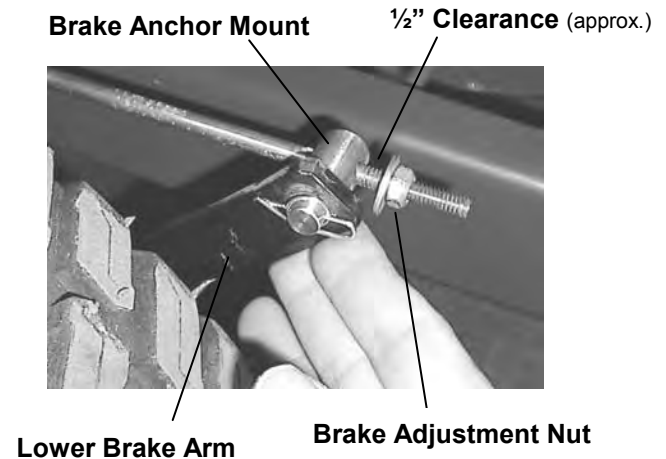

## 8. JOYSTICK CONTROL LEVER NEUTRAL ADJUSTMENT:

With the engine running, if the machine travels in either direction when the Joystick Control Lever is in the neutral "DOWN" position, stop the engine, elevate the rear wheels clear of the ground and adjust as follows:

- A. Remove the right hand fender skirt exposing the Joystick Control Lever Assembly.
- B. Start the engine.
- C. Run engine at fast idle with Joystick Control Lever in the "DOWN" position.
- D. Loosen the locknuts tightened against the rod end ball joints on the Upper Linkage Rod Assembly that corresponds to the wheel that is turning. Note: One of these is a left hand nut and will have to be turned backwards.
- E. Adjust the Neutral Position by turning the rod in the Upper Linkage Rod Assembly until the wheel stops turning.
- F. Retighten the locknuts on Upper Linkage Rod Assembly and check to make sure the drive wheel is still not turning.
- G. Repeat steps B through F for other side.
- H. Shut off engine before removing from blocks. Replace fender skirt.

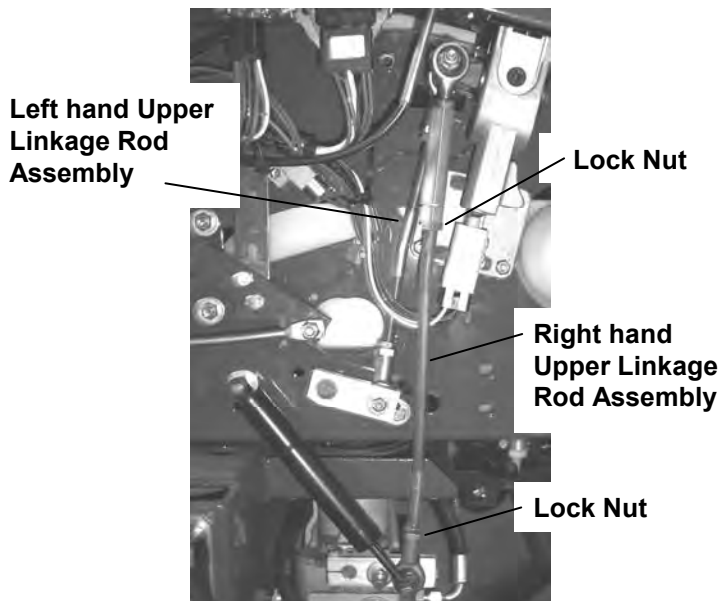

## 9. JOYSTICK CONTROL LEVER SENSITIVITY ADJUSTMENT

To change the sideways turning response adjust as follows:

- A. Remove the right hand fender skirt exposing the Joystick Control Lever assembly.
- B. Remove the cross bolt, nut, and spacers
- C. Reassemble the spacers as desired. (2) spacers between the rod end ball joints and the joystick pivot shaft will quicken the side to side response, (1) spacer slows the response.

**NOTE:** It is important that there is at least one spacer on each side of the rod end ball joints to prevent damage. Also the small diameter of the spacer must point towards the rod end ball joint.

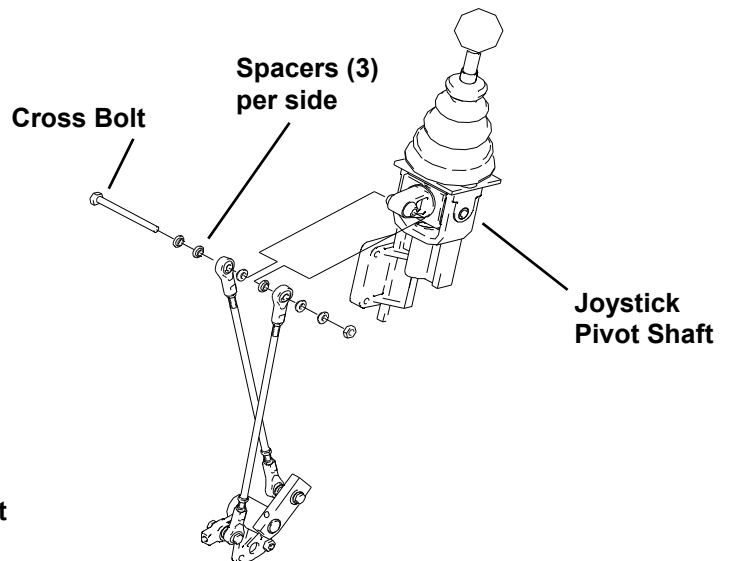

## 10. JOYSTICK CONTROL LEVER DETENT ADJUSTMENT:

If the Joystick Control Lever does not lock in the "UP" position, turn the detent adjustment screw clockwise until a desirable locking action is obtained. If the Joystick Control Lever is hard to slide up and down, turn the detent adjustment screw counter-clockwise until a desirable sliding action is obtained.

**Joystick Assembly**

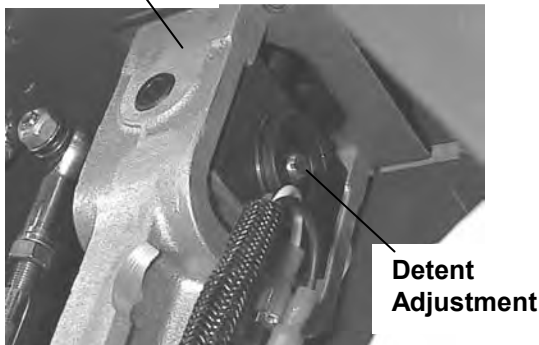

## 11. TWINSTICK CONTROL LEVER NEUTRAL ADJUSTMENT:

- A. Remove the fender skirts from each side of the machine.
  - B. Block up the unit so that the Drive Wheels are off the ground.
  - C. Start the engine and run at a fast idle with the Steering control levers in the "out" position.
  - D. Loosen the locknuts tightened against the rod end ball joints in the Upper Linkage Assembly. (Note: One of these is a left hand nut and will have to be turned backwards.)
  - E. Adjust the Neutral Position by turning the rod in the upper linkage until the wheel stops turning.
  - F. Retighten the nuts on the Upper Linkage Assembly and check to see that the drive wheel is still not turning.
  - G. Repeat steps B-F for the other side.
  - H. Shut off engine before removing the blocks.
- (see Illustration at top of next column)

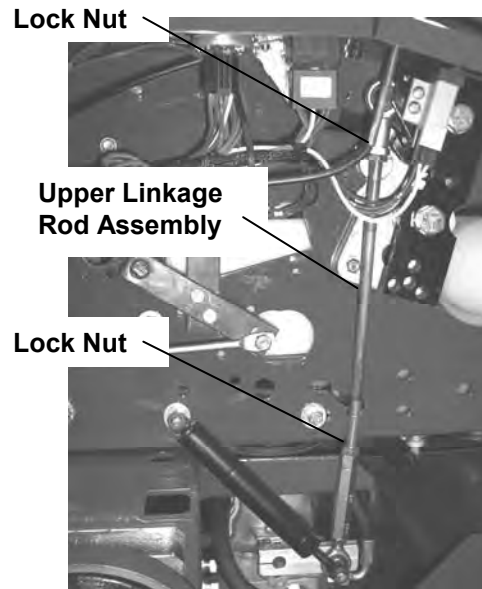

## 12. To Adjust "IN" Position of the Twinstick Steering Control Levers:

- A. Remove the Front Bolts, Nuts and Washers which hold the Fender Cap in place.
- B. Pull the boot from the hole in the fender cap, exposing the cast iron lever.
- C. Using a 5/32" Allen Wrench, turn the setscrew to adjust the stop.
- D. Replace the Boot into the hole in the Fender Cap.
- E. Replace the Front Bolts, Nuts, and Washers.

(see Illustration on next page)

### 13. TO ALIGN TWINSTICK CONTROL LEVER HANDLES FORWARD / REVERSE:

- A. Sit on the seat and push the control levers full forward and full backward. If the ends do not match the handles maybe adjusted as follows:
- B. Locate Setscrew stops in the Steering Control Lever Base which stop the lever in each direction. (Note: The one at the rear is the stop for FWD and the one in the front is the stop for REV.)
- C. Adjust setscrew stops so that handles line-up together when shifted full forward and full reverse.

Access Hole to Control Lever "Forward" Stop

Control Lever "IN" position Stop

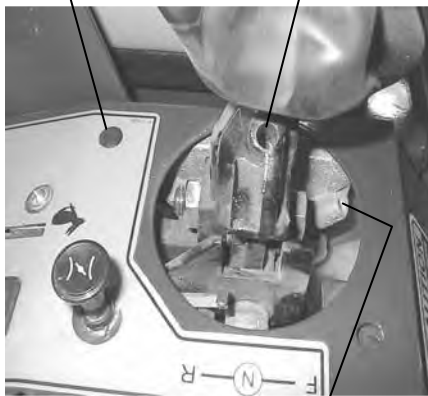

Control Lever "Reverse" Stop

Note: To prevent damage to Control Linkages the Control Lever must always hit on the Stop Screws. Never adjust Stops out so that the Control Lever "bottoms" out another parts of the linkage.

### 14. TO MAKE JOYSTICK MORE RESPONSIVE:

Remove dampener from front dampener mounting stud, reattach to back dampener mounting stud. Move dampeners on both sides.

### 15. ADJUSTING FOR STRAIGHT FORWARD TRACKING (Joystick and Twinstick):

In a large open area, actuate the Control lever(s) into the full forward position. If the mower veers in either direction left or right some adjustment is necessary. If the mower veers to the right, then the right hydrostat needs to be sped up. If the mower veers to the left, then the left hydrostat needs to be sped up.

- A. Stop the machine and shut off the engine.
- B. Slightly loosen the bolt at the lower end of the upper linkage assembly on the side that is slower. Using a 1/8" hex wrench turn the setscrew 1/4 turn in. It may take several test drives to get the mower to track straight forward.
- C. Once the tracking is to the operators liking, completely tighten the bolt on the control linkage assembly that was loosened earlier.
- D. Recheck to make sure neutral adjust has not been effected. Readjust neutral if necessary.

Setscrew to adjust forward tracking

Upper Linkage Assembly

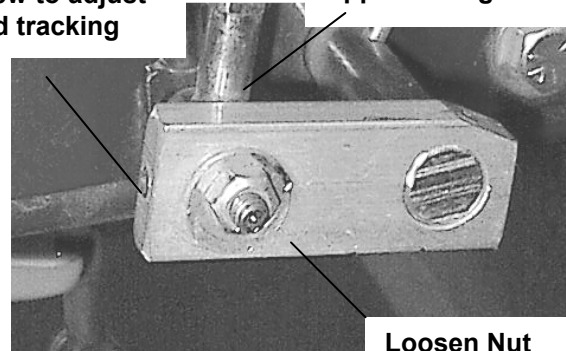

Loosen Nut



## 16. JOYSTICK CONTROL LEVER SHIFTING FORCE ADJUSTMENT:

To change the amount of force required to shift the joystick control lever adjust as follows:

### A. Heavier Force to Shift Joystick

**Control Lever:** Remove e-ring clip from dampener mounting stud. Position dampener onto the heavy dampener mounting stud (top). Re-install the e-ring clip.

### B. Lighter Force to Shift Joystick

**Control Lever:** Remove e-ring clip from dampener mounting stud. Position dampener onto the light dampener mounting stud (bottom). Re-install the e-ring clip.

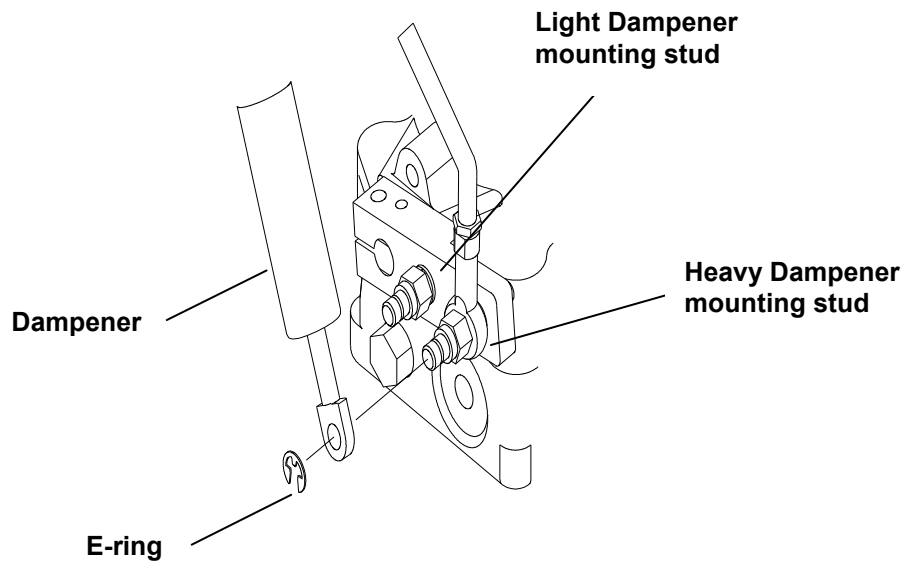

# BELT ROUTINGS

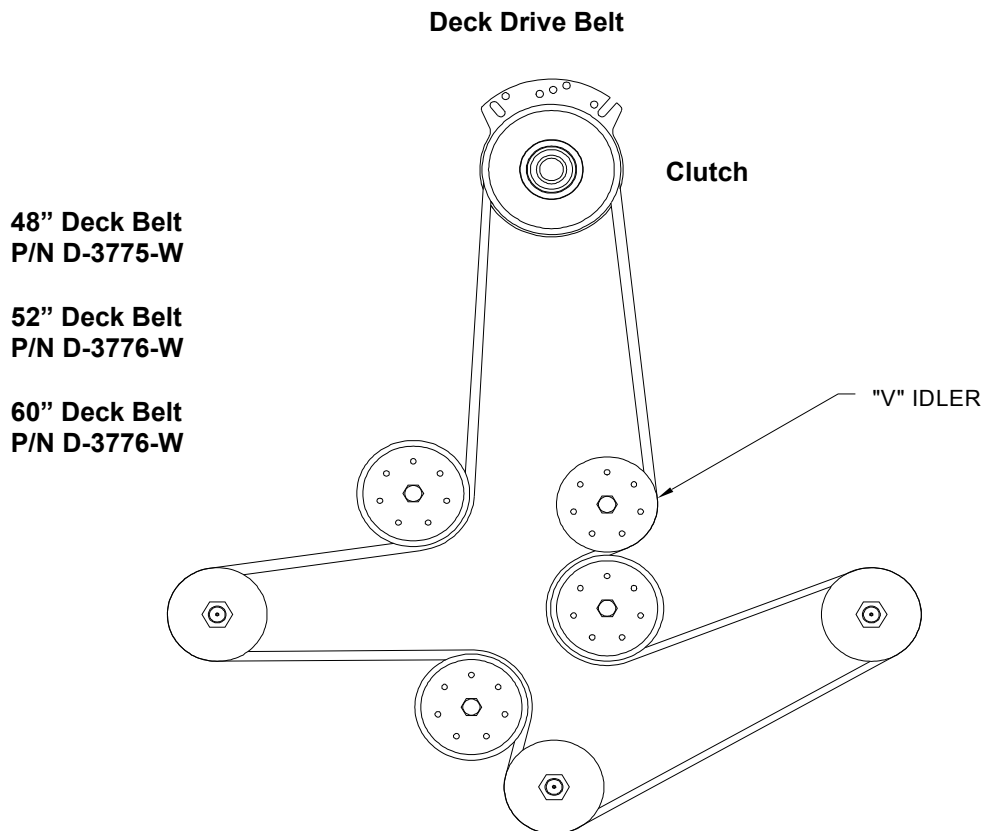
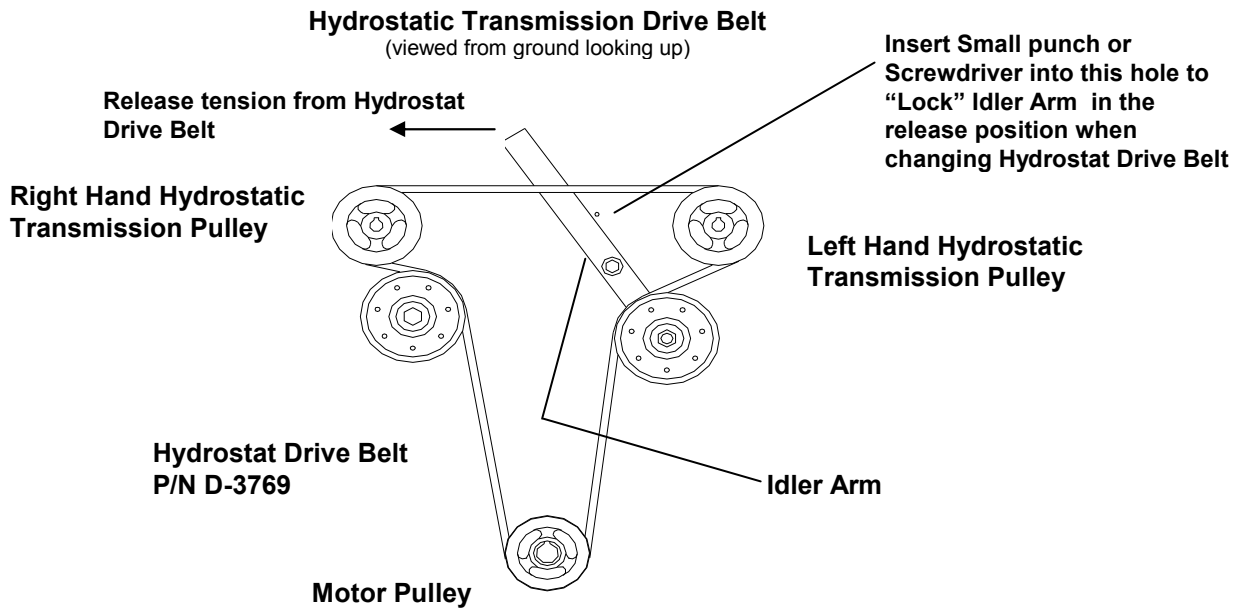

## PROCEDURE FOR RAISING AND LOWERING THE DECK FOR SERVICING

### 1. RAISING THE DECK:

- A. Remove cut height adjustment pin and completely lower the cut height adjustment lever. Re-insert the cut height adjustment pin into the 3-1/2" cut height position (this will lock the cut height adjustment lever into the lowest position).
- B. Release Tension from the Engine to Deck Drive Belt by carefully rotating the Deck Belt Tension Latch. Remove the Engine to Deck Drive Belt from the clutch on the engine.
- C. On the right side of the mower, lift and hold up on the hook keeper. Lift up on the release handle to disconnect the back of the deck. The latch plate should catch and hold the release handle rod in place. (To adjust the latch plate, see Page 21.)
- D. Position the front caster wheels so they are away from the deck (such as the tractor would be traveling in reverse). Flip up the Front Step on units so equipped.
- E. Lift the nose of the deck until the deck is standing vertical (lifting can be made

easier if someone stands on the rear bumper of the tractor). **IMPORTANT NOTE: MAKE SURE THAT THE DECK IS LIFTED FAR ENOUGH TO GO COMPLETELY "OVER-CENTER"**. This will prevent the deck from falling down when servicing the underside of the mower deck.

### 2. LOWERING THE DECK:

- A. Push the bottom (back) of the deck towards the rear of the tractor. Lower the deck until it rests on the ground. On units so equipped, lower the front step.
- B. Lift up on the latch plate to release the release handle rod. Push down on the release handle until deck hooks lock into place.
- C. Re-install the Engine to Deck Drive belt onto ALL of the pulleys, including the clutch. **Insure that the Engine to Deck Drive Belt is properly routed onto all of the pulleys and idlers in the drive train.**
- D. Carefully rotate the Deck Belt Tension Latch to re-tension the Engine to Deck Drive Belt.

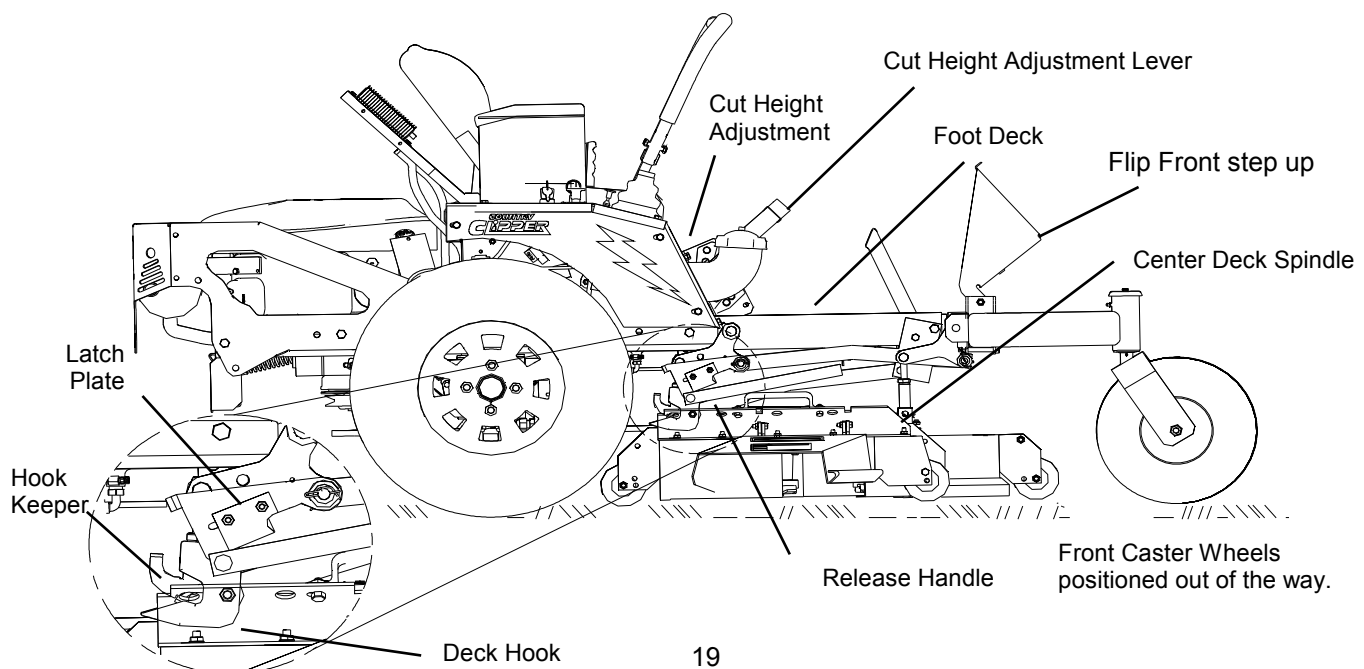

**MOWER SHOWN IN SERVICING POSITION.**

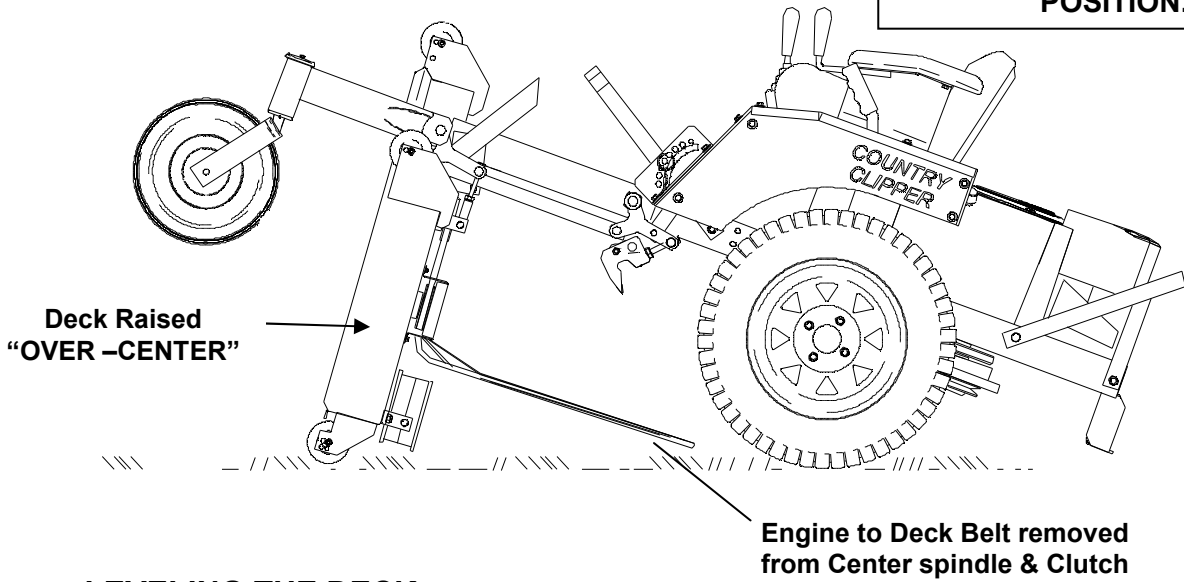

**LEVELING THE DECK**

1. Move the tractor to a hard surface (i.e. concrete or blacktop).
2. Set the tire pressure on each of the four tires to 12 psi
3. Set the deck cutting height to the highest position and rotate the two outside blades by hand until one end of each outside blade points forward (toward the front of tractor)
4. Measure from the ground to the front blade tip of each outside blade. These measurements should be within 1/8" of each other. (NOTE: To simplify this measuring, an optional Blade Measuring tool, part number 629-374A is available from your local "Country Clipper" Dealer)

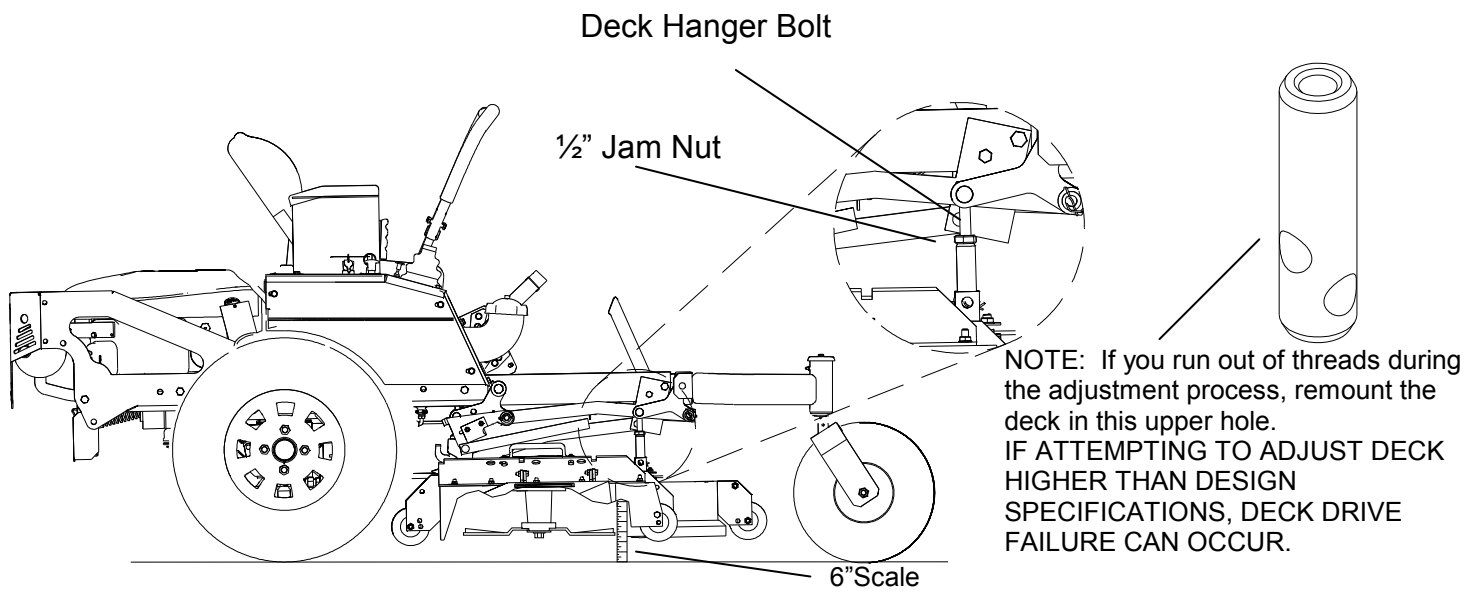

5. If necessary loosen the jam nut(s) of the Deck Hanger Bolt(s) and adjust the Deck Hanger Bolt(s) up or down accordingly. It may be necessary to adjust both the front and rear Deck Hanger Bolts for a given side.

6. Once the side to side cut height is within tolerance, measure from the ground to the blade tip at the rear of each outside blade. This measurement should be between 1/8" and 1/4" higher from the ground than the front of the blade from the ground on the corresponding side of the deck. Adjust rear and/or the front deck hangers accordingly to obtain the proper measurement. Re-measure the side to side cutting height to confirm that they are still within 1/8" of each other at the front of the blade
7. Confirm that the deck is hanging firmly on ALL four deck hanger bolts. Readjust any loose Deck Hanger Bolts accordingly.
8. Once all of the above measurement are confirmed, tighten ALL jam nuts on the Deck Hanger Bolts Failure to tighten can result in an un-level cutting deck and/or lost Deck Hanger Components

## ADJUSTING THE LATCH PLATE

1. Level the deck before proceeding to adjust the latch plate. (Follow instructions on previous page.) Pin the deck in the lowest position before proceeding to adjust the latch plate.
2. Lift up on the hook keeper, while pulling up on the release handle. This will disconnect the rear of the deck.
3. Loosen nuts on the adjustment of the latch plate using a 7/16 wrench. Pull up on the release handle as far as it will allow. Slide adjustment back or forward to where the latch plate will catch the release handle rod at its highest location. Tighten nuts back.
4. Lift up on latch plate and push down on the release handle to lock deck hooks in place.
5. Double check the latch plate adjustment by releasing the deck hangers and pulling up on the release handle. If the latch plate catches the release handle rod, no further adjustment needs to be made. If it does not, follow steps 3-5, as needed.

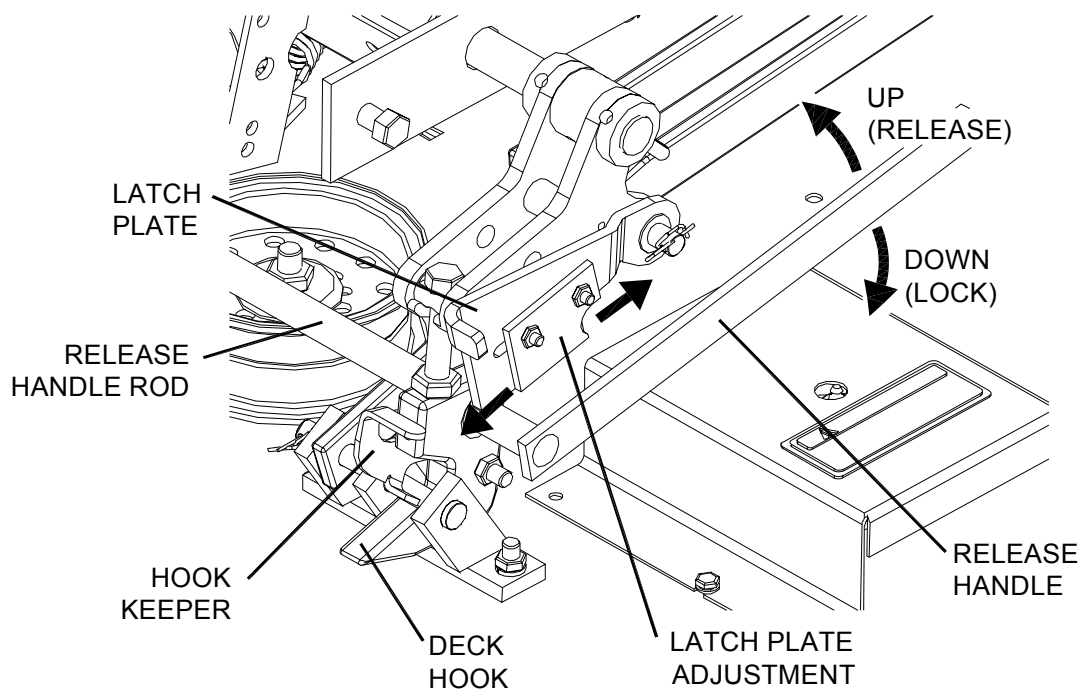

## TROUBLE SHOOTING CHECK LIST

1. ENGINE WON'T TURN OVER:
  - Mower blades engaged ----- disengage blades
  - Drive not in neutral ----- move Control Lever(s) to neutral position
  - Blown fuse ----- replace fuse
  - Dead battery ----- charge or replace
  - Solenoid ----- consult dealer
  - Ignition switch ----- consult dealer
  - Starter ----- consult dealer
  
2. ENGINE WILL TURN OVER BUT WON'T START:
  - No gas ----- refuel  
clean or replace fuel filters
  - Over or under choked ----- adjust choke
  - Spark plug not firing ----- check spark plug  
condition and reset gap\*
  - Carburetor maladjustment ----- reset carburetor adjustment\*
  - Ignition switch ----- consult dealer
  
3. HARD TO START ENGINE:
  - Fuel line clogged ----- clean fuel line and check fuel filter
  - Faulty fuel pump ----- consult dealer
  - Spark plug wire loose or grounded ----- check spark plug wires
  - Spark plug(s) faulty or improperly gapped ----- check spark plug  
condition and reset gap\*
  - Electronic ignition defective ----- consult dealer
  - Dirty or maladjusted carburetor ----- readjust carburetor\*  
consult dealer for carburetor service
  
4. ENGINE STARTS BUT CUTS OUT:
  - Water in gasoline ----- drain old gasoline and replace with new gasoline  
clean carburetor bowl
  - Clogged fuel line ----- check fuel filter  
clean fuel line
  - Vent in fuel cap plugged ----- check vent
  - Faulty fuel pump ----- consult dealer
  - Maladjusted carburetor ----- readjust carburetor\*
  - Engine dies when Control Lever(s) is move from "neutral" ----- parking brake set  
release brake
  
5. ENGINE KNOCKS:
  - Low oil level ----- check and add oil
  - Ignition timing off ----- consult dealer
  - Fuel octane too low ----- drain and replace with  
higher octane gasoline
  - Over heated engine ----- shut off engine and allow to cool

\* See engine manual for engine adjustments.

- 6. ENGINE SOMETIMES SKIPS AT HIGHER SPEEDS:**  
 Incorrect Ignition Timing ----- consult dealer  
 Carburetor maladjusted ----- readjust carburetor  
 Faulty spark plugs ----- check spark plug  
 condition and reset gap\*  
 Bouncing off seat safety switch ----- slow down on rough terrain
- 7. ENGINE OVER HEATED:**  
 Air intake screen or fins clogged ----- clean intake screen and fins  
 Fuel mixture too lean ----- readjust carburetor\*  
 Oil level too low or too high ----- adjust oil level  
 Improper ignition timing ----- consult dealer  
 Running engine too slow ----- run engine faster  
 (NOTE: Always mow at full throttle setting.)
- 8. ENGINE IDLES POORLY:**  
 Carburetor maladjustment ----- readjust carburetor  
 Improper spark plug gap ----- check and re-gap plug\*
- 9. ENGINE BACKFIRES:**  
 Carburetor maladjustment ----- readjust carburetor\*
- 10. ENGINE RUNS BUT MOWER WON'T MOVE FORWARD:**  
 Transmission locks in free wheel position ----- put in lock position (see pg. 10)  
 Drive belt broken or slipping ----- replace drive belt  
 Shift linkage disconnected ----- reconnect  
 Transmission oil low ----- consult dealer  
 Bad transmission ----- consult dealer
- 11. MOWER LOSES POWER OR TRANSMISSIONS OVER HEATS:**  
 Transmission damage ----- consult dealer
- 12. ENGINE STALLS WHEN BLADES ARE ENGAGED:**  
 Operator not on seat ----- sit on seat  
 Faulty interlock system ----- consult dealer  
 Bad blade spindle bearing ----- consult dealer  
 Deck drive belt not properly routed ----- reroute  
 Blades blocked by foreign material ----- clean under deck

- See engine manual for engine adjustments.

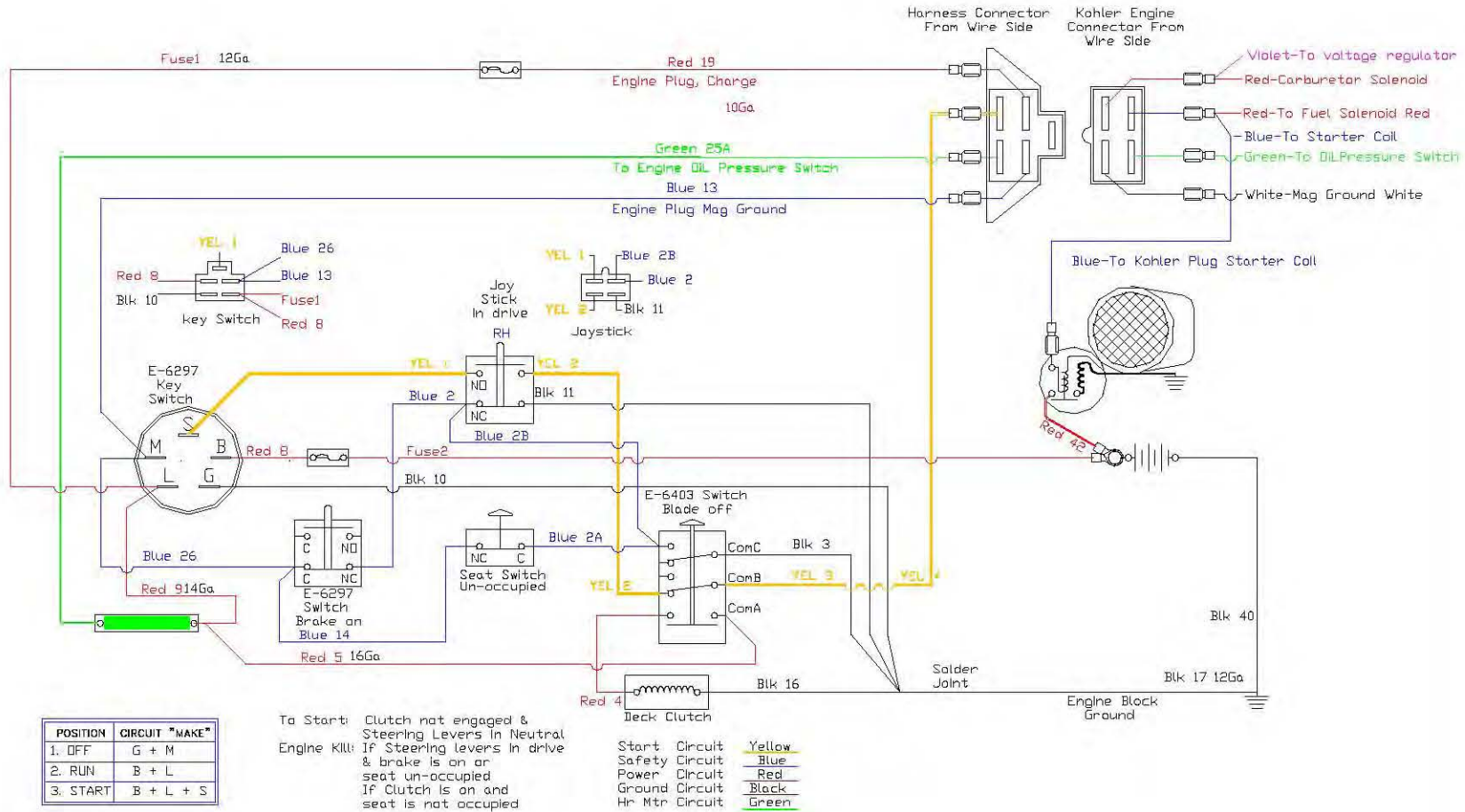



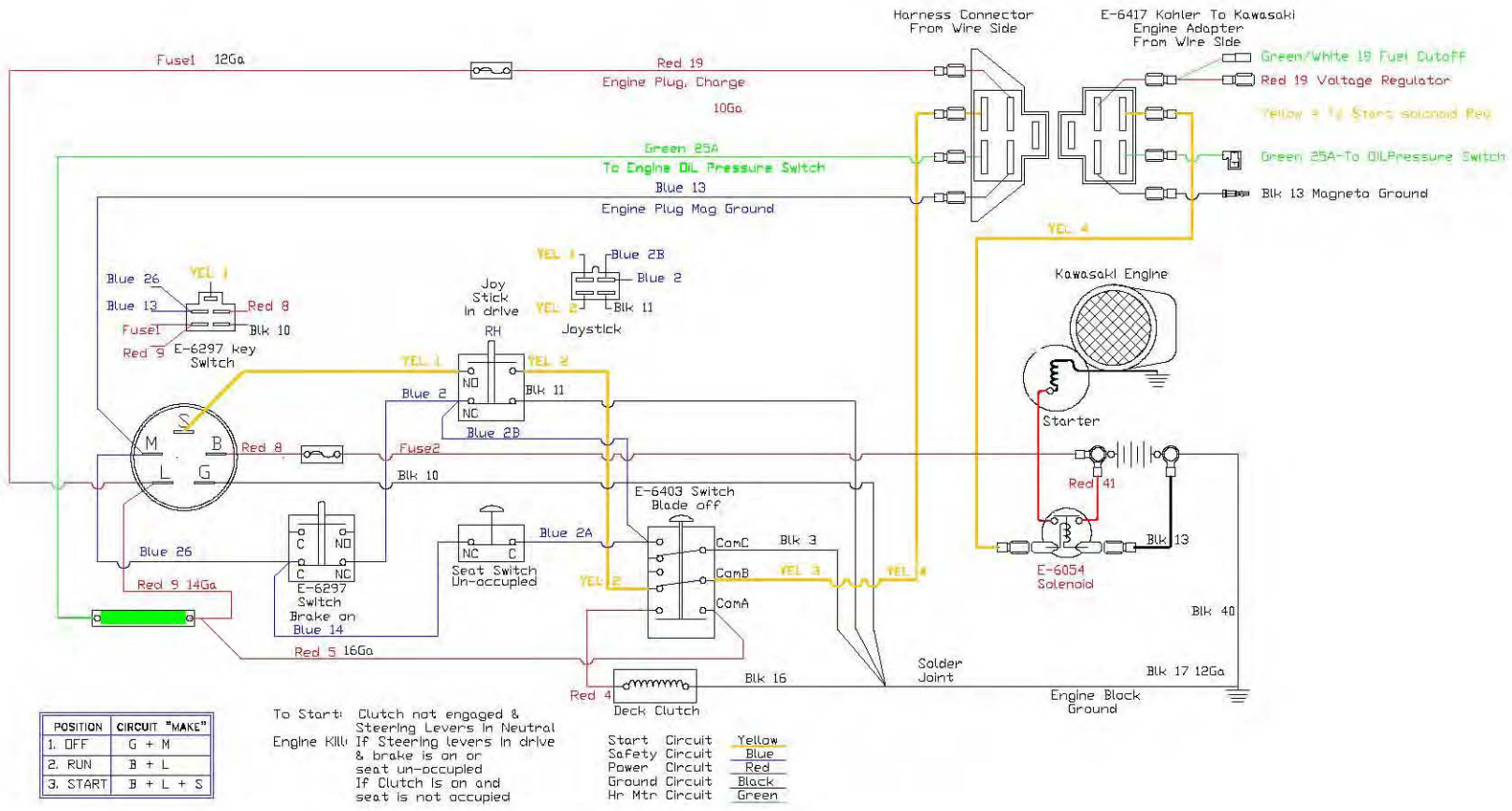

**WIRING SCHEMATIC FOR KAWASAKI JOYSTICK (E-6415) ADAPTER**

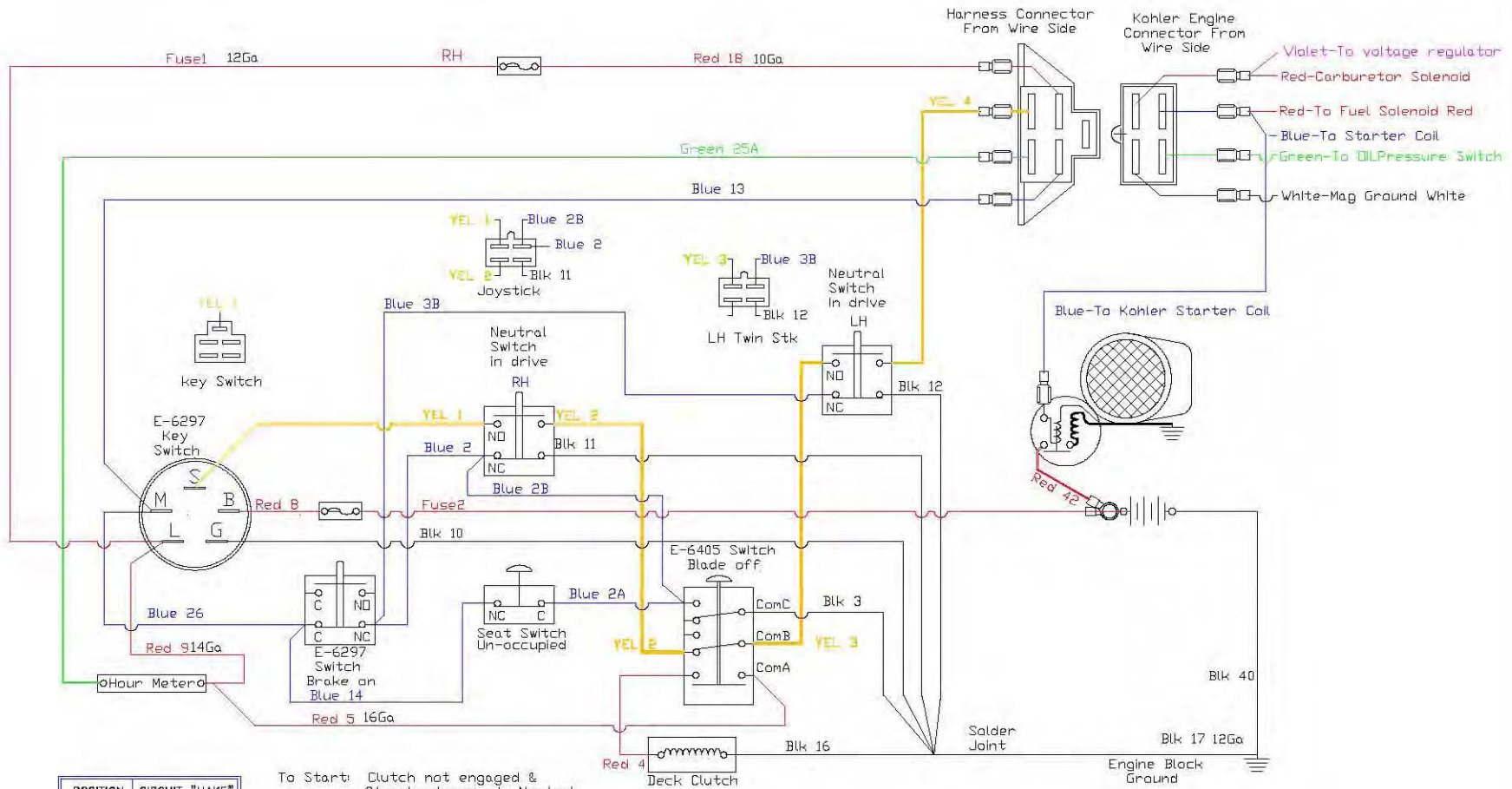

POSITION	CIRCUIT "MAKE"
1. OFF	G + M
2. RUN	B + L
3. START	B + L + S

To Start: Clutch not engaged & Steering Levers in Neutral  
 Engine Kill: If Steering levers in drive & brake is on or seat un-occupied  
 If Clutch is on and seat is not occupied

Start Circuit Yellow  
 Safety Circuit Blue  
 Power Circuit Red  
 Ground Circuit Black  
 Hr Mtr Circuit Green

WIRING SCHEMATIC FOR KOHLER TWINSTICK (E-6416)

**WIRING SCHEMATIC FOR KAWASAKI TWINSTICK (E-6416)  
PLUS (E-6417) ADAPTER**

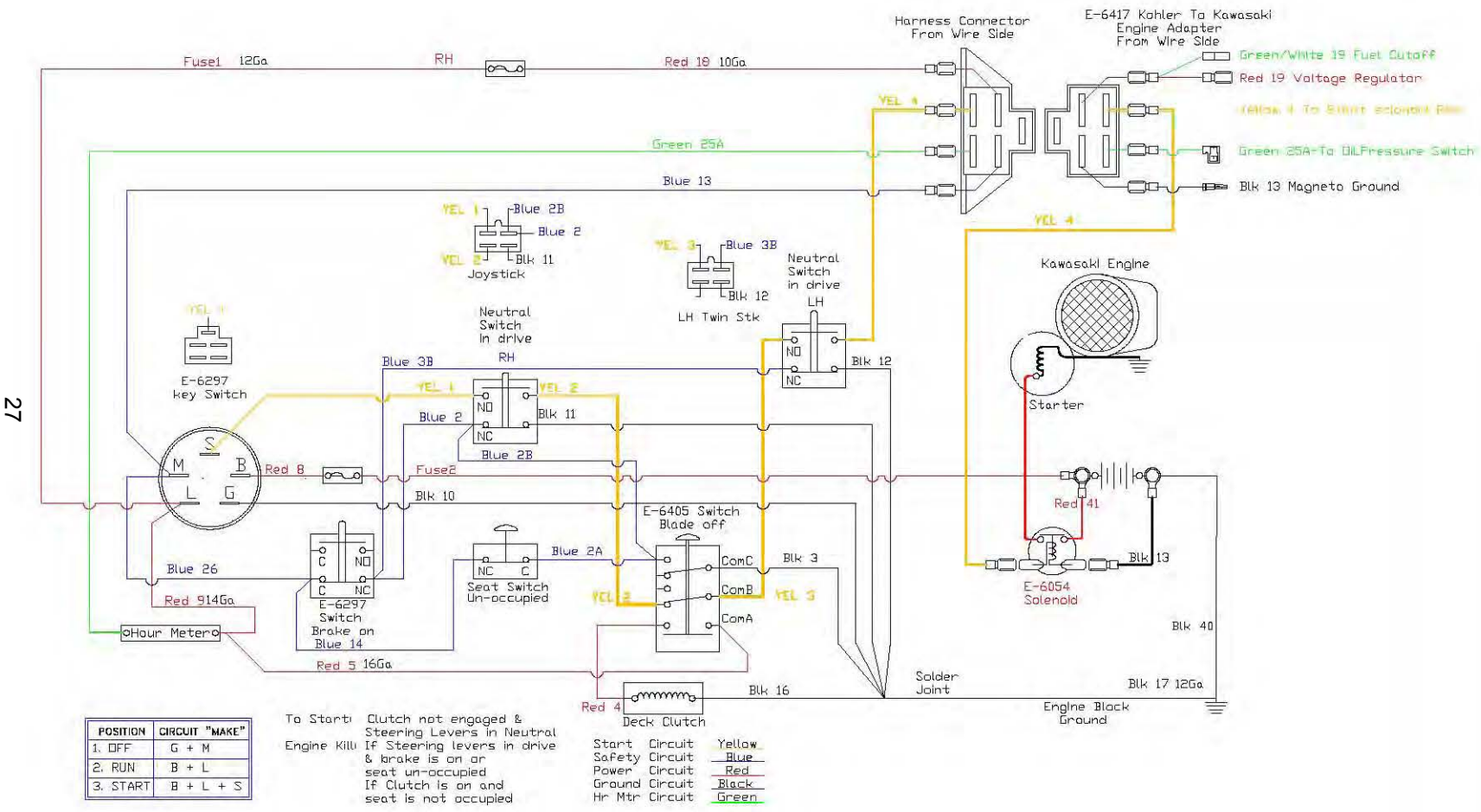

# HYDRAULIC SCHEMATIC:

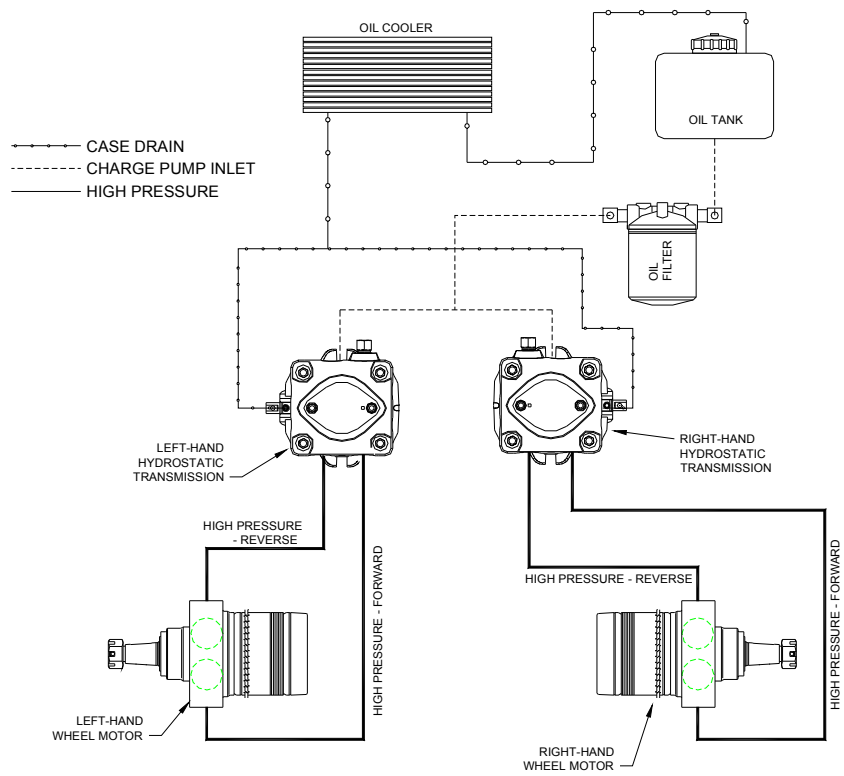

# NOTES / SERVICE RECORDS:

DATE	SERVICE WORK COMPLETED

# Safety Instructions & Operators Manual

# **COUNTRY CLIPPER<sup>®</sup>**



# SR1010



## **WARNING**



The engine exhaust from this product contains chemicals known to the State of California to cause cancer, birth defects, or other reproductive harm.

**Country Clipper Division**  
Shivvers Manufacturing Inc.  
613 W. English St.  
Corydon, IA 50060-0467  
Ph. 641-872-2544 \*\* Fax. 641-872-1593