

REPAIR PARTS MANUAL
FOR
COUNTRY
CLIPPER[®]

THE BOSS[™]

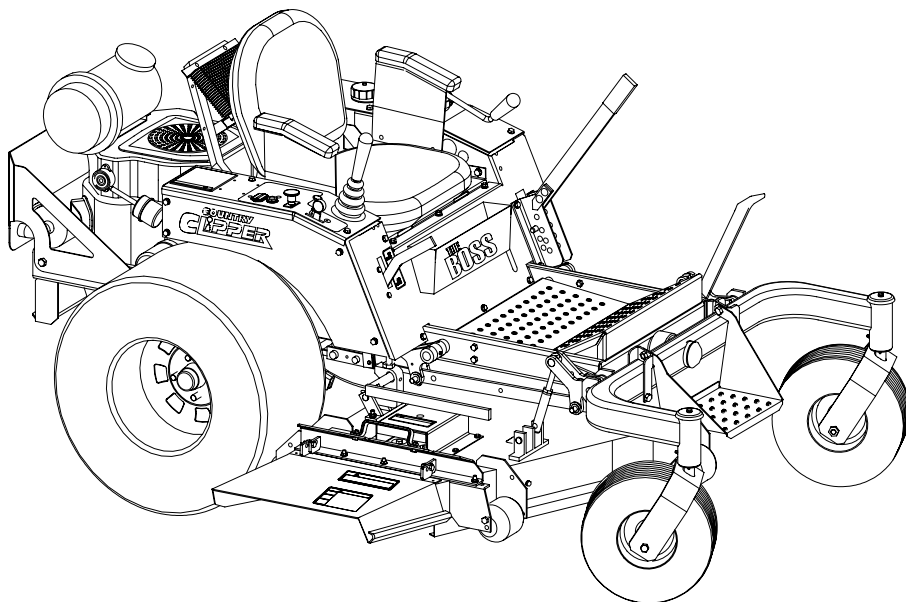

COUNTRY CLIPPER "THE BOSS" SR1205 (2008) ZERO TURN RADIUS MOWER

TABLE OF CONTENTS

PAGE.... CONTENTS

SECTION 1 – MOWER DECKS AND RELATED PARTS

- 1 52" DECK ASSEMBLY
- 2 60" DECK ASSEMBLY
- 3 72" DECK ASSEMBLY
- 4 DECK SPINDLE ASSEMBLY
- 5 SINGLE IDLER & RELATED PARTS
- 6 LIFT HANDLE ASSEMBLY & RELATED PARTS
- 7 QRS. SYSTEM PARTS

SECTION 2 –TRACTOR FRAME AND RELATED PARTS

- 8 LIFT ASSEMBLY & RELATED PARTS
- 9 LIFT ASSEMBLY AND RELATED PARTS (72" BOSS)
- 10 STEP & RELATED PARTS
- 11 DOUBLE IDLER & RELATED PARTS
- 12 ANTI-ROTATING CASTER WHEEL ASSEMBLY
- 13 CASTER WHEEL ASSEMBLY
- 14 FRAME SIDES & RELATED PARTS
- 15 FENDER ASSEMBLY
- 16 SEAT, FOOT DECK & RELATED PARTS

SECTION 3 –TRACTOR DRIVE AND RELATED PARTS

- 17 FUEL INJECTION LINE ASSEMBLY
- 18 FUEL TANK ASSEMBLY
- 19 JACK ASSEMBLY
- 20 JOYSTICK STEERING CONTROL & RELATED PARTS
- 21 JOYSTICK STEERING CONTROL & RELATED PARTS SR-1205
- 22 RIGHT HAND STEERING CONTROL & RELATED PARTS
- 23 LEFT HAND STEERING CONTROL & RELATED PARTS
- 24 PARKING BRAKE ASSEMBLY & RELATED PARTS
- 25 GEAR MOTOR WHEEL ASSEMBLY
- 26 HIGH PRESSURE LINES AND FITTINGS FOR 52" BOSS
- 27 HIGH PRESSURE LINES AND FITTINGS FOR 60" & 72" BOSS
- 28 HIGH PRESSURE LINES BEFORE SERIAL NO. XXXXXX
- 29 MOTOR ASSEMBLY & RELATED PARTS
- 30 ENGINE AND CLUTCH MOUNTING HARDWARE
- 31 MOTOR TO PUMP SINGLE IDLER
- 32 BATTERY BOX & RELATED PARTS
- 33 OIL RETURN LINES & COOLER ASSEMBLY
- 34 WIRE HARNESS & RELATED PARTS

52" DECK ASSEMBLY

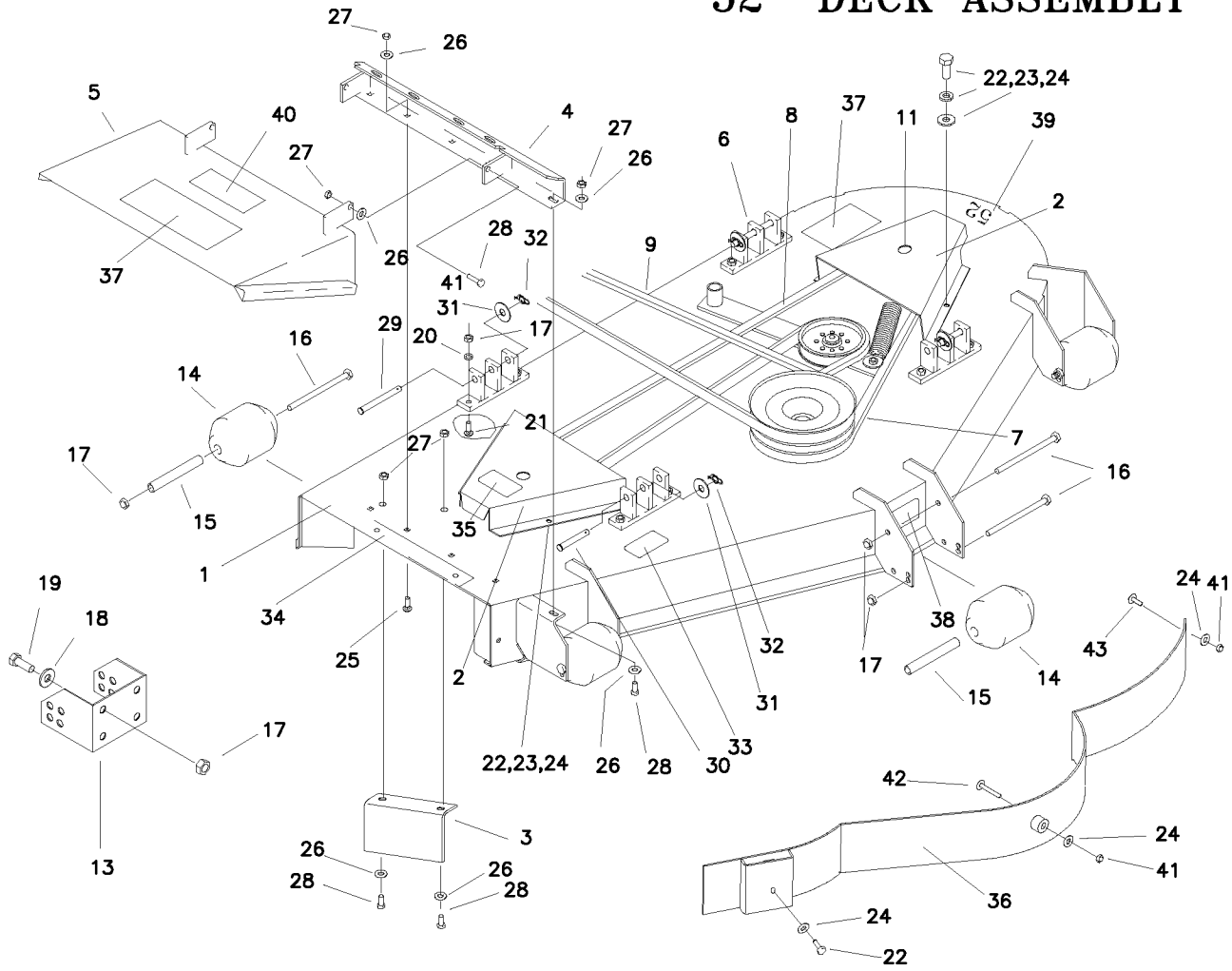

REF NO.	PART NO.	QTY.	DESCRIPTION	REF NO.	PART NO.	QTY.	DESCRIPTION
1	643-084A	1	52" DECK W/DECALS	24	F-1009-01	7	1/4" FLAT WASHER
2	643-083A	2	PULLEY COVER W/DECAL	25	F-1671	4	CARRIAGE BOLT 5/16 X 3/4
3	643-042P	1	AIR BAFFLE	26	F-1009-02	9	5/16" FLAT WASHER
4	637-053W	1	OUTLET STIFFENER	27	F-1125	9	5/16-18 LOCKNUT
5	637-062A	1	60" DECK CHUTE W/DECAL	28	F-1015-15	5	5/16-18 X 1" GR. 5
6	643-016W	4	DECK HANGER	29	H-2240	2	PIN, 1/2" X 4-1/2"
7	D-3808	1	PULLEY, DOUBLE "B" GROOVE	30	F-1816	2	PIN, 1/2" X 2-1/2"
8	D-3807	1	V-BELT, B-114	31	F-1521	4	1/2" FLAT WASHER
9	D-3809	1	V-BELT, B-120	32	H-2239	4	RUE RING 1/2"
10	-----	1	SINGLE IDLER ASS'Y , SEE PG. 5	33	P-10947	1	DECAL, "GREASE SPINDLE"
11	-----	1	SPINDLE ASSEMBLY, SEE PG. 4	34	P-10122	1	DECAL, "MISSING CHUTE"
13	609-182P	2	REAR SCALPER BRACKET	35	P-10935	2	DECAL, "ROTATING..."
14	H-1948	5	ROLLER, 3-3/4 DIA. X 4-13/16	36	643-047W	1	DUST BAFFLE WLDT. 52"
15	609-183P	5	WHEEL BUSHING	37	P-10941	2	DECAL, "MULTI PERIL"
16	F-1741	6	3/8-16 X 6" GR. 5	38	P-11413	1	DECAL, "HOIST POINT"
17	F-1005-03	21	3/8 LOCKNUTSTOVER	39	P-11951	1	DECAL, 52"
18	F-1009-03	8	3/8 FLAT WASHER	40	P-10937	1	DECAL, "WARNING"
19	F-1558	8	3/8-16 X 7/8 GR. 5	41	F-1158	2	LOCKNUT, 1/4-20
20	F-1019-03	8	3/8" LOCKWASHER	42	F-1935	1	1/4-20 X 1 1/2" CARRIAGE BOLT
21	F-1672	8	CARRIAGE BOLT, 3/8 X 1-1/4	43	F-1823	1	1/4-20 X 3/4 CARRIAGE BOLT
22	F-1538	5	1/4-20 X 3/4 GR. 5				
23	F-1019-01	4	1/4" LOCKWASHER				

60" DECK ASSEMBLY

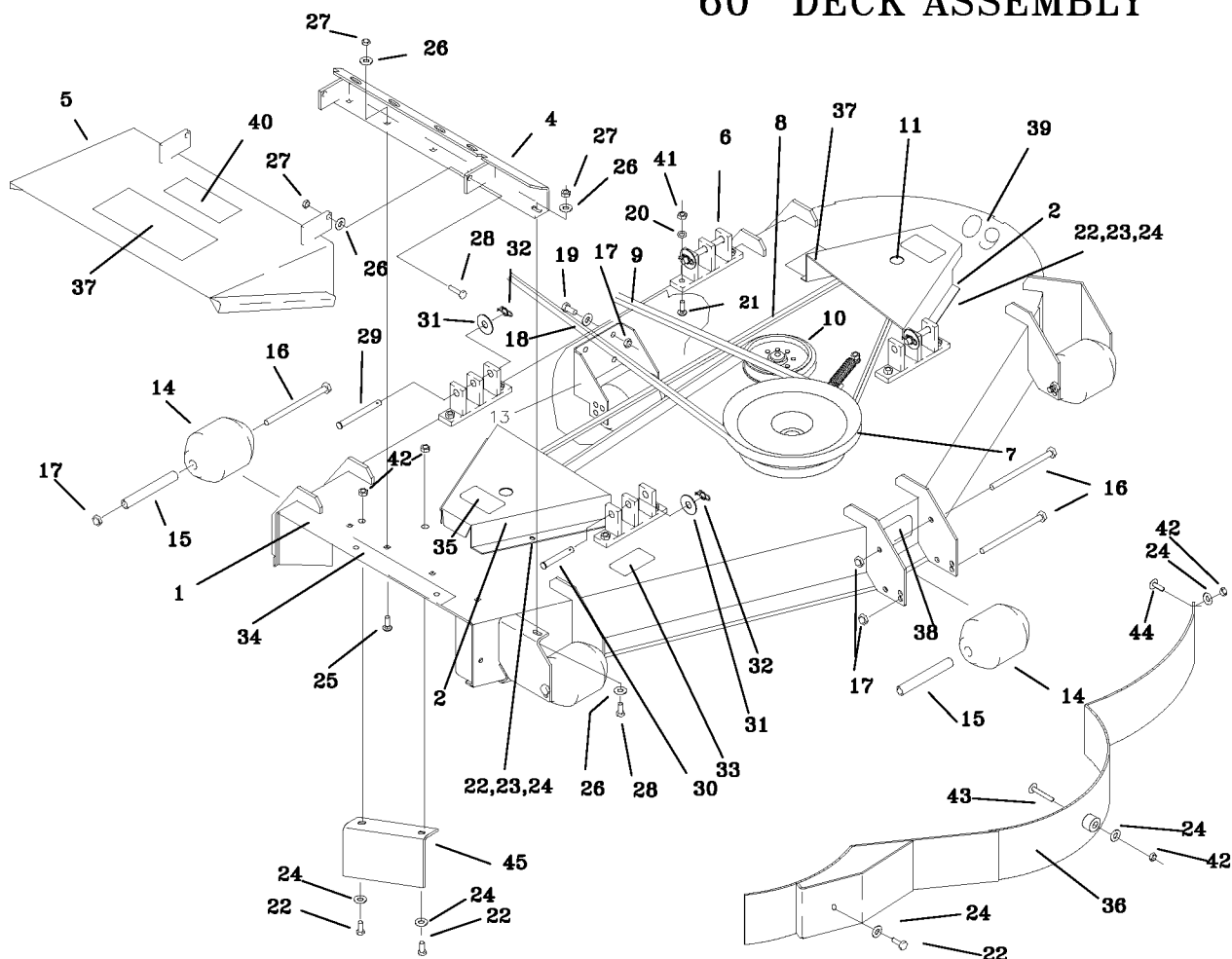

REF NO.	PART NO.	QTY.	DESCRIPTION	REF NO.	PART NO.	QTY.	DESCRIPTION
1	643-081A	1	60" DECK W/DECALS	24	F-1009-01	9	1/4" FLAT WASHER
2	643-083A	2	PULLEY COVER W/DECAL	25	F-1671	4	CARRIAGE BOLT 5/16 X 3/4
3				26	F-1009-02	8	5/16" FLAT WASHER
4	637-053W	1	OUTLET STIFFENER	27	F-1125	7	5/16-18 LOCKNUT
5	637-062A	1	60" DECK CHUTE W/DECAL	28	F-1015-15	3	5/16-18 X 1" GR. 5
6	643-016W	4	DECK HANGER	29	H-2240	2	PIN, 1/2" X 4-1/2"
7	D-3802	1	PULLEY, DOUBLE "B" GROOVE SMALL	30	F-1816	2	PIN, 1/2" X 2-1/2"
8	D-3796	1	V-BELT, B-124	31	F-1521	4	1/2" FLAT WASHER
9	D-3809	1	V-BELT, B-120	32	H-2239	4	RUE RING 1/2"
10	-----	1	SINGLE IDLER ASSEMBLY, SEE PG. 5	33	P-10947	1	DECAL, "GREASE SPINDLE"
11	-----	1	SPINDLE ASSEMBLY, SEE PG. 4	34	P-10122	1	DECAL, "MISSING CHUTE"
12				35	P-10935	2	DECAL, "ROTATING..."
13	609-182P	2	REAR SCALPER BRACKET	36	643-047W	1	DUST BAFFLE WLDT. 60"
14	H-1948	6	ROLLER, 3-3/4 DIA. X 4-13/16	37	P-10941	2	DECAL, "MULTI PERIL"
15	609-183P	6	WHEEL BUSHING	38	P-11413	1	DECAL, "HOIST POINT"
16	F-1741	7	3/8-16 X 6" GR. 5	39	P-11952	1	DECAL, 60"
17	F-1239	15	3/8 LOCKNUT	40	P-10937	1	DECAL, "WARNING"
18	F-1009-03	8	3/8 FLAT WASHER	41	F-1005-03	8	LOCKNUT, 3/8 STOVER
19	F-1558	8	3/8-16 X 7/8 GR. 5	42	F-1158	4	LOCKNUT, 1/4-20
20	F-1019-03	8	3/8" LOCKWASHER	43	F-1935	1	1/4-20 X 1 1/2" CARRIAGE BOLT
21	F-1672	8	CARRIAGE BOLT, 3/8 X 1-1/4	44	F-1823	1	1/4-20 X 3/4 CARRIAGE BOLT
22	F-1538	7	1/4-20 X 3/4 GR. 5	45	643-042P	1	AIR BAFFLE
23	F-1019-01	4	1/4" LOCKWASHER				

72" DECK ASSEMBLY

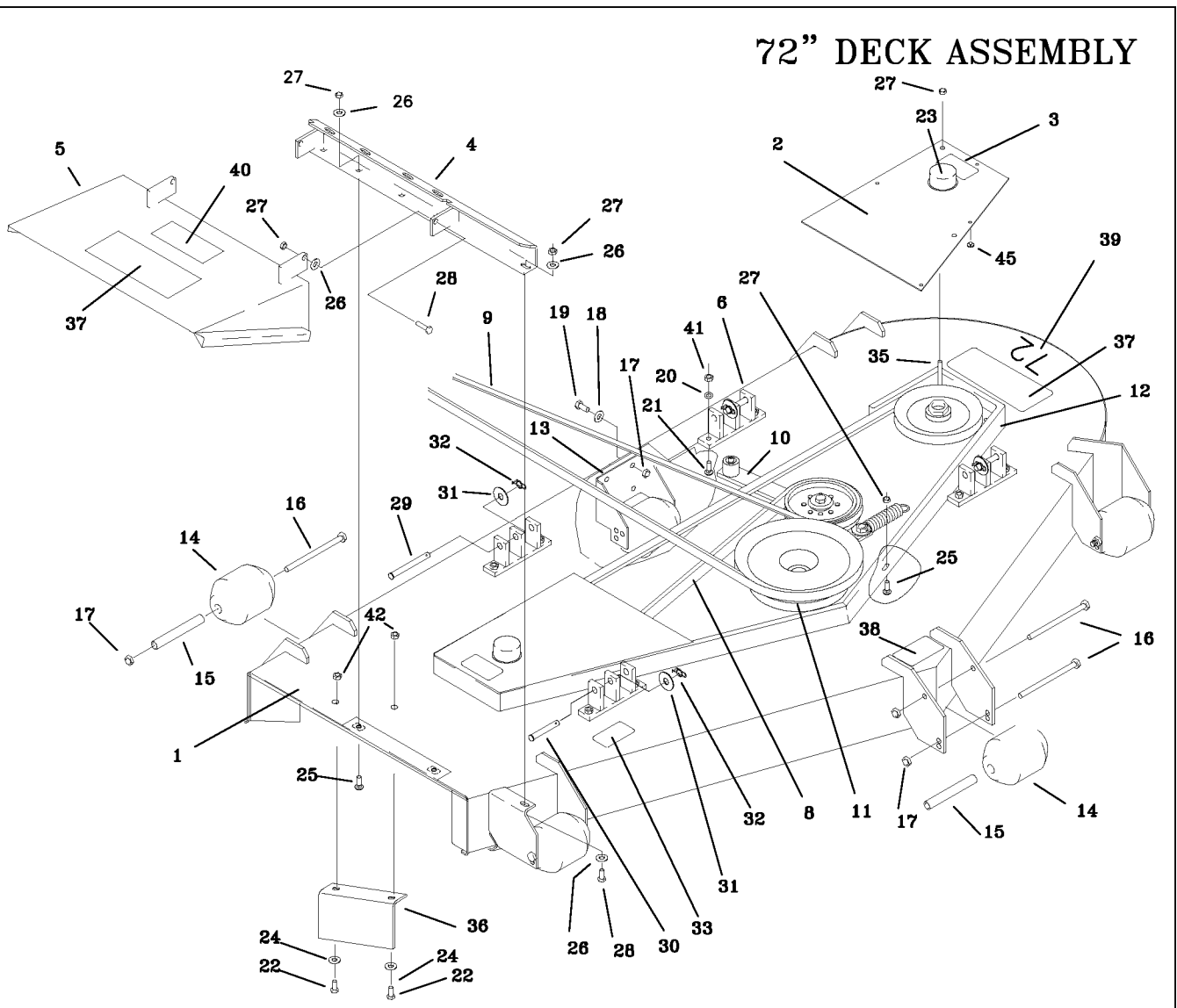

REF NO.	PART NO.	QTY.	DESCRIPTION	REF NO.	PART NO.	QTY.	DESCRIPTION
1	643-082A	1	72" DECK W/DECALS	24	F-1009-01	5	1/4" FLAT WASHER
2	643-070A	2	PULLEY COVER, W/DECAL	25	F-1671	21	CARRIAGE BOLT 5/16 X 3/4
3	P-10935	2	DECAL, "ROTATING..."	26	F-1009-02	6	5/16" FLAT WASHER
4	643-051W	1	OUTLET STIFFENER	27	F-1125	29	5/16-18 LOCKNUT
5	643-071A	1	72" DECK CHUTE W/DECAL	28	F-1015-15	4	5/16-18 X 1" GR. 5
6	643-016W	4	DECK HANGER	29	H-2240	2	PIN, 1/2" X 4-1/2"
8	D-3797	1	V-BELT, B-142	30	F-1816	2	PIN, 1/2" X 2-1/2"
9	D-3796	1	V-BELT, MOTOR TO DECK, B-124	31	F-1521	4	1/2" FLAT WASHER
10	-----	1	SINGLE IDLER ASSEMBLY, SEE PG. 5	32	H-2239	4	RUE RING 1/2"
11	-----	1	SPINDLE ASSEMBLY, SEE PG. 4	33	P-10947	1	DECAL, "GREASE SPINDLE"
12	643-068P	1	TOP STIFFENER, 72"	34	P-10122	1	DECAL, "MISSING CHUTE"
13	609-182P	1	REAR SCALPER BRACKET	35	F-1707	4	CARRIAGE BOLT, 5/16 X 2 1/4"
14	H-1948	6	ROLLER, 3-3/4 DIA. X 4-13/16	36	643-042P	1	AIR BAFFLE
15	609-183P	6	WHEEL BUSHING	37	P-10941	2	DECAL, "MULTI PERIL"
16	F-1741	7	3/8-16 X 6" GR. 5	38	P-11413	1	DECAL, "HOIST POINT"
17	F-1239	11	3/8 LOCKNUT	39	P-11953	1	DECAL 72"
18	F-1009-03	4	3/8 FLAT WASHER	40	P-10937	1	DECAL, "WARNING"
19	F-1558	4	3/8-16 X 7/8 GR. 5	41	F-1005-03	8	LOCKNUT, 3/8 STOVER
20	F-1019-03	8	3/8" LOCKWASHER	42	F-1158	4	LOCKNUT, 1/4-20
21	F-1672	8	CARRIAGE BOLT, 3/8 X 1-1/4	43	F-1935	1	1/4-20 X 1 1/2" CARRIAGE BOLT
22	F-1538	3	1/4-20 X 3/4 GR. 5	44	F-1823	1	1/4-20 X 3/4 CARRIAGE BOLT
23	H-1798	2	GALVANIZED CAP	45	H-2461	8	RUBBER BUMPER

DECK SPINDLE ASSEMBLY

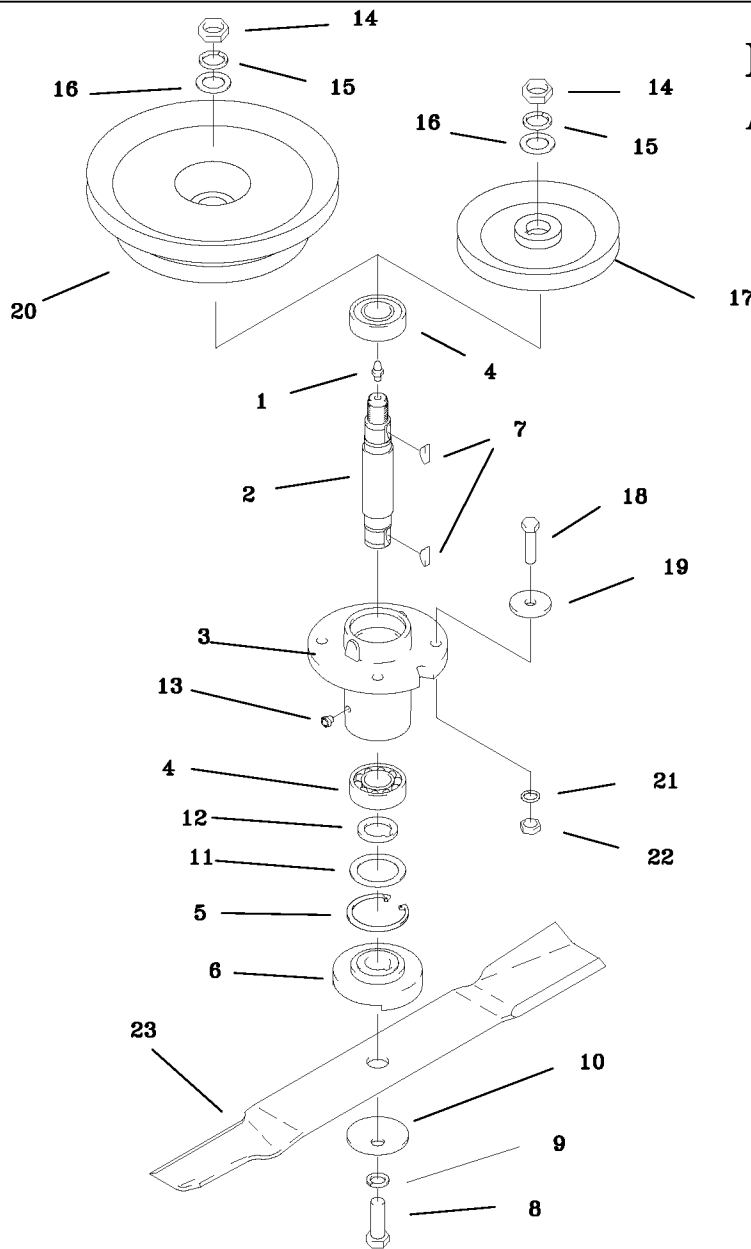

REF NO.	PART NO.	QTY.	DESCRIPTION	REF NO.	PART NO.	QTY.	DESCRIPTION
-	660-045A	-	SPINDLE ASSEMBLY	18	F-1572	4	3/8-24 X 1-1/2" HHCS GR. 5
1	H-1056	1	GREASE FITTING	19	609-034P	4	SPINDLE SPACER REINFORCEMENT
2	609-162P	1	SPINDLE SHAFT	20	D-3802	-	PULLEY, 2 GROOVE 60"
3	609-223P	1	SPINDLE HOUSING	-	D-3801	-	PULLEY, 2 GROOVE 72"
4	D-3058	2	BEARING, #6205-2RS	-	D-3808	-	PULLEY, 2 GROOVE 52"
5	H-1893	1	SNAP RING INT. 52MM	21	F-1019-03	4	3/8" LOCK WASHER
6	609-152P	1	BLADE SPACER	22	F-1573	4	3/8-24 LOCKNUT, M-F
7	D-1004-02	2	KEY, WOODRUF, 1/4 X 3/4	23	H-2499	-	FUSION, HIGH L, 18-3/8" CUT 52"
8	F-1526	1	1/2-13 X 1-1/2" HHCS GR. 5	-	H-2500	-	FUSION, HIGH L, 21" CUT 60"
9	F-1464	1	1/2" LOCK WASHER	-	H-2501	-	FUSION, HIGH L, 25" CUT 72"
10	F-1507	1	WASHER, 1/2" CUPPED	-	H-2387	-	BLADE, LOW L, 18-3/8" CUT 52"
11	609-151P	1	WASHER, SEAL	-	H-1667	-	BLADE, LOW L, 21" CUT 60"
12	609-073P	1	ARBBER SPACER	-	H-2397	-	BLADE, LOW L, 25" CUT 72"
13	H-2066	1	GREASE VENT 5 LBS.	-	H-2246	-	BLADE HIGH L, 18-3/8" CUT 52"
14	F-1461	1	3/4-16 NUT, HEX JAM	-	H-1708	-	BLADE, HIGH L, 21" CUT 60"
15	F-1463	1	3/4" LOCK WASHER	-	H-2459	-	BLADE, HIGH L, 25" CUT 72"
16	F-1510	1	3/4" WASHER, FLAT STD.	-	H-2251	-	BLADE, GATOR 18-3/8" CUT 52"
17	D-3800	-	PULLEY, 1 GROOVE 6 3/16"	-	H-2203	-	BLADE, GATOR 21" CUT 60"

LIFT HANDLE ASSEMBLY & RELATED PARTS

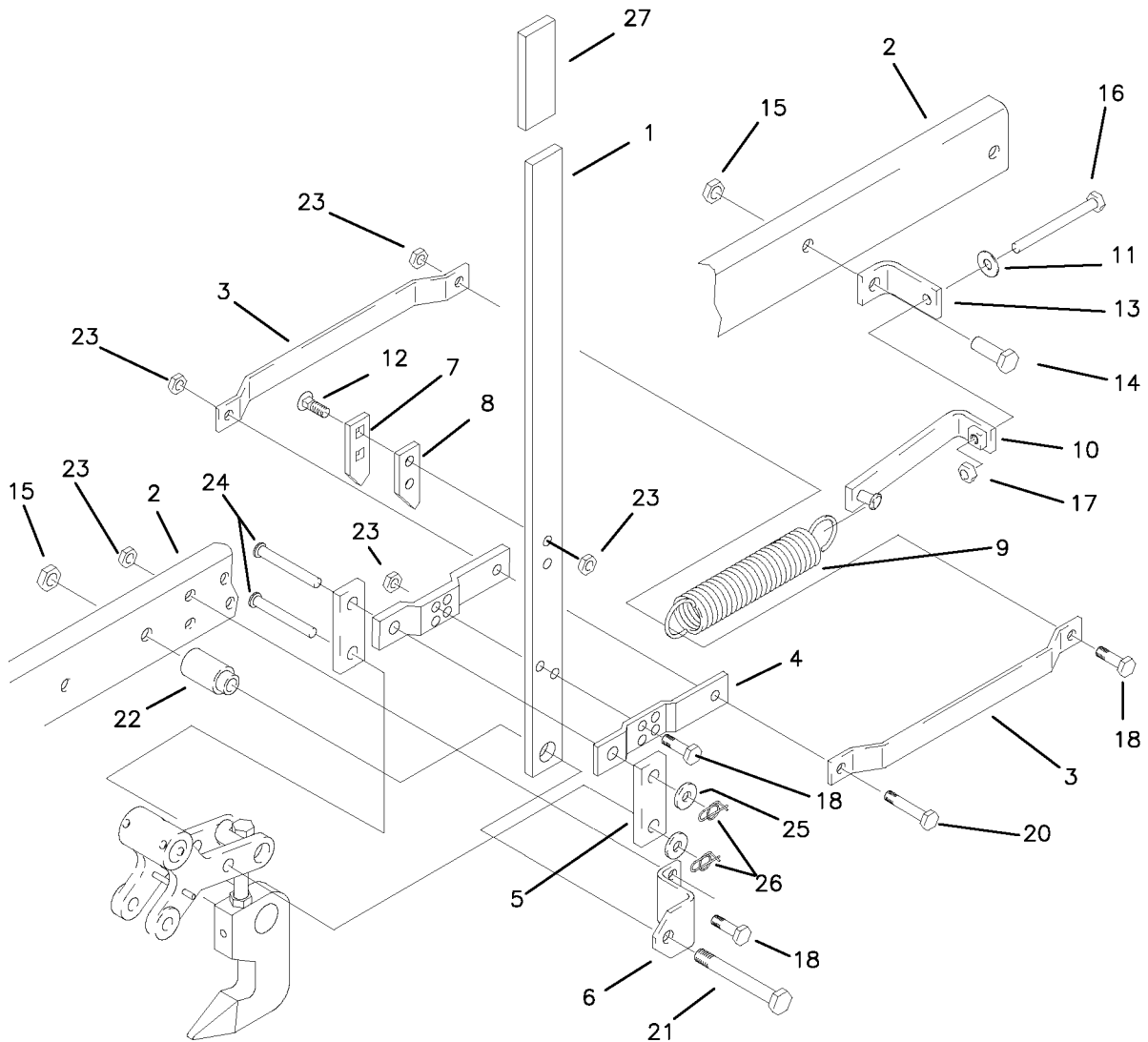

REF NO.	PART NO.	QTY.	DESCRIPTION	REF NO.	PART NO.	QTY.	DESCRIPTION
1	642-062P	1	LIFT HANDLE	14	F-1526	1	3/8-16 X 1-1/2" GR. 5
2	642-040W	1	FRAME WELDMENT, LH.	15	F-1005-05	2	NUT, 1/2-13 LOCKNUT
3	642-055P	2	SPRING EXTENSION	16	F-1646	1	3/8-16 X 5" FULL THREAD
4	642-060P	2	SPRING ANCHOR PLATE	17	F-1011-03	1	HEX NUT, 3/8-16 UNC-2B
5	642-061P	2	HANDLE LINK	18	F-1307	3	3/8-16 X 1-1/4" GR. 5
6	642-041P	1	HANDLE PIVOT BRACKET	19	F-1073	3	3/8-16 X 2" GR. 5
7	642-127P	1	TOP PEG LATCH PLATE	20	F-1015-30	1	3/8-16 X 2 1/2" GR. 5
8	642-126P	1	TOP PEG SPACER PLATE	21	F-1828	1	1/2-13 X 3-1/2" GR. 5
9	H-1610	1	SPRING, 1-1/2" OD. X 8"	22	642-095P	1	HANDLE PIVOT PIN
	H-1868	1	SPRING, HEAVY 8" (72" DECK)	23	F-1005-03	7	NUT, 3/8-16 LOCKNUT (STOVER)
10	620-227W	1	SPRING TIGHTENER WLDT.	24	F-1889	2	CLEVIS PIN, 1/2 X 2-5/8"
11	F-1009-03	1	FLAT WASHER, 3/8"	25	F-1521	2	1/2" FLAT WASHER
12	F-1672	2	3/8-16 X 1-1/4" CARRIAGE BOLT	26	H-2239	2	RUE RING, 1/2"
13	642-071W	1	SPRING ANCHOR WELDMENT	27	H-2324	1	VINYL GRIP, 3/8 X 1-1/2"

QRS SYSTEM PARTS

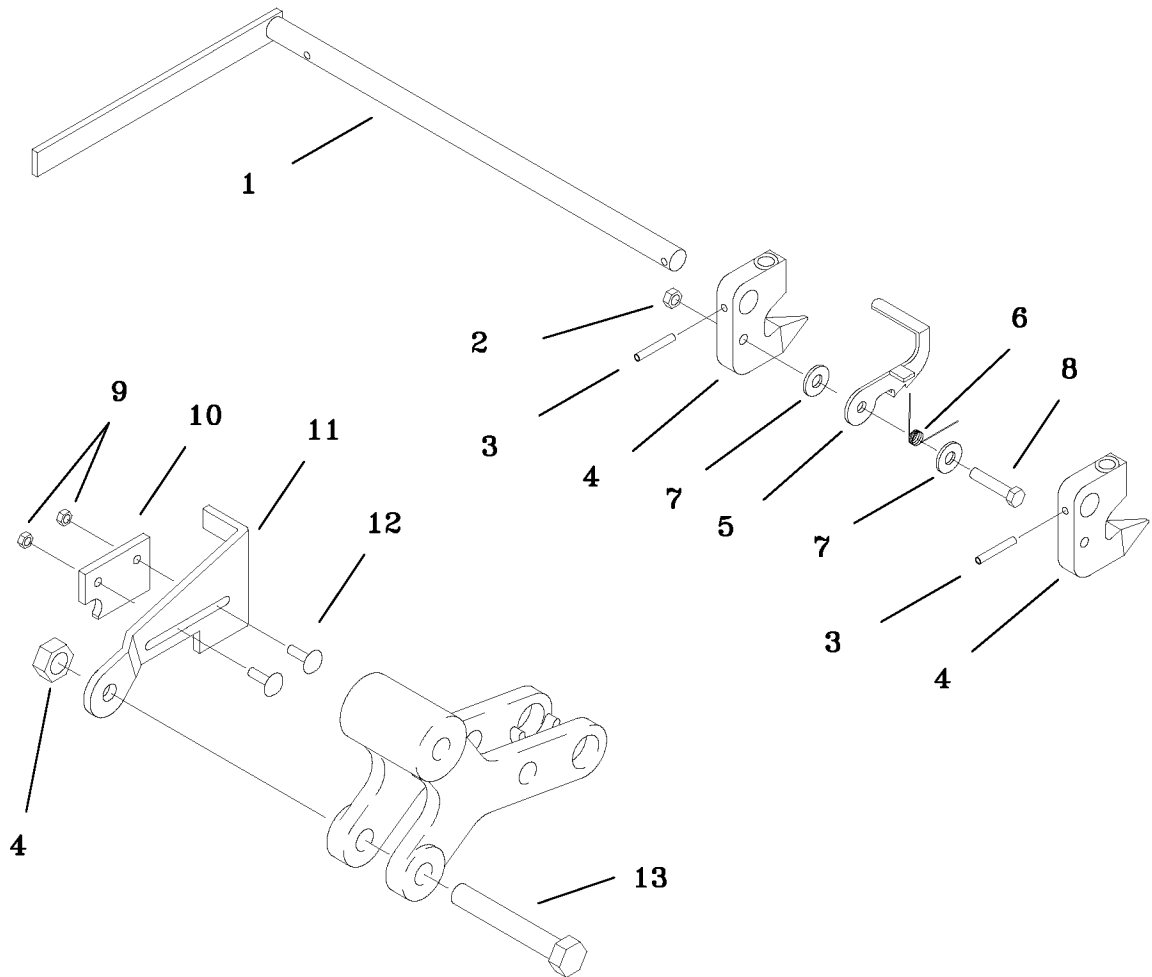

REF NO.	PART NO.	QTY.	DESCRIPTION
1	659-148W	1	RELEASE HANDLE
-	659-163W	1	RELEASE HANDLE FOR 72" BOSS
2	F-1005-03	1	3/8-16 STOVER NUT
3	F-2009	2	ROLL PIN
4	659-140P	2	HOOK
5	659-145P	1	HOOK KEEPER
6	H-2547	1	SPRING
7	F-1009-03	2	3/8" FLAT WASHER
8	F-1073	1	3/8-16 X 2" BOLT
9	F-1158	1	1/4-20 STOVER NUT
10	659-170P	1	CATCH
11	659-146P	1	LATCH PLATE
12	F-1823	1	1/4 X 3/4" CARRIAGE BOLT
13	F-1828	1	1/2-13 X 3-1/2' BOLT

LIFT ASSEMBLY
& RELATED PARTS

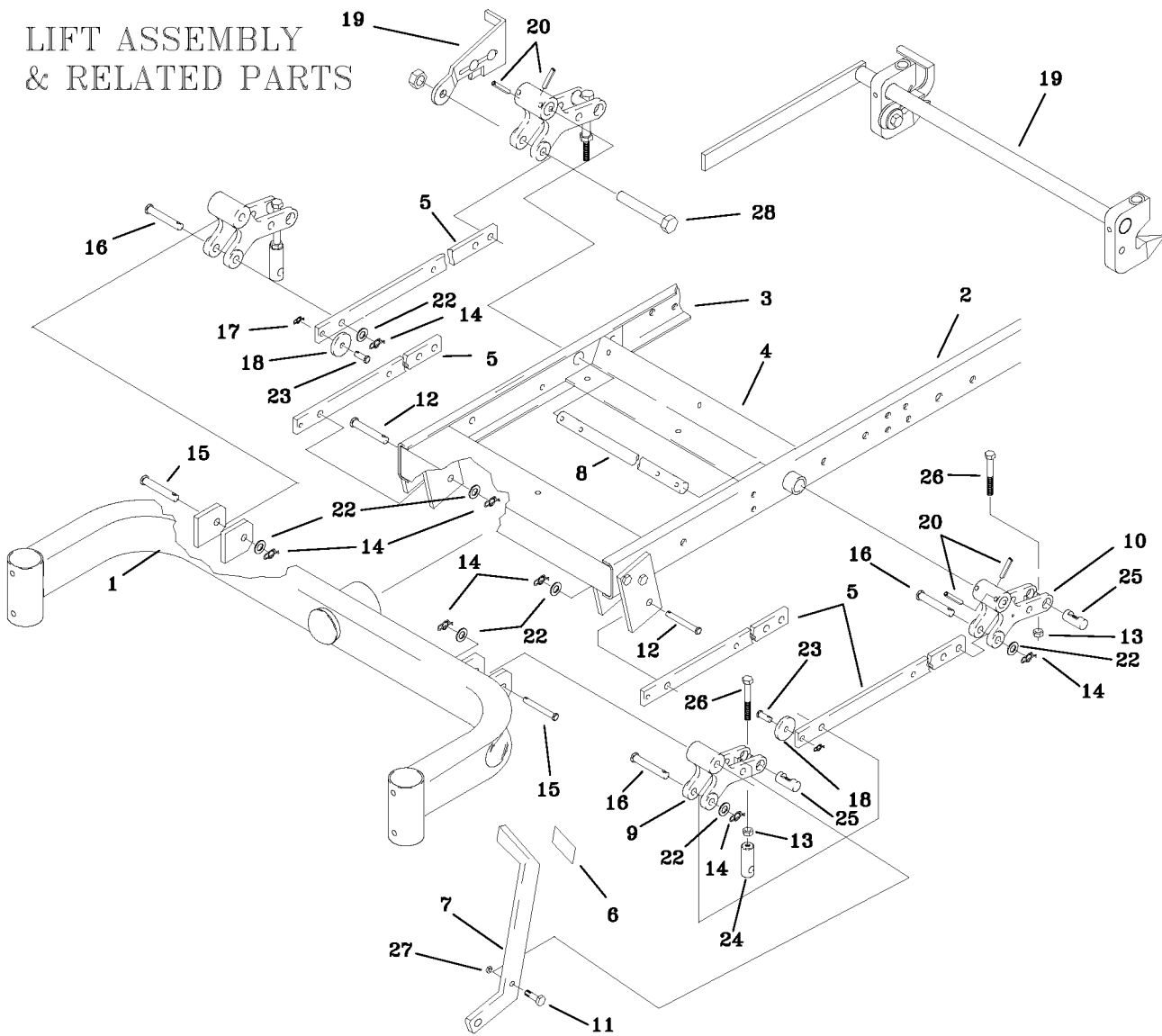

REF NO.	PART NO.	QTY.	DESCRIPTION	REF NO.	PART NO.	QTY.	DESCRIPTION
1	642-185W	1	FRONT AXLE WELDMENT	19	-----	1	QRS SYSTEM, SEE PAGE 7
2	642-040W	1	FRAME WELDMENT, LH	20	F-1036-37	4	ROLL PIN, 5/16 DIA. X 1.750
3	642-039W	1	FRAME WELDMENT, RH	21	-	-	-
4	642-019W	1	FRONT PIVOT CHANNEL	22	F-1521	7	WASHER, 1/2 NARROW
5	642-059P	4	LINK BAR	23	F-1691	2	CLEVIS PIN, 3/8 X 1"
6	H-2401	1	TREAD PAD	24	642-175P	2	ADJUSTABLE HANGER END
7	659-056P	1	DECK LIFT PEDAL	25	642-177P	4	HANGER PIN
8	620-051P	1	LIFT BAR	26	F-1936	4	1/2-13 X 3-1/2, 2" THREAD
9	642-081P	2	LIFT SLEEVE, FRONT	27	F-1125	1	5/16 LOCKNUT
10	642-082P	2	LIFT SLEEVE, REAR	28	F-1828	1	1/2-13 X 3-1/2" BOLT
11	F-1879	1	5/16-18 X 1 1/4", GR.5				
12	F-1896	2	CLEVIS PIN, 1/2 X 1-3/4"				
13	F-1489	4	NUT. 1/2" JAM				
14	H-2239	7	RUE RING, 1/2"				
15	F-1890	2	CLEVIS PIN, 1/2 X 3-1/2"				
16	F-1898	3	CLEVIS PIN, 1/2 X 2-3/4"				
17	F-1492	2	RUE RING, 5/16-3/8 PIN				
18	642-105P	2	ROLLER				

**LIFT ASSEMBLY
& RELATED PARTS
WIDE FRONT END**

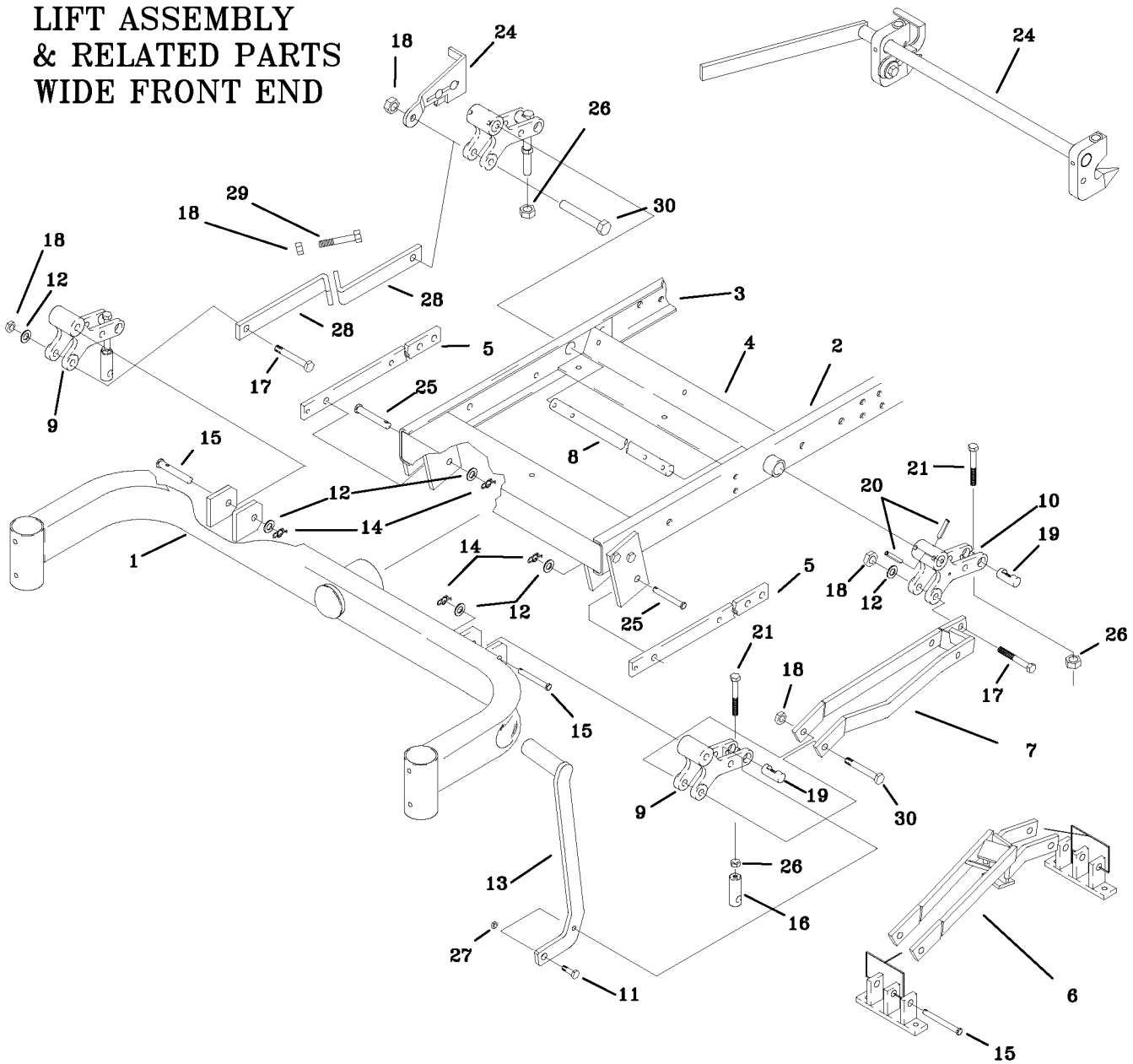

REF NO.	PART NO.	QTY.	DESCRIPTION	REF NO.	PART NO.	QTY.	DESCRIPTION
1	642-186W	1	WIDE FRONT AXLE WELDMENT	18	F-1005-05	5	NUT, 1/2" STOVER
2	647-142W	1	FRAME WELDMENT, LH	19	642-177P	2	HANGER PIN
3	647-143W	1	FRAME WELDMENT, RH	20	F-1036-37	4	ROLL PIN, 5/16 DIA. X 1.750
4	642-019W	1	FRONT PIVOT CHANNEL	21	F-1936	4	1/2-13 X 3-1/2, 2" THREAD
5	642-059P	2	LINK BAR	22	F-1573	2	LOCK NUT 3/8-24
6	629-545W	1	LOWER JACK MNT.	23	F-1572	2	3/8-24 X 1-1/2 HH GR. 5
7	629-540W	1	UPPER JACK MNT.	24	----	1	QRS SYSTEM, SEE PAGE 7
8	620-051P	1	LIFT BAR	25	F-1896	2	CLEVIS PIN, 1/2 X 1-3/4"
9	642-081P	2	LIFT SLEEVE, FRONT	26	F-1489	4	NUT, 1/2" JAM
10	642-082P	2	LIFT SLEEVE, REAR	27	F-1125	1	5/16" LOCKNUT
11	F-1897	1	5/16-18 X 1-1/4" BOLT	28	647-144P	2	OFFSET LINK BAR ADJUSTABLE
12	F-1521	7	WASHER, 1/2 NARROW	29	F-1386	1	1/2-13 X 1-1/4" BOLT
13	629-249W	1	OFFSET DECK LIFT PEDAL	30	F-1828	2	1/2-13 X 3-1/2" BOLT
14	H-2239	3	RUE RING, 1/2"				
15	F-1890	3	CLEVIS PIN, 1/2 X 3-1/2"				
16	642-175P	2	ADJUSTABLE HANGER END				
17	F-1439	3	1/2-13 X 3", GR.5				

STEP & RELATED PARTS

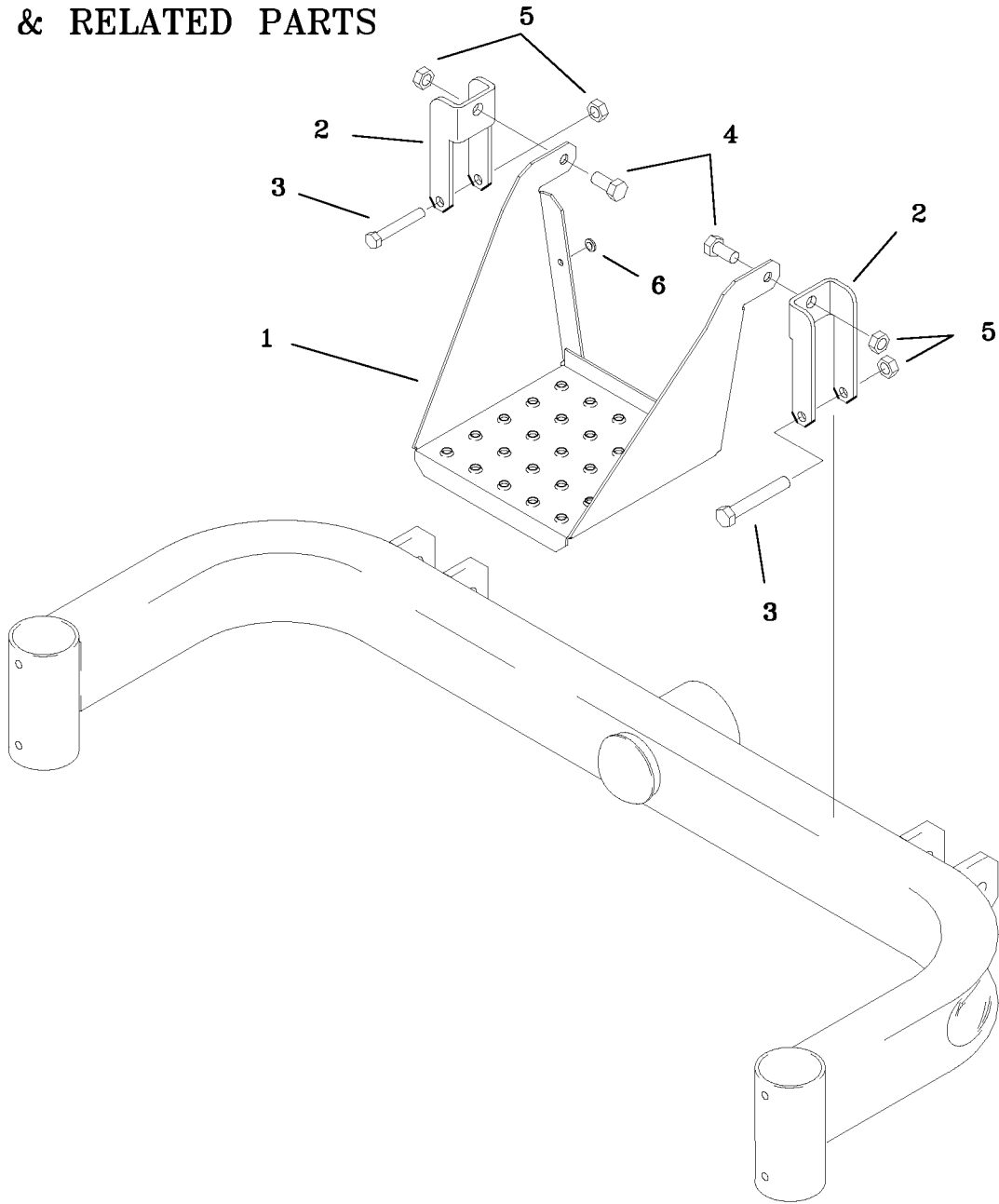

REF NO.	PART NO.	QTY.	DESCRIPTION
1	647-133P	1	STEP
2	647-134P	2	YOKE
3	F-1537	2	3/8-16 X 3" BOLT
4	F-1015-23	2	3/8-16 X 3/4" BOLT
5	F-1005-03	4	3/8-16 STOVER NUT
6	H-2461	2	BUMPER, RUBBER

DOUBLE IDLER & RELATED PARTS

VIEWED FROM RIGHT REAR

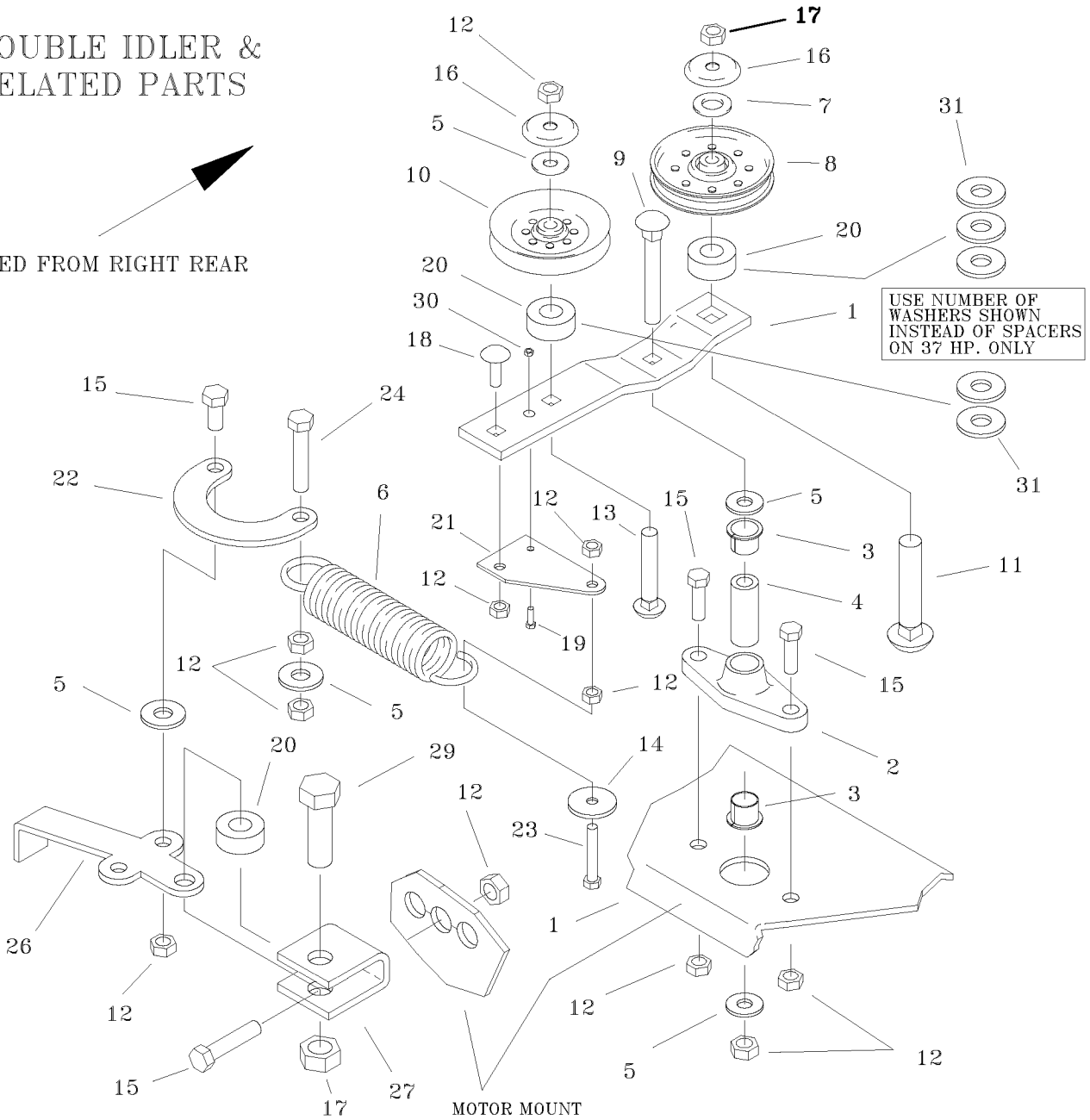

REF NO.	PART NO.	QTY.	DESCRIPTION	REF NO.	PART NO.	QTY.	DESCRIPTION
1	660-036P	1	IDLER ARM	16	620-201P	2	BEARING CAP
2	660-039P	1	DOUBLE IDLER MOUNT	17	F-1005-05	2	1/2" STOVER NUT
3	D-3730	2	BUSHING	18	F-1008-23	1	3/8-16 X 3/4 CARRIAGE BOLT
4	659-085P	1	MOUNTING PIN	19	F-1538	1	1/4 X 3/4 BOLT
5	F-1009-03	8	3/8" FLAT WASHER	20	660-038P	3	3/8" THICK SPACER (NOT ON 37)
6	H-2092	1	SPRING	21	647-193P	1	IDLER EXTENSION
7	F-1521	1	1/2" FLAT WASHER, (NARROW)	22	647-194P	1	BELT TIGHTENER LOOP
8	D-3338	1	IDLER PULLEY	23	F-1073	1	3/8-16 X 2" BOLT
9	F-1865	1	3/8-16 X 2-1/2" CARRIAGE BOLT	24	F-1307	1	3/8-16 X 1-1/4" BOLT
10	D-3758	1	"V" IDLER PULLEY	25	-	-	-
11	F-1822	1	1/2-13 X 2-1/4" CARRIAGE BOLT	26	660-030P	1	HANDLE
12	F-1005-03	10	3/8-16 STOVER NUT	27	661-015P	1	SHACKLE
13	F-1177	1	3/8-16 X 1-1/2" CARRIAGE BOLT	28	-	-	-
14	609-034P	1	SPINDLE SPACER WASHER	29	F-1526	1	1/2-13 X 1-1/2" BOLT
15	F-1394	4	3/8-16 X 1" BOLT	30	F-1158	1	1/4-20 LOCK NUT
				31	F-1521	5	1/2" FLAT WASHER 37 HP ONLY

ANTI-ROTATING CASTER WHEEL ASSEMBLY

NOTE:
BEARING CAP SHOWN
BACKWARDS FOR CLARITY.
PLACE NOTCH IN BACK
WHEN INSTALLING.

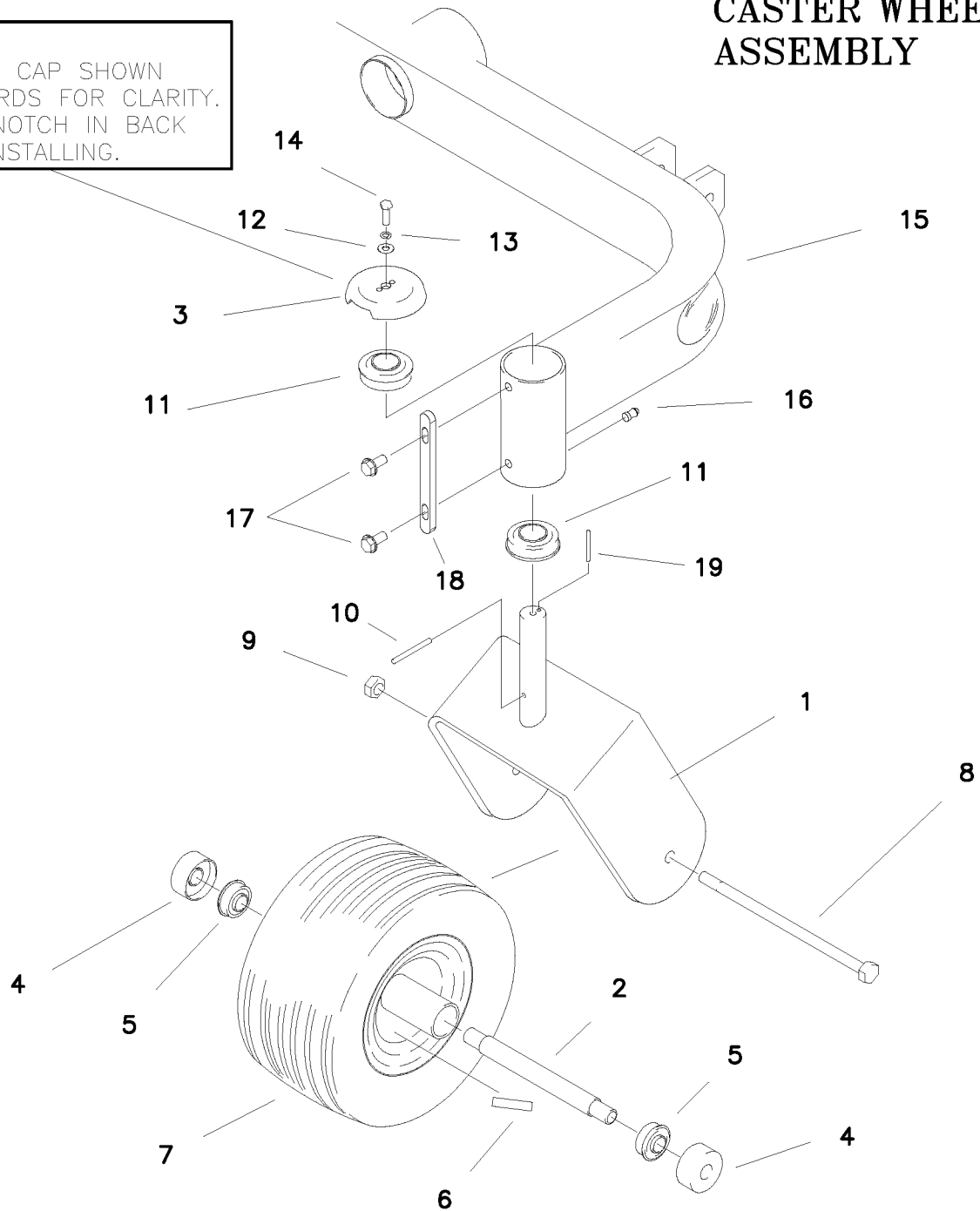

REF NO.	PART NO.	QTY.	DESCRIPTION	REF NO.	PART NO.	QTY.	DESCRIPTION
1	647-192W	1	CASTER YOKE	10	F-1456	2	3/16 ROLL PIN
2	647-038P	2	BEARING SPACER	11	D-2008-02	4	BEARING, SPD SF-16-32
3	636-177P	2	BEARING CAP	12	F-1009-01	2	1/4" FLAT WASHER
4	611-135P	4	BEARING SHIELD	13	F-1019-01	2	1/4" LOCK WASHER
5	D-3432	4	BEARING, 5/8 ID X 1-3/8 OD	14	F-1810	2	1/4-20 X 3/4 W/NYLON PATCH
6	P-11384	2	DECAL, 12, PSI	15	-----	1	SEE PAGE 8 OR 9
7	D-3670	2	TIRE, 13 X 650-6 (RIBBED)	16	H-1056	2	GREASE ZERK
8	F-1908	2	1/2-13 X 9" GR. 8 BOLT	17	F-2030	2	1/4 X 5/8 SELF TAPPING SCREW
9	F-1966	2	1/2-13 THIN NYLOCK NUT	18	659-185P	1	STOP TAB
				19	F-1855	1	3/16 X 1 ROLL PIN

CASTER WHEEL ASSEMBLY

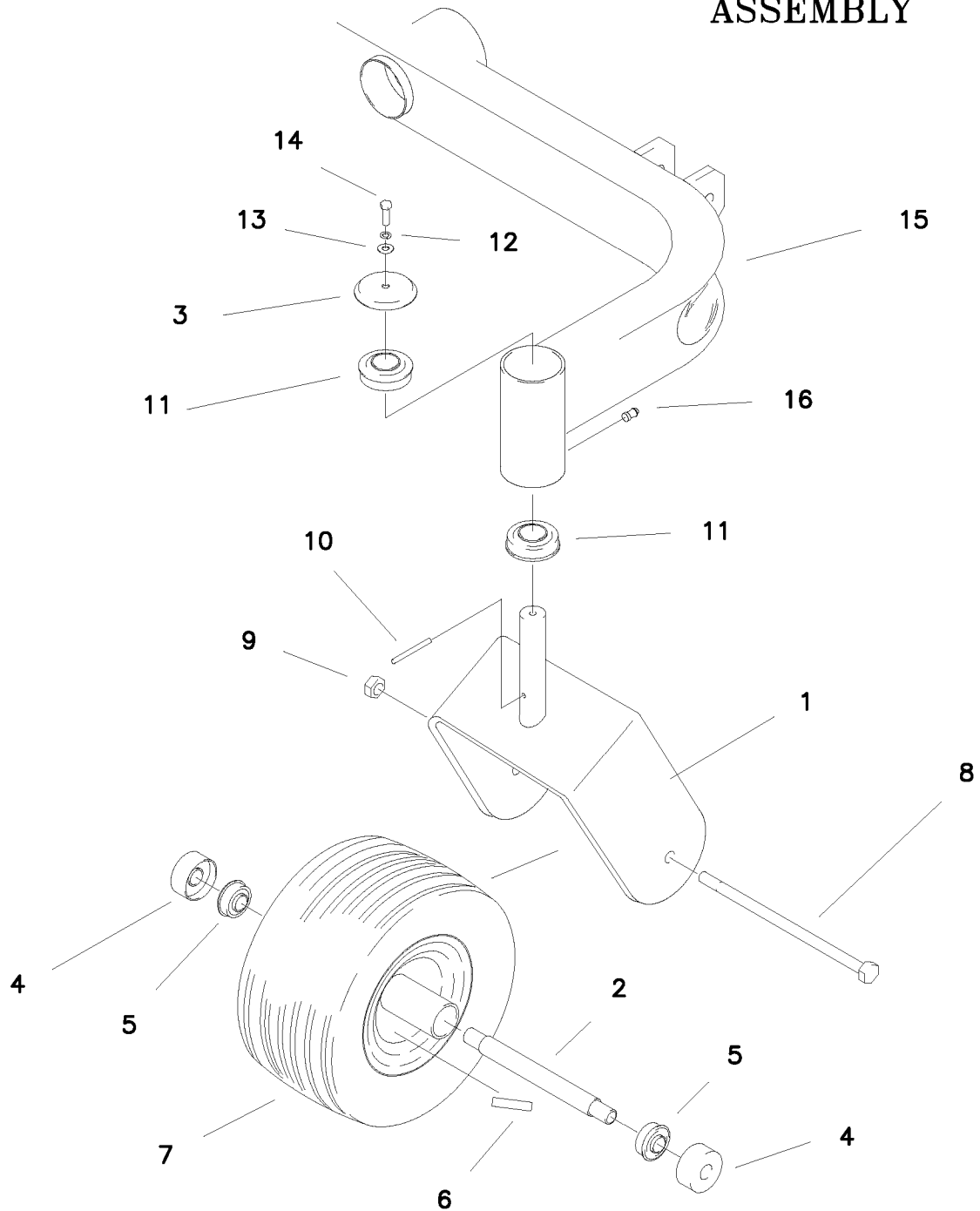

REF NO.	PART NO.	QTY.	DESCRIPTION	REF NO.	PART NO.	QTY.	DESCRIPTION
1	647-003W	1	CASTER YOKE	9	F-1966	2	1/2-13 THIN NYLOCK NUT
2	647-038P	2	BEARING SPACER	10	F-1456	2	3/16 ROLL PIN
3	609-099P	2	BEARING CAP	11	D-2008-02	4	BEARING, SPD SF-16-32
4	611-135P	4	BEARING SHIELD	12	F-1009-01	2	1/4" FLAT WASHER
5	D-3432	4	BEARING, 5/8 ID X 1-3/8 OD	13	F-1019-01	2	1/4" LOCK WASHER
6	P-11384	2	DECAL, 12, PSI	14	F-1810	2	1/4-20 X 3/4 W/NYLON PATCH
7	D-3670	2	TIRE, 13 X 650-6 (RIBBED)	15	-----	1	SEE PAGE 8 OR 9
8	F-1908	2	1/2-13 X 9" GR. 8 BOLT	16	H-1056	2	GREASE ZERK

FRAME SIDES & RELATED PARTS

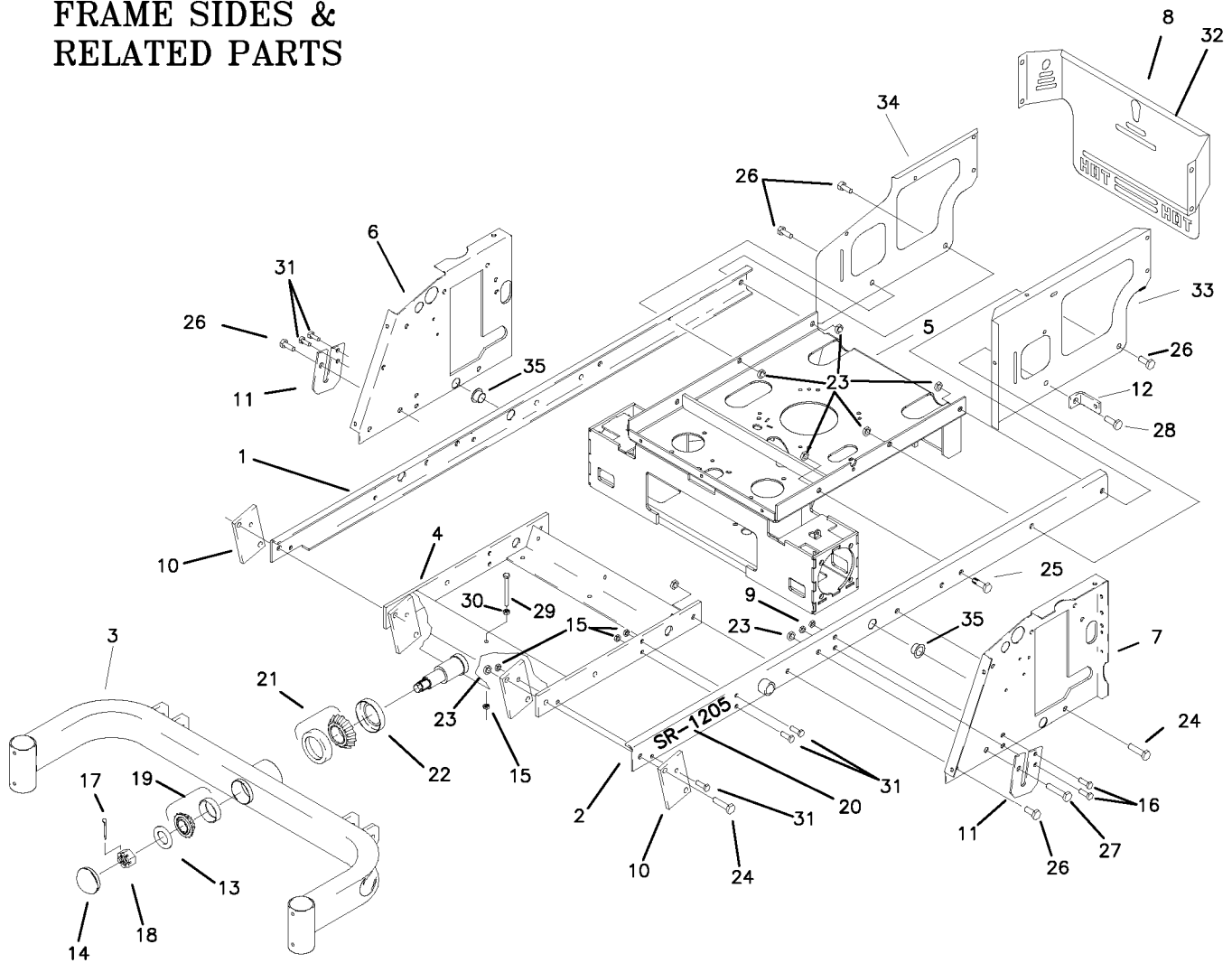

REF NO.	PART NO.	QTY.	DESCRIPTION	REF NO.	PART NO.	QTY.	DESCRIPTION
1	647-143W	1	FRAME SIDE RH.	18	F-1724	1	1"-14 CASTLE NUT
2	647-142W	1	FRAME SIDE LH.	19	D-3782	1	TAPERED BEARING SET
3	642-185W	1	FRONT AXLE	20	----	2	SEE PAGE 16
	642-186W	1	FRONT AXLE (WIDE)	21	D-3646	1	TAPERED ROLLER BRG.
4	642-019W	1	FRONT PIVOT CHANNEL	22	D-3647	1	SEAL, #19992
5	647-188W	1	MOTOR MOUNT WLDT.	23	F-1005-05	10	1/2" LOCK NUT
6	647-195P	1	SIDE PANEL RH.	24	F-1293	4	1/2-13 X 2" GR. 5
7	647-196P	1	SIDE PANEL LH.	25	F-1759	2	1/2-13 X 1" GR.5
8	647-123A	1	ENGINE GUARD REAR W/DECAL	26	F-1386	4	1/2-13 X 1-1/4" GR. 5
9	F-1005-03	2	3/8-16 STOVER NUT	27	F-1828	1	1/2-13 X 3-1/2" GR. 5
10	642-063P	4	DRAG BAR TAB	28	F-1526	1	1/2-13 X 1-1/2" GR. 5
11	642-042P	2	BRAKE ROD MOUNT	29	F-1073	1	3/8-16 X 2" GR. 5
12	642-071W	1	SPRING ANCHOR	30	F-1011-03	1	3/8-16 NUT, UNC-2B
13	606-303P	1	1" WASHER	31	F-1558	10	3/8-16 X 7/8" GR. 5
14	620-206P	1	GREASE CAP	32	P-12097	1	COUNTRY CLIPPER, DECAL
15	F-1239	11	3/8-16 LOCK NUT	33	647-137P	1	LEFT SIDE MOTOR GUARD
16	F-1307	2	3/8-16 X 1-1/4", GR.5	34	647-136P	1	RIGHT SIDE MOTOR GUARD
17	F-1728	1	3/16 X 2" COTTER PIN	35	D-3730	2	BUSHING, JOY STICK

FENDER ASSEMBLY

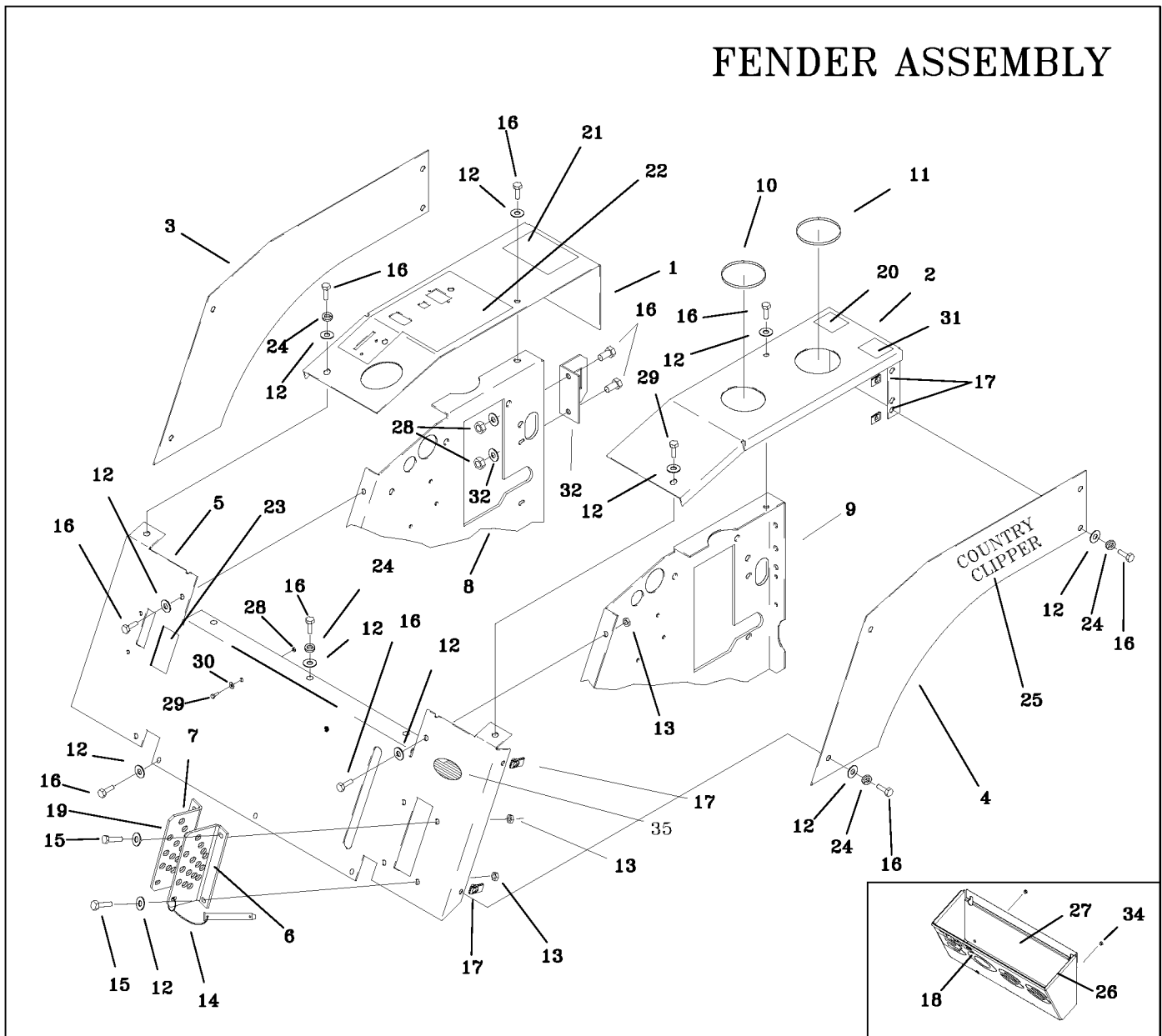

REF NO.	PART NO.	QTY.	DESCRIPTION	REF NO.	PART NO.	QTY.	DESCRIPTION
1	642-133A	1	FENDER CAP RH W/DECAL	16	F-1015-15	21	5/16-18 X 1" GR.5
-	642-140A	-	FDR. CAP RH. 2 LEV. W/DECAL	17	F-1860	8	5/16 U-NUT
-	647-068A	-	FDR. CAP RH. W/EFI DECAL	18	P-12016	1	DECAL, THE BOSS
-	647-067A	-	FDR. CAP RH. 2 LEV. W/EFI DECAL	19	P-12034	1	DECAL, "1/4 CUT HEIGHT"
2	642-170A	1	FENDER CAP LH. W/DECAL	20	P-10939	1	DECAL, "CAUTION"
-	642-171A	-	FDR. CAP LH. 2 LEV. W/DECAL	21	P-11370	1	DECAL, "WARNING"
3	642-134A	1	FENDER SKIRT RH W/DECAL	22	P-11369	1	DECAL, RH. FENDER CAP
4	642-135A	1	FENDER SKIRT LH W/DECAL	23	P-11382	1	DECAL, PARK BRAKE
5	647-116A	1	FRONT PANEL ASS'Y. W/DECAL	24	F-1019-02	15	5/16 LOCK WASHER
-	647-117A	1	FRONT PANEL ASS'Y.	25	P-11112	2	DECAL, "COUNTRY CLIPPER"
6	647-095P	1	LATCH PLATE LH.	26	647-114P	1	TRIM, TOOL TRAY
7	647-097A	1	LATCH PLATE, RH, W/DECAL	27	647-115A	1	TOOL TRAY ASSEMBLY
8	642-049P	1	SIDE PANEL RH.	28	F-1158	4	1/4-20 STOVER NUT
9	642-050P	1	SIDE PANEL LH.	29	F-1015-02	4	1/4-20 X 5/8" BOLT
10	644-029P	1	TRIM, FUEL TANK	30	H-1989	2	SHOULDER WASHER
11	644-030P	1	TRIM, OIL TANK	31	P-11052	2	DECAL, OIL
12	F-1009-02	27	5/16 FLAT WASHER	32	647-146P	1	FUSE HOLDER
13	F-1125	16	5/16-18 LOCK NUT	33	F-1009-01	2	1/4" FLAT WASHER
14	F-1807	1	1/2" X 2.4 CLEVIS PIN W/SASH	34	H-2461	2	RUBBER BUMPER
15	F-1879	3	5/16-18 X 1-1/4" GR. 5	35	P-12253	1	DECAL, MADE IN USA

SEAT, FOOTDECK & RELATED PARTS

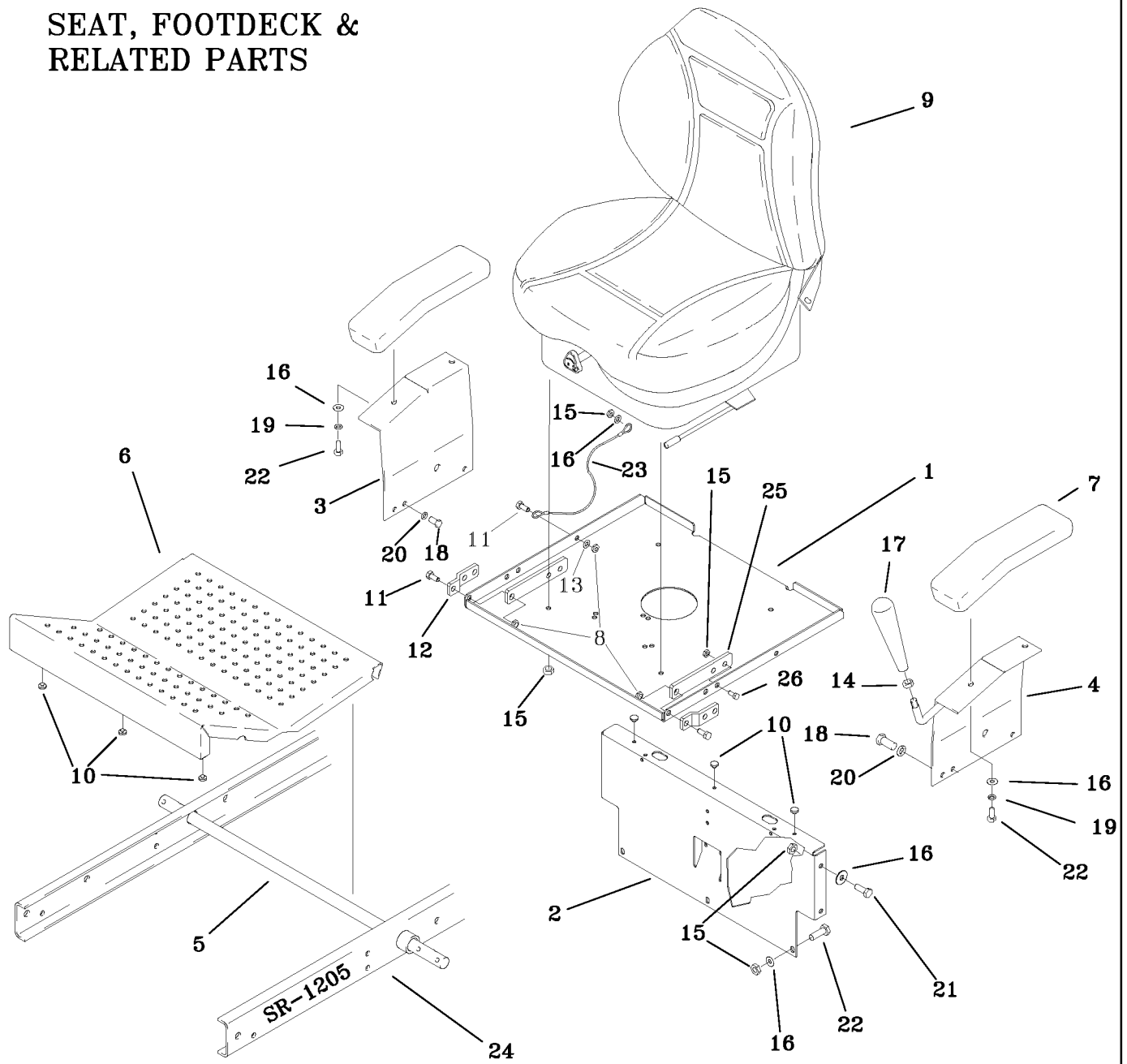

REF NO.	PART NO.	QTY.	DESCRIPTION	REF NO.	PART NO.	QTY.	DESCRIPTION
1	647-087P	1	SEAT BRACKET	12	647-086P	2	SEAT MTG TAB
2	647-088P	1	REAR BRACE	13	F-1009-03	2	3/8 FLAT WASHER
3	647-047P	1	ARM REST RH. (JOYSTICK)	14	F-1011-03	1	3/8-16 PLAIN NUT
-	636-163P	1	ARM REST, (TWIN STICK)	15	F-1005-02	16	5/16-18 LOCK NUT
4	647-049W	1	ARM REST LH. (JOYSTICK)	16	F-1009-02	12	5/16 FLAT WASHER
-	636-163P	1	ARM REST, (TWIN STICK)	17	H-2317	1	TAPERED GRIP BALL
5	620-051P	1	LIFT BAR	18	F-1755	4	3/8-16 X 1/2" GR. 5
6	642-044P	1	FOOT DECK	19	F-1019-02	4	5/16 LOCK WASHER
7	621-143A	2	ARM REST PAD	20	F-1019-03	4	3/8 LOCK WASHER
8	F-1005-03	4	3/8-16 STOVER NUT	21	F-1546	4	5/16-18 X 3/4" GR. 5
9	H-2274	1	DELUXE SEAT	22	F-1015-15	8	5/16-18 X 1" GR. 5
-	H-2229	-	STANDARD SEAT	23	H-2460	1	CABLE
10	H-2461	6	RUBBER BUMPER	24	P-12189	2	SR-1205, DECAL
11	F-1015-23	1	3/8-16 X 3/4" GR. 5	25	659-175P	2	SEAT HINGE TAB
				26	F-1547	4	5/16-18 X 3/4" BOLT

FUEL INJECTION FUEL LINE ASSEMBLY

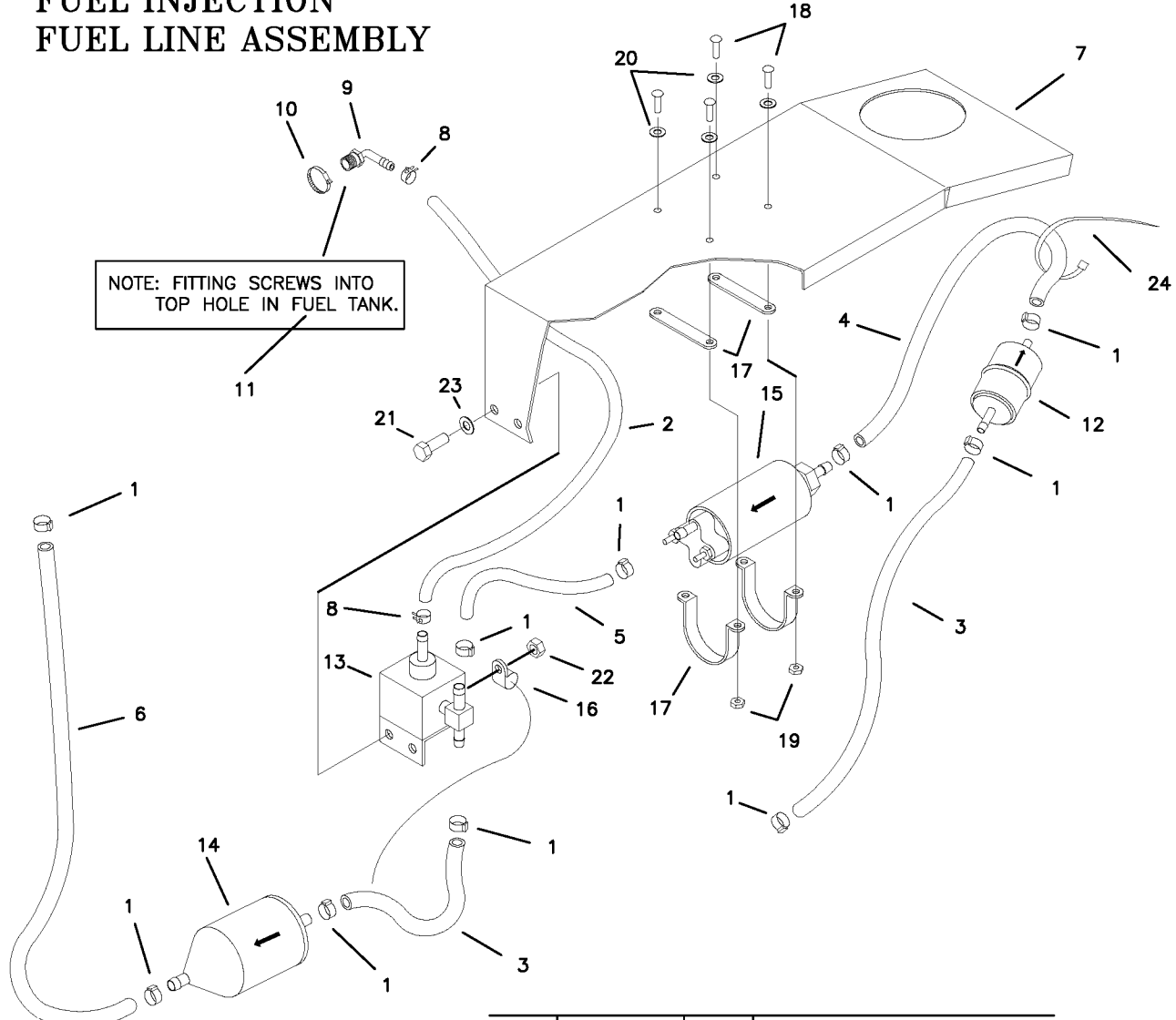

REF NO.	PART NO.	QTY.	DESCRIPTION
1	H-2336	10	HOSE CLAMP
2	647-063P	1	46" FUEL LINE, 1/4" ID
3	647-059P	1	7" FUEL LINE, 5/16" ID
4	647-060P	1	14" FUEL LINE, 5/16" ID
5	647-061P	1	5" FUEL LINE, 5/16" ID
6	647-062P	1	16" FUEL LINE, 5/16" ID
7	-	1	FENDER CAP RH
8	H-1687	2	HOSE CLAMP RH
9	H-1646	1	HOSE BARB
10	H-1952	1	HOSE CLAMP
11	647-058P	1	FUEL TANK FOR EFI
12	H-2335	1	FUEL FILTER
13	H-2339	1	REGULATOR
14	H-2338	1	FILTER, BOSCH
15	H-2340	1	FUEL PUMP
16	H-2337	1	LOOP CLAMP
17	H-2341	2	PUMP MOUNTING BANDS & BARS
18	F-1022-26	4	MACHINE SCREWS, 10-32 X 58"
19	F-1448	4	10-32 LOCK NUT
20	F-1071	4	FLAT WASHER
21	F-1538	2	1/4-20 X 3/4" GR 5
22	F-1158	2	1/4" LOCK NUT
23	F-1009-01	2	1/4" FLAT WASHER
24	E-5884	1	WIRE TIE

FUEL TANK ASSEMBLY

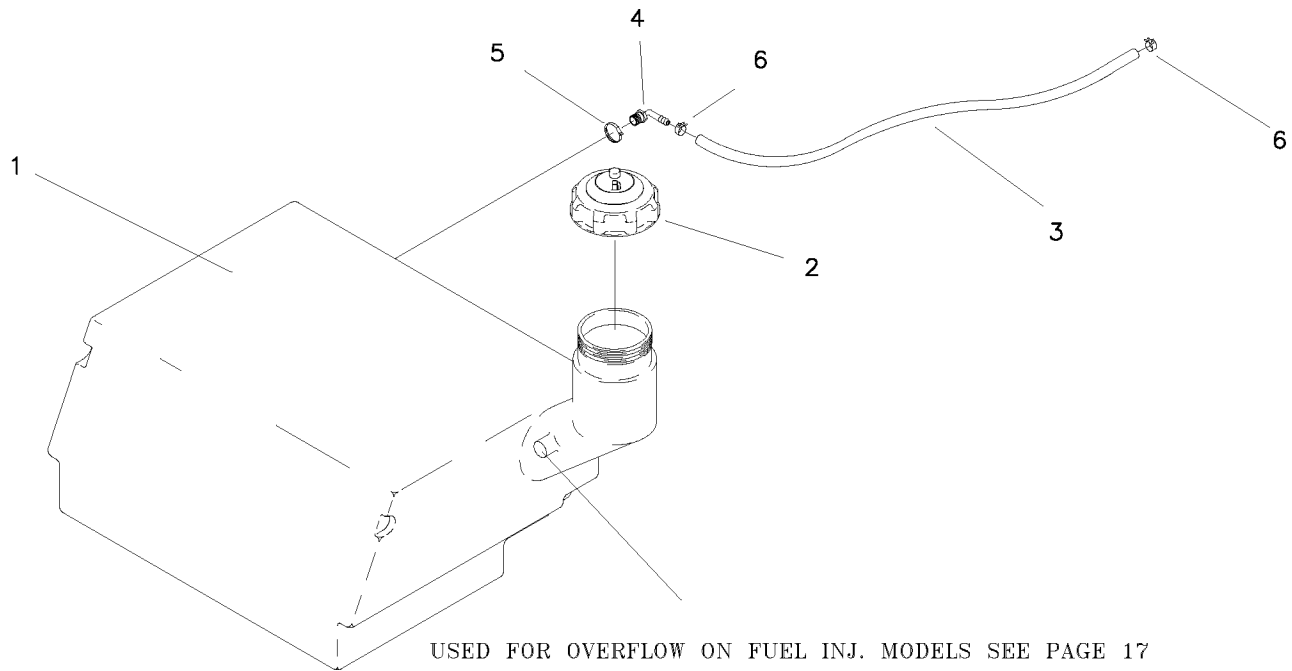

REF NO.	PART NO.	QTY.	DESCRIPTION
1	H-2234	1	11 GALLON TANK
2	H-2232	1	GAS CAP
3	644-034P	1	29-1/2" FUEL LINE
4	H-1646	1	HOSE BARB, 90 DEG.
5	H-1952	1	HOSE CLAMP
6	H-1687	2	HOSE CLAMP, 1/2"
7	647-063P	1	46" LONG 1/4" ID FUEL LINE

JACK ASSEMBLY

Parts List			
ITEM	QTY	PART NO.	DESCRIPTION
1	1	629-620P	JACK END
2	1	629-527P	THRUST TUBE
3	1	629-528P	SHAFT, JACK
4	1	D-3675	THRUST BEARING 1/2 INCH ID
5	2	F-1120	BALL PLUNGER
6	1	F-1855	ROLL PIN, 3/16 X 1
7	2	F-1831	3/16 x 1" SPIROL PIN
8	1	629-529P	EXTENSION TUBE, JACK
9	1	629-216P	CRANK HANDLE
10	1	H-2343	KNOB
11	1	F-1913	PUSH RETAINER 3/8 INCH
12	1	F-2015	SNAP RING 1 3/8 INTERNAL
13	1	629-531P	JACK BASE PLATE, TIPPED
14	2	629-549P	SPACER
15	4	F-1019-03	3/8" LOCKWASHER
16	2	F-1015-23	3/8-16 x 3/4" CAPSCREW
17	1	F-1307	3/8-16 x 1-1/4" CAPSCREW
18	2	F-1558	3/8-16 x 7/8" CAPSCREW
19	3	629-532P	SPACER
20	1	629-564P	UPPER HANDLE EXTENSION
21	2	D-3432	BEARING 5/8" I.D. 1-3/8" O.D.
22	1	629-621W	YOKE WELDMENT
23	2	D-3814	BEARING THRUST WASHER .50 ID
24	1	629-623P	
25	1	F-1492	5/16-3/8 Rue Ring
26	2	F-1335	ROLL PIN, 1/8 X 1

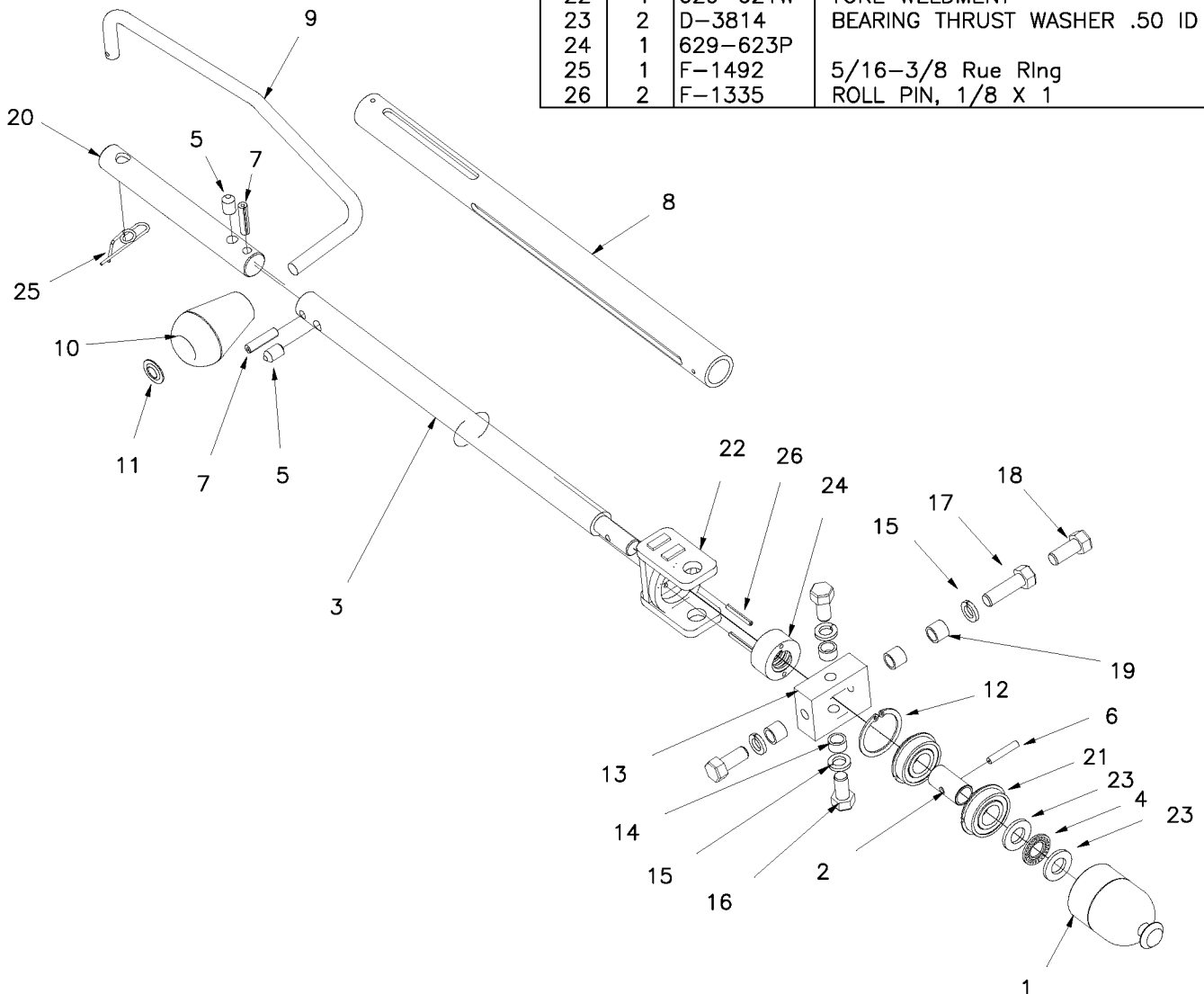

JOYSTICK HD STEERING CONTROL AND RELATED PARTS

NOTE; ITEM'S #2 AND #3 MUST BE REPLACED AT THE SAME TIME FOR MAXIMUM PERFORMANCE.

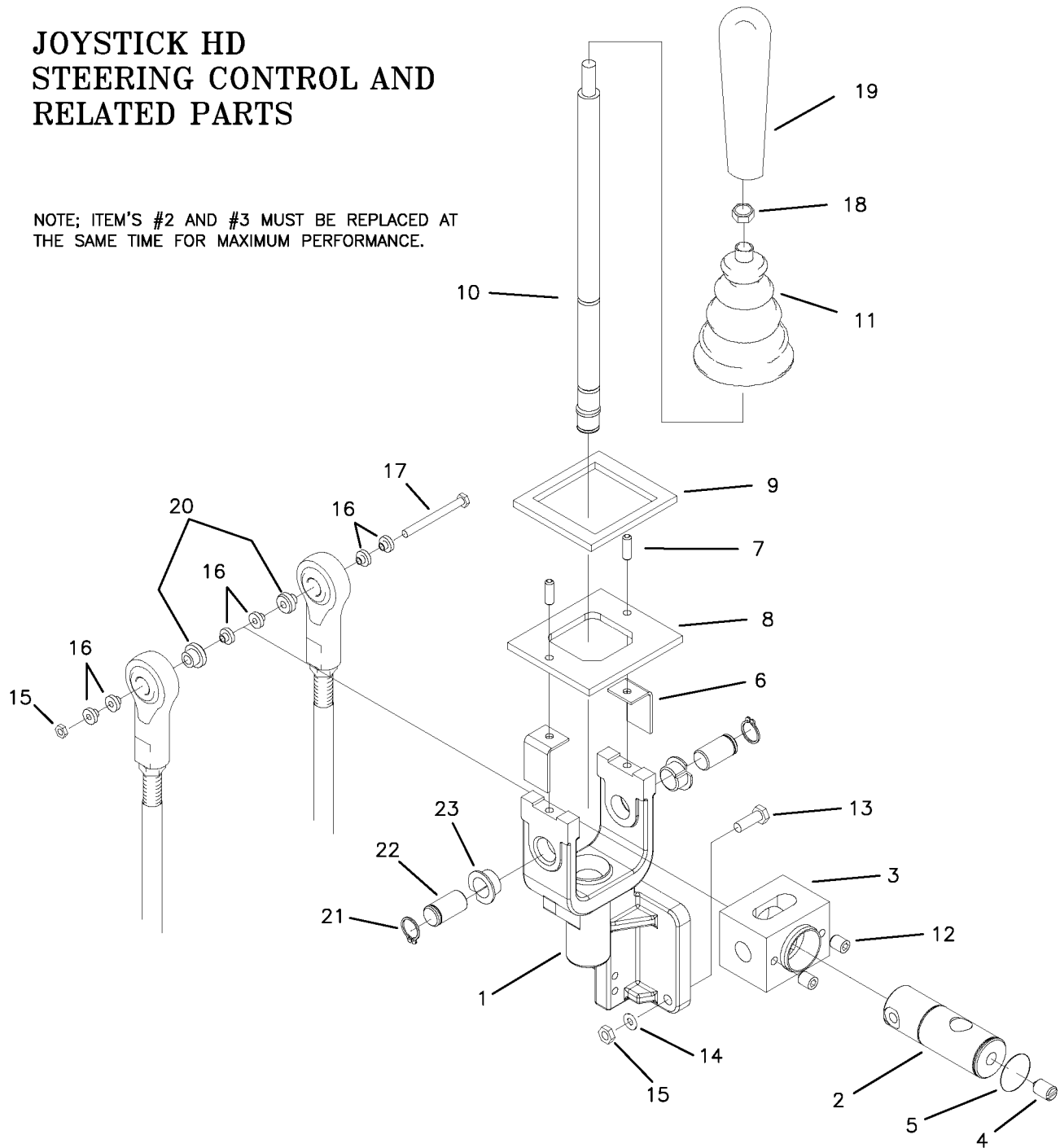

REF NO.	PART NO.	QTY.	DESCRIPTION	REF NO.	PART NO.	QTY.	DESCRIPTION
-	647-110A	1	JOYSTICK ASSEMBLY	12	F-1228	2	1/4-28 SET SCREW
1	647-105P	1	JOYSTICK YOKE	13	F-1015-05	3	1/4-20 X 1" HHCS GR. 5
2	647-104P	1	PIVOT SHAFT	14	F-1019-01	3	1/4" LOCK WASHER
3	647-101P	1	PIVOT BLOCK	15	F-1158	4	1/4-20 LOCK NUT
4	F-1120	1	BALL PLUNGER	16	H-1989	6	BUSHING, BALL JOUNT
5	F-1998	1	SNAP RING, SPIRLOCK	17	F-1020-01	1	1/4-20 X 3-1/2" GR. 5
6	647-106P	2	RETAINING PLATE	18	F-1011-03	1	3/8-16 NUT, JAM
7	F-1999	2	ROLL PIN	19	H-2317	1	HANDLE GRIP, TAPERED
8	659-129P	1	JOYSTICK TOP PLATE	20	H-2465	2	1/4" SPACER
9	H-1947	1	GASKET, FOAM	21	F-1740	2	SNAP RING
10	621-140A	1	JOYSTICK SHAFT ASSEMBLY	22	647-103P	2	PIVOT PIN
11	H-1991	1	BOOT	23	D-3784	2	BUSHING

**JOYSTICK STEERING
CONTROL AND
RELATED PARTS
(continued)**

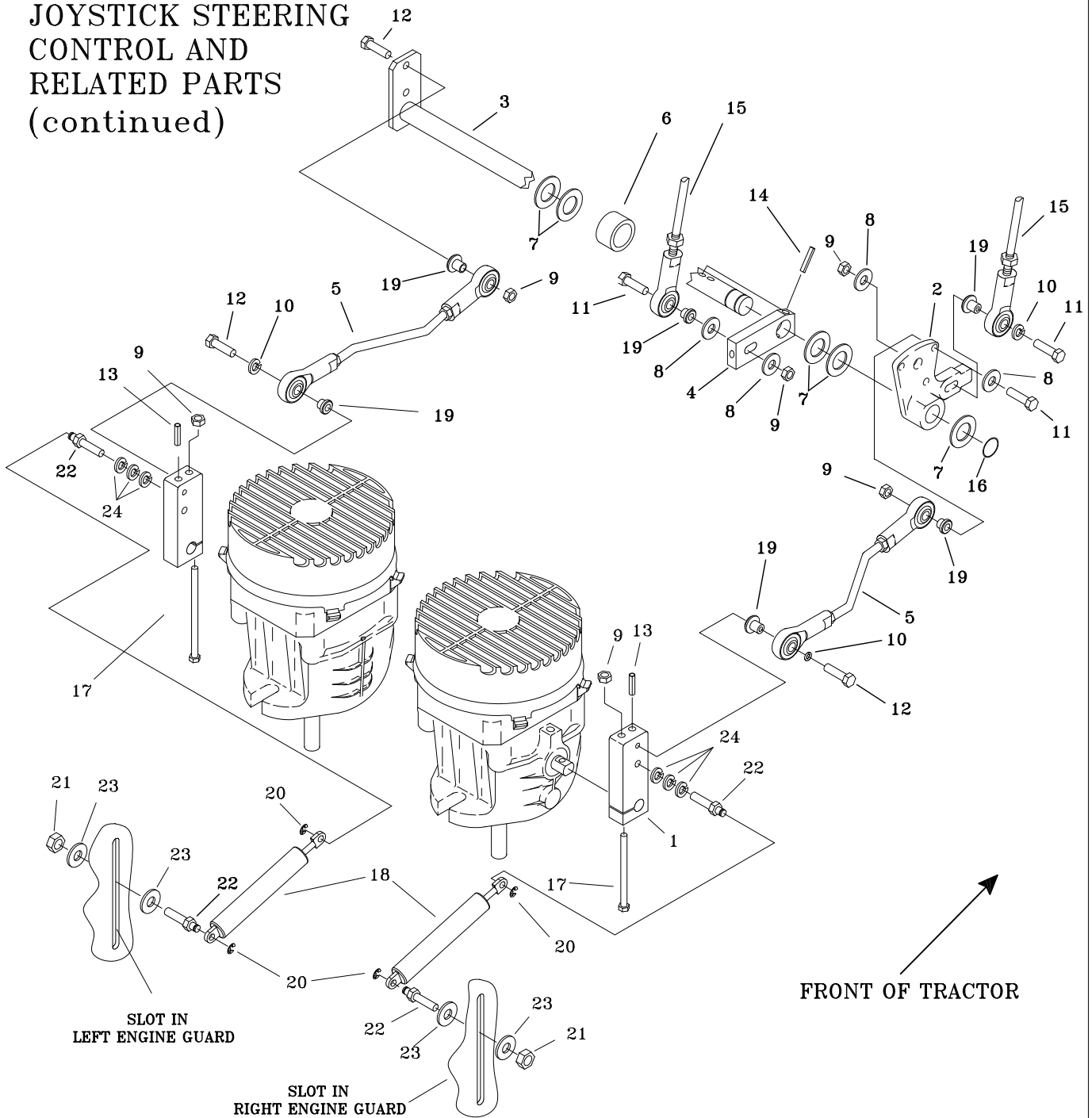

REF NO.	PART NO.	QTY.	DESCRIPTION	REF NO.	PART NO.	QTY.	DESCRIPTION
1	647-189P	2	SHIFT ARM	13	F-1725	2	ROLL PIN, 5MM X 26MM
2	638-027A	1	LINKAGE DISK ASSEMBLY	14	F-1503	2	ROLL PIN, 3/16" X 1"
3	636-078W	1	SHIFT ROD	15	647-082P	2	LOWER LINKAGE
4	625-030P	1	SWIVEL ARM	16	F-1739	1	SPIROL RING
5	647-083P	2	UPPER LINKAGE ROD	17	F-1020-07	2	1/4-20 X 4" BOLT
6	647-197P	1	SPACER	18	H-2467	2	DUAL ACTION DAMPER, LIGHT
7	610-103P	5	THRUST WASHER	19	H-2465	6	1/4 X 5/16 SHOULDER WASHER
8	F-1009-01	4	1/4" FLAT WASHER	20	F-1610	2	E-RING
9	F-1158	6	1/4-20 LOCK NUT	21	F-1125	2	5/16-18 LOCK NUT
10	F-1019-01	2	1/4-20 LOCK WASHER	22	638-028P	4	5/16-18 DAMPER BOLT
11	F-1716	2	1/4-20 X 1-1/2", GR.5	23	F-1009-02	4	5/16 FLAT WASHER
12	F-1015-05	3	1/4-20 X 1" GR. 5	24	F-1019-02	6	5/16 LOCK WASHER

RIGHT HAND STEERING CONTROL AND RELATED PARTS

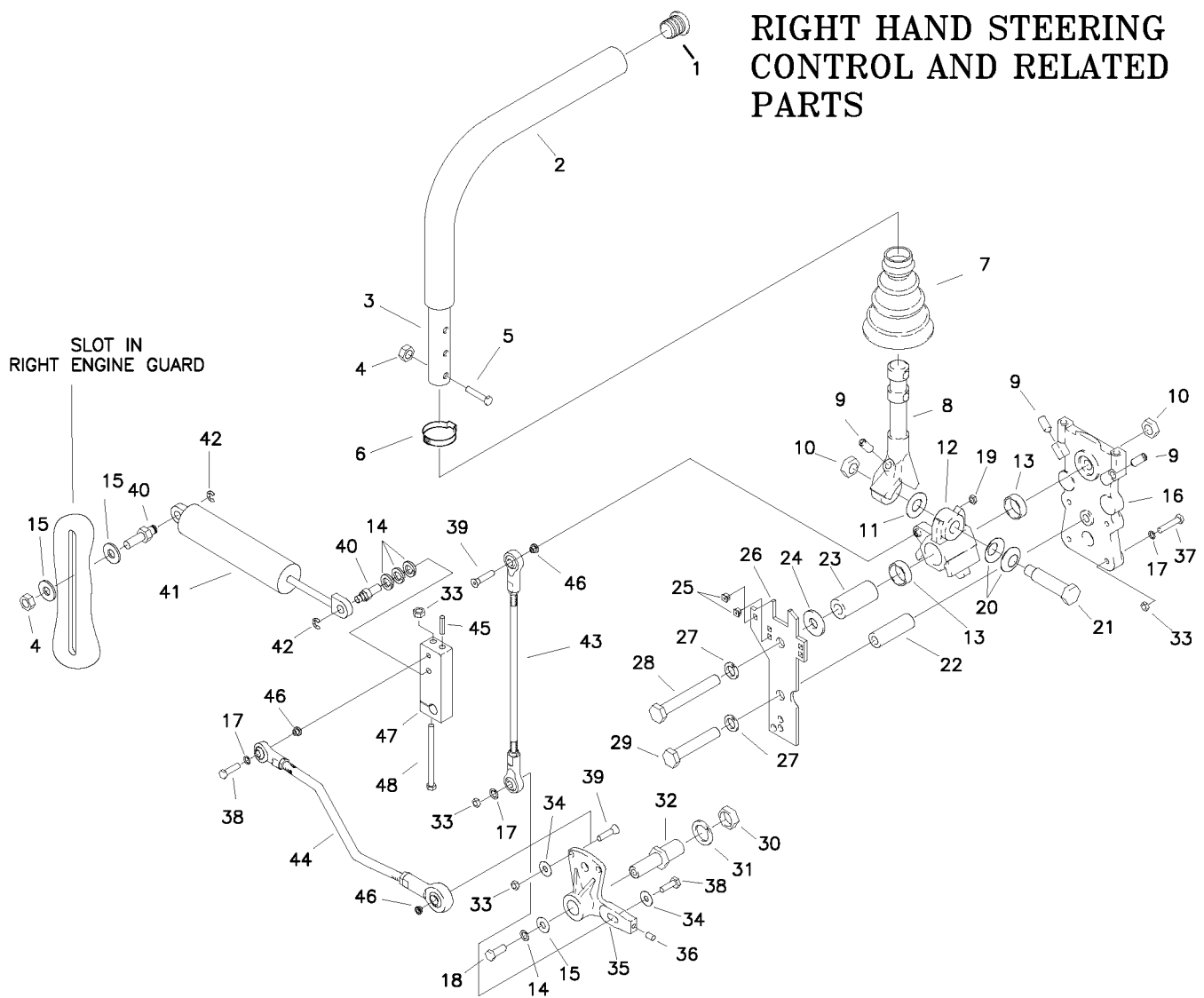

REF NO.	PART NO.	QTY.	DESCRIPTION	REF NO.	PART NO.	QTY.	DESCRIPTION
1	H-2080	1	END PLUG, 15/16" BLACK	-	F-1847	2	GROMMET, #4 X 1/4" SQ.
2	H-2079	1	FOAM GRIP, 17"	26	636-167P	1	SIDE PLATE, DUALEVER
3	642-004A	1	CONTROL LEVER ASSEMBLY	27	F-1464	2	1/2" LOCK WASHER
4	F-1125	2	5/16 LOCK NUT	28	F-1828	1	1/2-13 X 3-1/2" HHCS GR. 5
5	F-1015-17	2	5/16-18 X 1-1/2" HHCS GR. 5	29	F-1439	1	1/2-13 X 3" HHCS GR. 5
6	H-2089	1	HOSE CLAMP, 1-1/4"	30	F-1011-07	1	3/4-10 PLAIN NUT
7	H-2081	1	BOOT, TAPERED 1" CUFF	31	F-1463	1	3/4" LOCK WASHER
8	625-063P	1	LEVER, DUALEVER	32	623-048P	1	LINKAGE PINTLE
9	F-1842	3	SETSCREW, 5/16-18 X 3/4"	33	F-1158	4	1/4-20 LOCK NUT
10	F-1489	2	1/2-13 JAM NUT	34	F-1009-01	2	1/4" FLAT WASHER
11	H-2116	1	WASHER, FIBER	35	647-099A	1	LINKAGE DISK ASSEMBLY
12	638-033P	1	PIVOT BLOCK, DUALEVER	36	F-1695	1	SETCREW, 1/4-20 X 3/8"
13	D-3622	2	BEARING	37	F-1539	3	1/4-20 X 1-1/4" HHCS GR. 5
14	F-1019-02	4	5/16" LOCK WASHER	38	F-1015-05	2	1/4-20 X 1" HHCS GR5
15	F-1009-02	3	WASHER, FLAT STD. 5/16"	39	F-1974	2	1/4-20 X 1-1/4" FLAT HEAD
16	638-034P	1	BASE DUALEVER	40	638-028P	2	5/16 DAMPER BOLT
17	F-1019-01	3	1/4" LOCK WASHER	41	H-2168	1	STEERING DAMPER
18	F-1015-05	1	1/4-20 X 1" HHCS GR. 5	42	F-1610	1	E-RING FOR 1/4" SHAFT
19	F-1748	1	1/4-20 THIN NYLOC NUT	43	647-082P	1	UPPER LINKAGE
20	H-2115	2	WASHER, SPRING	44	647-083P	1	LOWER LINKAGE
21	625-070P	1	SHOULDER BOLT, 5/8" OD	45	F-1725	1	ROLL PIN, 5MM X 26MM
22	625-067P	1	BUSHING, STAND OFF	46	H-2465	3	1/4 X 5/16 SHOULDER WASHER
23	625-064P	1	BUSHING, PIVOT BLOCK	47	647-189P	1	SHIFT ARM
24	625-072P	1	WASHER, FLAT	48	F-1020-07	1	1/4-20 X 4" BOLT
25	F-1995	2	GROMMET, #10, SR-1200				

LEFT HAND STEERING CONTROL AND RELATED PARTS

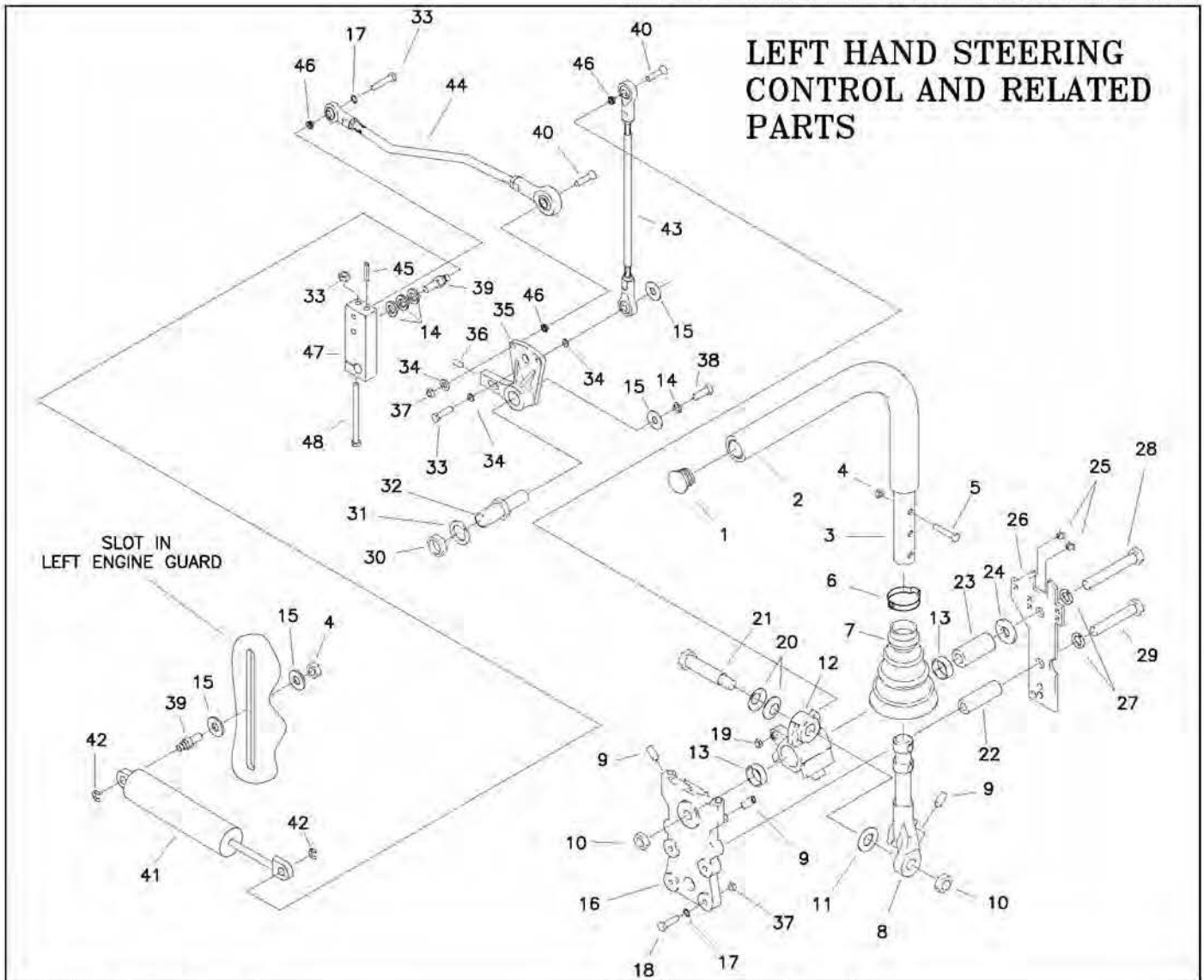

REF NO.	PART NO.	QTY.	DESCRIPTION	REF NO.	PART NO.	QTY.	DESCRIPTION
1	H-2080	1	END PLUG, 15/16" BLACK	25	F-1995	2	GROMMET, #10, SR-1200
2	H-2079	1	FOAM GRIP, 17"	-	F-1847	2	GROMMET, #4 X 1/4" SQ.
3	642-004A	1	CONTROL LEVER ASSEMBLY	26	636-167P	1	SIDE PLATE, DUALEVER
4	F-1125	3	5/16 LOCK NUT	27	F-1464	2	1/2" LOCK WASHER
5	F-1015-17	2	5/16-18 X 1-1/2" HHCS GR. 5	28	F-1828	1	1/2-13 X 3-1/2" HHCS GR. 5
6	H-2089	1	HOSE CLAMP 1-1/4"	29	F-1439	1	1/2-13 X 3" HHCS GR. 5
7	H-2081	1	BOOT, TAPERED 1" CUFF	30	F-1011-07	1	3/4-10 PLAIN NUT
8	625-063P	1	LEVER, DUALEVER	31	F-1463	1	3/4" LOCK WASHER
9	F-1842	3	SETSCREW, 5/16-18 X 3/4"	32	623-048P	1	LINKAGE PINTLE
10	F-1489	2	1/2-13 JAM NUT	33	F-1716	1	1/4-20 X 1-1/2" HHCS GR. 5
11	H-2116	1	WASHER, FIBER	34	F-1009-01	4	1/4" FLAT WASHER
12	638-033P	1	PIVOT BLOCK, DUALEVER	35	647-099A	1	LINKAGE DISK ASSEMBLY
13	D-3622	2	BEARING	36	F-1695	1	SETCREW, 1/4-20 X 3/8"
14	F-1019-02	4	5/16" LOCK WASHER	37	F-1158	4	1/4-20 LOCK NUT
15	F-1009-02	3	WASHER, FLAT STD. 5/16"	38	F-1015-14	1	5/16-18 X 7/8" HHCS GR. 5
16	638-034P	1	BASE DUALEVER	39	638-028P	1	DAMPER BOLT, 5-16-18 X 3/4"
17	F-1019-01	4	1/4" LOCK WASHER	40	F-1974	2	1/4-20 X 1-1/4" SOCK BOLT
18	F-1559	3	1/4-20 X 1-1/4" HHCS GR. 5	41	H-2168	1	STEERING DAMPER
19	F-1748	1	1/4-20 THIN NYLOC NUT	42	F-1610	2	E-RING FOR 1/4" SHAFT
20	H-2115	2	WASHER, SPRING	43	647-082P	1	UPPER LINKAGE
21	625-070P	1	SHOULDER BOLT, 5/8" OD	44	647-083P	1	LOWER LINKAGE
22	625-067P	1	BUSHING, STAND OFF	45	F-1725	1	ROLL PIN 5MM X 26MM
23	625-064P	1	BUSHING, PIVOT BLOCK	46	H-2465	3	1/4" SHOULDER WASHER
24	625-072P	1	WASHER, FLAT	47	647-189P	1	SHIFT ARM
				48	F-1020-07	1	1/4-20 X 4" BOLT

PARKING BRAKE ASSEMBLY & RELATED PARTS

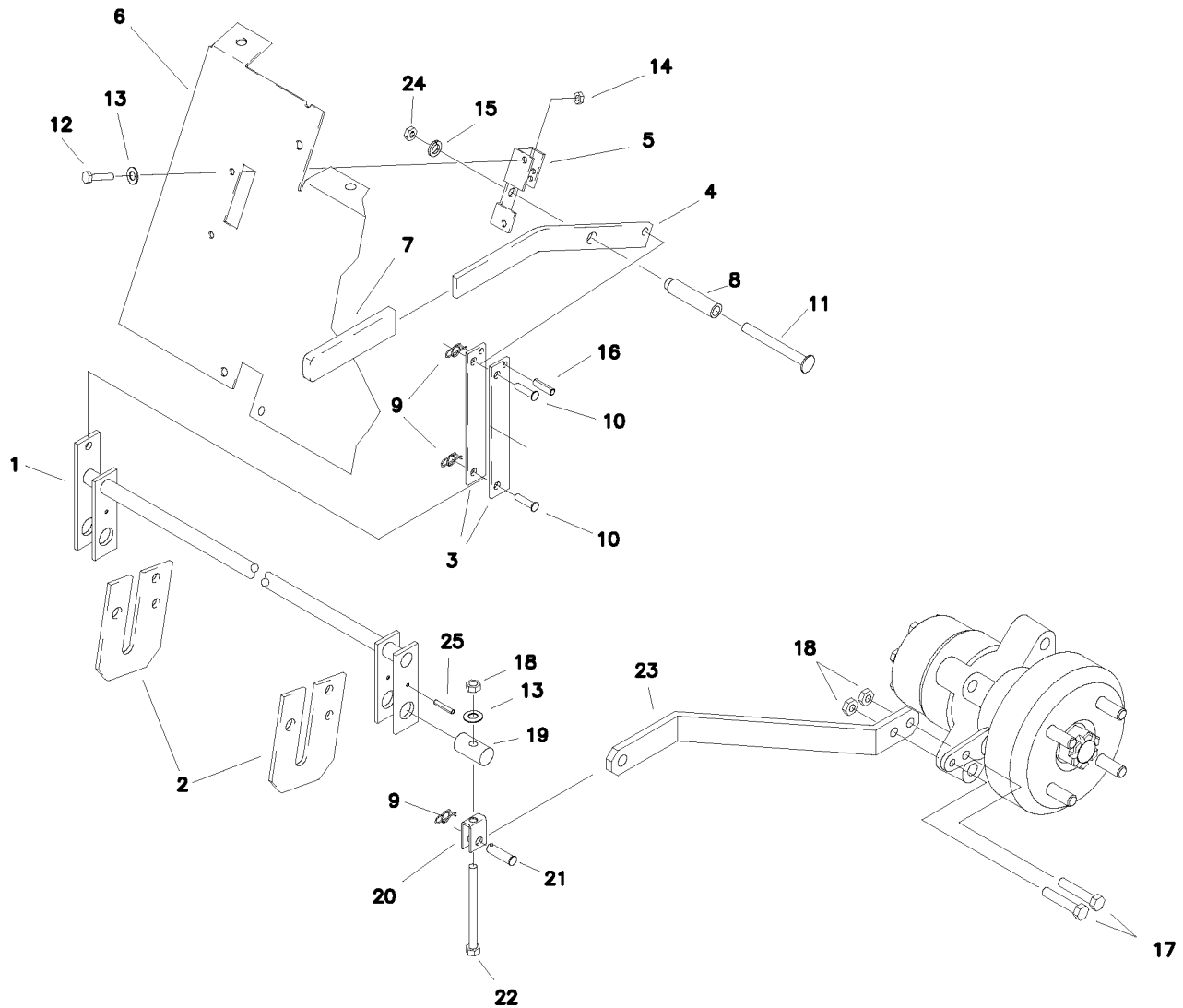

REF NO.	PART NO.	QTY.	DESCRIPTION	REF NO.	PART NO.	QTY.	DESCRIPTION
1	647-014W	1	BRAKE ROD WELDMENT	17	F-1015-15	4	5/16-18 X 1" BOLT
2	642-042P	2	BRAKE ROD MOUNT	18	F-1125	6	5/16-18 LOCK NUT
3	642-058P	2	BRAKE LINK	19	642-067P	2	TOP HANGER PIN
4	642-056P	1	BRAKE HANDLE	20	647-030P	2	BRAKE YOKE LINKAGE
5	642-054P	1	BRAKE SWITCH BRACKET	21	F-1444	2	CLEVIS PIN 3/8 X 1-5/16"
6	642-057P	1	FRONT PANEL	22	F-1153	2	5/16-18 X 4.5" GR. 5
7	H-1926	1	HANDLE GRIP	23	647-145P	2	BRAKE ARM
8	642-027P	1	BRAKE PIVOT TUBE	-	647-157P	2	BRAKE ARM, FOR 52" MODEL
9	F-1492	3	RUE RING	24	F-1005-03	1	3/8-16 LOCK NUT
10	F-1443	2	5/16" PIN	25	F-1604	2	ROLL PIN
11	F-1982	1	3/8-16 X 3-1/2" CARRIAGE				
12	F-1538	2	1/4-20 X 3/4" GR. 5				
13	F-1009-01	4	1/4" FLAT WASHER				
14	F-1005-01	2	1/4-20 LOCK NUT				
15	F-1019-03	1	3/8" LOCK WASHER				
16	F-1831	2	1/4 X 1" ROLL PIN				

GEAR MOTOR, WHEEL ASSEMBLY

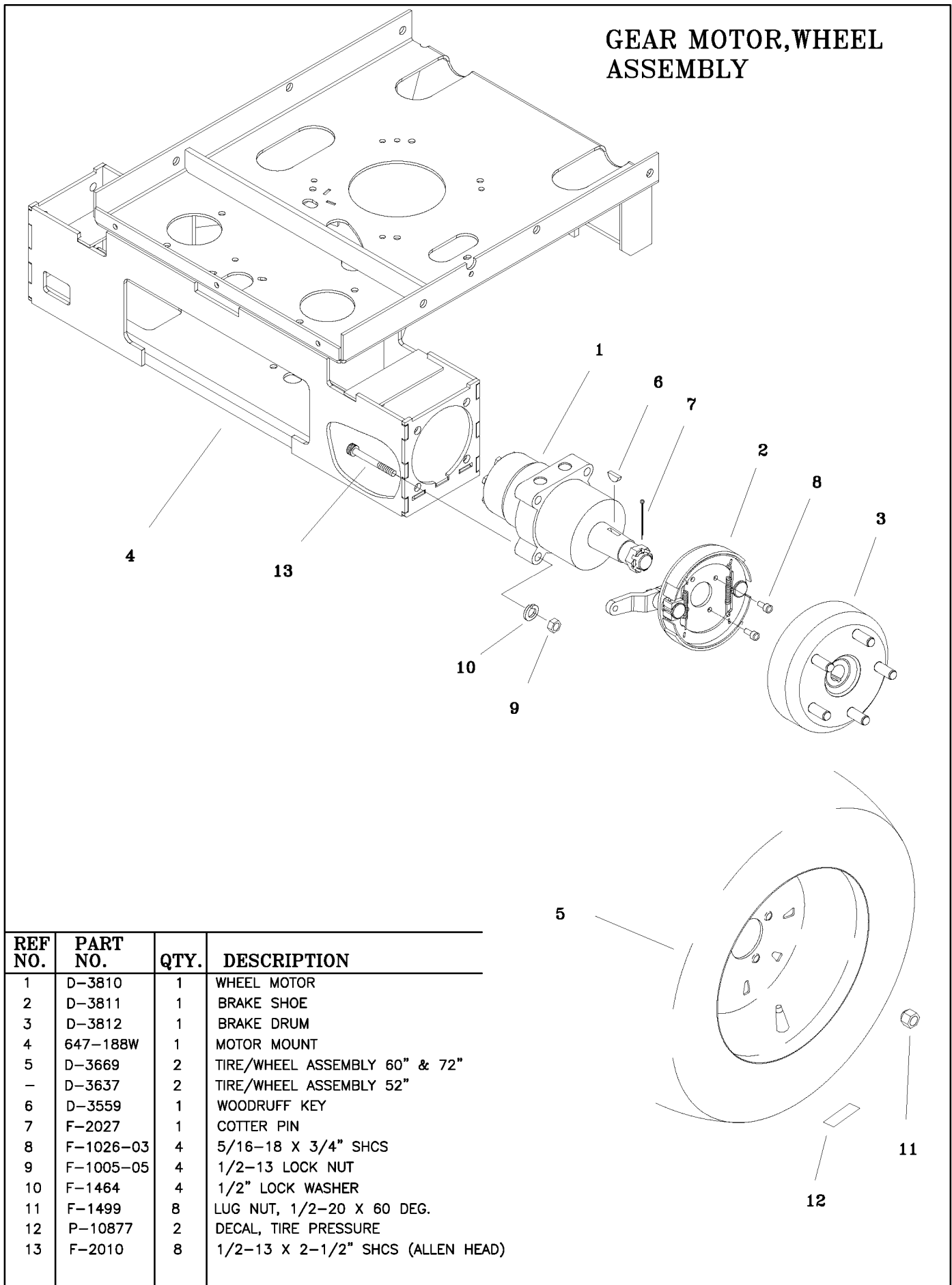

REF NO.	PART NO.	QTY.	DESCRIPTION
1	D-3810	1	WHEEL MOTOR
2	D-3811	1	BRAKE SHOE
3	D-3812	1	BRAKE DRUM
4	647-188W	1	MOTOR MOUNT
5	D-3669	2	TIRE/WHEEL ASSEMBLY 60" & 72"
-	D-3637	2	TIRE/WHEEL ASSEMBLY 52"
6	D-3559	1	WOODRUFF KEY
7	F-2027	1	COTTER PIN
8	F-1026-03	4	5/16-18 X 3/4" SHCS
9	F-1005-05	4	1/2-13 LOCK NUT
10	F-1464	4	1/2" LOCK WASHER
11	F-1499	8	LUG NUT, 1/2-20 X 60 DEG.
12	P-10877	2	DECAL, TIRE PRESSURE
13	F-2010	8	1/2-13 X 2-1/2" SHCS (ALLEN HEAD)

**HIGH PRESSURE
LINES & FITTINGS
FOR 52" BOSS**

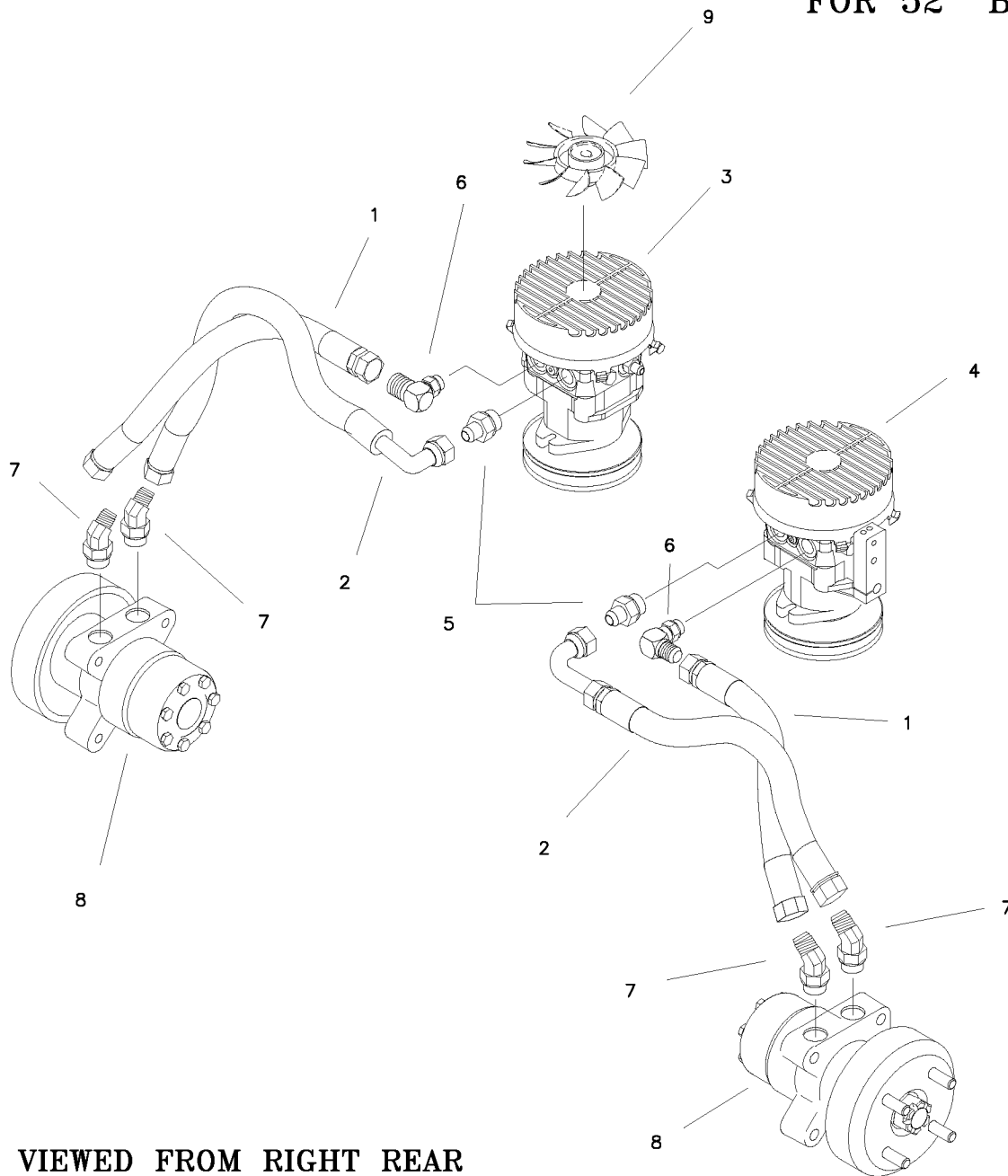

VIEWED FROM RIGHT REAR

REF NO.	PART NO.	QTY.	DESCRIPTION
1	H-2571	2	HOSE ASS'Y. 10" LONG
2	H-2492	2	HOSE ASS'Y. 16-1/2" LONG
3	D-3780-01	1	HYDRO PUMP, 12CC LH
4	D-3780-02	1	HYDRO PUMP, 12CC RH
5	H-2436	2	FITTING, STRAIGHT
6	H-2495	2	FITTING, 90°
7	H-2572	4	FITTING, 45°
8	----	-	SEE PAGE 25
9	D-3804	2	REPLACEMENT FAN BLADE

H-2570 PLUMBING KIT

**HIGH PRESSURE
LINES & FITTINGS
FOR 60 & 72" BOSS**

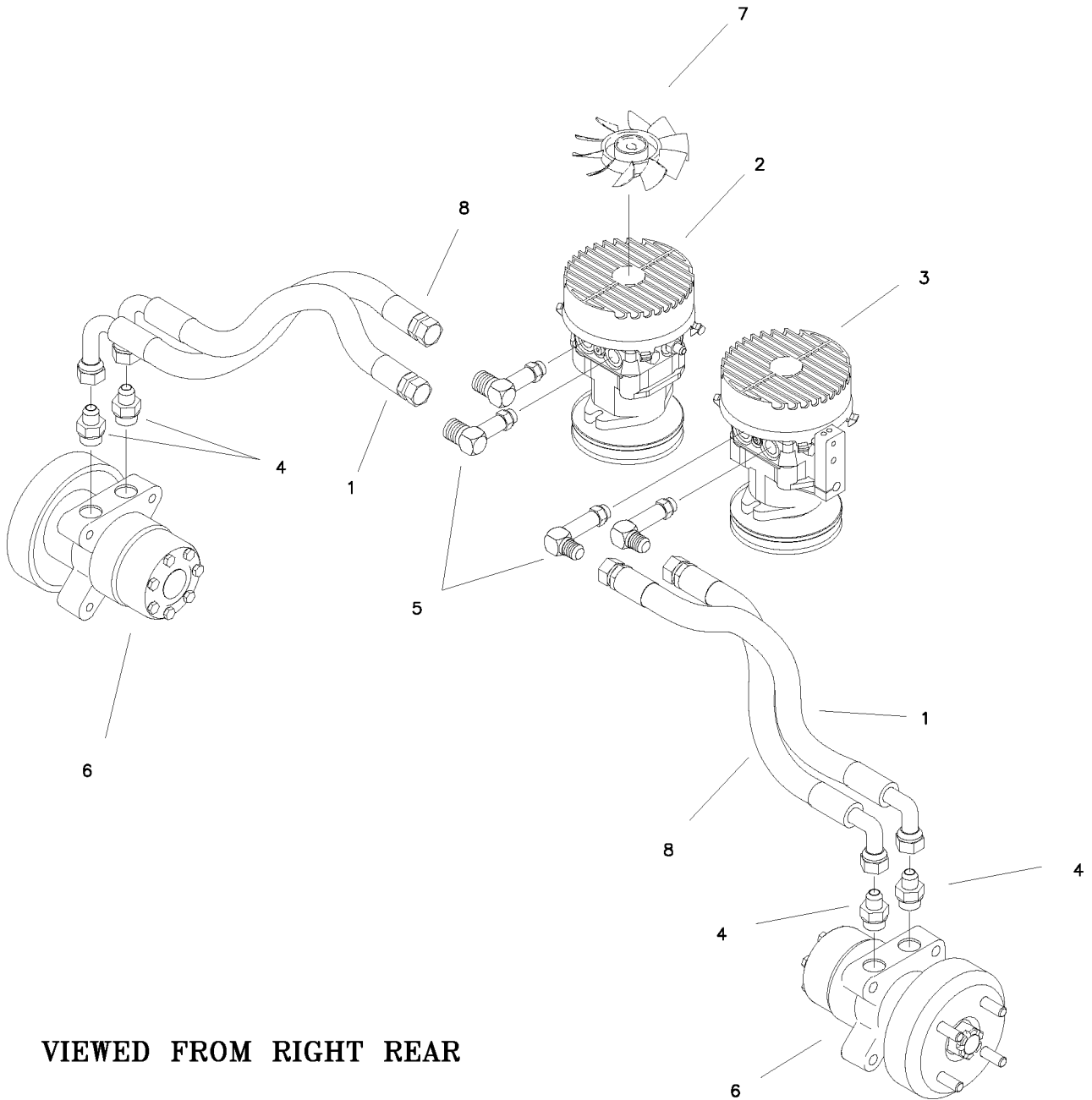

VIEWED FROM RIGHT REAR

REF NO.	PART NO.	QTY.	DESCRIPTION
1	H-2492	2	HOSE ASS'Y. 16-1/2"
2	D-3780-01	1	HYDRO PUMP, 12CC LH
3	D-3780-02	1	HYDRO PUMP, 12CC RH
4	H-2436	4	FITTING, STRAIGHT
5	H-2496	4	FITTING, 90°
6	-	2	SEE PAGE 25
7	D-3804	2	REPLACEMENT FAN BLADE
8	H-2576	2	HOSE ASS'Y. 11"

H-2574 PLUMBING KIT

HIGH PRESSURE LINES & FITTINGS

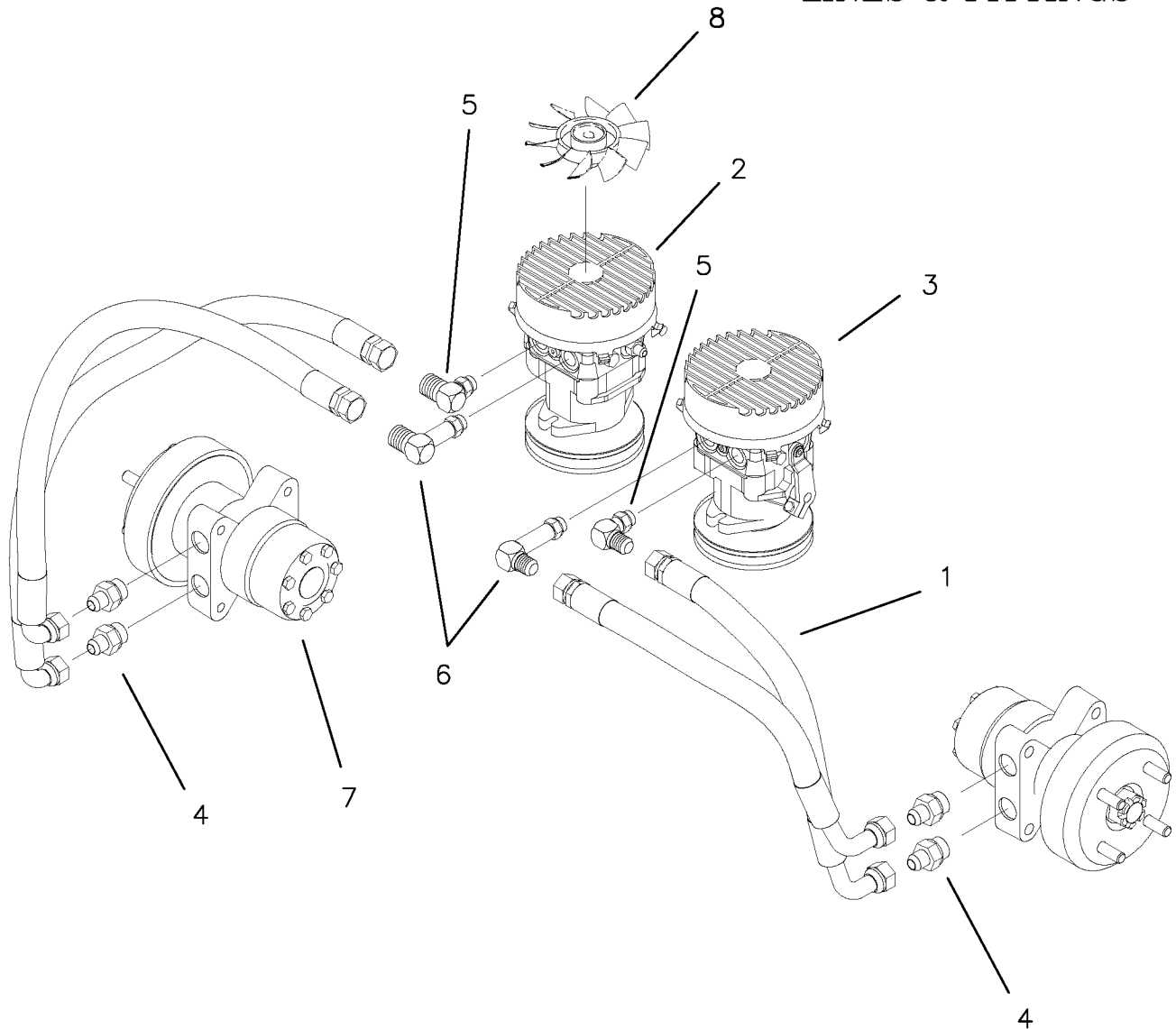

VIEWED FROM RIGHT REAR

REF NO.	PART NO.	QTY.	DESCRIPTION
1	H-2492	4	HOSE ASS'Y.
2	D-3780-01	1	HYDRO PUMP, 12CC LH
3	D-3780-02	1	HYDRO PUMP, 12CC RH
4	H-2436	4	FITTING, STRAIGHT
5	H-2495	2	FITTING, 90°
6	H-2496	2	FITTING, 90°
7	----	-	SEE PAGE 25
8	D-3804	2	REPLACEMENT FAN BLADE

H-2559 PLUMBING KIT

MOTOR ASSEMBLY & RELATED PARTS

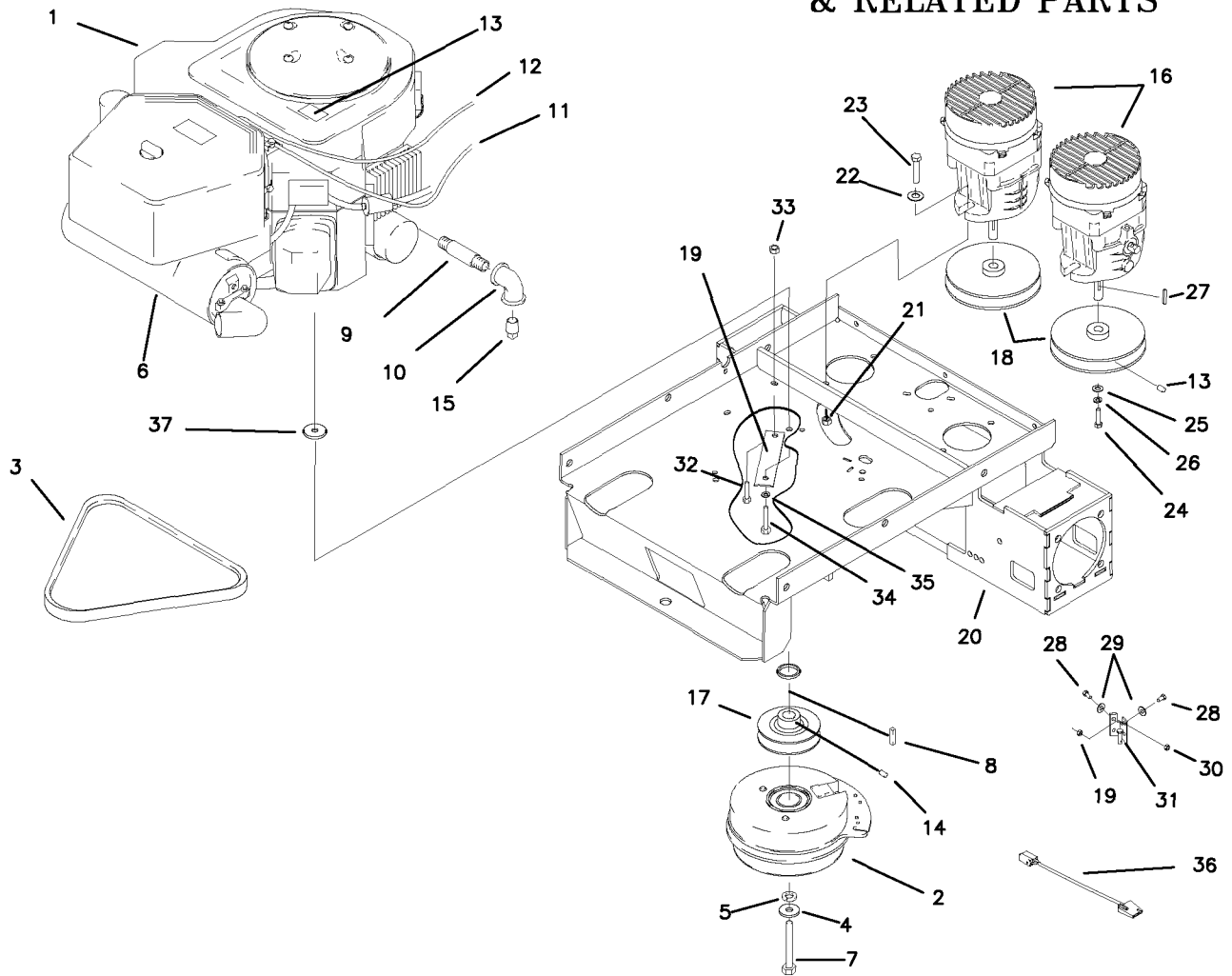

REF NO.	PART NO.	QTY.	DESCRIPTION	REF NO.	PART NO.	QTY.	DESCRIPTION
1	ENGINE	1	SEE PAGE 30	18	647-147P	2	HYDRO PUMP PULLEY
2	CLUTCH	1	SEE PAGE 30	19	647-085P	1	GROUND STRAP
3	D-3799	1	HYDRO PUMP BELT	20	647-188W	1	MOTOR MOUNT
4	606-347P	1	WASHER	21	F-1005-03	8	NUT, 3/8-16 STOVER
5	F-1019-04	1	7/16 LOCK WASHER	22	F-1009-03	4	3/8 FLAT WASHER
6	MUFFLER	1	SEE PAGE 30	23	F-1307	4	3/8-16 X 1-1/4" GR. 5
7	BOLT	1	SEE PAGE 30	24	F-1737	2	6MM X 16MM GR. 5
8	621-113P	1	KEY, 1/4 SQ. X 1-1/4"	25	F-1738	2	6MM WASHER
9	H-1082	1	3/8 X 2" PIPE NIPPLE	26	F-1736	2	LOCK WASHER
-	H-1089	1	3/8 X 2-1/2" PIPE NIPPLE	27	D-3541	2	KEY, 5MM.
-	H-1451	1	3/8 X 3" PIPE NIPPLE	28	F-1015-02	2	1/4-20 X 5/8" BOLT GR. 5
10	H-1218	1	3/8" PIPE ELBOW	29	F-1009-01	2	1/4" FLAT WASHER
11	SEE PG. 30	1	CHOKE CABLE	30	F-1158	2	1/4-20 STOVER NUT
12	SEE PG. 30	1	THROTTLE CABLE	31	659-015W	1	CLUTCH STOP WELDMENT
13	P-10077	1	DECAL, "CLEAN"	32	F-1015-15	1	5/16-18 X 1" BOLT
14	F-1228	3	SETSCREW, 1/4" X 1/4"	33	F-1125	-	5/16-18 STOVER NUT
15	H-1380	1	PLUG, 3/8" NPT	34	BOLT	-	SEE PAGE 30
16	HYD PUMP	2	SEE PAGE 28	35	F-1019-03	-	3/8 LOCK WASHER
17	647-148P	1	MOTOR PULLEY	36	E-6425	1	WIRE, FOR E-6425 CLUTCH
				37	609-034P	-	HEAVY 3/8" WASHER

ENGINE & CLUTCH MOUNTING HARDWARE

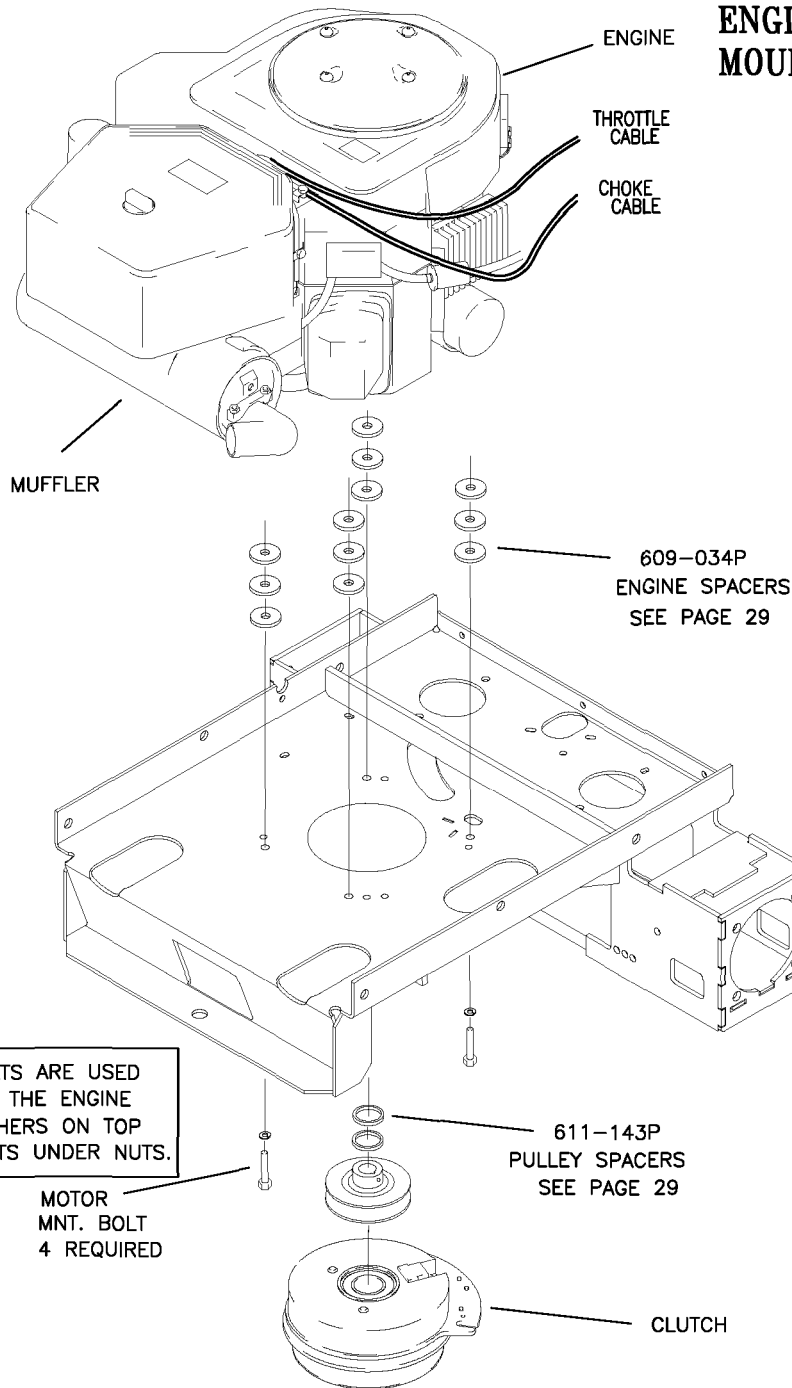

PART NO.	ENGINE	CLUTCH	MUFFLER	ENGINE SPACERS	PULLEY SPACERS	MOTOR MOUNT BOLTS	CLUTCH BOLT	THROTTLE CABLE	CHOKE CABLE
M-5327	25 HP KAWASAKI	E-6444	H-2284	3	4	F-1015-28 3/8-16 X 1-3/4" G5 BOLTS	F-1904	H-2573	H-2287
M-5348	26 HP KAW. LQ.	E-6444	H-2474	0	0	F-1979 8MM X 1-1/4" BOLTS	F-1981	H-2573	H-2287
M-5335	27 HP KOHLER	E-6444	-	0	0	F-1015-17 5/16 X 1-1/2" G5 BOLT	F-1545	H-2573	H-2287
M-5365	28 HP KOH. EFI	E-6444	-	0	0	F-1015-17 5/16 X 1-1/2" G5 BOLT	F-1545	H-2573	H-2287
M-5364	31 HP KAWASAKI	E-6444	H-2578	4	5	F-1015-28 3/8-16 X 1-3/4" G5 BOLTS	F-1904	H-2573	H-2287
M-5360	37 HP KAWASAKI	E-6425	H-2544	0	0	F-1307 3/8-16 X 1-1/4" G5 BOLTS	F-1904	H-2565	H-2404

MOTOR TO PUMPS SINGLE IDLER & BELT TIGHTENER

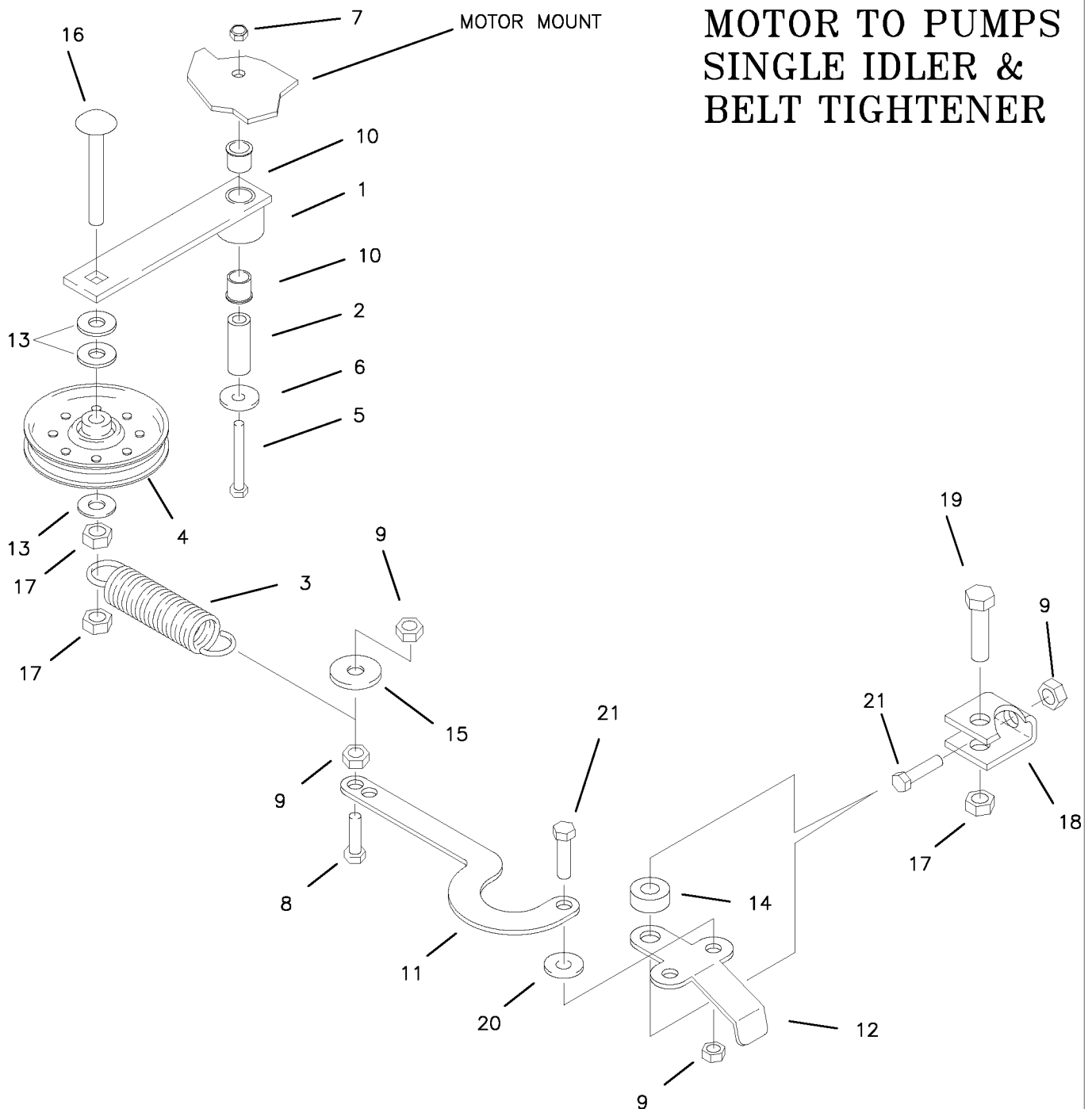

REF NO.	PART NO.	QTY.	DESCRIPTION	REF NO.	PART NO.	QTY.	DESCRIPTION
1	661-090A	1	SINGLE IDLER ASSEMBLY	12	660-030P	1	HANDLE, BELT TIGHTENER
-	661-060W	1	SINGLE IDLER WELDMENT	13	F-1521	3	1/2" FLAT WASHER
2	621-103P	1	MOUNTING PIN	14	660-038P	1	3/8" THICK SPACER
3	H-2092	1	SPRING	15	609-034P	1	HEAVY WASHER
4	D-3338	1	FLAT IDLER PULLEY	16	F-1822	1	1/2-13 X 2-1/4" CARRIAGE BOLT
5	F-1820	1	5/16-18 X 2-1/4" HHCS GR. 5	17	F-1005-05	3	1/2" LOCK NUT
6	F-1009-02	1	5/16" FLAT WASHER	18	661-015P	1	SHACKLE
7	F-1125	1	5/16" LOCK NUT	19	F-1526	1	1/2-13 X 1-1/2" BOLT
8	F-1307	1	3/8-16 X 1-1/4" HHCS GR. 5	20	F-1009-03	1	3/8" FLAT WASHER
9	F-1005-03	4	3/8-16 LOCK NUT	21	F-1694	2	3/8-16 X 1" HHCS GR. 5
10	D-3730	2	5/8 BORE BUSHING				
11	660-031P	1	ARM, BELT TIGHTENER				

BATTERY BOX & RELATED PARTS

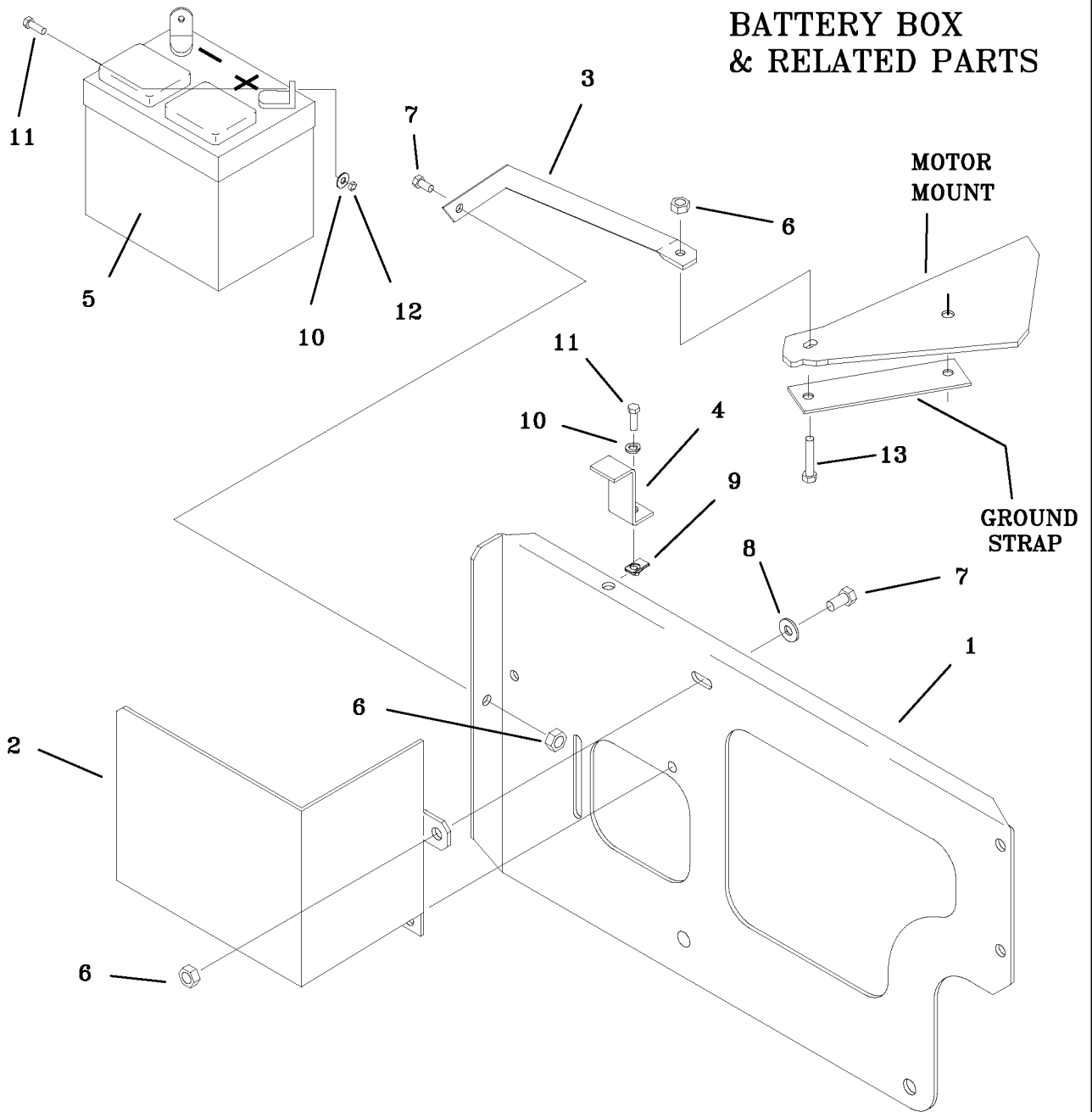

REF NO.	PART NO.	QTY.	DESCRIPTION
1	647-137	1	LH ENGINE GUARD
2	647-135P	1	BATTERY BOX
3	647-138P	1	BRACE
4	647-039P	1	BATTERY HOLD DOWN
5	E-6271	1	BATTERY
6	F-1125	5	5/16 LOCK NUT
7	F-1015-15	4	5/16-18 X 1" BOLT
8	F-1009-02	1	5/16 FLAT WASHER
9	F-1858	1	1/4" U-NUT
10	F-1019-01	3	1/4" LOCK WASHER
11	F-1538	3	1/4-20 X 3/4" BOLT
12	F-1158	2	1/4" LOCK NUT
13	F-1879	1	1/4-20 X 1-1/4" BOLT

OIL RETURN LINES & COOLER ASSEMBLY

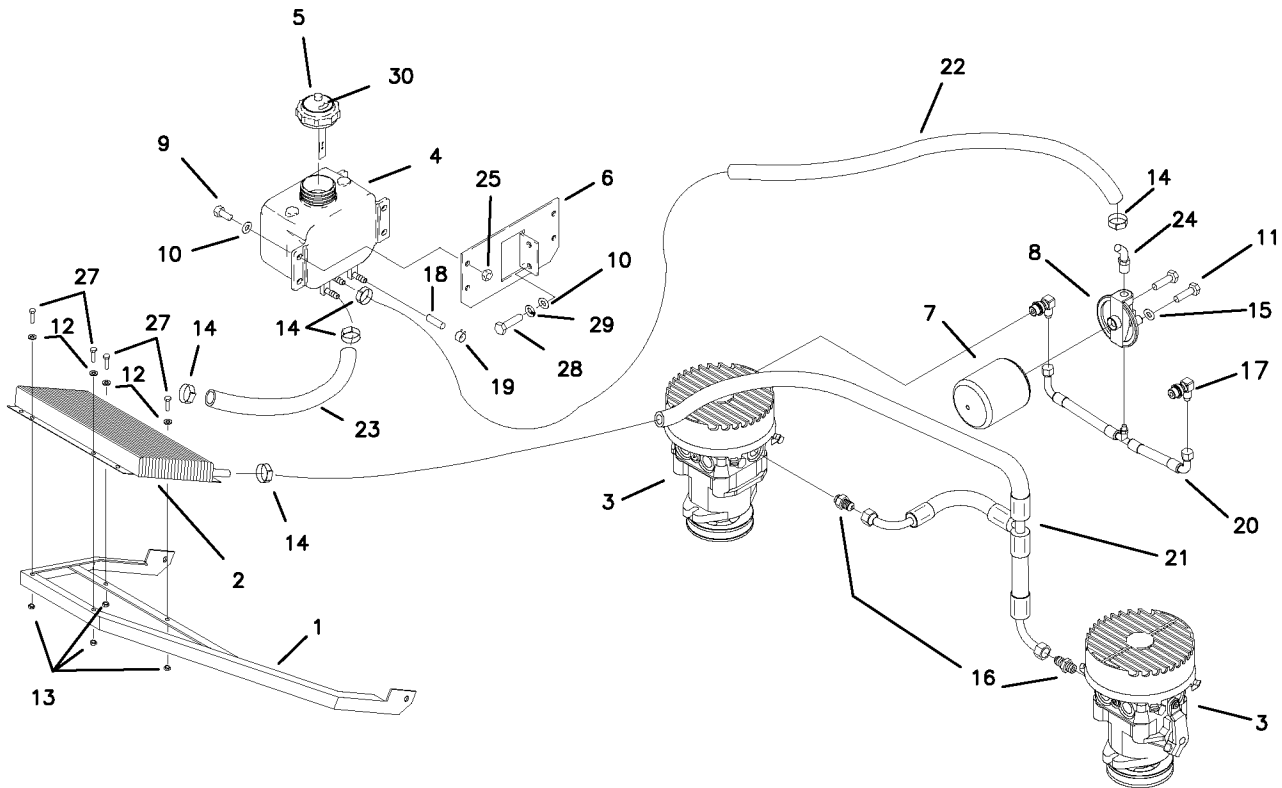

REF NO.	PART NO.	QTY.	DESCRIPTION	REF NO.	PART NO.	QTY.	DESCRIPTION
1	647-046W	1	BRACKET, OIL COOLER	16	H-2330	3	ADAPTER
2	H-2325	1	OIL COOLER	17	H-2331	2	ELBOW
3	-	-	SEE PAGE 3-20	18	H-2327	1	CAPLUG, 3/8 X 1"
4	H-2230	1	TANK, 2 QUART	19	H-1687	1	HOSE CLAMP
5	H-2120	1	CAP, HYDRO TANK	20	H-2479	1	HOSE, SUCTION
6	642-052P	1	TANK MOUNT BRACKET	21	H-2480	1	HOSE, RETURN
7	H-2026	1	FILTER, HYDRO	22	H-2438	1	HOSE, 24" HI-TEMP
8	H-2061	1	FILTER BASE	23	H-2478	1	HOSE, 18" HI-TEMP
9	F-1546	4	5/16 X 3/4 GR. 5	24	H-1859	1	1/4 PIPE & HOSE BARB 90°
10	F-1009-02	6	5/16 FLAT WASHER	25	F-1125	4	5/16-18 STOVER NUT
11	F-1015-05	2	1/4-20 X 1" GR. 5	26	F-1019-02	2	5/16- LOCK WASHER
12	F-1009-01	4	1/4" FLAT WASHER	27	F-1538	4	1/4-20 X 3/4" GR. 5
13	F-1158	4	1/4" LOCK NUT	28	F-1394	2	3/8-16 X 1" CAPSCREW
14	H-2282	5	HOSE CLAMP	29	F-1019-03	2	3/8 LOCKWASHER
15	F-1019-01	2	LOCK WASHER	30	P-11383	1	DECAL, OIL

WIRE HARNESS

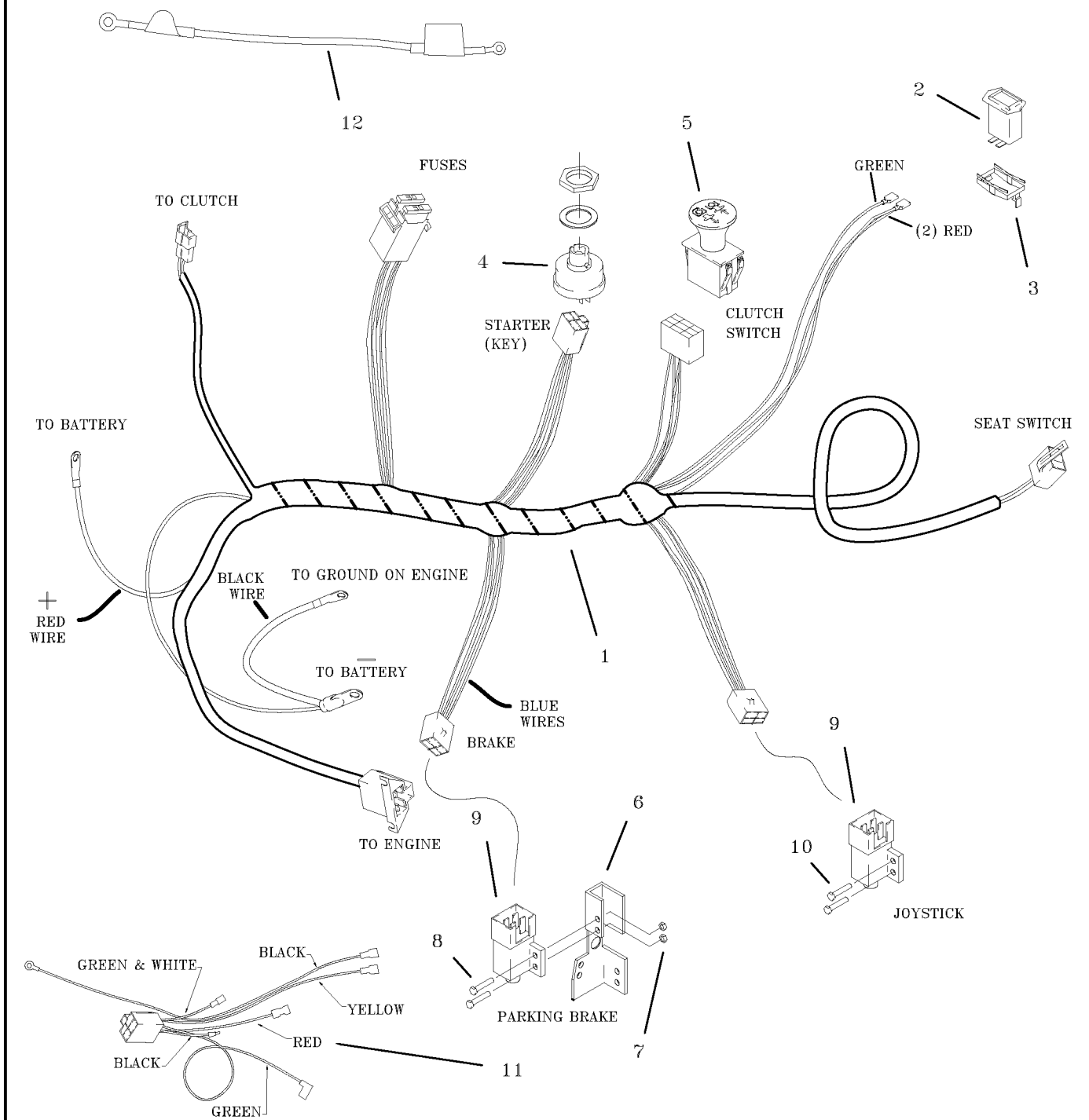

REF NO.	PART NO.	QTY.	DESCRIPTION	REF NO.	PART NO.	QTY.	DESCRIPTION
1	E-6437	1	WIRE HARNESS, JOYSTICK, KOHLER	10	F-1993	2	10-32 X 5/8" THD FORM SCREW
-	E-6437	1	WIRE HARNESS, EFI	11	E-6417	1	KOHLER TO KAWASAKI ADAPTER
2	E-5878	1	HOUR METER	12	E-6418	1	WIRE, BATTERY TO STARTER
3	E-6369	1	RETAINER CLIP				
4	E-5873	1	START SWITCH				
5	E-6403	1	CLUTCH SWITCH				
6	642-054P	1	BRAKE SWITCH BRACKET				
7	F-1448	2	8-32 LOCK NUT				
8	F-1022-26	2	8-32 X 5/8 SCREW				
9	E-6297	2	PLUNGER SWITCH, JOYSTICK				

TWINSTICK WIRE HARNESS

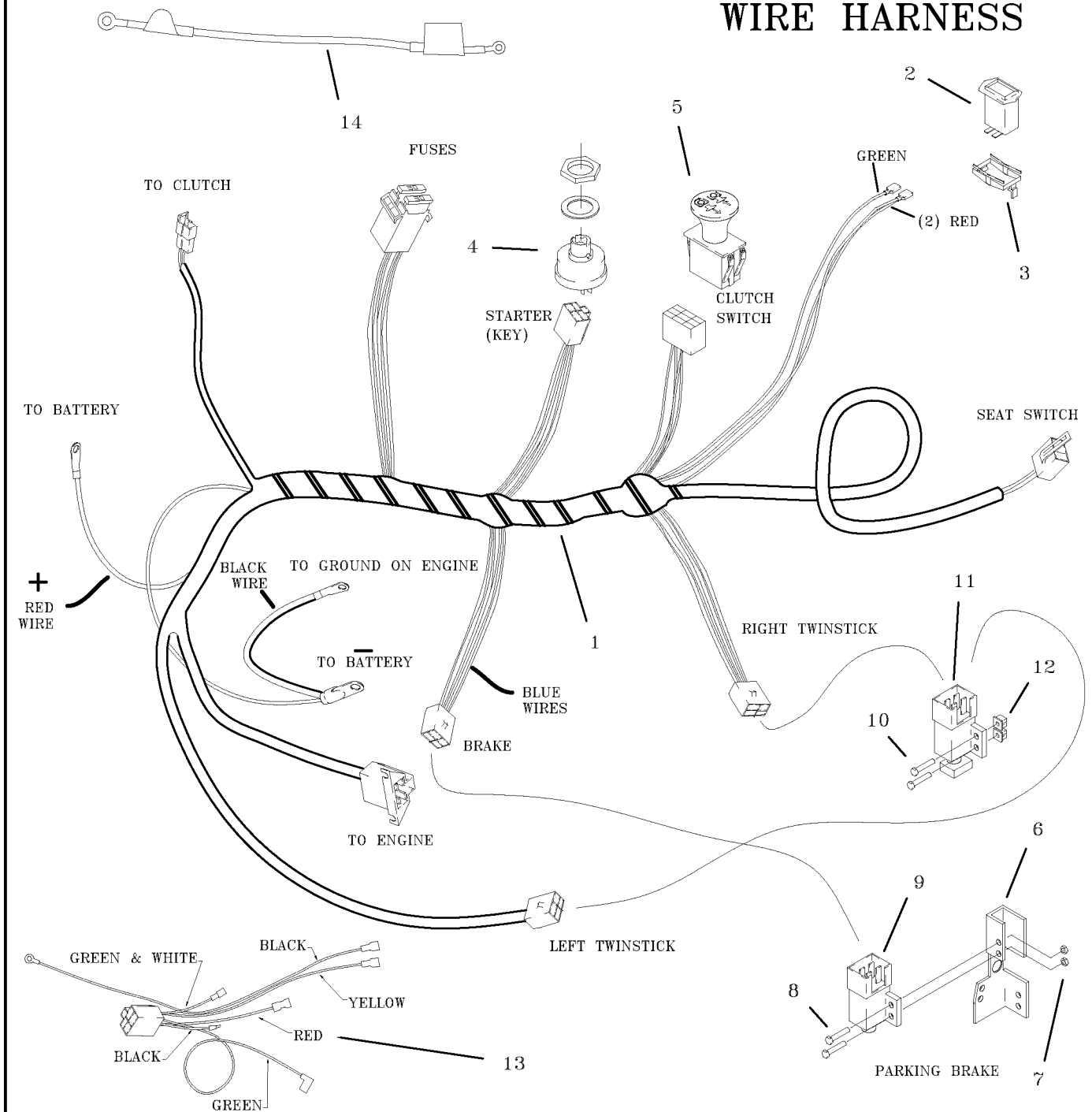

REF NO.	PART NO.	QTY.	DESCRIPTION	REF NO.	PART NO.	QTY.	DESCRIPTION
1	E-6438	1	WIRE HARNESS, KOHLER	10	F-1994	4	#10 X 5/8" SCREW,
2	E-5878	1	HOUR METER	11	647-112A	2	SWITCH BLOCK ASS'Y.
3	E-6369	1	RETAINER CLIP	12	F-1995	4	GROMMET, #10
4	E-5873	1	START SWITCH	13	E-6417	1	KOHLER TO KAWASAKI ADAPTER
5	E-6403	1	CLUTCH SWITCH	14	E-6418	1	WIRE, BATTERY TO STARTER
6	642-054P	1	BRAKE SWITCH BRACKET				
7	F-1448	2	8-32 LOCK NUT				
8	F-1022-26	2	8-32 X 5/8 SCREW				
9	E-6297	2	PLUNGER SWITCH,				

EFI WIRE HARNESS

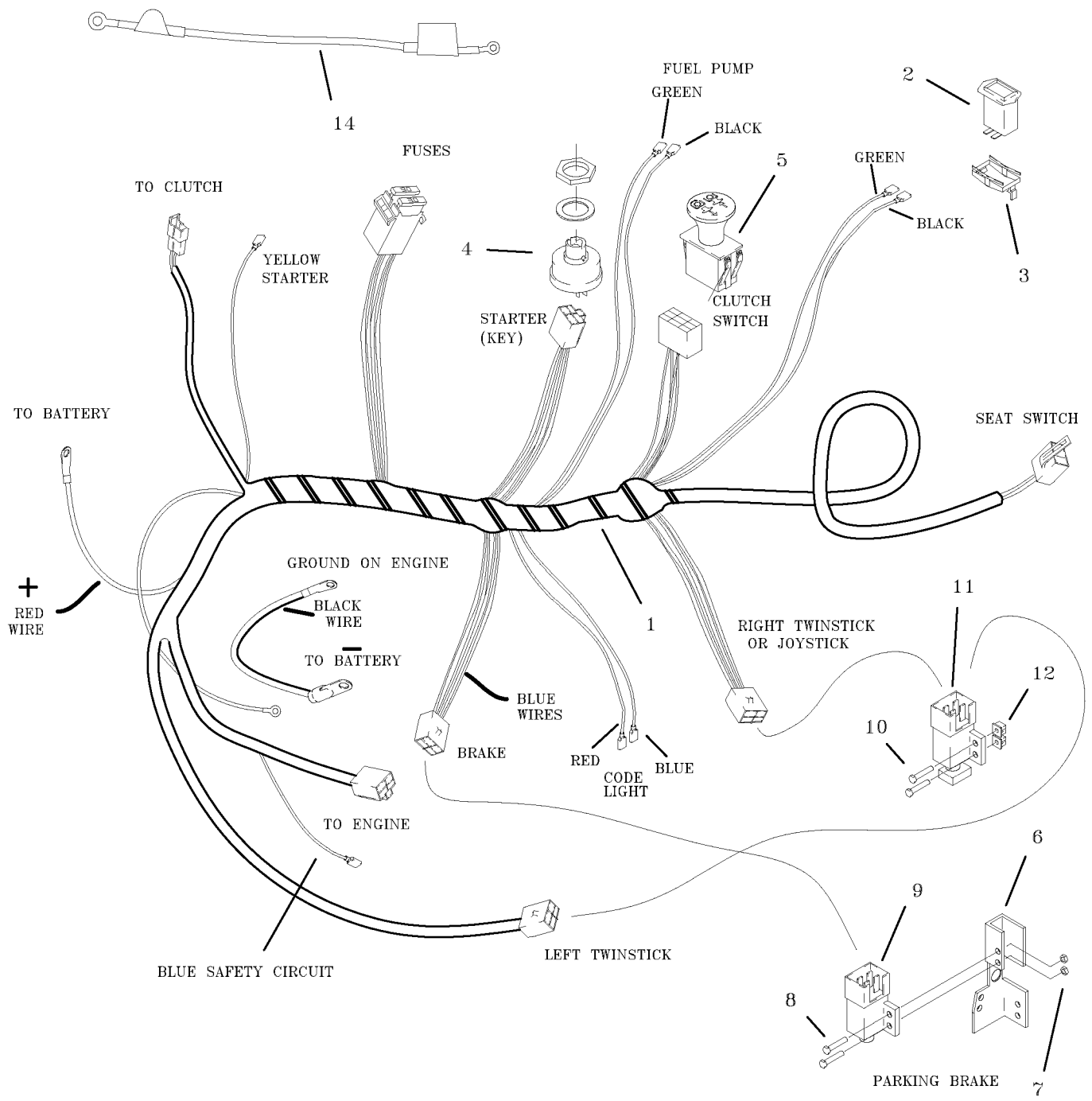

REF NO.	PART NO.	QTY.	DESCRIPTION	REF NO.	PART NO.	QTY.	DESCRIPTION
1	E-6450	1	WIRE HARNESS, KOHLER	10	F-1994	4	#10 X 5/8" SCREW,
2	E-5878	1	HOUR METER	11	647-112A	2	SWITCH BLOCK ASS'Y.
3	E-6369	1	RETAINER CLIP	12	F-1995	4	GROMMET, #10
4	E-5873	1	START SWITCH				
5	E-6403	1	CLUTCH SWITCH	14	E-6418	1	WIRE, BATTERY TO STARTER
6	642-054P	1	BRAKE SWITCH BRACKET				
7	F-1448	2	8-32 LOCK NUT				
8	F-1022-26	2	8-32 X 5/8 SCREW				
9	E-6297	2	PLUNGER SWITCH,				