

COUNTRY CLIPPER "ZETON" MOWER REPAIR PARTS MANUAL

COUNTRY CLIPPER "ZETON" & "ZETON BOSS" ZERO TURN RADIUS MOWER

TABLE OF CONTENTS

PAGE.... CONTENTS

SECTION 1 – MOWER DECKS AND RELATED PARTS

- 1-1.52" DECK ASSEMBLY
- 1-2-A. . .60" DECK ASSEMBLY
- 1-2-B. . .72" DECK ASSEMBLY
- 1-3. . . .DECK SPINDLE ASSEMBLY
- 1-4. . . .DRIVE BELT IDLER & RELATED PARTS
- 1-5. . . .LIFT HANDLE ASSEMBLY & RELATED PARTS
- 1-6-A. . .LIFT ASSEMBLY & RELATED PARTS
- 1-6-B. . .LIFT ASSEMBLY AND RELATED PARTS (ZETON BOSS)
- 1-7. . . .DOUBLE IDLER & RELATED PARTS

SECTION 2 –TRACTOR FRAME AND RELATED PARTS

- 2-8.CASTER WHEEL ASSEMBLY
- 2-9.FRAME SIDES & RELATED PARTS
- 2-10. . . .FENDER ASSEMBLY
- 2-11. . . .SEAT, FOOT DECK & RELATED PARTS

SECTION 3 –TRACTOR DRIVE AND RELATED PARTS

- 3-12. . . .DECK FLIP/TIRE JACK & FUEL TANK ASSEMBLY
- 3-13. . . .JOYSTICK STEERING CONTROL & RELATED PARTS
- 3-14. . . .JOYSTICK STEERING CONTROL & RELATED PARTS (continued)
- 3-15. . . .RIGHT HAND STEERING CONTROL & RELATED PARTS
- 3-16. . . .LEFT HAND STEERING CONTROL & RELATED PARTS
- 3-17. . . .PARKING BRAKE ASSEMBLY & RELATED PARTS
- 3-18. . . .GEAR MOTOR WHEEL ASSEMBLY
- 3-19. . . .MOTOR ASSEMBLY & RELATED PARTS
- 3-20. . . .HIGH PRESSURE LINES & FITTINGS
- 3-21. . . .OIL RETURN LINES & COOLER ASSEMBLY
- 3-22. . . .MOTOR TO PUMP SINGLE IDLER
- 3-23. . . .WIRE HARNESS & RELATED PARTS
- 3-24. . . .WIRE HARNESS & RELATED PARTS FOR FUEL INJECTED ENGINE
- 3-25. . . .FUEL INJECTION FUEL LINE ASSEMBLY

COUNTRY CLIPPER "ZETON" MOWER REPAIR PARTS MANUAL

52" DECK ASSEMBLY

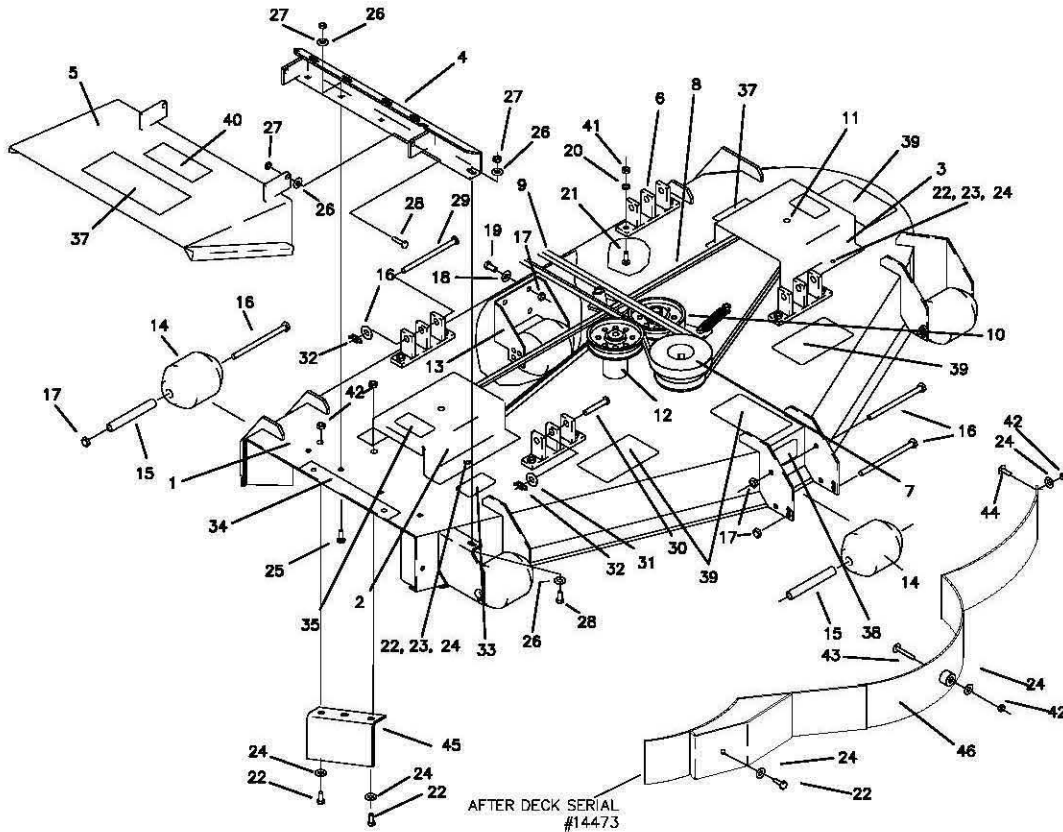

| REF NO. | PART NO. | QTY. | DESCRIPTION |
|---------|-----------|------|--|
| 1 | 643-033A | 1 | 52" DECK W/DECALS |
| | 643-040A | 1 | 52" FRONT BAFFLE DECK W/DECALS |
| 2 | 643-034A | 1 | PULLEY COVER RH, W/DECAL |
| 3 | 643-035A | 1 | PULLEY COVER LH, W/DECAL |
| 4 | 637-053W | 1 | OUTLET STIFFENER |
| 5 | 637-062A | 1 | 60" DECK CHUTE W/DECAL |
| 6 | 643-016W | 4 | DECK HANGER |
| 7 | 609D-156P | 1 | PULLEY, 5-3/4 DIA. 2 GROOVE |
| 8 | D-3635 | 1 | V-BELT (KEVLAR) A-100 |
| 9 | D-3645 | 1 | V-BELT, MOTOR TO DECK |
| 10 | ----- | 1 | SINGLE IDLER ASSEMBLY (SEE BREAK-DOWN PAGE) |
| 11 | ----- | 1 | SPINDLE ASSEMBLY (SEE BREAK-DOWN PAGE) |
| 12 | ----- | 1 | DRIVE BELT IDLER (SEE BREAK-DOWN PAGE) |
| 13 | 609-182P | 1 | REAR SCALPER BRACKET |
| 14 | H-1948 | 6 | ROLLER, 3-3/4 DIA. X 4-13/16 |
| 15 | 609-183P | 6 | WHEEL BUSHING |
| 16 | F-1741 | 7 | 3/8-16 X 6" GR. 5 |
| 17 | F-1239 | 11 | 3/8 LOCKNUT |
| 18 | F-1009-03 | 4 | 3/8 FLAT WASHER |
| 19 | F-1558 | 4 | 3/8-16 X 7/8 GR. 5 |
| 20 | F-1019-03 | 8 | 3/8" LOCKWASHER |

| REF NO. | PART NO. | QTY. | DESCRIPTION |
|---------|-----------|------|-------------------------------|
| 21 | F-1672 | 8 | CARRIAGE BOLT, 5/16 X 1-1/4 |
| 22 | F-1538 | 7 | 1/4-20 X 3/4 GR. 5 |
| 23 | F-1019-01 | 4 | 1/4" LOCKWASHER |
| 24 | F-1009-01 | 9 | 1/4" FLAT WASHER |
| 25 | F-1671 | 4 | CARRIAGE BOLT 5/16 X 3/4 |
| 26 | F-1009-02 | 8 | 5/16" FLAT WASHER |
| 27 | F-1125 | 7 | 5/16-18 LOCKNUT |
| 28 | F-1015-15 | 3 | 5/16-18 X 1" GR. 5 |
| 29 | H-2240 | 2 | PIN, 1/2" X 4-1/2" |
| 30 | F-1889 | 2 | PIN, 1/2" X 2-1/2" |
| 31 | F-1521 | 4 | 1/2" FLAT WASHER |
| 32 | H-2239 | 4 | RUE RING 1/2" |
| 33 | P-10947 | 1 | DECAL, "GREASE SPINDLE" |
| 34 | P-10122 | 1 | DECAL, "MISSING CHUTE" |
| 35 | P-10935 | 2 | DECAL, "ROTATING..." |
| 36 | ---- | - | ----- |
| 37 | P-10941 | 2 | DECAL, "MULTI PERIL" |
| 38 | P-11413 | 1 | DECAL, "HOIST POINT" |
| 39 | H-1932 | 4 | SAFETY TREAD |
| 40 | P-10937 | 1 | DECAL, "WARNING" |
| 41 | F-1005-03 | 8 | LOCKNUT, 3/8 STOVER |
| 42 | F-1158 | 4 | LOCKNUT, 1/4-20 |
| 43 | F-1935 | 1 | 1/4-20 X 1 1/2" CARRIAGE BOLT |
| 44 | F-1823 | 1 | 1/4-20 X 3/4" CARRIAGE BOLT |
| 45 | 629-230P | 1 | AIR BAFFLE |
| 46 | 629-229W | 1 | DUST BAFFLE WLDT, 52" |

COUNTRY CLIPPER "ZETON" MOWER REPAIR PARTS MANUAL

60" DECK ASSEMBLY

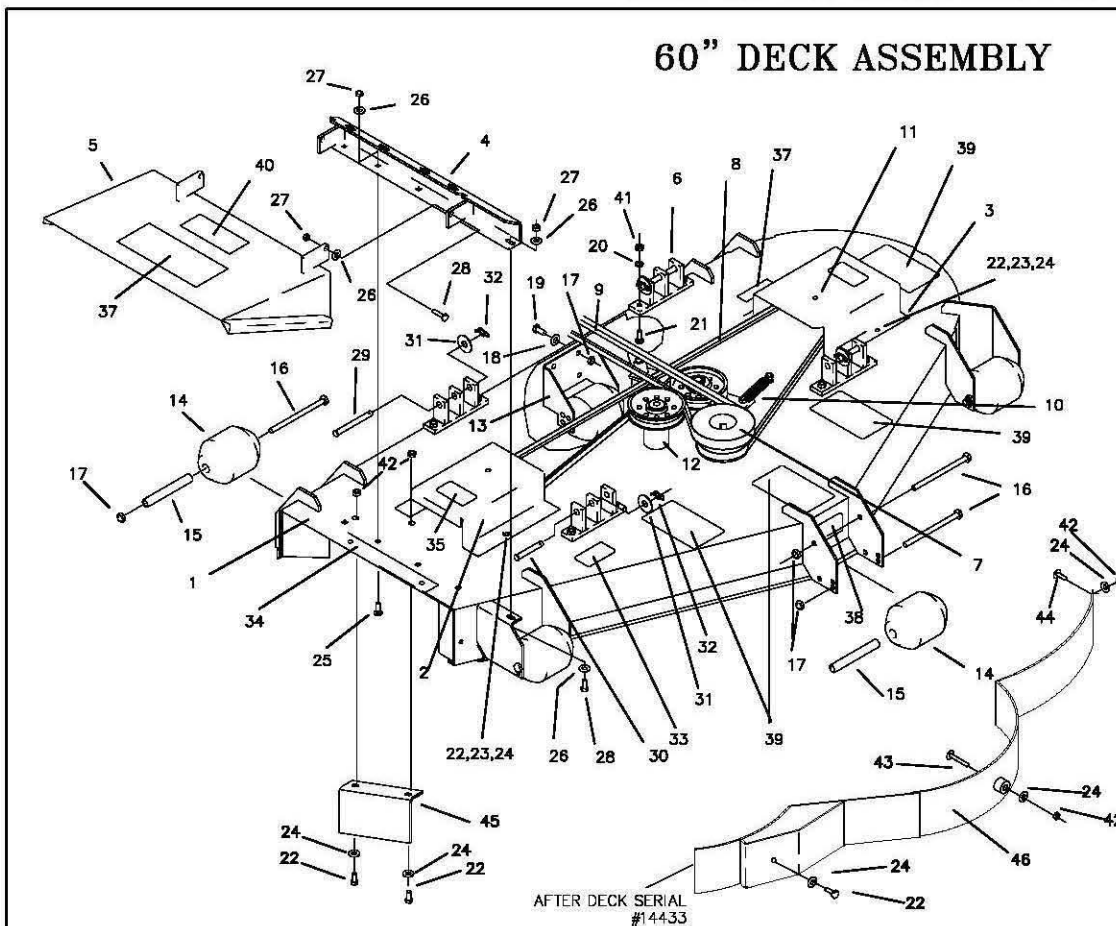

| REF NO. | PART NO. | QTY. | DESCRIPTION |
|---------|-----------|------|--|
| 1 | 643-036A | 1 | 60" DECK W/DECALS |
| | 643-059A | 1 | 60" FRONT BAFFLE DECK W/DECALS |
| 2 | 643-037A | 1 | PULLEY COVER RH, W/DECAL |
| 3 | 643-038A | 1 | PULLEY COVER LH, W/DECAL |
| 4 | 637-053W | 1 | OUTLET STIFFENER |
| 5 | 637-062A | 1 | 60" DECK CHUTE W/DECAL |
| 6 | 643-016W | 4 | DECK HANGER |
| 7 | 609C-156P | 1 | PULLEY, 5-3/8DIA. 2 GROOVE |
| 8 | D-3389 | 1 | V-BELT (KEVLAR) A-112 |
| 9 | D-3645 | 1 | V-BELT, MOTOR TO DECK |
| 10 | ----- | 1 | SINGLE IDLER ASSEMBLY (SEE BREAK-DOWN PAGE) |
| 11 | ----- | 1 | SPINDLE ASSEMBLY (SEE BREAK-DOWN PAGE) |
| 12 | ----- | 1 | DRIVE BELT IDLER (SEE BREAK-DOWN PAGE) |
| 13 | 609-182P | 1 | REAR SCALPER BRACKET |
| 14 | H-1948 | 6 | ROLLER, 3-3/4 DIA. X 4-13/16 |
| 15 | 609-183P | 6 | WHEEL BUSHING |
| 16 | F-1741 | 7 | 3/8-16 X 6" GR. 5 |
| 17 | F-1239 | 11 | 3/8 LOCKNUT |
| 18 | F-1009-03 | 4 | 3/8 FLAT WASHER |
| 19 | F-1558 | 4 | 3/8-16 X 7/8 GR. 5 |
| 20 | F-1019-03 | 8 | 3/8" LOCKWASHER |
| 21 | F-1872 | 8 | CARRIAGE BOLT, 5/16 X 1-1/4 |

| REF NO. | PART NO. | QTY. | DESCRIPTION |
|---------|-----------|-------|-------------------------------|
| 22 | F-1538 | 7 | 1/4-20 X 3/4 GR. 5 |
| 23 | F-1019-01 | 4 | 1/4" LOCKWASHER |
| 24 | F-1009-01 | 9 | 1/4" FLAT WASHER |
| 25 | F-1671 | 4 | CARRIAGE BOLT 5/16 X 3/4 |
| 26 | F-1009-02 | 8 | 5/16" FLAT WASHER |
| 27 | F-1125 | 7 | 5/16-18 LOCKNUT |
| 28 | F-1015-15 | 3 | 5/16-18 X 1" GR. 5 |
| 29 | H-2240 | 2 | PIN, 1/2" X 4-1/2" |
| 30 | F-1889 | 2 | PIN, 1/2" X 2-1/2" |
| 31 | F-1521 | 4 | 1/2" FLAT WASHER |
| 32 | H-2239 | 4 | RUE RING 1/2" |
| 33 | P-10947 | 1 | DECAL, "GREASE SPINDLE" |
| 34 | P-10122 | 1 | DECAL, "MISSING CHUTE" |
| 35 | P-10935 | 2 | DECAL, "ROTATING..." |
| 36 | ----- | ----- | ----- |
| 37 | P-10941 | 2 | DECAL, "MULTI PERIL" |
| 38 | P-11413 | 1 | DECAL, "HOIST POINT" |
| 39 | H-1932 | 4 | SAFETY TREAD |
| 40 | P-10937 | 1 | DECAL, "WARNING" |
| 41 | F-1005-03 | 8 | LOCKNUT, 3/8 STOVER |
| 42 | F-1158 | 4 | LOCKNUT, 1/4-20 |
| 43 | F-1935 | 1 | 1/4-20 X 1 1/2" CARRIAGE BOLT |
| 44 | F-1823 | 1 | 1/4-20 X 3/4 CARRIAGE BOLT |
| 45 | 643-042P | 1 | AIR BAFFLE |
| 46 | 643-047W | 1 | DUST BAFFLE WLDT, 60" |

COUNTRY CLIPPER "ZETON" MOWER REPAIR PARTS MANUAL

72" DECK ASSEMBLY
DECK FOR ZETON BOSS

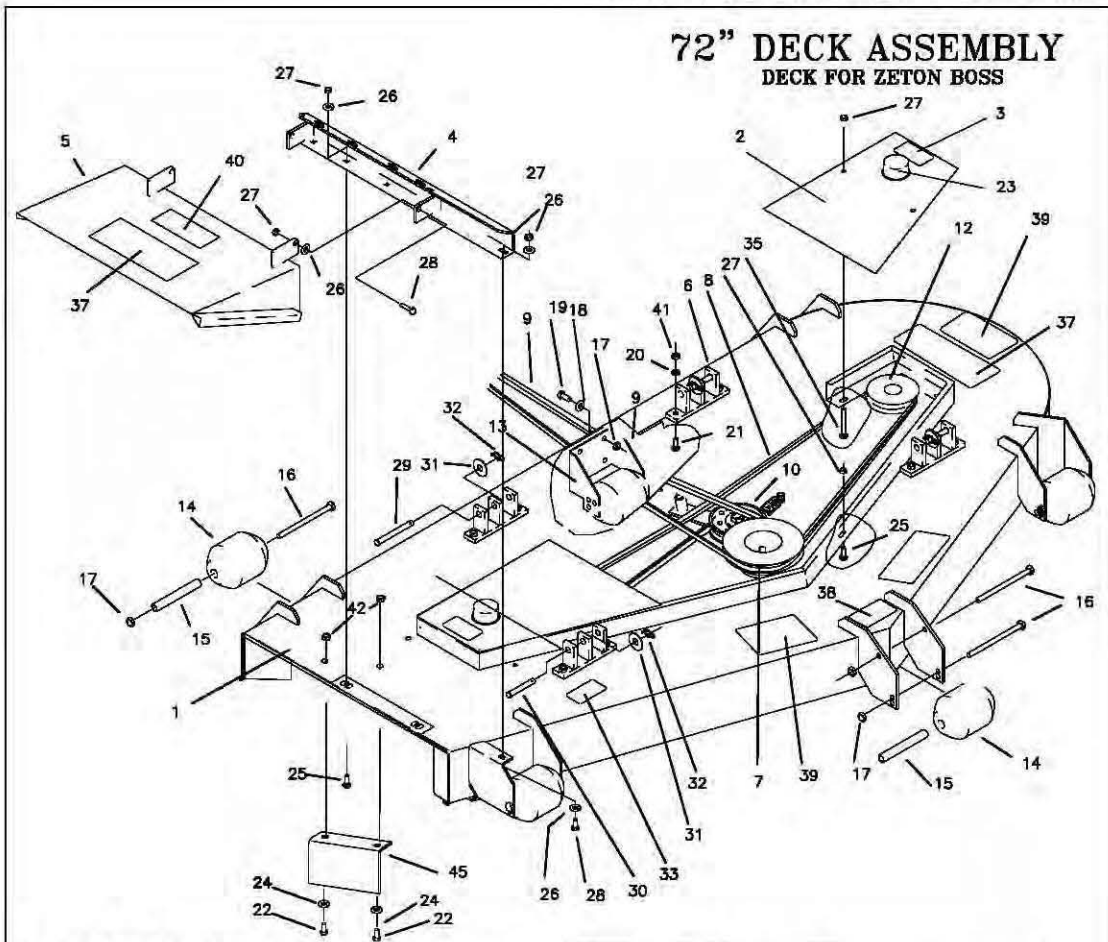

| REF NO. | PART NO. | QTY. | DESCRIPTION | REF NO. | PART NO. | QTY. | DESCRIPTION |
|---------|-----------|------|--|---------|-----------|------|-------------------------------|
| 1 | 643-069A | 1 | 72" DECK W/DECALS | 22 | F-1538 | 3 | 1/4-20 X 3/4 GR. 5 |
| 2 | 643-070A | 2 | PULLEY COVER, W/DECAL | 23 | H-1798 | 2 | GALVANIZED CAP |
| 3 | P-10935 | 2 | DECAL, "ROTATING..." | 24 | F-1009-01 | 5 | 1/4" FLAT WASHER |
| 4 | 643-051W | 1 | OUTLET STIFFENER | 25 | F-1871 | 20 | CARRIAGE BOLT 5/16 X 3/4 |
| 5 | 643-071A | 1 | 72" DECK CHUTE W/DECAL | 26 | F-1009-02 | 6 | 5/16" FLAT WASHER |
| 6 | 643-018W | 4 | DECK HANGER | 27 | F-1125 | 27 | 5/16-18 LOCKNUT |
| 7 | 643-067P | 1 | PULLEY, 6 1/4" DIA. 2 GROOVE | 28 | F-1015-15 | 3 | 5/16-18 X 1" GR. 5 |
| 8 | D-3724 | 1 | V-BELT (KEVLAR) AK-128 | 29 | H-2240 | 2 | PIN, 1/2" X 4-1/2" |
| 9 | D-3645 | 1 | V-BELT, MOTOR TO DECK, B-108 | 30 | F-1889 | 2 | PIN, 1/2" X 2-1/2" |
| 10 | ----- | 1 | SINGLE IDLER ASSEMBLY (SEE BREAK-DOWN PAGE) | 31 | F-1521 | 4 | 1/2" FLAT WASHER |
| 11 | ----- | 1 | SPINDLE ASSEMBLY (SEE BREAK-DOWN PAGE) | 32 | H-2239 | 4 | RUE RING 1/2" |
| 12 | 643-068P | 1 | TOP STIFFENER, 72" | 33 | P-10947 | 1 | DECAL, "GREASE SPINDLE" |
| 13 | 609-182P | 1 | REAR SCALPER BRACKET | 34 | P-10122 | 1 | DECAL, "MISSING CHUTE" |
| 14 | H-1948 | 6 | ROLLER, 3-3/4 DIA. X 4-13/16 | 35 | F-1707 | 4 | CARRIAGE BOLT, 5/16 X 2 1/4" |
| 15 | 609-183P | 8 | WHEEL BUSHING | 36 | ----- | - | ----- |
| 16 | F-1741 | 7 | 3/8-16 X 6" GR. 5 | 37 | P-10941 | 2 | DECAL, "MULTI PERIL" |
| 17 | F-1239 | 11 | 3/8 LOCKNUT | 38 | P-11413 | 1 | DECAL, "HOIST POINT" |
| 18 | F-1009-03 | 4 | 3/8 FLAT WASHER | 39 | H-1932 | 4 | SAFETY TREAD |
| 19 | F-1558 | 4 | 3/8-16 X 7/8 GR. 5 | 40 | P-10837 | 1 | DECAL, "WARNING" |
| 20 | F-1019-03 | 8 | 3/8" LOCKWASHER | 41 | F-1005-03 | 8 | LOCKNUT, 3/8 STOVER |
| 21 | F-1672 | 8 | CARRIAGE BOLT, 5/16 X 1-1/4 | 42 | F-1158 | 4 | LOCKNUT, 1/4-20 |
| | | | | 43 | F-1935 | 1 | 1/4-20 X 1 1/2" CARRIAGE BOLT |
| | | | | 44 | F-1823 | 1 | 1/4-20 X 3/4 CARRIAGE BOLT |
| | | | | 45 | 643-042P | 1 | AIR BAFFLE |

COUNTRY CLIPPER "ZETON" MOWER REPAIR PARTS MANUAL

DECK SPINDLE ASSEMBLY

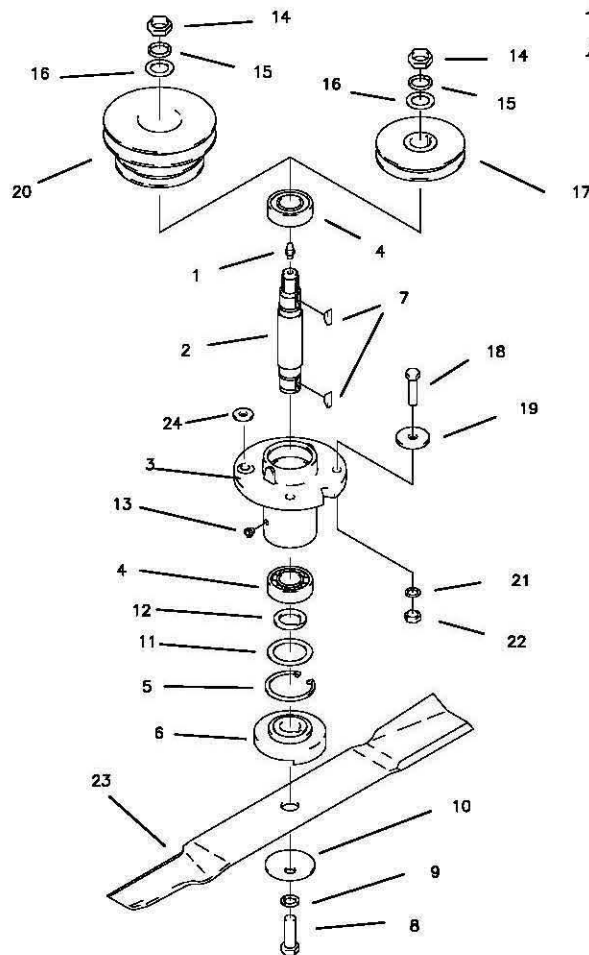

| REF NO. | PART NO. | QTY. | DESCRIPTION | REF NO. | PART NO. | QTY. | DESCRIPTION |
|---------|-----------|------|----------------------------|---------|-----------|------|-------------------------------|
| - | 609G-019A | - | SPINDLE ASSEMBLY | 16 | F-1510 | 1 | 3/4" WASHER, FLAT STD. |
| 1 | H-1056 | 1 | GREASE FITTING | 17 | 609-155P | - | PULLEY, 1 GROOVE 4" |
| 2 | 609-162P | 1 | SPINDLE SHAFT | 18 | F-1572 | 4 | 3/8-24 X 1-1/2" HHCS GR. 5 |
| 3 | 609-223P | 1 | SPINDLE HOUSING | 19 | 609-034P | 4 | SPINDLE SPACER REINFORCEMENT |
| 4 | D-3058 | 2 | BEARING, #6205-2RS | 20 | 609D-156P | 1 | PULLEY, 2 GROOVE 52" |
| 5 | H-1893 | 1 | SNAP RING INT. 52MM | - | 609C-156P | - | PULLEY, 2 GROOVE 60" |
| 6 | 609-152P | 1 | BLADE SPACER | - | 643-067P | - | PULLEY, 2 GROOVE 72" |
| 7 | D-1004-02 | 2 | KEY, WOODRUF, 1/4 X 3/4 | 21 | F-1019-03 | 4 | 3/8" LOCK WASHER |
| 8 | F-1526 | 1 | 1/2-13 X 1-1/2" HHCS GR. 5 | 22 | F-1573 | 4 | 3/8-24 LOCKNUT, M-F |
| 9 | F-1464 | 1 | 1/2" LOCK WASHER | 23 | H-2246 | 1 | BLADE, HIGH L, 18-3/8 CUT 52" |
| 10 | F-1507 | 1 | WASHER, 1/2" CUPPED | - | H-1667 | - | BLADE, LOW L, 21" CUT 60" |
| 11 | 609-151P | 1 | WASHER, SEAL | - | H-2397 | - | BLADE, LOW L, 25" CUT 72" |
| 12 | 609-073P | 1 | ARBOR SPACER | | | | OPTIONAL BLADES |
| 13 | H-2066 | 1 | GREASE VENT 5 LBS. | | H-1708 | - | BLADE, HIGH L, 21" CUT 60" |
| 14 | F-1461 | 1 | 3/4-16 NUT, HEX JAM | | H-2387 | - | BLADE, LW L, 18-3/8" CUT 52" |
| 15 | F-1463 | 1 | 3/4" LOCK WASHER | 23 | 629-237P | 2 | WASHER, .406 ID X 1" |

COUNTRY CLIPPER "ZETON" MOWER REPAIR PARTS MANUAL

DRIVE BELT IDLER &
RELATED PARTS

(NOT ON 72" DECK)

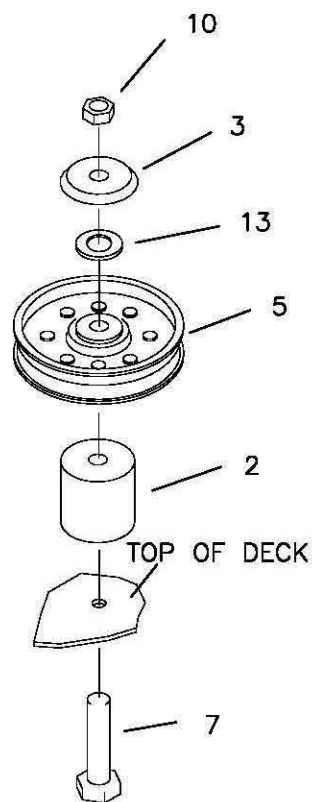
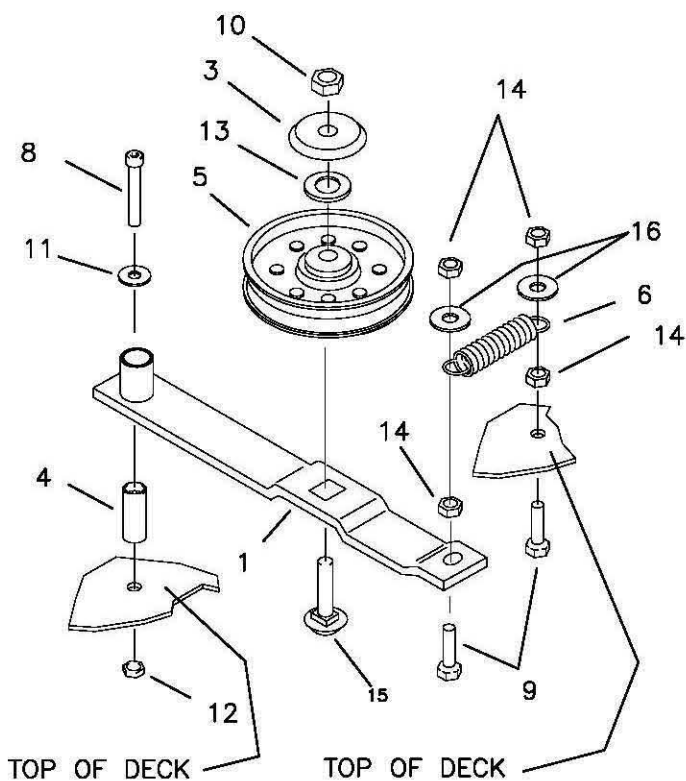
SINGLE IDLER ASSEMBLY &
RELATED PARTS

| REF NO. | PART NO. | QTY. | DESCRIPTION |
|---------|-----------|------|-----------------------------|
| 1 | 643-007W | 1 | SINGLE IDLER |
| 2 | 643-010P | 1 | PULLEY SPACER |
| 3 | 620-201P | 1 | BEARING CAP |
| 4 | 621-103P | 1 | PIN |
| 5 | D-3338 | 2 | PULLEY, FLAT IDLER |
| 6 | H-2092 | 1 | SPRING, 1-1/2" X 5" |
| 7 | F-1779 | 1 | 1/2-13 X 4" GR. 5 |
| 8 | F-1800 | 1 | 5/16-18 SHCS X 2-1/4" |
| 9 | F-1574 | 2 | 3/8-24 X 1-1/4" GR. 5 |
| 10 | F-1378 | 2 | 1/2-13 LOCKNUT |
| 11 | F-1009-02 | 1 | 5/16 FLAT WASHER |
| 12 | F-1125 | 1 | 5/16 LOCK NUT |
| 13 | F-1521 | 2 | 1/2" FLAT WASHER |
| 14 | F-1573 | 3 | 3/8" LOCK NUT |
| 15 | F-1822 | 1 | CARRIAGE BOLT, 1/2 X 2 1/4" |
| 16 | 809-034P | 2 | REINFORCEMENT WASHER |

COUNTRY CLIPPER "ZETON" MOWER REPAIR PARTS MANUAL

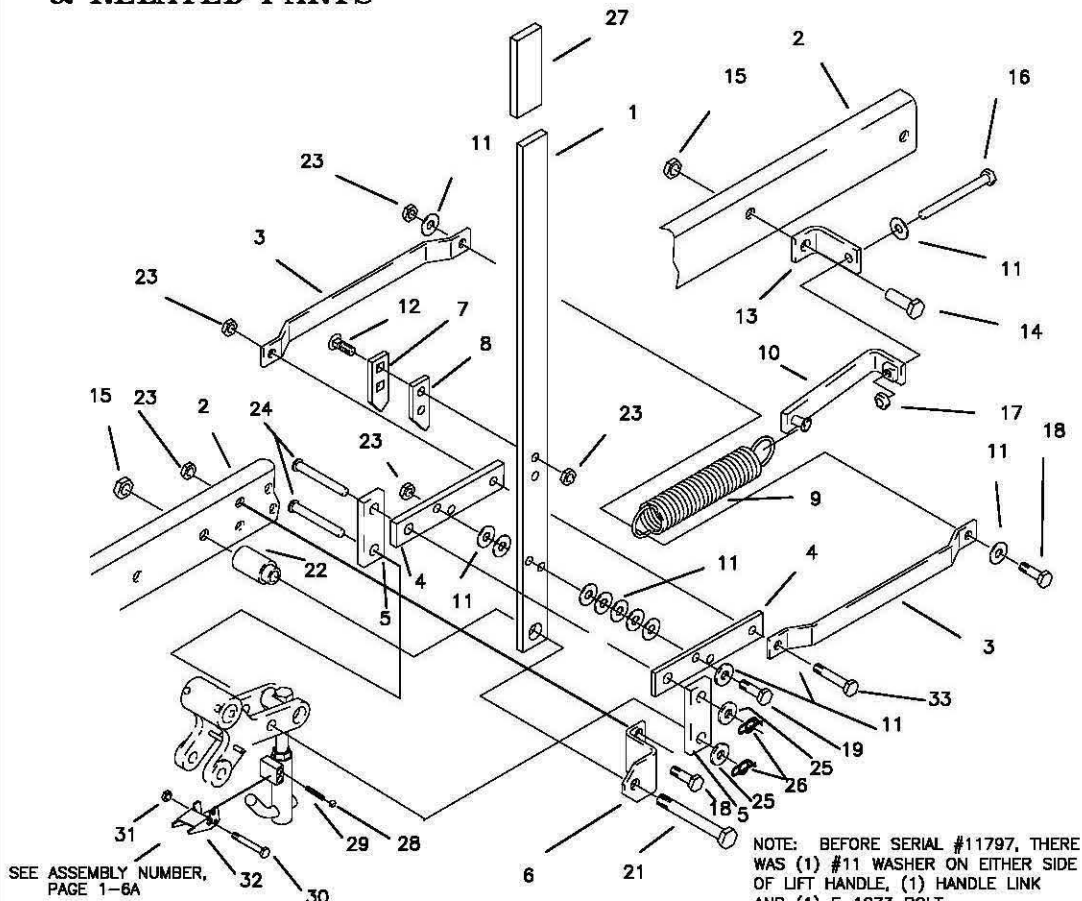
LIFT HANDLE ASSEMBLY
& RELATED PARTS

| REF NO. | PART NO. | QTY. | DESCRIPTION | REF NO. | PART NO. | QTY. | DESCRIPTION |
|---------|-----------|------|--------------------------------|---------|-----------|------|------------------------------|
| 1 | 642-062P | 1 | LIFT HANDLE | 21 | F-1828 | 1 | 1/2-13 X 3-1/2" GR. 5 |
| 2 | 642-040W | 1 | FRAME WELDMENT, LH. | 22 | 642-095P | 1 | HANDLE PIVOT PIN |
| 3 | 642-055P | 2 | SPRING EXTENSION | 23 | F-1005-03 | 7 | NUT, 3/8-16 LOCKNUT (STOVER) |
| 4 | 642-060P | 2 | SPRING ANCHOR PLATE | 24 | F-1889 | 2 | CLEVIS PIN, 1/2 X 2-5/8" |
| 5 | 642-061P | 2 | HANDLE LINK | 25 | F-1521 | 2 | 1/2" FLAT WASHER |
| 6 | 642-041P | 1 | HANDLE PIVOT BRACKET | 26 | H-2239 | 2 | RUE RING, 1/2" |
| 7 | 642-127P | 1 | TOP PEG LATCH PLATE | 27 | H-2324 | 1 | VINYL GRIP, 3/8 X 1-1/2" |
| 8 | 642-126P | 1 | TOP PEG SPACER PLATE | 28 | D-3723 | 1 | 1/4" CHROME STEEL BALL |
| 9 | H-1610 | 1 | SPRING, 1-1/2" OD. X 8" | 29 | H-2390 | 1 | SPRING, .219 OD X .024 WIRE |
| 10 | 620-227W | 1 | SPRING TIGHTENER WLDT. | 30 | F-1716 | 1 | 1/4 X 1-1/2" . G.5 |
| 11 | F-1009-03 | 11 | FLAT WASHER, 3/8" | 31 | F-1158 | 1 | NUT, 1/4" STOVER |
| 12 | F-1672 | 2 | CARRIAGE BOLT, 3/8-16 X 1-1/4" | 32 | 642-178P | 1 | LATCH |
| 13 | 642-071W | 1 | SPRING ANCHOR WELDMENT | 33 | F-1015-30 | 1 | 3/8-16 X 2 1/2" GR. 5 |
| 14 | F-1526 | 1 | 3/8-16 X 1-1/2" GR. 5 | | | | |
| 15 | F-1005-05 | 2 | NUT, 1/2-13 LOCKNUT | | | | |
| 16 | F-1646 | 1 | 3/8-16 X 5" FULL THREAD | | | | |
| 17 | F-1011-03 | 3 | HEX NUT, 3/8-16 UNC-2B | | | | |
| 18 | F-1307 | 3 | 3/8-16 X 1-1/4" GR. 5 | | | | |
| 19 | F-1073 | 3 | 3/8-16 X 2" GR. 5 | | | | |

COUNTRY CLIPPER "ZETON" MOWER REPAIR PARTS AND MANUAL

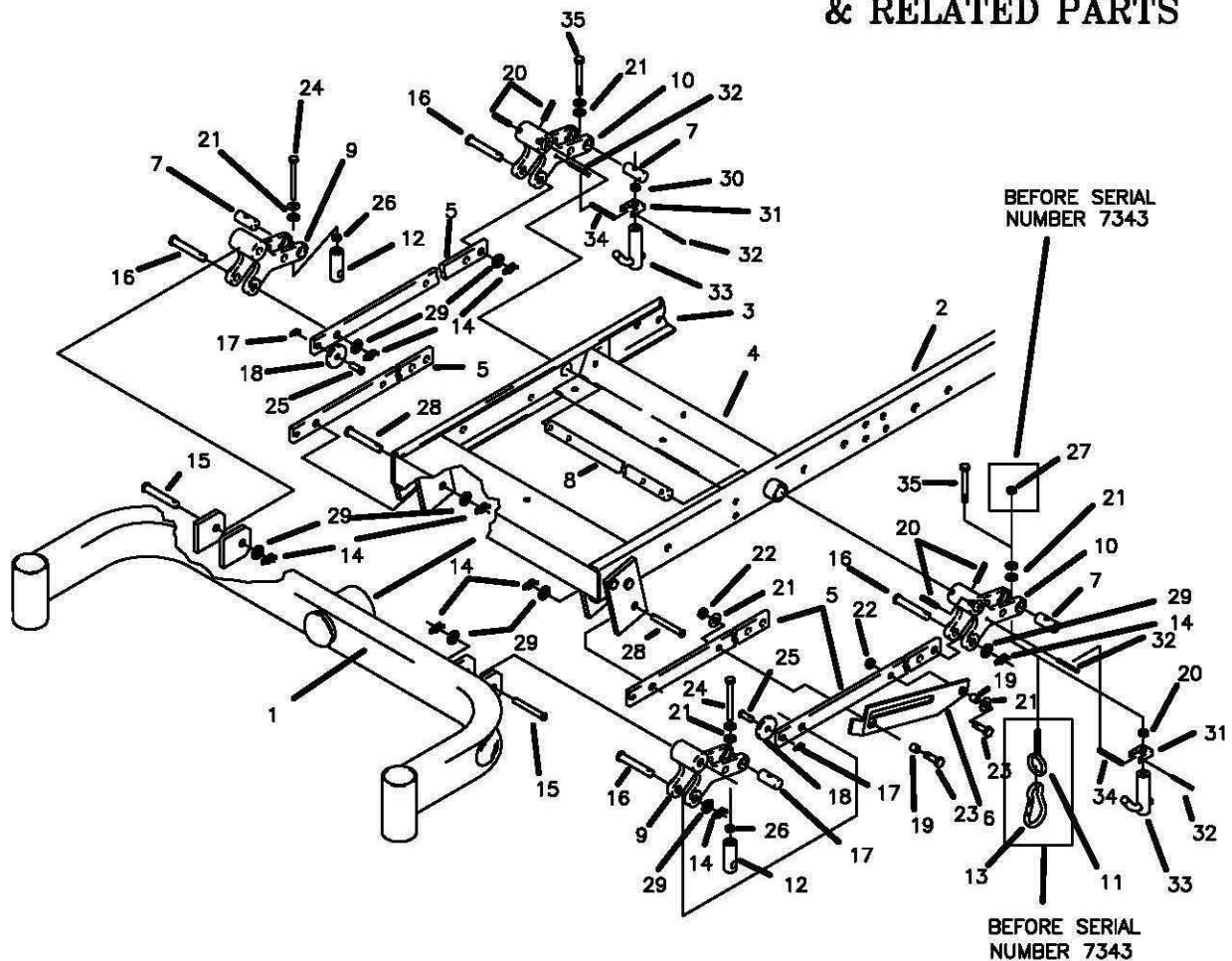
LIFT ASSEMBLY
& RELATED PARTS

| REF NO. | PART NO. | QTY. | DESCRIPTION | REF NO. | PART NO. | QTY. | DESCRIPTION |
|---------|-----------|------|-----------------------------|---------|-----------|------|----------------------------|
| 1 | 642-021W | 1 | FRONT AXLE WELDMENT | 21 | F-1009-02 | 10 | FLAT WASHER, 5/16" |
| 2 | 642-040W | 1 | FRAME WELDMENT, LH | 22 | F-1573 | 2 | LOCK NUT 3/8-24 |
| 3 | 642-039W | 1 | FRAME WELDMENT, RH | 23 | F-1572 | 2 | 3/8-24 X 1-1/2 HH GR. 5 |
| 4 | 642-019W | 1 | FRONT PIVOT CHANNEL | 24 | F-1537 | 2 | 3/8-16 X 3" HH GR. 5 |
| 5 | 642-059W | 4 | LINK BAR | 25 | F-1691 | 2 | CLEVIS PIN, 3/8 X 1" |
| 6 | 642-100P | 1 | DECK LATCH (FLIP UP) | 26 | F-1486 | 2 | 3/8-16 JAM NUT |
| 7 | 642-067P | 4 | TOP HANGER PIN | 27 | F-1239 | 2 | 3/8-16 NYLOC NUT |
| 8 | 620-061P | 1 | LIFT BAR | 28 | F-1896 | 2 | CLEVIS PIN, 1/2 X 1-3/4" |
| 9 | 642-081P | 2 | LIFT SLEEVE, FRONT | 29 | F-1521 | 8 | WASHER, 1/2 NARROW |
| 10 | 642-084P | 2 | LIFT SLEEVE, REAR | 30 | F-1486 | 2 | JAM NUT, 3/8-16 |
| 11 | 642-010P | 2 | EYE BOLT WELDMENT | 31 | 642-151P | 2 | SPRING ANCHOR |
| 12 | 642-066P | 2 | ADJUSTABLE HANGER ROD | 32 | F-1456 | 4 | ROLL PIN, 3/16 X 2" |
| 13 | H-2238 | 2 | SPRING SNAP, LOAD RATED | 33 | 642-153W | 2 | HANGER END WELDMENT |
| 14 | H-2239 | 8 | RUE RING, 1/2" | 34 | H-2104 | 2 | EXT. SPRING, 2-7/32 X .312 |
| 15 | F-1890 | 2 | CLEVIS PIN, 1/2 X 3-1/2" | 35 | F-1066 | 2 | CAPSCREW, 3/8-16 X 4" |
| 16 | F-1898 | 4 | CLEVIS PIN, 1/2 X 2-3/4" | | | | |
| 17 | F-1492 | 2 | RUE RING, 5/16-3/8 PIN | | | | |
| 18 | 642-105P | 2 | ROLLER | | | | |
| 19 | 642-069P | 2 | SPACER, TOP PEG | | | | |
| 20 | F-1036-37 | 4 | ROLL PIN, 5/16 DIA. X 1.750 | | | | |

COUNTRY CLIPPER "ZETON" MOWER REPAIR PARTS MANUAL

LIFT ASSEMBLY & RELATED PARTS

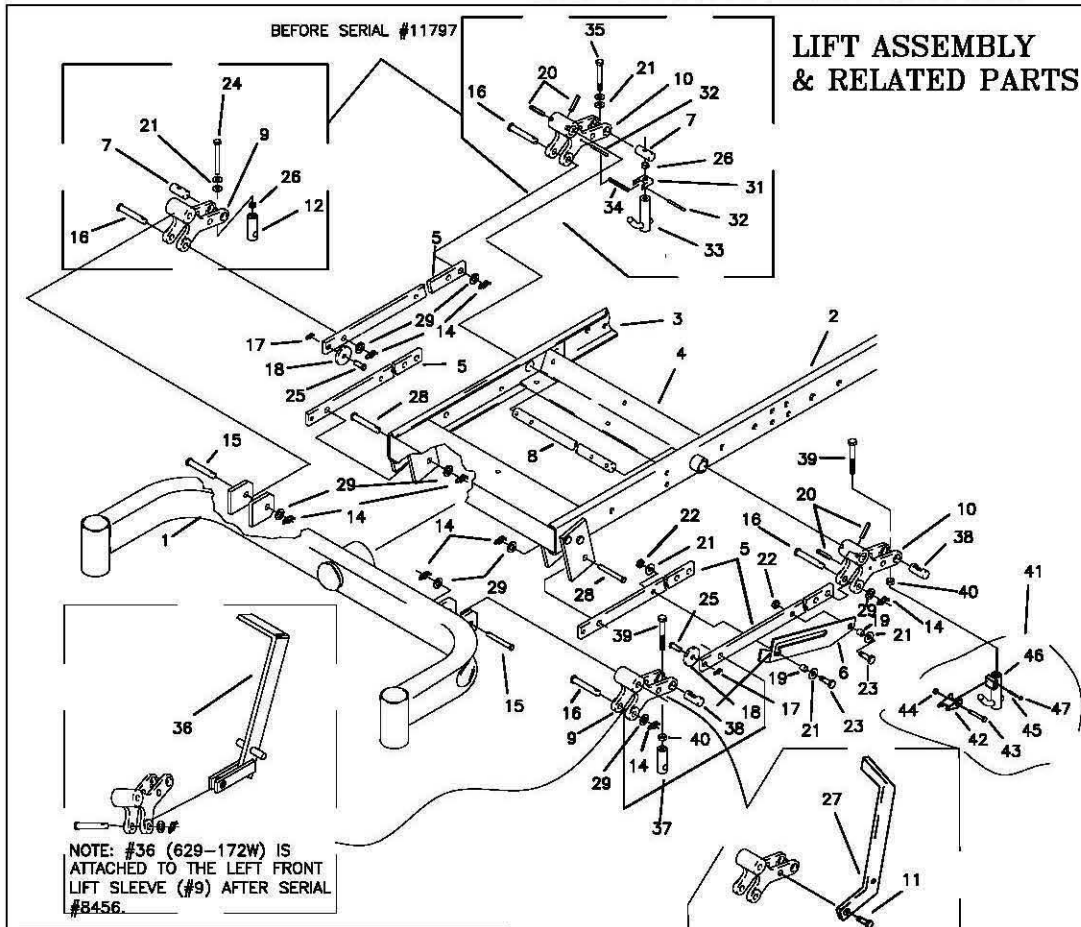

| REF NO. | PART NO. | QTY. | DESCRIPTION |
|---------|-----------|------|-----------------------------|
| 1 | 642-021W | 1 | FRONT AXLE WELDMENT |
| 2 | 642-040W | 1 | FRAME WELDMENT, LH |
| 3 | 642-039W | 1 | FRAME WELDMENT, RH |
| 4 | 642-019W | 1 | FRONT PIVOT CHANNEL |
| 5 | 642-059P | 4 | LINK BAR |
| 6 | 642-100P | 1 | DECK LATCH (FLIP UP) |
| 7 | 642-067P | 4 | TOP HANGER PIN |
| 8 | 620-051P | 1 | LIFT BAR |
| 9 | 642-081P | 2 | LIFT SLEEVE, FRONT |
| 10 | 642-082P | 2 | LIFT SLEEVE, REAR |
| 11 | F-1879 | 1 | 5/16-18 X 1 1/4", GR.5 |
| 12 | 642-066P | 2 | ADJUSTABLE HANGER ROD |
| 14 | H-2239 | 8 | RUE RING, 1/2" |
| 15 | F-1890 | 2 | CLEVIS PIN, 1/2 X 3-1/2" |
| 16 | F-1898 | 4 | CLEVIS PIN, 1/2 X 2-3/4" |
| 17 | F-1492 | 2 | RUE RING, 5/16-3/8 PIN |
| 18 | 642-105P | 2 | ROLLER |
| 19 | 642-069P | 2 | SPACER, TOP PEG |
| 20 | F-1036-37 | 4 | ROLL PIN, 5/16 DIA. X 1.750 |
| 21 | F-1009-02 | 10 | FLAT WASHER, 5/16" |
| 22 | F-1573 | 2 | LOCK NUT 3/8-24 |
| 23 | F-1572 | 2 | 3/8-24 X 1-1/2 HH GR. 5 |
| 24 | F-1816 | 2 | 3/8-16 X 3-1/4" HH GR. 5 |
| 25 | F-1691 | 2 | CLEVIS PIN, 3/8 X 1" |

| REF NO. | PART NO. | QTY. | DESCRIPTION |
|---------|----------|------|-----------------------------|
| 26 | F-1486 | 4 | 3/8-16 JAM NUT |
| 27 | 659-056P | 1 | DECK LIFT PEDAL |
| 28 | F-1896 | 2 | CLEVIS PIN, 1/2 X 1-3/4" |
| 29 | F-1521 | 8 | WASHER, 1/2 NARROW |
| 31 | 642-151P | 2 | SPRING ANCHOR |
| 32 | F-1456 | 4 | ROLL PIN, 3/16 X 2" |
| 33 | 642-153W | 2 | HANGER END WELDMENT |
| 34 | H-2104 | 2 | EXT. SPRING, 2-7/32 X .312 |
| 35 | F-1066 | 2 | CAPSCREW, 3/8-16 X 4" |
| 36 | 629-172W | 1 | FOOT ASSIST, DECK LIFT |
| 37 | 642-175P | 2 | ADJUSTABLE HANGER END |
| 38 | 642-177P | 4 | HANGER PIN |
| 39 | F-1936 | 4 | 1/2-13 X 3-1/2, 2" THREAD |
| 40 | F-1489 | 4 | NUT, 1/2" JAM |
| 41 | 642-183A | 2 | REAR DECK HANGER ASSEMBLY |
| 42 | 642-178P | 1 | LATCH |
| 43 | F-1716 | 1 | 1/4 X 1-1/2", G.5 |
| 44 | F-1158 | 1 | NUT, 1/4" STOVER |
| 45 | H-2390 | 1 | SPRING, .219 OD X .024 WIRE |
| 46 | 642-176W | 1 | REAR DECK HANGER WLDT |
| 47 | D-3723 | 1 | 1/4" CHROME STEEL BALL |

COUNTRY CLIPPER "ZETON" MOWER REPAIR PARTS MANUAL

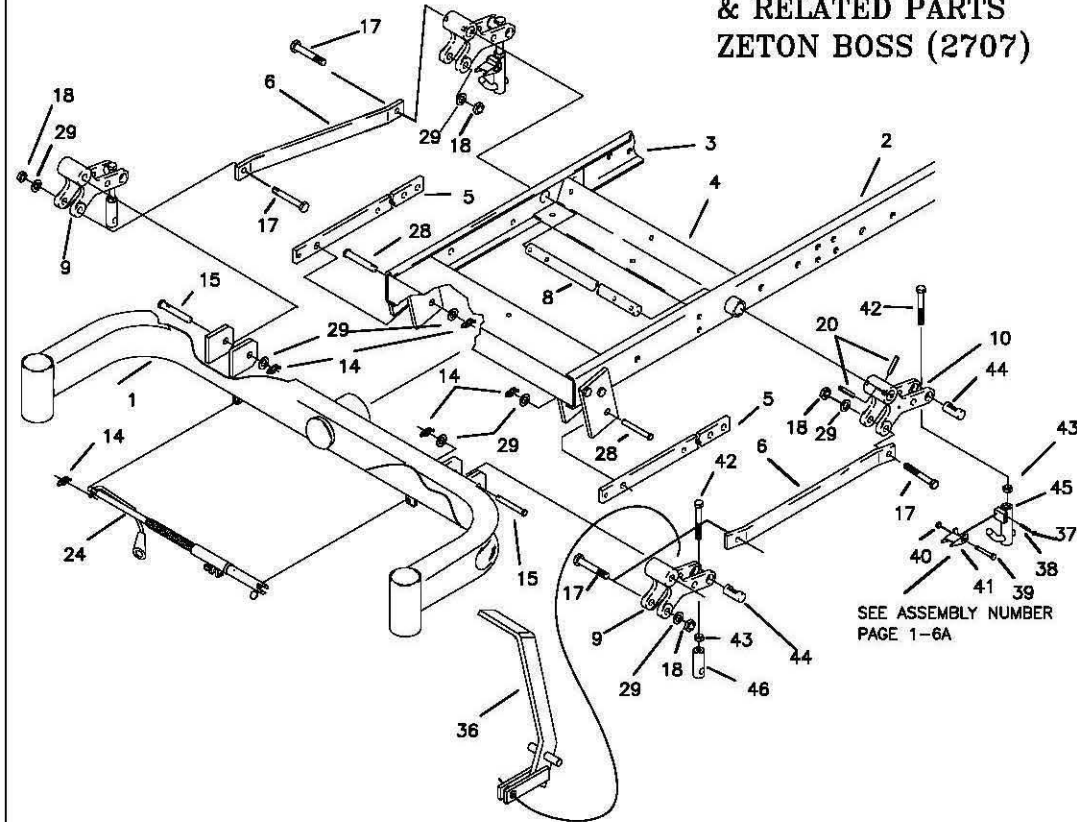
LIFT ASSEMBLY
& RELATED PARTS
ZETON BOSS (2707)

| REF NO. | PART NO. | QTY. | DESCRIPTION | REF NO. | PART NO. | QTY. | DESCRIPTION |
|---------|-----------|------|-----------------------------|---------|----------|------|---|
| 1 | 642-180W | 1 | WIDE FRONT AXLE WELDMENT | 24 | 629-260A | 1 | DECK FLIP/TIRE JACK ASSY. (SEE BREAK-DOWN PAGE 3-12) |
| 2 | 642-040W | 1 | FRAME WELDMENT, LH | 27 | - | - | - |
| 3 | 642-039W | 1 | FRAME WELDMENT, RH | 28 | F-1896 | 2 | CLEVIS PIN, 1/2 X 1-3/4" |
| 4 | 642-019W | 1 | FRONT PIVOT CHANNEL | 29 | F-1521 | 8 | WASHER, 1/2 NARROW |
| 5 | 642-059P | 2 | LINK BAR | 30 | - | - | - |
| 6 | 647-071P | 2 | OFFSET LINK BAR | 31 | - | - | - |
| 7 | - | - | - | 32 | - | - | - |
| 8 | 620-051P | 1 | LIFT BAR | 33 | - | - | - |
| 9 | 642-081P | 2 | LIFT SLEEVE, FRONT | 34 | - | - | - |
| 10 | 642-082P | 2 | LIFT SLEEVE, REAR | 35 | - | - | - |
| 11 | - | - | - | 36 | 629-249W | 1 | OFFSET DECK LIFT PEDAL |
| 12 | - | - | - | 37 | D-3723 | 2 | 1/4" CHROME STEEL BALL |
| 13 | - | - | - | 38 | H-2390 | 2 | SPRING, .219 OD X .024 WIRE |
| 14 | H-2239 | 4 | RUE RING, 1/2" | 39 | F-1716 | 2 | 1/4 X 1-1/2", G.5 |
| 15 | F-1890 | 2 | CLEVIS PIN, 1/2 X 3-1/2" | 40 | F-1158 | 2 | NUT, 1/4" STOVER |
| 16 | - | - | - | 41 | 642-178P | 2 | LATCH |
| 17 | F-1439 | 2 | 1/2-13 X 3", GR.5 | 42 | F-1936 | 4 | 1/2-13 X 3-1/2, 2" THREAD |
| 18 | F-1005-05 | 2 | NUT, 1/2" STOVER | 43 | F-1489 | 4 | NUT, 1/2" JAM |
| 19 | - | - | - | 44 | 642-177P | 2 | HANGER PIN |
| 20 | F-1036-37 | 4 | ROLL PIN, 5/16 DIA. X 1.750 | 45 | 642-176W | 2 | REAR DECK HANGER WLDT |
| 21 | - | - | - | 46 | 642-175P | 2 | ADJUSTABLE HANGER END |
| 22 | F-1573 | 2 | LOCK NUT 3/8-24 | | | | |
| 23 | F-1572 | 2 | 3/8-24 X 1-1/2 HH GR. 5 | | | | |

COUNTRY CLIPPER "ZETON" MOWER REPAIR PARTS MANUAL

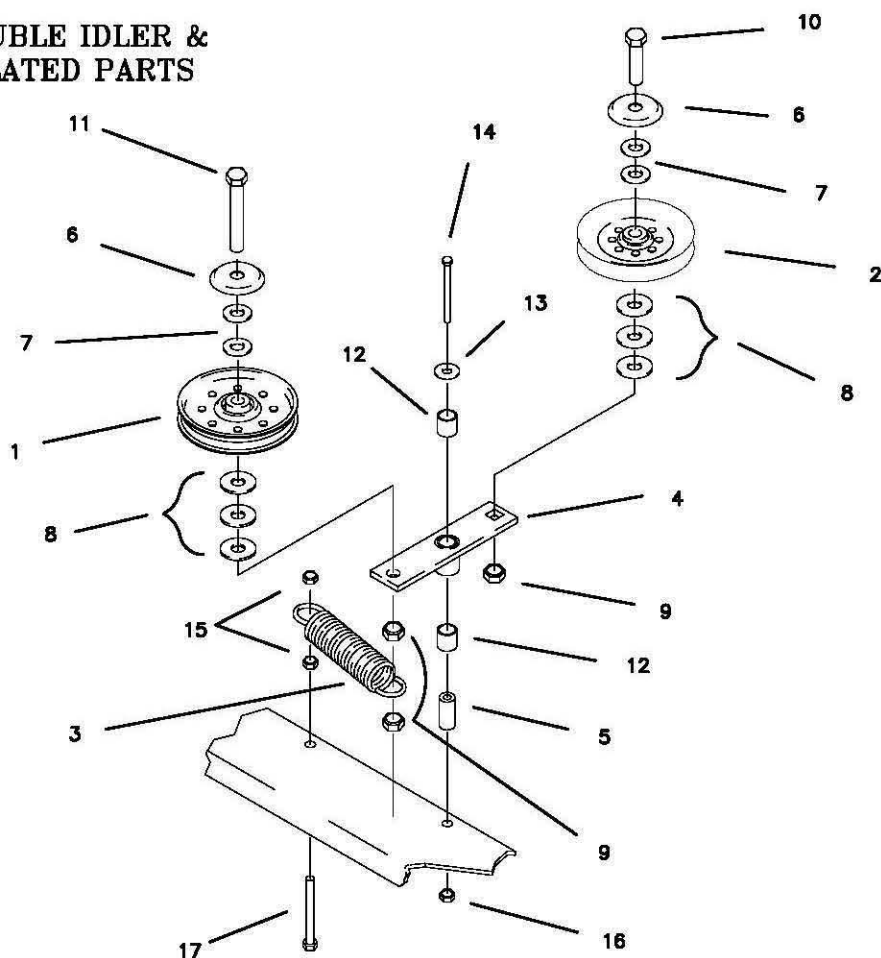
DOUBLE IDLER &
RELATED PARTS

| REF NO. | PART NO. | QTY. | DESCRIPTION |
|---------|-----------|------|------------------------------|
| 1 | D-3617 | 1 | FLAT IDLER PULLEY |
| 2 | D-3337 | 1 | V-IDLER PULLEY |
| 3 | H-2092 | 1 | SPRING |
| 4 | 636-086W | 1 | IDLER ARM |
| 5 | 621-103P | 1 | PIN |
| 6 | 620-201P | 2 | BEARING CAP |
| 7 | F-1521 | 4 | 1/2" FLAT WASHER, (NARROW) |
| 8 | F-1009-05 | 6 | 1/2" FLAT WASHER, (STANDARD) |
| 9 | F-1005-05 | 3 | 1/2" LOCK NUT |
| 10 | F-1293 | 1 | 1/2-13 X 2" GR. 5 |
| 11 | F-1668 | 1 | 1/2-13 X 2-3/4" GR. 5 |
| 12 | D-3573 | 2 | BUSHING DX 5/8 X 3/4 |
| 13 | F-1009-02 | 1 | 5/16 FLAT WASHER |
| 14 | F-1820 | 1 | 5/16-18 X 2-1/4" GR. 5 |
| 15 | F-1573 | 2 | 3/8-24 LOCK NUT |
| 16 | F-1125 | 1 | 5/16 LOCK NUT |
| 17 | F-1574 | 1 | 3/8-24 X 1 1/4" GR. 5 |
| 18 | - | - | - |

COUNTRY CLIPPER "ZETON" MOWER REPAIR PARTS MANUAL

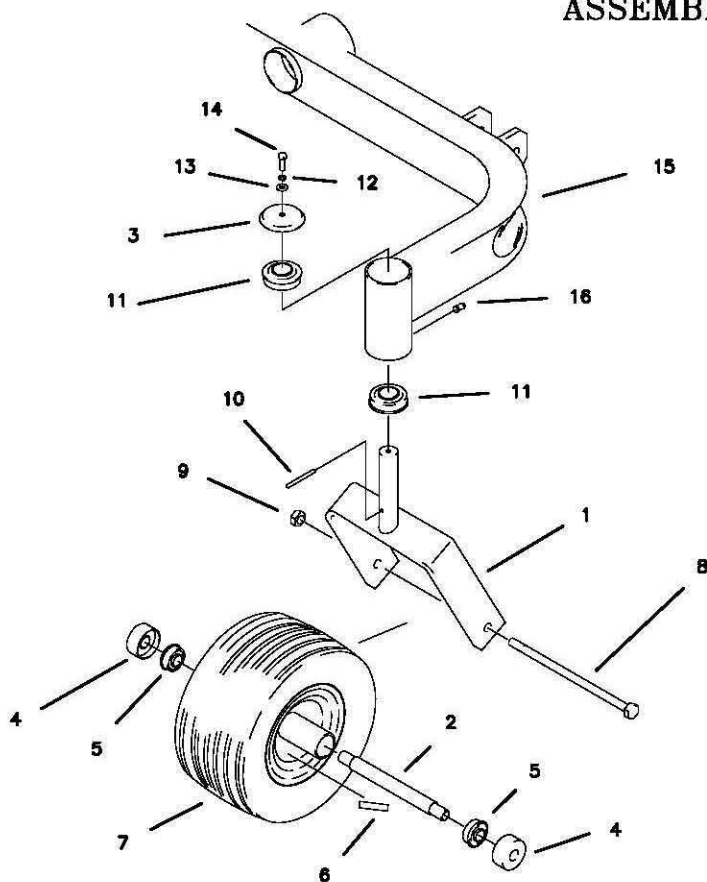
CASTER WHEEL
ASSEMBLY

| REF NO. | PART NO. | QTY. | DESCRIPTION |
|---------|-----------|------|----------------------------|
| 1 | 647-003W | 1 | CASTER WELDMENT |
| 2 | 647-038P | 2 | BEARING SPACER |
| 3 | 609-099P | 2 | BEARING CAP |
| 4 | 611-135P | 4 | BEARING SHIELD |
| 5 | D-3432 | 4 | BEARING, 5/8 ID X 1-3/8 OD |
| 6 | P-11384 | 2 | DECAL, 12, PSI |
| 7 | D-3670 | 2 | TIRE, 13 X 650-6 (RIBBED) |
| - | - | - | - |
| 8 | F-1908 | 2 | 1/2-13 X 9" GR. 8 BOLT |
| 9 | F-1005-05 | 2 | 1/2-13 LOCK NUT |
| 10 | F-1456 | 2 | 3/16 ROLL PIN |
| 11 | D-2008-02 | 4 | BEARING, SPD SF-16-32 |
| 12 | F-1009-01 | 2 | 1/4" FLAT WASHER |
| 13 | F-1019-01 | 2 | 1/4" LOCK WASHER |
| 14 | F-1810 | 2 | 1/4-20 X 3/4 W/NYLON PATCH |
| 15 | ----- | 1 | SEE PAGE 1-6-A OR 1-6-B |
| 16 | H-1056 | 2 | GREASE ZERK |

COUNTRY CLIPPER "ZETON" MOWER REPAIR PARTS MANUAL

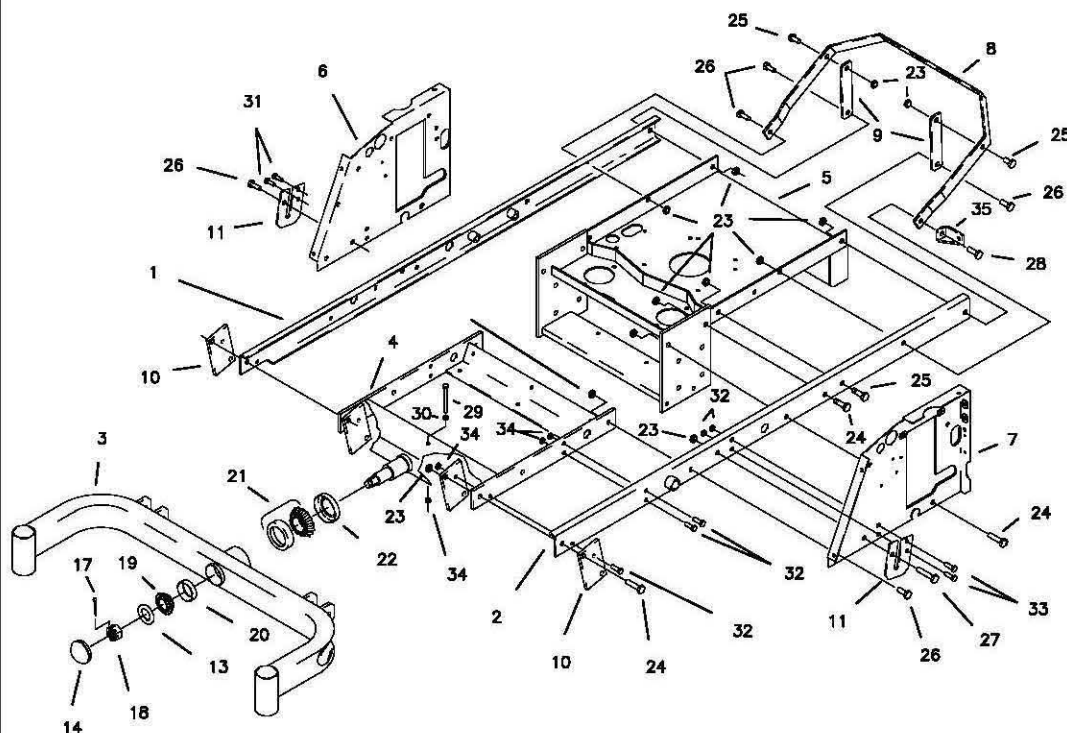

FRAME SIDES &
RELATED PARTS

| REF NO. | PART NO. | QTY. | DESCRIPTION | REF NO. | PART NO. | QTY. | DESCRIPTION |
|---------|-----------|-------|-------------------------|---------|-----------|------|------------------------|
| 1 | 642-039W | 1 | FRAME SIDE RH. | 20 | D-2014-01 | 1 | BEARING CUP, 2.328 ID. |
| 2 | 642-040W | 1 | FRAME SIDE LH. | 21 | D-3646 | 1 | TAPERED ROLLER BRG. |
| 3 | 642-021W | 1 | FRONT AXLE | 22 | D-3647 | 1 | SEAL, #19992 |
| | 642-180W | 1 | FRONT AXLE (ZETON BOSS) | 23 | F-1005-05 | 16 | 1/2" LOCK NUT |
| 4 | 642-019W | 1 | FRONT PIVOT CHANNEL | 24 | F-1293 | 6 | 1/2-13 X 2" GR. 5 |
| 5 | 647-005W | 1 | MOTOR MOUNT WLDT. | 25 | F-1759 | 4 | 1/2-13 X 1" GR.5 |
| 6 | 642-049P | 1 | SIDE PANEL RH. | 26 | F-1386 | 4 | 1/2-13 X 1-1/4" GR. 5 |
| 7 | 642-050P | 1 | SIDE PANEL LH. | 27 | F-1828 | 1 | 1/2-13 X 3-1/2" GR. 5 |
| 8 | 642-093P | 1 | ENGINE GUARD | 28 | F-1526 | 1 | 1/2-13 X 1-1/2" GR. 5 |
| 9 | 642-015P | 2 | ENGINE GUARD MNT. LEG | 29 | F-1073 | 1 | 3/8-16 X 2" GR. 5 |
| 10 | 642-063P | 4 | DRAG BAR TAB | 30 | F-1011-03 | 1 | 3/8-16 NUT, UNC-2B |
| 11 | 642-042P | 2 | BRAKE ROD MOUNT | 31 | F-1558 | 4 | 3/8-16 X 7/8" GR. 5 |
| 12 | ----- | ----- | ----- | 32 | F-1558 | 2 | 3/8-16 X 7/8" GR. 5 |
| 13 | 606-303P | 1 | 1" WASHER | 33 | F-1307 | 2 | 3/8-16 X 1-1/4" GR. 5 |
| 14 | 620-206P | 1 | GREASE CAP | 34 | F-1239 | 11 | 3/8-16 LOCK NUT |
| 15 | ----- | ----- | ----- | 35 | 642-071W | 1 | SPRING ANCHOR |
| 16 | ----- | ----- | ----- | | | | |
| 17 | F-1728 | 1 | 3/16 X 2" COTTER PIN | | | | |
| 18 | F-1724 | 1 | 1"-14 CASTLE NUT | | | | |
| 19 | D-2013-01 | 1 | BEARING CONE, 1.25 BORE | | | | |

COUNTRY CLIPPER "ZETON" MOWER REPAIR PARTS MANUAL

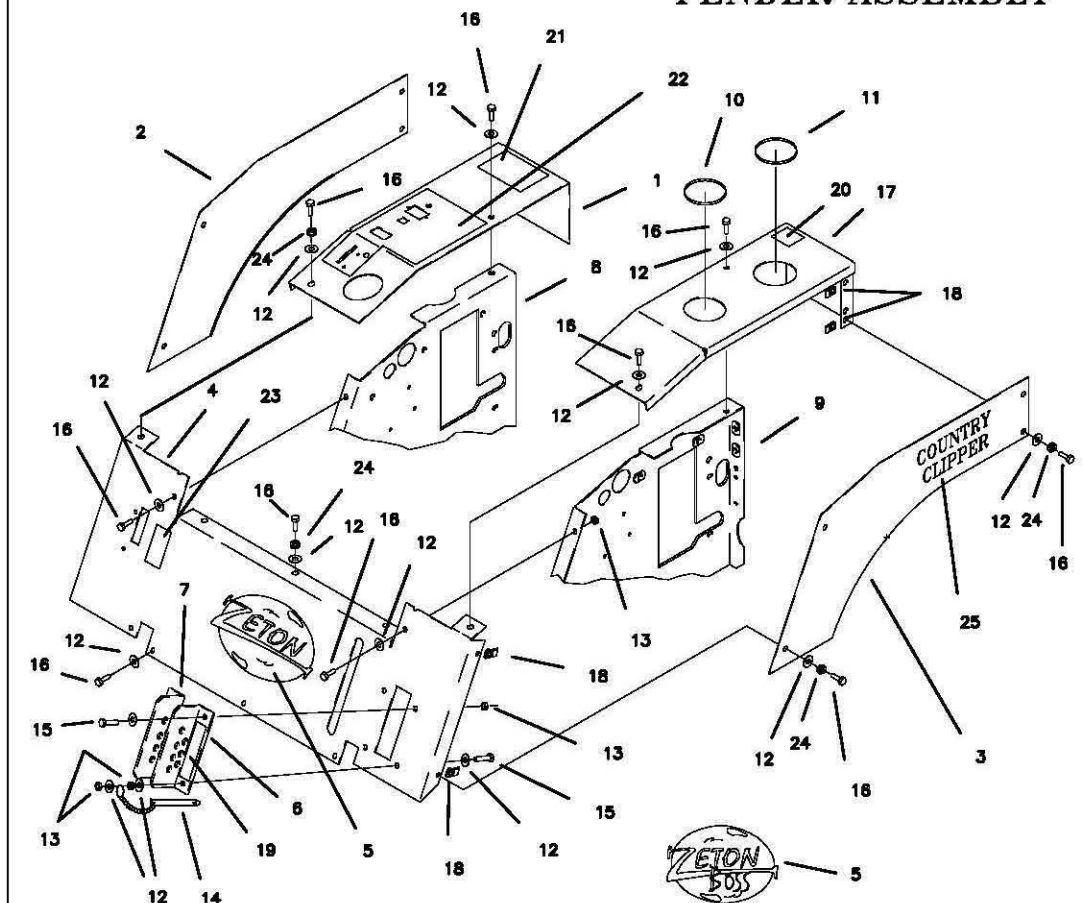
FENDER ASSEMBLY



| REF NO. | PART NO. | QTY. | DESCRIPTION | REF NO. | PART NO. | QTY. | DESCRIPTION |
|---------|-----------|------|---|---------|-----------|------|-----------------------------|
| 1 | 642-133A | 1 | FENDER CAP RH W/DECAL | 16 | F-1015-15 | 21 | 5/16-18 X 1" GR.5 |
| - | 642-140A | - | FDR. CAP RH. 2 LEV. W/DECAL | 17 | 642-170A | 1 | FENDER CAP LH. W/DECAL |
| - | 647-068A | - | FDR. CAP RH W/EFI DECAL | - | 642-171A | - | FDR. CAP LH. 2 LEV. W/DECAL |
| 2 | 642-134A | 1 | FENDER SKIRT RH W/DECAL | 18 | F-1860 | 8 | 5/16 U-NUT |
| 3 | 642-135A | 1 | FENDER SKIRT LH W/DECAL | 19 | P-11407 | 1 | DECAL, "CUT HEIGHT" |
| 4 | 647-042A | 1 | FRONT PANEL ASS'Y. W/DECAL P-11524 | 20 | P-10939 | 1 | DECAL, "CAUTION" |
| - | 647-075A | 1 | FRONT PANEL ASS'Y. W/DECAL P-11638 | 21 | P-11370 | 1 | DECAL, "WARNING" |
| 5 | P-11524 | 1 | DECAL,  | 22 | P-11369 | 1 | DECAL, RH. FENDER CAP |
| - | P-11638 | 1 | DECAL,  | 23 | P-11382 | 1 | DECAL, PARK BRAKE |
| 6 | 642-131P | 1 | LATCH PLATE LH. | 24 | F-1019-02 | 15 | 5/16 LOCK WASHER |
| 7 | 642-137A | 1 | LATCH PLATE, RH, W/DECAL | 25 | P-11112 | 2 | DECAL, "COUNTRY CLIPPER" |
| 8 | 642-049P | 1 | SIDE PANEL RH. | 26 | | | |
| 9 | 642-050P | 1 | SIDE PANEL LH. | 27 | | | |
| 10 | 644-029P | 1 | TRIM, FUEL TANK | 28 | | | |
| 11 | 644-030P | 1 | TRIM, OIL TANK | 29 | | | |
| 12 | F-1009-02 | 27 | 5/16 FLAT WASHER | 30 | | | |
| 13 | F-1125 | 16 | 5/16-18 LOCK NUT | 31 | | | |
| 14 | F-1807 | 1 | 1/2" X 2.4 CLEVIS PIN W/SASH | 32 | | | |
| 15 | F-1879 | 3 | 5/16-18 X 1-1/4" GR. 5 | 33 | | | |

COUNTRY CLIPPER "ZETON" MOWER REPAIR PARTS MANUAL

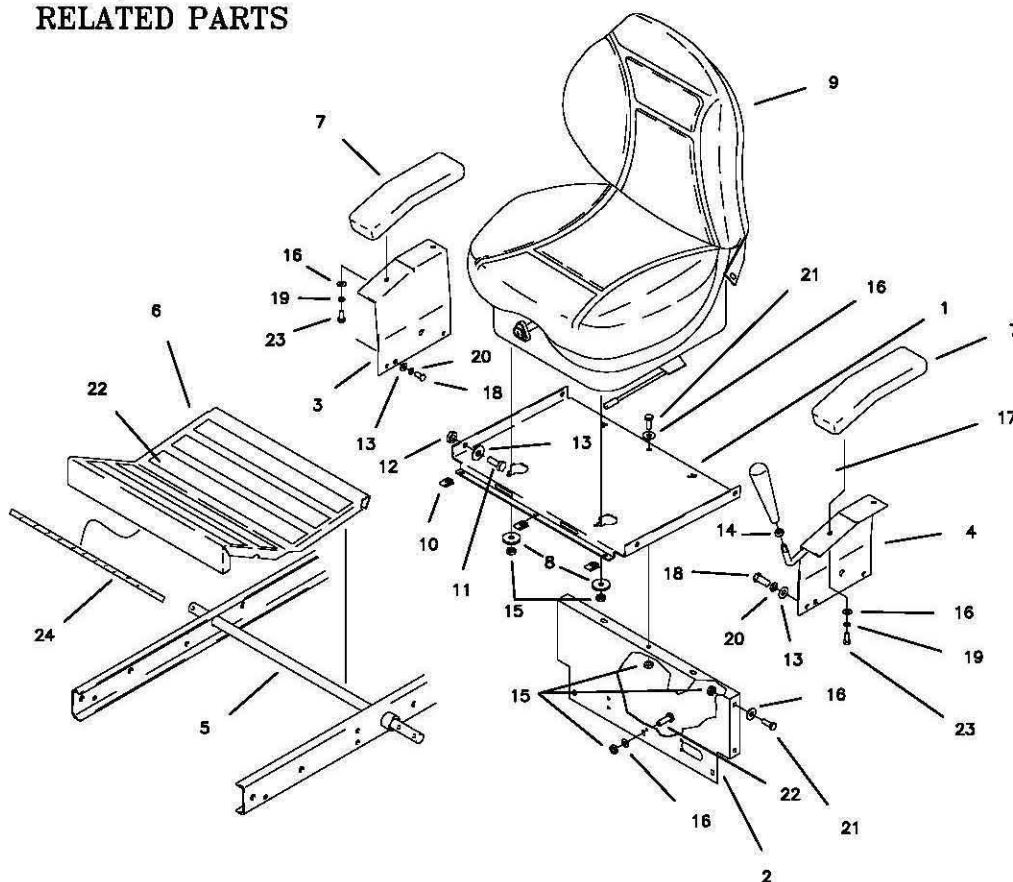
SEAT, FOOTDECK &
RELATED PARTS

| REF NO. | PART NO. | QTY. | DESCRIPTION | REF NO. | PART NO. | QTY. | DESCRIPTION |
|---------|-----------|------|-------------------------|---------|-----------|------|--------------------------|
| 1 | 642-030P | 1 | SEAT BRACKET | - | H-2130 | 1 | ROUND GRIP BALL |
| 2 | 642-086P | 1 | REAR BRACE | 18 | F-1755 | 4 | 3/8-16 X 1/2" GR. 5 |
| 3 | 647-047P | 1 | ARM REST RH. (JOYSTICK) | 19 | F-1019-02 | 4 | 5/16 LOCK WASHER |
| - | 636-163P | 1 | ARM REST, (TWIN STICK) | 20 | F-1019-03 | 4 | 3/8 LOCK WASHER |
| 4 | 647-049W | 1 | ARM REST LH. (JOYSTICK) | 21 | F-1546 | 6 | 5/16-18 X 3/4" GR. 5 |
| - | 636-163P | 1 | ARM REST, (TWIN STICK) | 22 | H-1931 | 5 | SAFETY TREAD |
| 5 | 620-051P | 1 | LIFT BAR | 23 | F-1015-15 | 4 | 5/16-18 X 1" GR. 5 |
| 6 | 642-139A | 1 | FOOT DECK ASSEMBLY | 24 | 850-016P | 1 | TRIM, U-CHANNEL, 18 3/4" |
| 7 | 621-143A | 2 | ARM REST PAD | | | | |
| 8 | 609-034P | 2 | FLAT WASHER | | | | |
| 9 | H-2274 | 1 | DELUXE SEAT | | | | |
| - | H-2229 | - | STANDARD SEAT | | | | |
| 10 | F-1860 | 3 | U-NUT 5/16-18 | | | | |
| 11 | F-1394 | 4 | 3/8-13 X 1" GR. 5 | | | | |
| 12 | F-1239 | 4 | 3/8-13 LOCK NUT | | | | |
| 13 | F-1009-03 | 4 | 3/8 FLAT WASHER | | | | |
| 14 | F-1011-03 | 1 | 3/8-16 PLAIN NUT | | | | |
| 15 | F-1005-02 | 14 | 5/16-18 LOCK NUT | | | | |
| 16 | F-1009-02 | 10 | 5/16 FLAT WASHER | | | | |
| 17 | H-2317 | 1 | TAPERED GRIP BALL | | | | |

COUNTRY CLIPPER "ZETON" MOWER REPAIR PARTS MANUAL

DECK FLIP/TIRE JACK ASSEMBLY (629-260A)

(STANDARD ON ZETON BOSS)

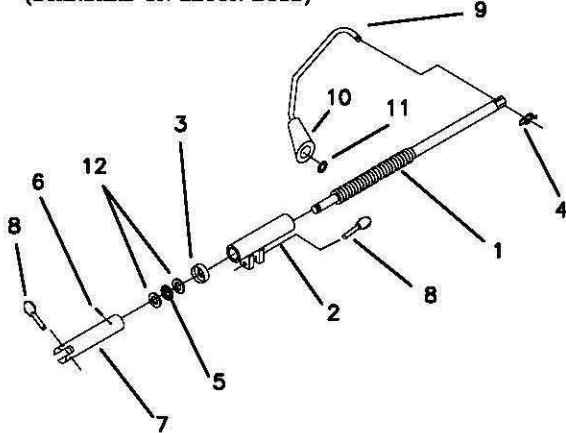

NOTE:
 (1) LIGHTLY GREASE BEARING, THRUST WASHERS, AND BORE ON LOWER JACK CONNECTOR PRIOR TO ASSEMBLY.
 (2) ROLL PIN, F-1458, MUST FIT INTO GROOVE ON JACK SCREW WELDMENT

| REF NO. | PART NO. | QTY. | DESCRIPTION |
|---------|-----------------|----------|----------------------------|
| | 629-260A | 1 | DECK FLIP/TIRE JACK |
| 1 | 629-217W | 1 | JACK SCREW WELDMENT |
| 2 | 629-212W | 1 | JACK LIFT COLLAR WLDT. |
| 3 | 629-210P | 1 | BEARING CAP |
| 4 | H-2239 | 1 | RUE RING |
| 5 | D-3675 | 1 | THRUST BEARING |
| 6 | F-1458 | 1 | ROLL PIN, 1/8" X 3/4 |
| 7 | 629-208P | 1 | LOWER JACK CONNECTOR |
| 8 | F-1914 | 2 | QUICK PIN, 1/4" X 1 3/8 |
| 9 | 629-216P | 1 | CRANK HANDLE |
| 10 | H-2343 | 1 | KNOB |
| 11 | F-1913 | 1 | PUSH RETAINER |
| 12 | D-3676 | 2 | THRUST WASHER |

FUEL TANK ASSEMBLY

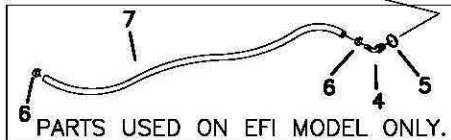
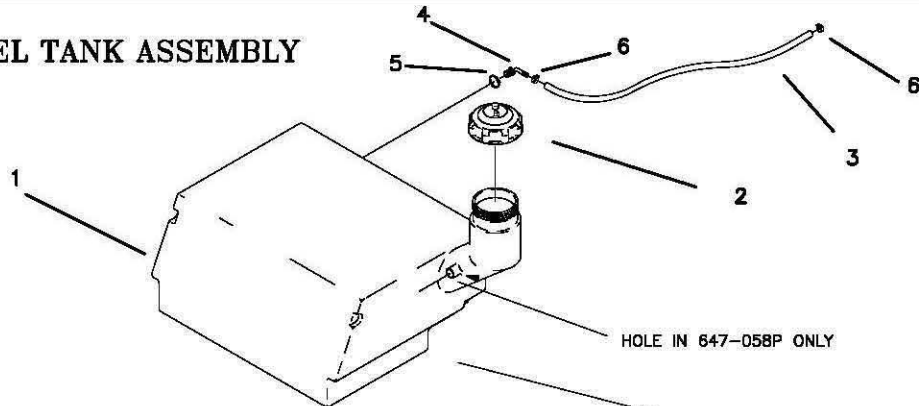

| REF NO. | PART NO. | QTY. | DESCRIPTION |
|---------|----------|------|---|
| 1 | H-2234 | 1 | 11 GALLON TANK |
| - | 647-058P | - | 11 GALLON TANK FOR E.F.I. MODEL |
| 2 | H-2232 | 1 | GAS CAP |
| 3 | 644-034P | 1 | 29-1/2" FUEL LINE |
| - | - | - | - |
| 4 | H-1646 | 1 | HOSE BARB, 90 DEG. |
| - | H-2373 | 1 | HOSE BARB, 5/16 X 1/4NPT X 90° ELBOW (E.F.I.) MODEL |
| 5 | H-1952 | 1 | HOSE CLAMP |
| - | - | - | HOSE CLAMP (E.F.I.) MODEL |
| 6 | H-1687 | 2 | HOSE CLAMP, 1/2" |
| - | - | - | HOSE CLAMP, 1/2" (E.F.I.) MODEL |
| 7 | 647-063P | 1 | 46" LONG 1/4" ID FUEL LINE |

COUNTRY CLIPPER "ZETON" MOWER REPAIR PARTS MANUAL

JOYSTICK STEERING CONTROL AND RELATED PARTS

NOTE: ITEM'S #2 AND #3 MUST BE REPLACED AT THE SAME TIME FOR MAXIMUM PERFORMANCE.

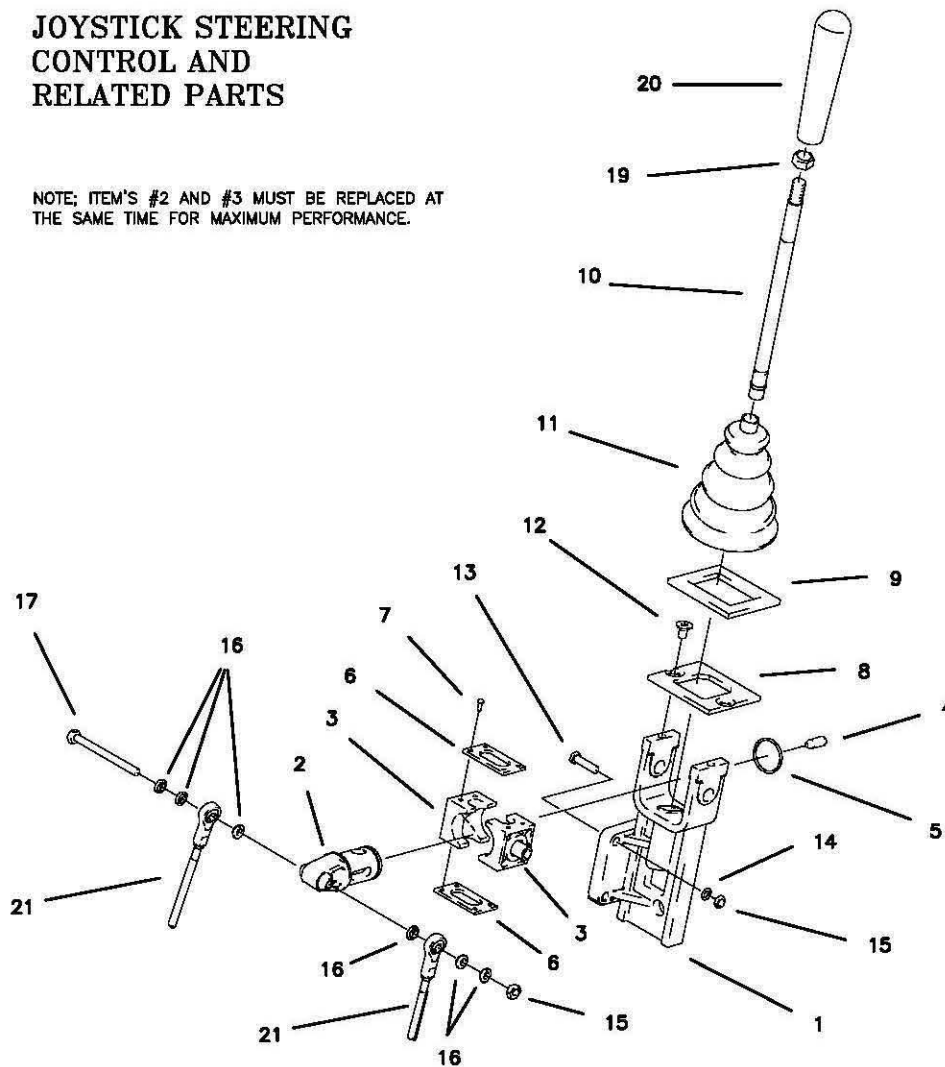

| REF NO. | PART NO. | QTY. | DESCRIPTION | REF NO. | PART NO. | QTY. | DESCRIPTION |
|---------|----------|------|-------------------------|---------|-----------|------|--------------------------|
| - | 636-141A | 1 | JOYSTICK ASSEMBLY | 11 | H-1991 | 1 | BOOT, BELLOWS |
| 1 | 621-124P | 1 | JOYSTICK YOKE | 12 | F-1714 | 2 | 1/4-20 X 1/2" FHCS GR. 5 |
| 2 | H-1992 | 1 | PIVOT SHAFT | 13 | F-1015-05 | 3 | 1/4-20 X 1" HHCS GR. 5 |
| 3 | 619-307P | 2 | PIVOT BLOCK | 14 | F-1019-01 | 3 | 1/4" LOCK WASHER |
| 4 | F-1120 | 1 | BALL PLUNGER | 15 | F-1158 | 4 | 1/4-20 LOCK NUT |
| 5 | H-1987 | 1 | SNAP RING, SPIRLOCK | 16 | H-1989 | 6 | BUSHING, BALL JOINT |
| 6 | 619-306P | 2 | PIVOT BLOCK PLATE | 17 | F-1765 | 1 | 1/4-20 X 3" GR. 5 |
| 7 | F-1624 | 8 | #6-32 X 3/8" SCREW SLOT | 18 | - | - | - |
| 8 | 636-140P | 1 | JOYSTICK TOP PLATE | 19 | F-1011-03 | 1 | 3/8-16 NUT, JAM |
| 9 | H-1947 | 1 | GASKET, FOAM | 20 | H-2317 | 1 | GRIP, HANDLE |
| 10 | 621-140A | 1 | JOYSTICK SHAFT ASSEMBLY | - | - | - | - |
| | | | | 21 | H-2125 | 2 | LINKAGE ASSEMBLY |

COUNTRY CLIPPER "ZETON" MOWER REPAIR PARTS MANUAL

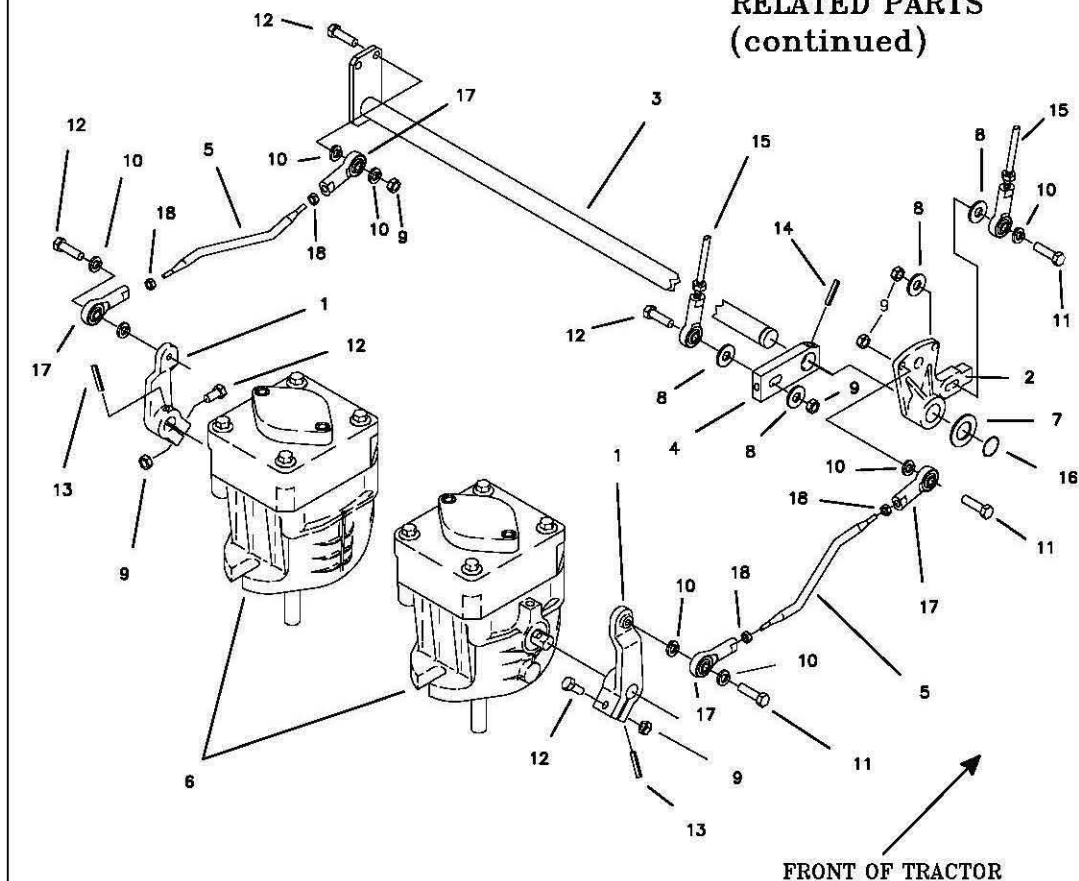
JOYSTICK STEERING
CONTROL AND
RELATED PARTS
(continued)

| REF NO. | PART NO. | QTY. | DESCRIPTION |
|---------|-----------|------|-----------------------|
| 1 | 625-026P | 2 | SHIFT ARM |
| 2 | 638-027A | 1 | LINKAGE DISK ASSEMBLY |
| 3 | 636-078W | 1 | SHIFT ROD |
| 4 | 625-030P | 1 | SWIVEL ARM |
| 5 | 647-024P | 2 | LOWER LINKAGE ROD |
| 6 | - | - | SEE PAGE 3-20 |
| 7 | 610-103P | 1 | THRUST WASHER |
| 8 | F-1009-01 | 4 | 1/4" FLAT WASHER |
| 9 | F-1158 | 6 | 1/4-20 LOCK NUT |
| 10 | F-1019-01 | 8 | 1/4" LOCK WASHER |
| 11 | F-1716 | 4 | 1/4-20 X 1-1/2" GR. 5 |
| 12 | F-1015-05 | 4 | 1/4-20 X 1" GR. 5 |
| 13 | F-1725 | 2 | ROLL PIN, 5MM X 26MM |
| 14 | F-1503 | 2 | ROLL PIN, 3/16" X 1" |
| 15 | H-2125 | 2 | UPPER LINKAGE |
| 16 | F-1739 | 1 | SPIROL RING |
| 17 | H-1885 | 4 | BALL JOINT |
| 18 | F-1487 | 4 | 1/4-24 NUT |

COUNTRY CLIPPER "ZETON" MOWER REPAIR PARTS MANUAL

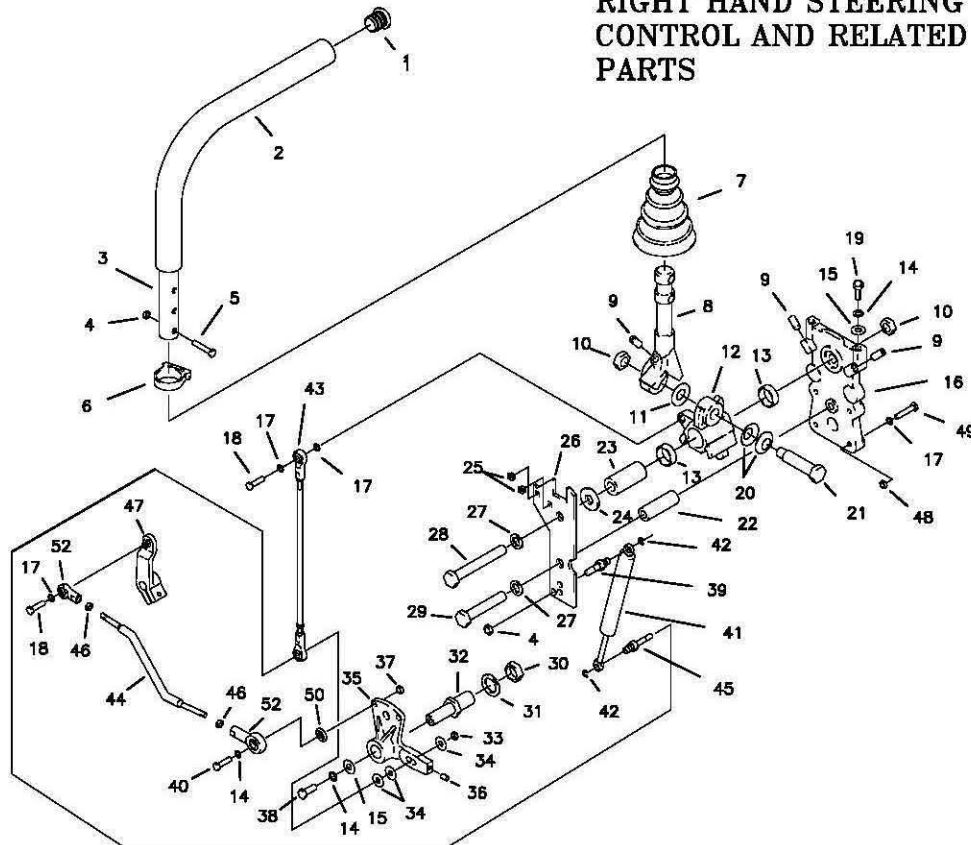
RIGHT HAND STEERING
CONTROL AND RELATED
PARTS

| REF NO. | PART NO. | QTY. | DESCRIPTION | REF NO. | PART NO. | QTY. | DESCRIPTION |
|---------|-----------|------|-----------------------------|---------|-----------|------|-----------------------------|
| 1 | H-2080 | 1 | END PLUG, 15/16" BLACK | 27 | F-1464 | 2 | 1/2" LOCK WASHER |
| 2 | H-2079 | 1 | FOAM GRIP, 17" | 28 | F-1828 | 1 | 1/2-13 X 3-1/2" HHCS GR. 5 |
| 3 | 642-004A | 1 | CONTROL LEVER ASSEMBLY | 29 | F-1439 | 1 | 1/2-13 X 3" HHCS GR. 5 |
| 4 | F-1125 | 3 | 5/16 LOCK NUT | 30 | F-1011-07 | 1 | 3/4-10 PLAIN NUT |
| 5 | F-1015-17 | 2 | 5/16-18 X 1-1/2" HHCS GR. 5 | 31 | F-1463 | 1 | 3/4" LOCK WASHER |
| 6 | H-2089 | 1 | HOSE CLAMP | 32 | 623-048P | 1 | LINKAGE PINTLE |
| 7 | H-2081 | 1 | BOOT, TAPERED 1" CUFF | 33 | F-1158 | 1 | 1/4-20 LOCK NUT |
| 8 | 625-063P | 1 | LEVER, DUALEVER | 34 | F-1009-01 | 3 | 1/4" FLAT WASHER |
| 9 | F-1842 | 3 | SETSCREW, 5/16-18 X 3/4" | 35 | 638-027A | 1 | LINKAGE DISK ASSEMBLY |
| 10 | F-1489 | 2 | 1/2-13 JAM NUT | 36 | F-1695 | 1 | SETCREW, 1/4-20 X 3/8" |
| 11 | H-2116 | 1 | WASHER, FIBER | 37 | F-1011-01 | 1 | 1/4-20 PLAIN NUT |
| 12 | 638-033P | 1 | PIVOT BLOCK, DUALEVER | 38 | F-1015-14 | 1 | 5/16-18 X 7/8" HHCS GR. 5 |
| 13 | D-3622 | 2 | BEARING | 39 | 638-028P | 1 | DAMPER BOLT, 5-16-18 X 3/4" |
| 14 | F-1019-02 | 2 | 5/16" LOCK WASHER | 40 | F-1716 | 1 | 1/4-20 X 1-1/2" HHCS GR. 5 |
| 15 | F-1009-02 | 2 | WASHER, FLAT STD. 5/16" | 41 | H-2168 | 1 | STEERING DAMPER |
| 16 | 638-034P | 1 | BASE DUALEVER | 42 | F-1610 | 2 | E-RING FOR 1/4" SHAFT |
| 17 | F-1019-01 | 11 | 1/4" LOCK WASHER | 43 | H-2125 | 1 | UPPER LINKAGE |
| 18 | F-1015-05 | 1 | 1/4-20 X 1" HHCS GR. 5 | 44 | 647-024P | 1 | LOWER LINKAGE |
| 19 | F-1546 | 1 | 5/16-18 X 3/4" HHCS GR. 5 | 45 | 638-029P | 1 | DAMPER BOLT, 1/4-20 |
| 20 | H-2115 | 2 | WASHER, SPRING | 46 | F-1487 | 2 | NUT, HEX 1/4-28 UNF |
| 21 | 625-070P | 1 | SHOULDER BOLT, 5/8" OD | 47 | 625-026P | 1 | SHIFT ARM |
| 22 | 625-067P | 1 | BUSHING, STAND OFF | 48 | F-1158 | 4 | 1/4" LOCK NUT |
| 23 | 625-064P | 1 | BUSHING, PIVOT BLOCK | 49 | F-1539 | 3 | 1/4-20 X 1-1/4" HHCS GR. 5 |
| 24 | 625-072P | 1 | WASHER, FLAT | 50 | H-1987 | 1 | BUSHING, LARGE |
| 25 | F-1847 | 2 | GROMMET, #4 X 1/4" SQ. | 51 | H-1989 | 1 | BUSHING, SMALL |
| 26 | 625-065P | 1 | TOP PLATE, DUALEVER | 52 | H-1885 | 2 | BALL JOINT |

COUNTRY CLIPPER "ZETON" MOWER REPAIR PARTS MANUAL

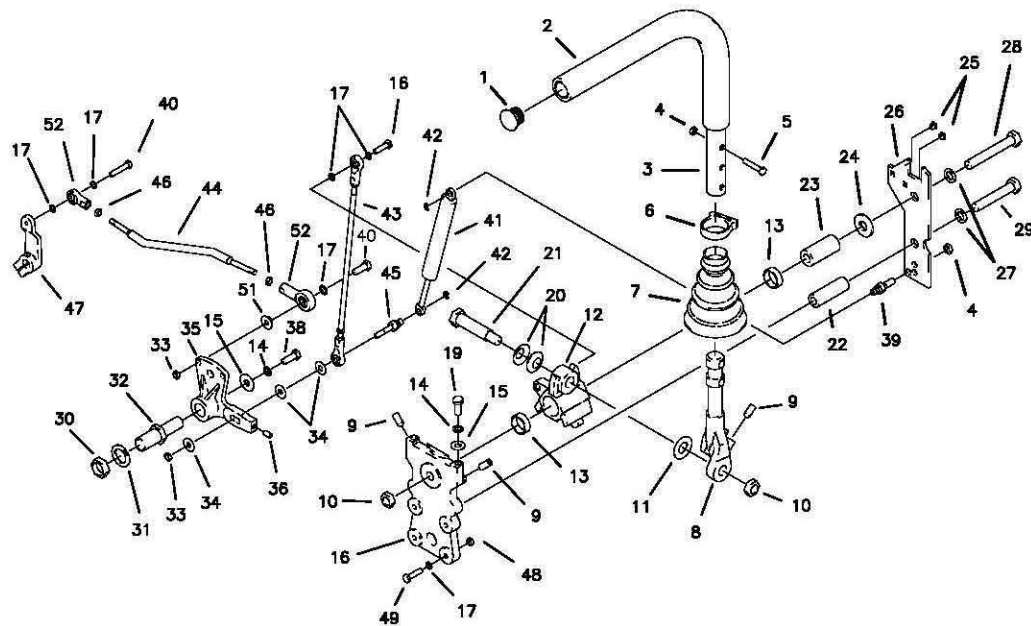
LEFT HAND STEERING
CONTROL AND RELATED
PARTS

| REF NO. | PART NO. | QTY. | DESCRIPTION | REF NO. | PART NO. | QTY. | DESCRIPTION |
|---------|-----------|------|-----------------------------|---------|-----------|------|-----------------------------|
| 1 | H-2080 | 1 | END PLUG, 15/16" BLACK | 27 | F-1464 | 2 | 1/2" LOCK WASHER |
| 2 | H-2079 | 1 | FOAM GRIP, 17" | 28 | F-1828 | 1 | 1/2-13 X 3-1/2" HHCS GR. 5 |
| 3 | 642-004A | 1 | CONTROL LEVER ASSEMBLY | 29 | F-1439 | 1 | 1/2-13 X 3" HHCS GR. 5 |
| 4 | F-1125 | 3 | 5/16 LOCK NUT | 30 | F-1011-07 | 1 | 3/4-10 PLAIN NUT |
| 5 | F-1015-17 | 2 | 5/16-18 X 1-1/2" HHCS GR. 5 | 31 | F-1463 | 1 | 3/4" LOCK WASHER |
| 6 | H-2089 | 1 | HOSE CLAMP | 32 | 623-048P | 1 | LINKAGE PINTLE |
| 7 | H-2081 | 1 | BOOT, TAPERED 1" CUFF | 33 | F-1158 | 1 | 1/4-20 LOCK NUT |
| 8 | 625-063P | 1 | LEVER, DUALEVER | 34 | F-1009-01 | 3 | 1/4" FLAT WASHER |
| 9 | F-1842 | 3 | SETScrew, 5/16-18 X 3/4" | 35 | 638-027A | 1 | LINKAGE DISK ASSEMBLY |
| 10 | F-1489 | 2 | 1/2-13 JAM NUT | 36 | F-1695 | 1 | SETSCREW, 1/4-20 X 3/8" |
| 11 | H-2118 | 1 | WASHER, FIBER | 37 | F-1011-01 | 1 | 1/4-20 PLAIN NUT |
| 12 | 638-033P | 1 | PIVOT BLOCK, DUALEVER | 38 | F-1015-14 | 1 | 5/16-18 X 7/8" HHCS GR. 5 |
| 13 | D-3622 | 2 | BEARING | 39 | 638-028P | 1 | DAMPER BOLT, 5-16-18 X 3/4" |
| 14 | F-1019-02 | 2 | 5/16" LOCK WASHER | 40 | F-1015-05 | 1 | 1/4-20 X 1" HHCS GR. 5 |
| 15 | F-1009-02 | 2 | WASHER, FLAT STD. 5/16" | 41 | H-2168 | 1 | STEERING DAMPER |
| 16 | 638-034P | 1 | BASE DUALEVER | 42 | F-1610 | 2 | E-RING FOR 1/4" SHAFT |
| 17 | F-1019-01 | 11 | 1/4" LOCK WASHER | 43 | H-2125 | 1 | UPPER LINKAGE |
| 18 | F-1015-05 | 1 | 1/4-20 X 1" HHCS GR. 5 | 44 | 647-024P | 1 | LOWER LINKAGE |
| 19 | F-1546 | 1 | 5/16-18 X 3/4" HHCS GR. 5 | 45 | 638-029P | 1 | DAMPER BOLT, 1/4-20 |
| 20 | H-2115 | 2 | WASHER, SPRING | 46 | F-1487 | 2 | NUT, HEX 1/4-28 UNF |
| 21 | 625-070P | 1 | SHOULDER BOLT, 5/8" OD | 47 | 625-026P | 1 | SHIFT ARM |
| 22 | 625-067P | 1 | BUSHING, STAND OFF | 48 | F-1158 | 4 | 1/4" LOCK NUT |
| 23 | 625-064P | 1 | BUSHING, PIVOT BLOCK | 49 | F-1539 | 3 | 1/4-20 X 1-1/4" HHCS GR. 5 |
| 24 | 625-072P | 1 | WASHER, FLAT | 50 | - | - | - |
| 25 | F-1847 | 2 | GROMMET, #4 X 1/4" SQ. | 51 | H-1989 | 1 | BUSHING, SMALL |
| 26 | 625-085P | 1 | TOP PLATE, DUALEVER | 52 | H-1885 | 2 | BALL JOINT |

COUNTRY CLIPPER "ZETON" MOWER REPAIR PARTS MANUAL

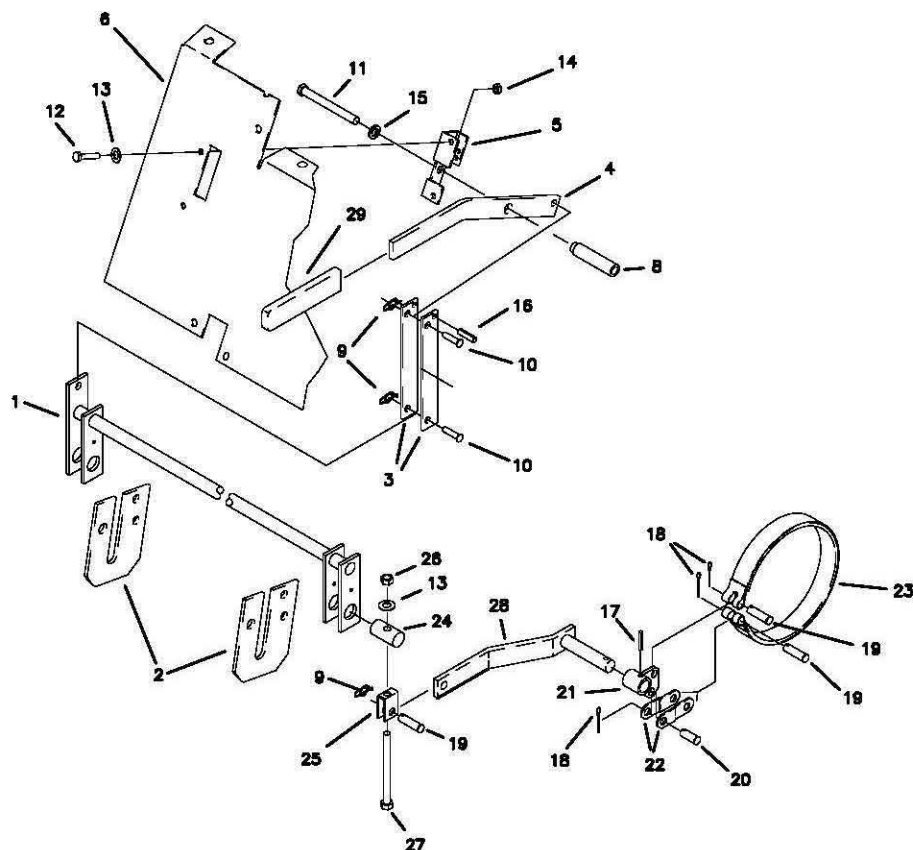
PARKING BRAKE ASSEMBLY
& RELATED PARTS

| REF NO. | PART NO. | QTY. | DESCRIPTION | REF NO. | PART NO. | QTY. | DESCRIPTION |
|---------|-----------|------|---------------------------|---------|----------|------|----------------------|
| 1 | 647-014W | 1 | BRAKE ROD WELDMENT | 21 | 647-029W | 1 | BRAKE ARM SHORT, LH. |
| 2 | 642-042P | 2 | BRAKE ROD MOUNT | - | 647-028W | 1 | BRAKE ARM SHORT, RH. |
| 3 | 642-058P | 2 | BRAKE LINK | 22 | 647-010P | 4 | BRAKE ANCHOR LINK |
| 4 | 642-056P | 1 | BRAKE HANDLE | 23 | D-3668 | 2 | BRAKE BAND |
| 5 | 642-054P | 1 | BRAKE SWITCH BRACKET | 24 | 642-067P | 2 | TOP HANGER PIN |
| 6 | 642-057P | 1 | FRONT PANEL | 25 | 647-030P | 2 | BRAKE YOKE LINKAGE |
| - | - | - | - | 26 | F-1125 | 2 | 5/16-18 LOCK NUT |
| 8 | 642-027P | 1 | BRAKE PIVOT TUBE | 27 | F-1682 | 2 | 5/16-18 X 4" GR. 5 |
| 9 | F-1492 | 3 | RUE RING | 28 | 647-013W | 1 | BRAKE ARM WLDT, LONG |
| 10 | F-1443 | 2 | 5/16" PIN | 29 | H-1926 | 1 | HANDLE GRIP |
| 11 | F-1827 | 1 | 3/8-16 X 3-1/2" GR. 5 | | | | |
| 12 | F-1538 | 2 | 1/4-20 X 3/4" GR. 5 | | | | |
| 13 | F-1009-01 | 4 | 1/4" FLAT WASHER | | | | |
| 14 | F-1005-01 | 2 | 1/4-20 LOCK NUT | | | | |
| 15 | F-1019-03 | 1 | 3/8" LOCK WASHER | | | | |
| 16 | F-1831 | 1 | 1/4 X 1" ROLL PIN | | | | |
| 17 | F-1553 | 2 | 3/16 X 7/8" ROLL PIN | | | | |
| 18 | F-1491 | 3 | COTTER PIN, 1/8 X 1" | | | | |
| 19 | F-1444 | 3 | CLEVIS PIN, 3/8 X 1-5/16" | | | | |
| 20 | F-1438 | 1 | CLEVIS PIN, 3/8 X 3/4" | | | | |

COUNTRY CLIPPER "ZETON" MOWER REPAIR PARTS MANUAL

GEAR MOTOR, WHEEL ASSEMBLY

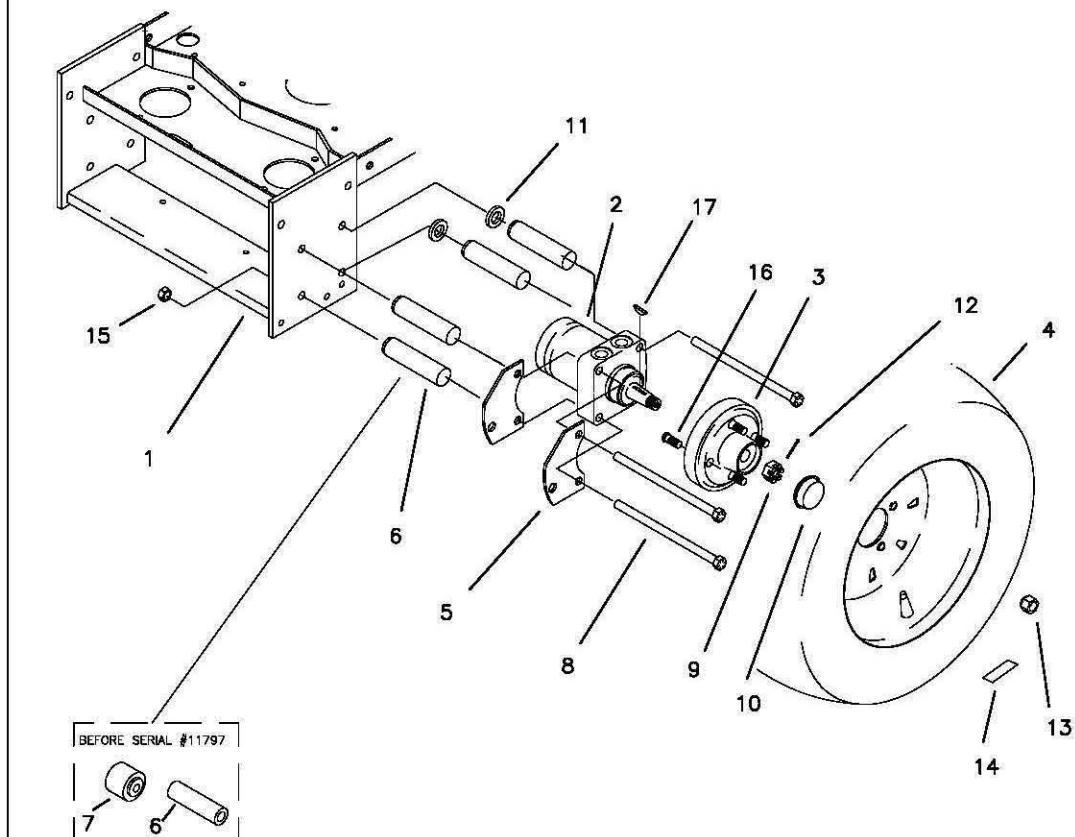

| REF NO. | PART NO. | QTY. | DESCRIPTION |
|---------|-----------|------|--|
| 1 | 647-003W | 1 | MOTOR MOUNT |
| 2 | D-3667 | 2 | WHEEL MOTOR |
| 3 | 647-041P | 2 | WHEEL HUB W/STUDS |
| 4 | D-3669 | 2 | TIRE/WHEEL ASSEMBLY 24" X 12"-12, 4PLY |
| 5 | 647-017P | 4 | BRAKE MOUNT PLATE |
| 6 | 647-039P | 8 | SPACER, LONG |
| 7 | 647-040P | 8 | SPACER, SHORT |
| 8 | F-1908 | 8 | CAPSCREW, 1/2-13 X 9" GR. B |
| 9 | F-1909 | 2 | NUT, 3/4-16 CASTLE NUT |
| 10 | H-1798 | 2 | GREASE CAP |
| 11 | 612-109P | 4 | WASHER |
| 12 | H-1376 | 2 | COTTER PIN, 1/8 X 1-1/2" |
| 13 | F-1499 | 8 | LUG NUT, 1/2-20 X 60 DEG. |
| 14 | P-10877 | 2 | DECAL, TIRE PRESSURE |
| 15 | F-1005-05 | 8 | 1/2-13 LOCK NUT |
| 16 | F-1654 | 8 | WHEEL STUD, (REPLACEMENT) |
| 17 | D-1004-01 | 1 | KEY, 1/4 X 1" WOODRUFF |

COUNTRY CLIPPER "ZETON" MOWER REPAIR PARTS MANUAL

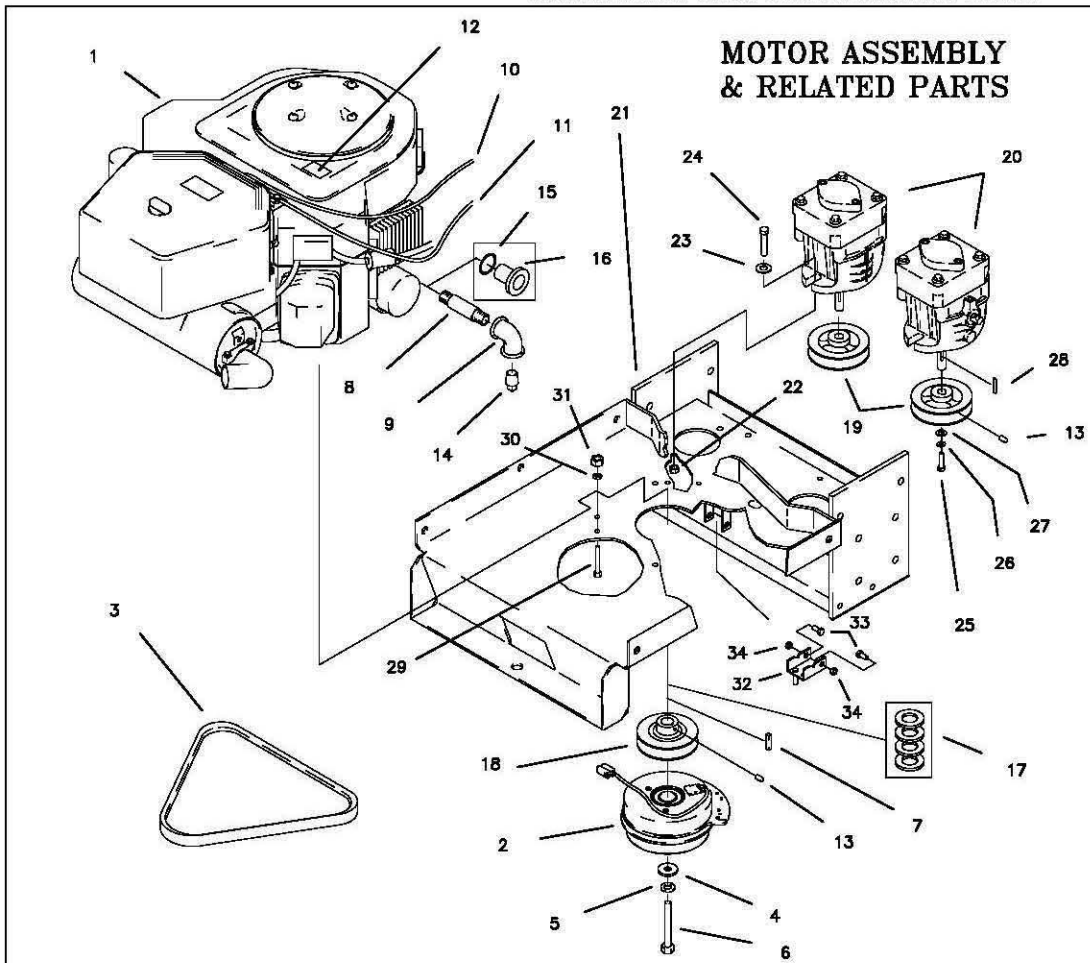

MOTOR ASSEMBLY & RELATED PARTS

| REF NO. | PART NO. | QTY. | DESCRIPTION | REF NO. | PART NO. | QTY. | DESCRIPTION |
|---------|-----------|------|---------------------------------|---------|-----------|------|-------------------------------|
| 1 | M-5316 | 1 | 25 HP. KOHLER ENGINE | 14 | H-1380 | 1 | PLUG, 3/8" NPT |
| - | M-5327 | 1 | 25 HP. KAWASAKI ENGINE | 15 | D-3446 | 1 | 3/4-16 PORT O-RING (KAWASAKI) |
| - | M-5328 | 1 | 26 HP E.F.I. KOHLER ENGINE | 16 | H-2285 | 1 | DRAIN ADAPTER (KAWASAKI) |
| - | M-5335 | 1 | 27 HP. KOHLER ENGINE | 17 | F-1009-01 | 4 | 1/4" FLAT WASHERS (KAWASAKI) |
| 2 | E-6247 | 1 | CLUTCH, MAGSTOP 1-1/8" | 18 | 647-036P | 1 | MOTOR PULLEY |
| - | E-6338 | 1 | CLUTCH, 200 FT. LB.(ZETON BOSS) | 19 | 647-035P | 2 | HYDRO PUMP PULLEY |
| 3 | D-3671 | 1 | HYDRO PUMP BELT | 20 | - | - | SEE PAGE 3-20 |
| 4 | 606-347P | 1 | WASHER | 21 | 647-005W | 1 | MOTOR MOUNT |
| 5 | F-1019-04 | 1 | 7/16 LOCK WASHER | 22 | F-1005-03 | 4 | NUT, 3/8-16 STOVER |
| 6 | F-1766 | 1 | 7/16-20 X 3-1/4" | 23 | F-1009-03 | 4 | 3/8 FLAT WASHER |
| - | F-1904 | 1 | 7/16-20 X 2-1/2" (KAWASAKI) | 24 | F-1307 | 4 | 3/8-16 X 1-1/4" GR. 5 |
| 7 | 621-113P | 1 | KEY, 1/4 SQ. X 1-1/4" | 25 | F-1737 | 2 | 6MM X 16MM GR. 5 |
| 8 | H-1343 | 1 | 3/8 X 4" PIPE NIPPLE | 26 | F-1738 | 2 | 6MM WASHER |
| - | H-1089 | 1 | 3/8 X 2" PIPE NIPPLE (KAWASAKI) | 27 | 620-187P | 2 | WASHER |
| 9 | H-1218 | 1 | 3/8" PIPE ELBOW | 28 | D-3541 | 2 | KEY, 5MM. |
| 10 | H-2235 | 1 | CHOKE CABLE | 29 | F-1015-17 | 3 | 5/16-18 X 1-1/2" GR. 5 |
| - | H-2287 | 1 | CHOKE CABLE (KAWASAKI) | 30 | F-1019-02 | 4 | 5/16" LOCK WASHER |
| - | H-2404 | 1 | CHOKE CABLE (27 HP KOHLER) | 31 | F-1011-02 | 4 | 5/16-18 PLAIN NUT |
| 11 | H-2236 | 1 | THROTTLE CABLE | 32 | 647-023W | 1 | CLUTCH STOP WELDMENT |
| - | H-2286 | 1 | THROTTLE CABLE (KAWASAKI) | 33 | F-1538 | 2 | 1/4-20 X 3/4" GR. 5 |
| 12 | P-10077 | 1 | DECAL, "CLEAN" | 34 | F-1158 | 2 | 1/4-20 LOCK NUTS |
| 13 | F-1228 | 3 | SETScrew, 1/4" X 1/4" | | | | |

COUNTRY CLIPPER "ZETON" MOWER REPAIR PARTS MANUAL

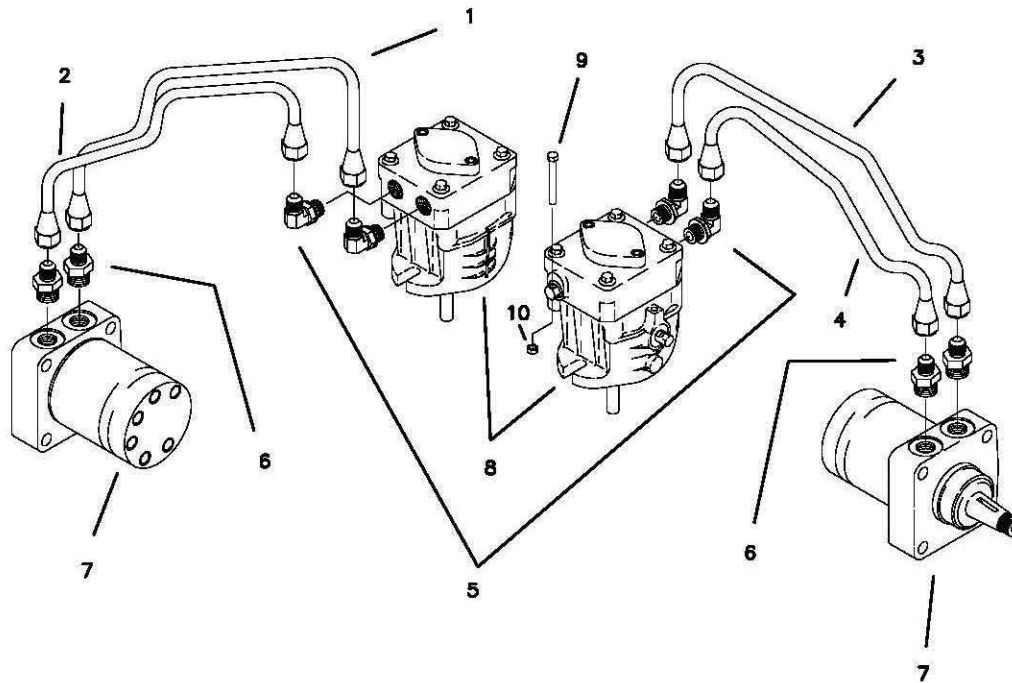
HIGH PRESSURE
LINES & FITTINGS

VIEWED FROM RIGHT REAR

| REF NO. | PART NO. | QTY. | DESCRIPTION |
|---------|----------|------|--------------------------------|
| 1 | H-2322 | 1 | TUBE ASS'Y, RH. FORWARD |
| 2 | H-2323 | 1 | TUBE ASS'Y, RH. REVERSE |
| 3 | H-2320 | 1 | TUBE ASS'Y, LH. FORWARD |
| 4 | H-2321 | 1 | TUBE ASS'Y, LH. REVERSE |
| 5 | H-2318 | 4 | FITTING, 90 DEG. ELBOW, 3/4-16 |
| 6 | H-2319 | 4 | FITTING, STRAIGHT, 7/8-14 |
| 7 | D-3667 | 2 | WHEEL MOTOR |
| 8 | D-3666 | 2 | HYDRAULIC PUMP |
| 9 | F-1077 | 2 | 1/4-20 X 2" GR. 5 (FOR HANDLE) |
| 10 | F-1158 | 2 | 1/4-20 LOCK NUT |

COUNTRY CLIPPER "ZETON" MOWER REPAIR PARTS MANUAL

OIL RETURN LINES & COOLER ASSEMBLY

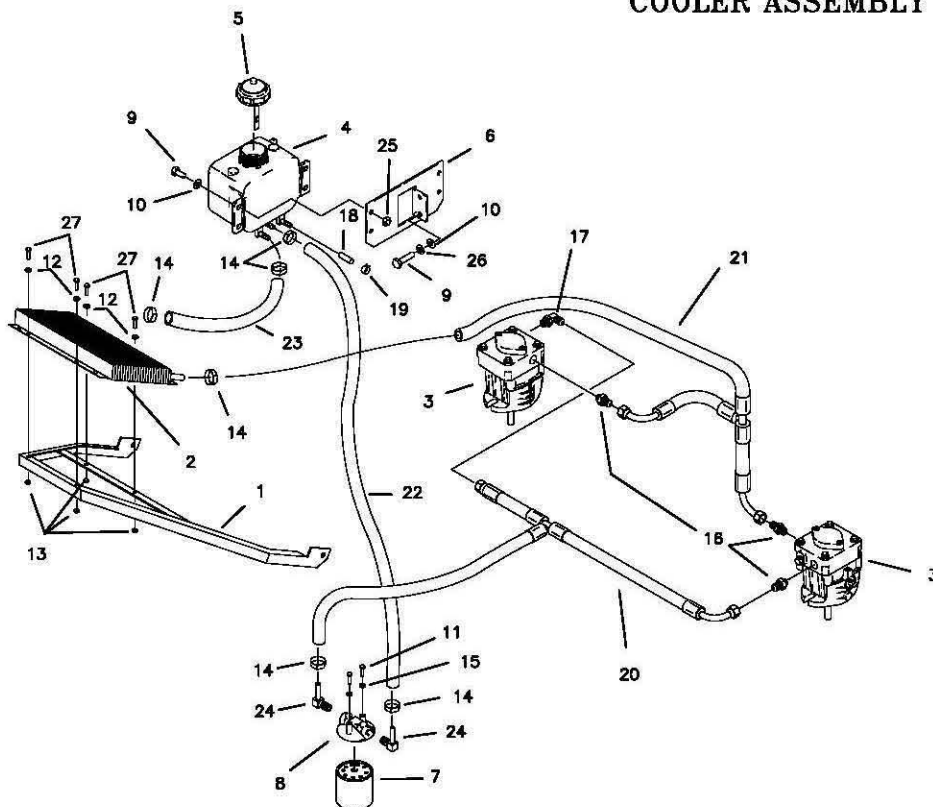

| REF NO. | PART NO. | QTY. | DESCRIPTION | REF NO. | PART NO. | QTY. | DESCRIPTION |
|---------|-----------|------|---------------------|---------|-----------|------|-----------------------------|
| 1 | 647-046W | 1 | BRACKET, OIL COOLER | 20 | H-2328 | 1 | HOSE, SUCTION |
| 2 | H-2325 | 1 | OIL COOLER | 21 | H-2329 | 1 | HOSE, RETURN |
| 3 | - | - | SEE PAGE 3-20 | 22 | H-2333 | 1 | HOSE, 18" HI-TEMP |
| 4 | H-2230 | 1 | TANK, 2 QUART | 23 | H-2332 | 1 | HOSE, 16" HI-TEMP |
| 5 | 644-035A | 1 | CAP, HYDRO TANK | 24 | H-1859 | 2 | ELBOW, 1/4 PIPE & HOSE BARB |
| 6 | 642-052P | 1 | TANK MOUNT BRACKET | 25 | F-1125 | 4 | 5/16-18 STOVER NUT |
| 7 | H-2026 | 1 | FILTER, HYDRO | 26 | F-1019-02 | 2 | 5/16- LOCK WASHER |
| 8 | H-2061 | 1 | FILTER BASE | 27 | F-1538 | 4 | 1/4-20 X 3/4" GR. 5 |
| 9 | F-1546 | 6 | 5/16 X 3/4 GR. 5 | | | | |
| 10 | F-1009-02 | 4 | 5/16 FLAT WASHER | | | | |
| 11 | F-1015-05 | 2 | 1/4-20 X 1" GR. 5 | | | | |
| 12 | F-1009-01 | 4 | 1/4" FLAT WASHER | | | | |
| 13 | F-1158 | 4 | 1/4" LOCK NUT | | | | |
| 14 | H-2282 | 6 | HOSE CLAMP | | | | |
| 15 | F-1019-01 | 2 | LOCK WASHER | | | | |
| 16 | H-2330 | 3 | ADAPTER | | | | |
| 17 | H-2331 | 1 | ELBOW | | | | |
| 18 | H-2327 | 1 | CAPLUG, 3/8 X 1" | | | | |
| 19 | H-1687 | 1 | HOSE CLAMP | | | | |

COUNTRY CLIPPER "ZETON" MOWER REPAIR PARTS MANUAL

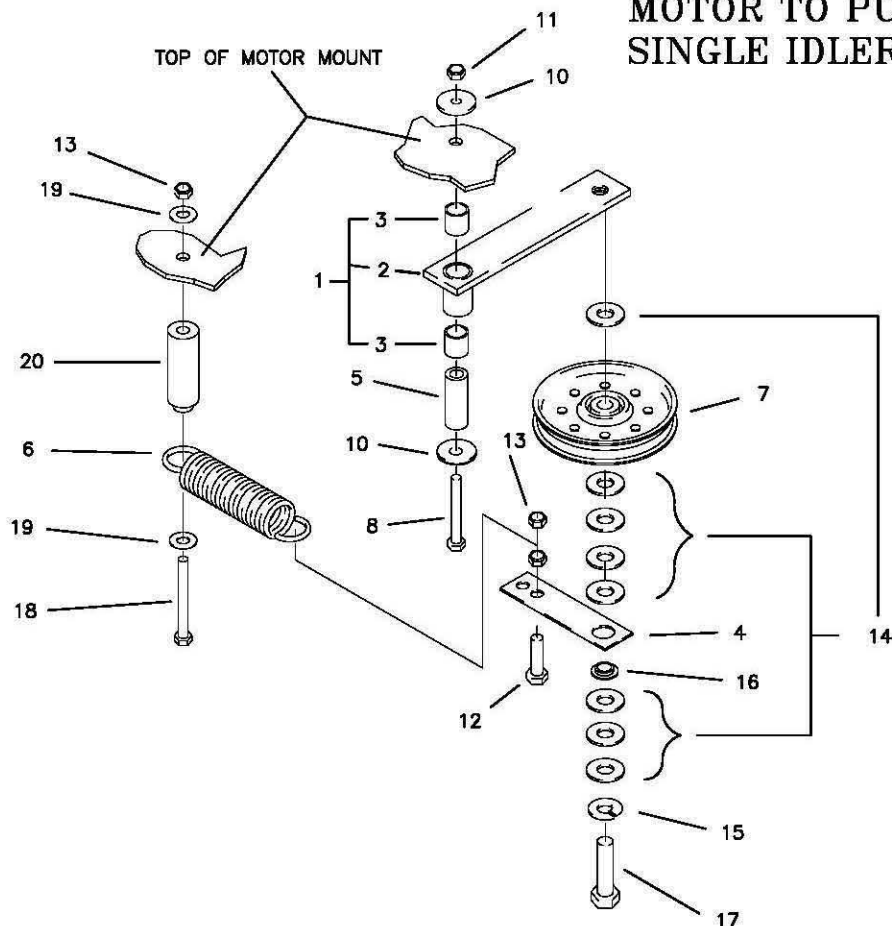
MOTOR TO PUMP
SINGLE IDLER

| REF NO. | PART NO. | QTY. | DESCRIPTION |
|---------|-----------|------|-----------------------------|
| 1 | 622-167A | 1 | SINGLE IDLER ASSEMBLY |
| 2 | 622-051W | 1 | SINGLE IDLER WELDMENT |
| 3 | D-3573 | 2 | BUSHING, DX 5/8 X 3/4" |
| 4 | 622-047P | 1 | SPRING EXTENSION |
| 5 | 621-103P | 1 | MOUNTING PIN |
| 6 | H-2092 | 1 | SPRING |
| 7 | D-3617 | 1 | FLAT IDLER PULLEY |
| 8 | F-1820 | 1 | 5/16-18 X 2-1/4" HHCS GR. 5 |
| - | - | - | - |
| 10 | F-1009-02 | 2 | 5/16" FLAT WASHER |
| 11 | F-1125 | 1 | 5/16 LOCK NUT |
| 12 | F-1445 | 1 | 3/8-24 X 1" HHCS GR. 5 |
| 13 | F-1573 | 3 | 3/8-24 LOCK NUT |
| 14 | F-1521 | 8 | 1/2" FLAT WASHER |
| 15 | F-1464 | 1 | 1/2" LOCK WASHER |
| 16 | 622-048P | 1 | IDLER STAND |
| 17 | F-1293 | 1 | 1/2-13 X 2" GR. 5 |
| 18 | F-1066 | 1 | 3/8-16 X 4" GR.5 |
| 19 | F-1009-03 | 2 | 3/8 FLAT WASHER |
| 20 | 642-163P | 1 | SPRING ANCHOR BUSHING |

COUNTRY CLIPPER "ZETON" MOWER REPAIR PARTS MANUAL

WIRE HARNESS & RELATED PARTS

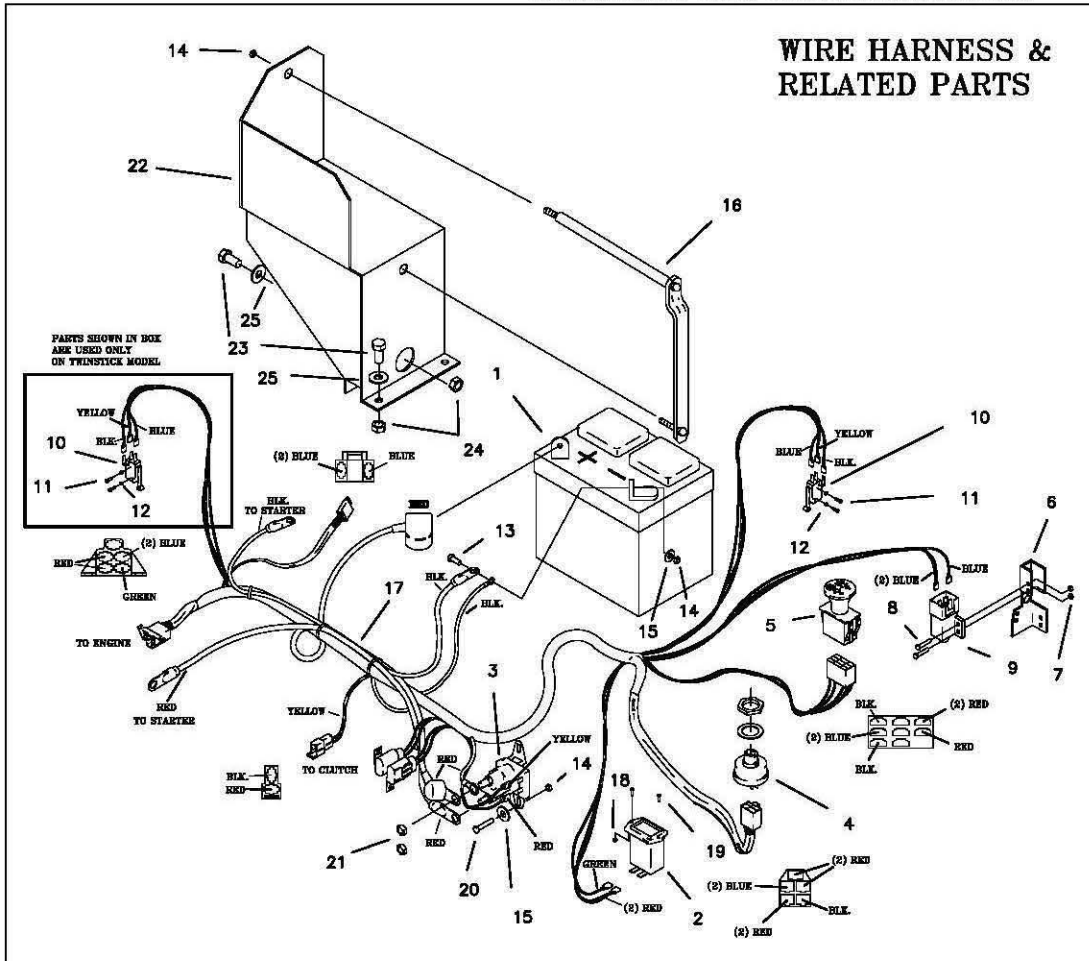

| REF NO. | PART NO. | QTY. | DESCRIPTION |
|---------|-----------|------|----------------------------|
| 1 | E-5812 | 1 | BATTERY USED ON 23 HP. |
| - | E-6271 | 1 | BATTERY USED ON 25 HP. |
| - | E-6271 | 1 | BATTERY USED ON 26 HP. EFI |
| 2 | E-5878 | 1 | HOUR METER |
| 3 | E-6054 | 1 | SOLENOID |
| 4 | E-5873 | 1 | START SWITCH |
| 5 | E-6296 | 1 | CLUTCH SWITCH |
| 6 | 642-054P | 1 | BRAKE SWITCH BRACKET |
| 7 | F-1448 | 2 | 8-32 LOCK NUT |
| 8 | F-1022-26 | 2 | 8-32 X 5/8 SCREW |
| 9 | E-6297 | 1 | BRAKE SWITCH |
| 10 | E-6074 | 1 | SWITCH, SPDT MINI |
| - | E-6074 | 2 | USED ON TWINSTICK |
| 11 | F-1396 | 2 | 4-40 X 3/4 SCREW |
| - | F-1396 | 4 | USED ON TWINSTICK |
| 12 | F-1621 | 2 | STAR WASHER |
| - | F-1621 | 4 | USED ON TWINSTICK |
| 13 | F-1538 | 2 | 1/4-20 X 3/4" GR. 5 |
| 14 | F-1158 | 5 | 1/4-20 LOCK NUT |
| 15 | F-1009-01 | 4 | 1/4" FLAT WASHER |
| 16 | 647-006A | 1 | BATTERY HOLD DOWN |

| REF NO. | PART NO. | QTY. | DESCRIPTION |
|---------|-----------|------|--|
| 17 | E-6298 | 1 | WIRE HARNESS |
| 18 | F-1535 | 2 | 6-32 LOCK NUT |
| 19 | F-1054 | 2 | 6-32 X 5/8" MACHINE SCREW |
| 20 | F-1015-02 | 2 | 1/4-20 X 5/8" GR. 5 |
| 21 | F-1567 | 2 | 5/16-24 NUT |
| - | E-6281 | 1 | COVER (KEY SWITCH) -NOT SHOWN- |
| - | E-6307 | 1 | OIL PRESSURE SWITCH (2305KA ONLY) -NOT SHOWN- |
| - | E-6309 | 1 | WIRE HARNESS ADAPTER (2305KA ONLY) -NOT SHOWN- |
| 22 | 647-008W | 1 | BATTERY BOX |
| 23 | F-1015-15 | 3 | 5/16-18 X 1" GR. 5 |
| 24 | F-1125 | 3 | 5/16-18 LOCK NUT |
| 25 | F-1009-02 | 3 | 5/16 FLAT WASHER |

COUNTRY CLIPPER "ZETON" MOWER REPAIR PARTS MANUAL

EFI WIRE HARNESS & RELATED PARTS

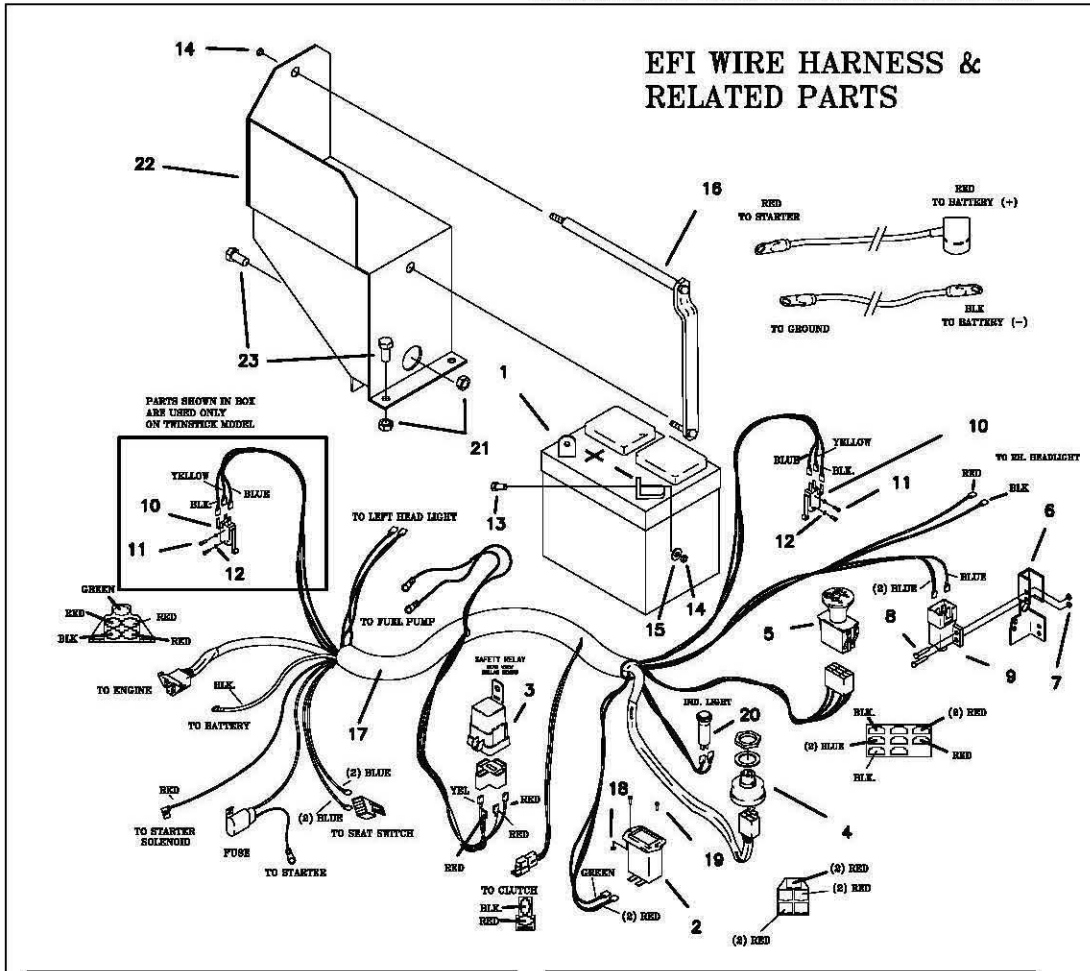

| REF NO. | PART NO. | QTY. | DESCRIPTION |
|---------|-----------|------|----------------------------|
| 1 | E-5812 | 1 | BATTERY USED ON 23 HP. |
| - | E-6271 | 1 | BATTERY USED ON 25 HP. |
| - | E-6271 | 1 | BATTERY USED ON 26 HP. EFI |
| 2 | E-5878 | 1 | HOUR METER |
| 3 | E-6277 | 1 | SAFETY RELAY |
| 4 | E-5873 | 1 | START SWITCH |
| 5 | E-6296 | 1 | CLUTCH SWITCH |
| 6 | 642-054P | 1 | BRAKE SWITCH BRACKET |
| 7 | F-1448 | 2 | 8-32 LOCK NUT |
| 8 | F-1022-26 | 2 | 8-32 X 5/8 SCREW |
| 9 | E-6297 | 1 | BRAKE SWITCH |
| 10 | E-6074 | 1 | SWITCH, SPDT MINI |
| - | E-6074 | 2 | USED ON TWINSTICK |
| 11 | F-1396 | 2 | 4-40 X 3/4 SCREW |
| - | F-1396 | 4 | USED ON TWINSTICK |
| 12 | F-1621 | 2 | STAR WASHER |
| - | F-1621 | 4 | USED ON TWINSTICK |
| 13 | F-1538 | 2 | 1/4-20 X 3/4" GR. 5 |
| 14 | F-1158 | 3 | 1/4-20 LOCK NUT |
| 15 | F-1009-01 | 2 | 1/4" FLAT WASHER |
| 16 | 647-006A | 1 | BATTERY HOLD DOWN |

| REF NO. | PART NO. | QTY. | DESCRIPTION |
|---------|-----------|------|--|
| 17 | E-6313 | 1 | E.F.I. WIRE HARNESS |
| 18 | F-1535 | 2 | 6-32 LOCK NUT |
| 19 | F-1054 | 2 | 6-32 X 5/8" MACHINE SCREW |
| 20 | E-6314 | 1 | INDICATOR LIGHT |
| 21 | F-1567 | 3 | 5/16-24 NUT |
| | E-6281 | 1 | COVER (KEY SWITCH) -NOT SHOWN- |
| | E-6307 | 1 | OIL PRESSURE SWITCH (2305KA ONLY) -NOT SHOWN- |
| | E-6309 | 1 | WIRE HARNESS ADAPTER (2305KA ONLY) -NOT SHOWN- |
| 22 | 647-008W | 1 | BATTERY BOX |
| 23 | F-1015-15 | 3 | 5/16-18 X 1" GR. 5 |

COUNTRY CLIPPER "ZETON" MOWER REPAIR PARTS MANUAL

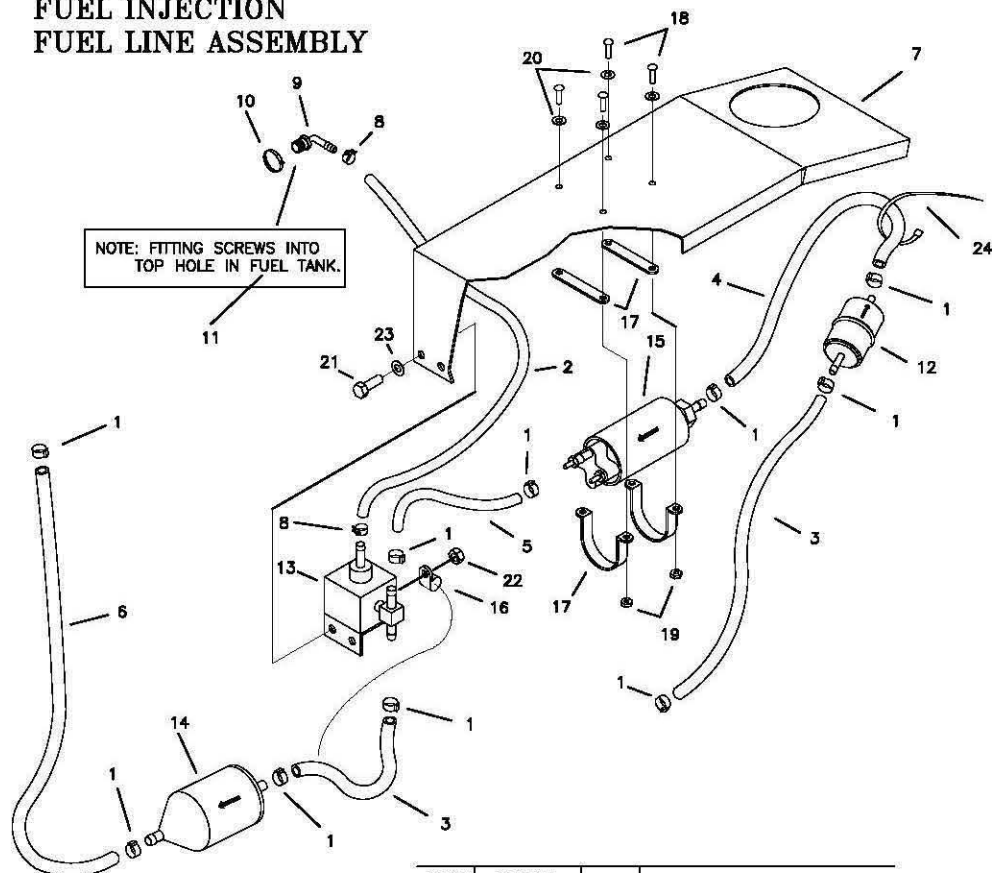
FUEL INJECTION
FUEL LINE ASSEMBLY

| REF NO. | PART NO. | QTY. | DESCRIPTION |
|---------|-----------|------|------------------------------|
| 1 | H-2336 | 10 | HOSE CLAMP |
| 2 | 647-063P | 1 | 46" FUEL LINE, 1/4" ID |
| 3 | 647-059P | 1 | 7" FUEL LINE, 5/16" ID |
| 4 | 647-060P | 1 | 14" FUEL LINE, 5/16" ID |
| 5 | 647-061P | 1 | 5" FUEL LINE, 5/16" ID |
| 6 | 647-062P | 1 | 16" FUEL LINE, 5/16" ID |
| 7 | - | 1 | FENDER CAP RH |
| 8 | H-1687 | 2 | HOSE CLAMP |
| 9 | H-1646 | 1 | HOSE BARB |
| 10 | H-1952 | 1 | HOSE CLAMP |
| 11 | 647-058P | 1 | FUEL TANK FOR EFI |
| 12 | H-2335 | 1 | FUEL FILTER |
| 13 | H-2339 | 1 | REGULATOR |
| 14 | H-2338 | 1 | FILTER, BOSCH |
| 15 | H-2340 | 1 | FUEL PUMP |
| 16 | H-2337 | 1 | LOOP CLAMP |
| 17 | H-2341 | 2 | PUMP MOUNTING BANDS & BARS |
| 18 | F-1022-26 | 4 | MACHINE SCREWS, 10-32 X 5/8" |
| 19 | F-1448 | 4 | 10-32 LOCK NUT |
| 20 | F-1071 | 4 | FLAT WASHER |
| 21 | F-1538 | 2 | 1/4-20 X 3/4" GR 5 |
| 22 | F-1158 | 2 | 1/4" LOCK NUT |
| 23 | F-1009-01 | 2 | 1/4" FLAT WASHER |
| 24 | E-5884 | 1 | WIRE TIE |