

COUNTRY CLIPPER "ZETON BRAT" ZERO TURN RADIUS MOWER

TABLE OF CONTENTS

PAGE.... CONTENTS

SECTION 1 – MOWER DECKS AND RELATED PARTS

- 1-1. . . . 42" DECK ASSEMBLY
- 1-2. . . . 48" DECK ASSEMBLY
- 1-3. . . . DECK SPINDLE ASSEMBLY
- 1-4. . . . DRIVE BELT IDLER & RELATED PARTS
- 1-5. . . . LIFT HANDLE ASSEMBLY & RELATED PARTS
- 1-6LIFT ASSEMBLY & RELATED PARTS
- 1-7. . . . DOUBLE IDLER & RELATED PARTS

SECTION 2 –TRACTOR FRAME AND RELATED PARTS

- 2-8.CASTER WHEEL ASSEMBLY
- 2-9.FRAME SIDES & RELATED PARTS
- 2-10. . . .FENDER ASSEMBLY
- 2-11. . . .SEAT, FOOT DECK & RELATED PARTS

SECTION 3 –TRACTOR DRIVE AND RELATED PARTS

- 3-12. . . .FUEL TANK ASSEMBLY
- 3-13. . . .JOYSTICK STEERING CONTROL & RELATED PARTS
- 3-14. . . .JOYSTICK STEERING CONTROL & RELATED PARTS (continued)
- 3-15. . . .RIGHT HAND STEERING CONTROL & RELATED PARTS
- 3-16. . . .LEFT HAND STEERING CONTROL & RELATED PARTS
- 3-17. . . .PARKING BRAKE ASSEMBLY & RELATED PARTS
- 3-18. . . .GEAR MOTOR WHEEL ASSEMBLY
- 3-19. . . .MOTOR ASSEMBLY & RELATED PARTS
- 3-20. . . .HIGH PRESSURE LINES & FITTINGS
- 3-21. . . .OIL RETURN LINES & COOLER ASSEMBLY
- 3-22. . . .MOTOR TO PUMP SINGLE IDLER
- 3-23. . . .WIRE HARNESS & RELATED PARTS

42" DECK ASSEMBLY

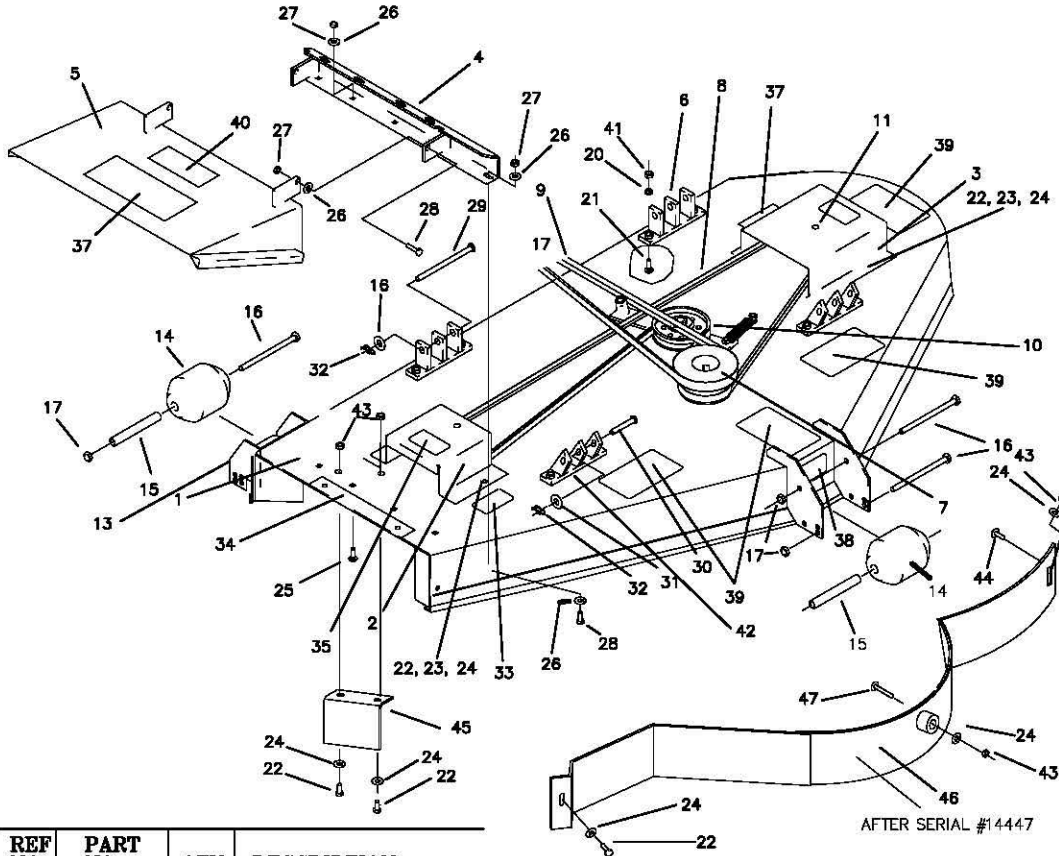

REF NO.	PART NO.	QTY.	DESCRIPTION
1	651-016A	1	42" DECK W/DECALS
2	651-018A	1	PULLEY COVER RH, W/DECAL
3	643-035A	1	PULLEY COVER LH, W/DECAL
4	637-053W	1	OUTLET STIFFENER
5	637-066A	1	42" DECK CHUTE W/DECAL
6	643-016W	4	DECK HANGER
7	609B-156P	1	PULLEY, 4 1/2" DIA. 2 GROOVE
8	D-3684	1	V-BELT (KEVLAR) A-B4
9	D-3692	1	V-BELT, MOTOR TO DECK
10	-----	1	SINGLE IDLER ASSEMBLY (SEE BREAK-DOWN PAGE)
11	-----	1	SPINDLE ASSEMBLY (SEE BREAK-DOWN PAGE)
13	609-182P	1	REAR SCALPER BRACKET
14	H-1948	2	ROLLER, 3-3/4 DIA. X 4-13/16
15	609-183P	2	WHEEL BUSHING
16	F-1741	4	3/8-16 X 6" GR. 5
17	F-1239	16	3/8 LOCKNUT
18	F-1009-03	11	3/8 FLAT WASHER
19	F-1558	4	3/8-16 X 7/8 GR. 5
20	F-1019-03	8	3/8" LOCKWASHER
21	F-1672	8	CARRIAGE BOLT, 5/16 X 1-1/4
22	F-1538	7	1/4-20 X 3/4 GR. 5
23	F-1019-01	4	1/4" LOCKWASHER

REF NO.	PART NO.	QTY.	DESCRIPTION
24	F-1009-01	9	1/4" FLAT WASHER
25	F-1671	4	CARRIAGE BOLT 5/16 X 3/4
26	F-1009-02	8	5/16" FLAT WASHER
27	F-1125	7	5/16-18 LOCKNUT
28	F-1015-15	3	5/16-18 X 1" GR. 5
29	H-2240	2	PIN, 1/2" X 4-1/2"
30	F-1889	2	PIN, 1/2" X 2-1/2"
31	F-1521	4	1/2" FLAT WASHER
32	H-2239	4	RUE RING 1/2"
33	P-10947	1	DECAL, "GREASE SPINDLE"
34	P-10122	1	DECAL, "MISSING CHUTE"
35	P-10935	2	DECAL, "ROTATING..."
37	P-10941	2	DECAL, "MULTI PERIL"
38	P-11413	1	DECAL, "HOIST POINT"
39	H-1932	4	SAFETY TREAD
40	P-10937	1	DECAL, "WARNING"
41	F-1005-03	8	LOCKNUT, 3/8 STOVER
42	651-009W	2	DECK HANGER
43	F-1158	4	1/4-20 LOCKNUT
44	F-1823	1	CARRIAGE BOLT, 1/4 X 3/4
45	651-023P	1	AIR BAFFLE
46	651-022W	1	DUST BAFFLE WLDT, 42"
47	F-1935	1	CARRIAGE BOLT, 1/4 X 1 1/2

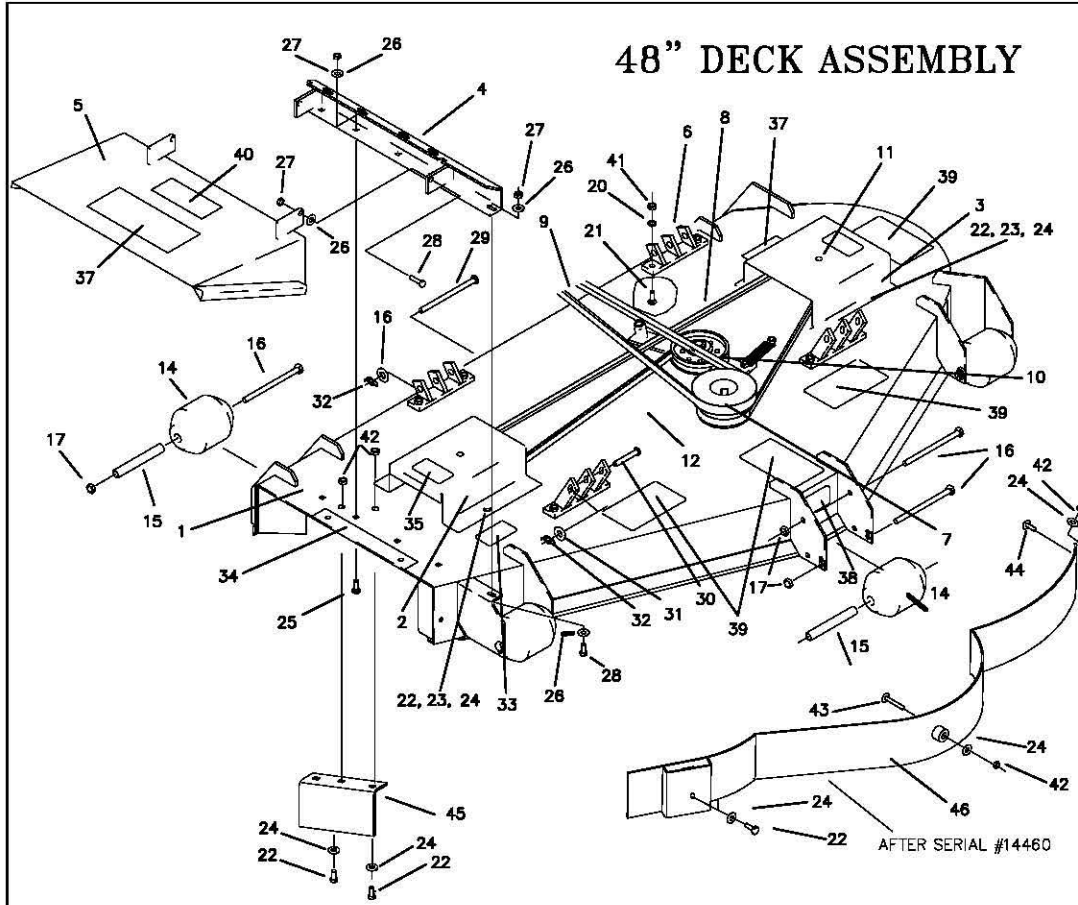

REF NO.	PART NO.	QTY.	DESCRIPTION
1	651-017A	1	48" DECK WLDT, W/DECALS
2	643-034A	1	PULLEY COVER RH, W/DECAL
3	643-035A	1	PULLEY COVER LH, W/DECAL
4	637-053W	1	OUTLET STIFFENER
5	637-066A	1	48" DECK CHUTE W/DECAL
6	651-009W	4	DECK HANGER
7	609A-156P	1	PULLEY, 4" DIA. 2 GROOVE
8	D-3635	1	V-BELT (KEVLAR) A-100
9	D-3686	1	V-BELT, MOTOR TO DECK
10	-----	1	SINGLE IDLER ASSEMBLY (SEE BREAK-DOWN PAGE)
11	-----	1	SPINDLE ASSEMBLY (SEE BREAK-DOWN PAGE)
12	-----	1	DRIVE BELT IDLER (SEE BREAK-DOWN PAGE)
13	609-182P	1	REAR SCALPER BRACKET
14	H-1948	5	ROLLER, 3-3/4 DIA. X 4-13/16
15	609-183P	5	WHEEL BUSHING
16	F-1741	6	3/8-16 X 6" GR. 5
17	F-1239	11	3/8 LOCKNUT
18	F-1009-03	4	3/8 FLAT WASHER
19	F-1558	4	3/8-16 X 7/8 GR. 5
20	F-1019-03	8	3/8" LOCKWASHER
21	F-1672	8	CARRIAGE BOLT, 5/16 X 1-1/4

REF NO.	PART NO.	QTY.	DESCRIPTION
22	F-1538	7	1/4-20 X 3/4 GR. 5
23	F-1019-01	4	1/4" LOCKWASHER
24	F-1009-01	9	1/4" FLAT WASHER
25	F-1671	4	CARRIAGE BOLT 5/16 X 3/4
26	F-1009-02	8	5/16" FLAT WASHER
27	F-1125	7	5/16-18 LOCKNUT
28	F-1015-15	3	5/16-18 X 1" GR. 5
29	H-2240	2	PIN, 1/2" X 4-1/2"
30	F-1889	2	PIN, 1/2" X 2-1/2"
31	F-1521	4	1/2" FLAT WASHER
32	H-2239	4	RUE RING 1/2"
33	P-10947	1	DECAL, "GREASE SPINDLE"
34	P-10122	1	DECAL, "MISSING CHUTE"
35	P-10935	2	DECAL, "ROTATING..."
37	P-10941	2	DECAL, "MULTI PERIL"
38	P-11413	1	DECAL, "HOIST POINT"
39	H-1932	4	SAFETY TREAD
40	P-10937	1	DECAL, "WARNING"
41	F-1005-03	8	LOCKNUT, 3/8 STOVER
42	F-1158	4	LOCKNUT, 1/4-20
43	F-1935	1	CARRIAGE BOLT, 1/4 X 1 1/2
44	F-1823	1	CARRIAGE BOLT, 1/4 X 3/4
45	629-230P	1	AIR BAFFLE
46	629-241W	1	DUST BAFFLE WLDT, 48"

DECK SPINDLE ASSEMBLY

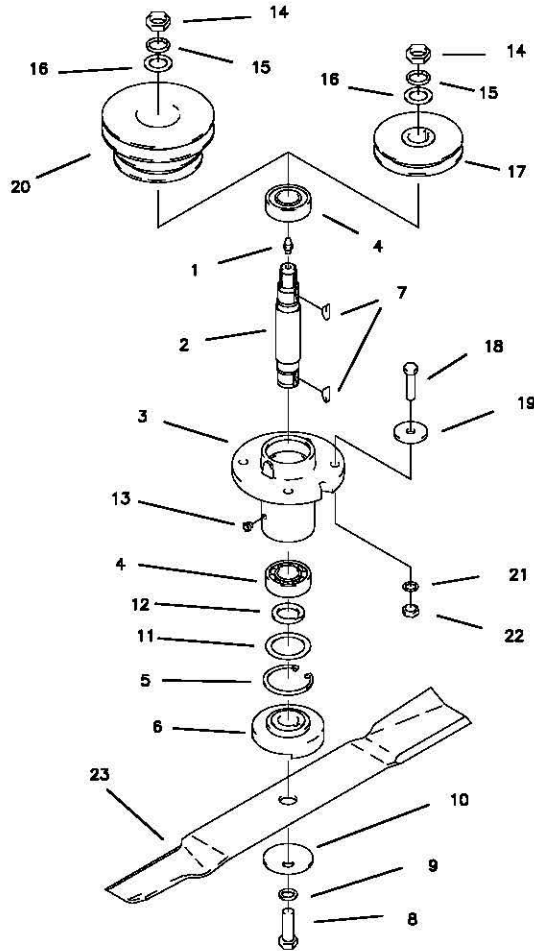

REF NO.	PART NO.	QTY.	DESCRIPTION	REF NO.	PART NO.	QTY.	DESCRIPTION
-	609F-019A	-	SPINDLE ASSEMBLY	16	F-1510	1	3/4" WASHER, FLAT STD.
1	H-1056	1	GREASE FITTING	17	609-155P	-	PULLEY, 1 GROOVE 4"
2	609-162P	1	SPINDLE SHAFT	18	F-1572	4	3/8-24 X 1-1/2" HHCS GR. 5
3	609-223P	1	SPINDLE HOUSING	19	609-034P	4	SPINDLE SPACER REINFORCEMENT
4	D-3058	2	BEARING, #6205-2RS	20	609B-156P	1	PULLEY, 2 GROOVE 42"
5	H-1893	1	SNAP RING INT. 52MM	-	609A-156P	-	PULLEY, 2 GROOVE 48"
6	609-152P	1	BLADE SPACER	21	F-1019-03	4	3/8" LOCK WASHER
7	D-1004-02	2	KEY, WOODRUF, 1/4 X 3/4	22	F-1573	4	3/8-24 LOCKNUT, M-F
8	F-1526	1	1/2-13 X 1-1/2" HHCS GR. 5	23	H-1666	1	BLADE, LOW L, 17" CUT 48"
9	F-1464	1	1/2" LOCK WASHER	-	H-1665	-	BLADE, LOW L, 15" CUT 42"
10	F-1507	1	WASHER, 1/2" CUPPED				
11	609-151P	1	WASHER, SEAL				
12	609-073P	1	ARBOR SPACER				
13	H-2066	1	GREASE VENT 5 LBS.	H-1714		-	OPTIONAL BLADES
14	F-1461	1	3/4-16 NUT, HEX JAM	H-1715		-	BLADE, HIGH L, 17" CUT 48"
15	F-1463	1	3/4" LOCK WASHER				BLADE, HIGH L, 15" CUT 42"

DRIVE BELT IDLER & RELATED PARTS

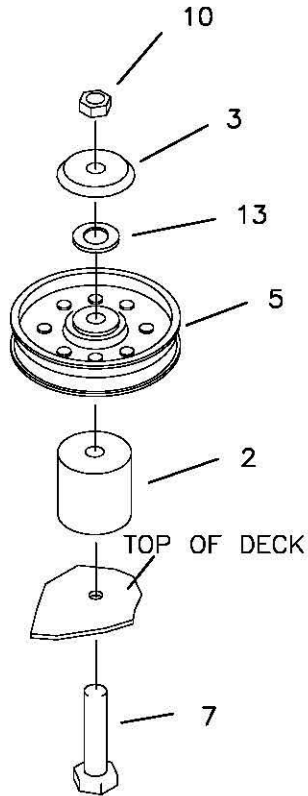

SINGLE IDLER ASSEMBLY & RELATED PARTS

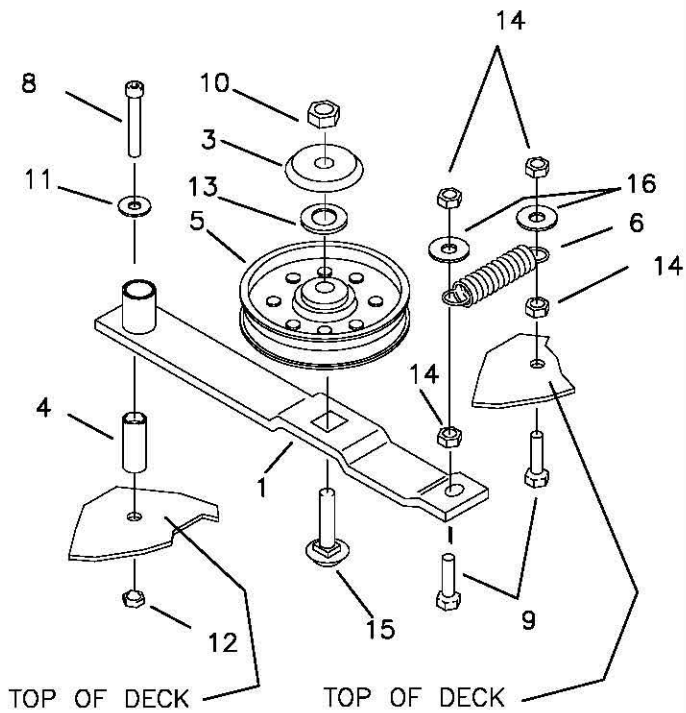

REF NO.	PART NO.	QTY.	DESCRIPTION
1	643-007W	1	SINGLE IDLER, 42" DECK
-	637-025W	-	SINGLE IDLER, 48" DECK
2	643-010P	1	SPACER, 2" DIA. X 2"
3	620-201P	2	BEARING CAP
4	621-103P	1	PIN
5	D-3338	2	PULLEY, FLAT IDLER
6	H-2092	1	SPRING, 1-1/2" X 5"
7	F-1779	1	1/2-13 X 4" GR. 5
8	F-1800	1	5/16-18 SHCS X 2-1/4"
9	F-1574	2	3/8-24 X 1-1/4" GR. 5
10	F-1378	2	1/2-13 LOCKNUT
11	F-1009-02	1	5/16 FLAT WASHER
12	F-1125	1	5/16 LOCK NUT
13	F-1521	2	1/2" FLAT WASHER
14	F-1573	3	3/8" LOCK NUT
15	F-1822	1	CARRIAGE BOLT, 1/2 X 2 1/4"
16	609-034P	2	REINFORCEMENT WASHER

LIFT HANDLE ASSEMBLY & RELATED PARTS

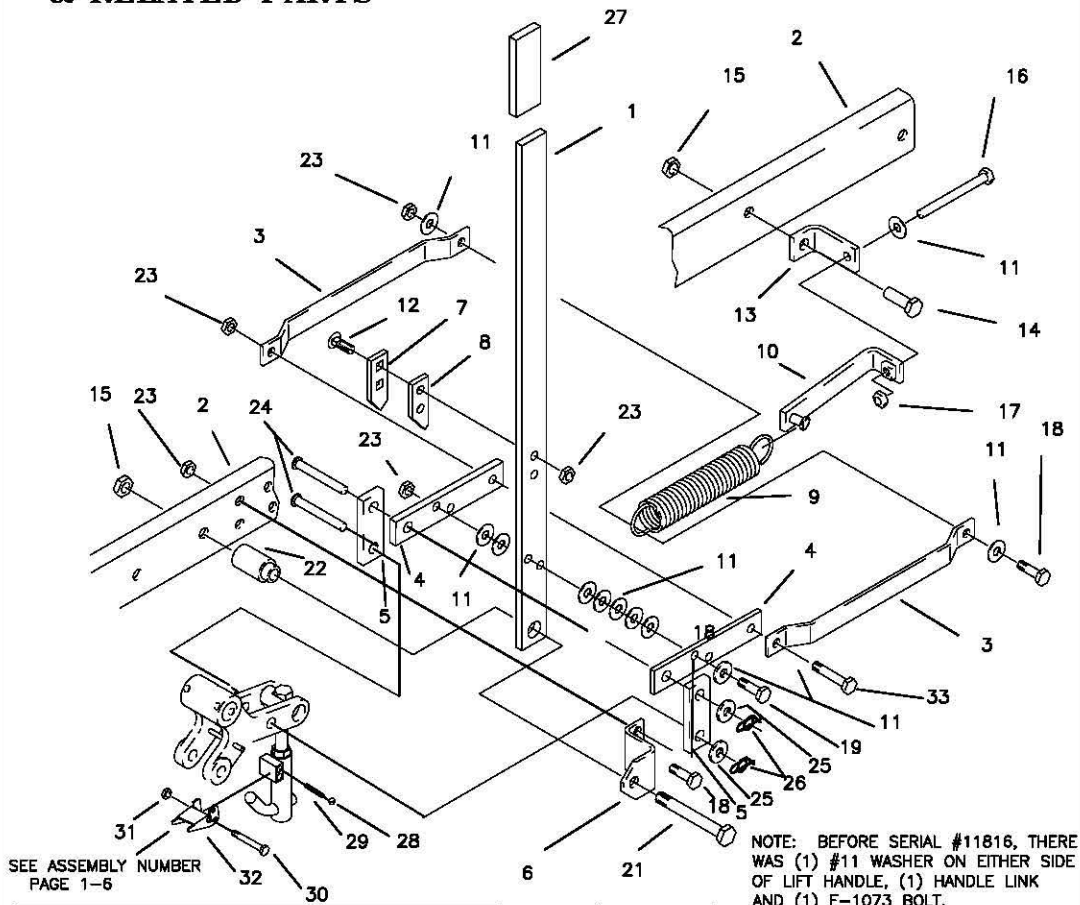

SEE ASSEMBLY NUMBER
PAGE 1-6

NOTE: BEFORE SERIAL #11816, THERE WAS (1) #11 WASHER ON EITHER SIDE OF LIFT HANDLE, (1) HANDLE LINK AND (1) F-1073 BOLT.

REF NO.	PART NO.	QTY.	DESCRIPTION	REF NO.	PART NO.	QTY.	DESCRIPTION
1	642-062P	1	LIFT HANDLE	21	F-1828	1	1/2-13 X 3-1/2" GR. 5
2	642-040W	1	FRAME WELDMENT, LH.	22	642-095P	1	HANDLE PIVOT PIN
3	642-055P	2	SPRING EXTENSION	23	F-1005-03	7	NUT, 3/8-16 LOCKNUT (STOVER)
4	642-060P	2	SPRING ANCHOR PLATE	24	F-1889	2	CLEVIS PIN, 1/2 X 2-5/8"
5	642-061P	2	HANDLE LINK	25	F-1521	2	1/2" FLAT WASHER
6	642-041P	1	HANDLE PIVOT BRACKET	26	H-2239	2	RUE RING, 1/2"
7	642-127P	1	TOP PEG LATCH PLATE	27	H-2324	1	VINYL GRIP, 3/8 X 1-1/2"
8	642-126P	1	TOP PEG SPACER PLATE	28	D-3723	1	1/4" CHROME STEEL BALL
9	H-1610	1	SPRING, 1-1/2" OD. X 8"	29	H-2390	1	SPRING, .219 OD X .024 WIRE
10	620-227W	1	SPRING TIGHTENER WLDT.	30	F-1716	1	1/4 X 1-1/2" , G.5
11	F-1009-03	11	FLAT WASHER, 3/8"	31	F-1158	1	NUT, 1/4" STOVER
12	F-1672	2	CARRIAGE BOLT, 3/8-16 X 1-1/4"	32	642-178P	1	LATCH
13	642-071W	1	SPRING ANCHOR WELDMENT	33	F-1015-30	1	3/8-16 X 2 1/2" GR. 5
14	F-1526	1	3/8-16 X 1-1/2" GR. 5				
15	F-1005-05	2	NUT, 1/2-13 LOCKNUT				
16	F-1646	1	3/8-16 X 5" FULL THREAD				
17	F-1011-03	3	HEX NUT, 3/8-16 UNC-2B				
18	F-1307	3	3/8-16 X 1-1/4" GR. 5				
19	F-1073	3	3/8-16 X 2" GR. 5				

**LIFT ASSEMBLY
& RELATED PARTS**

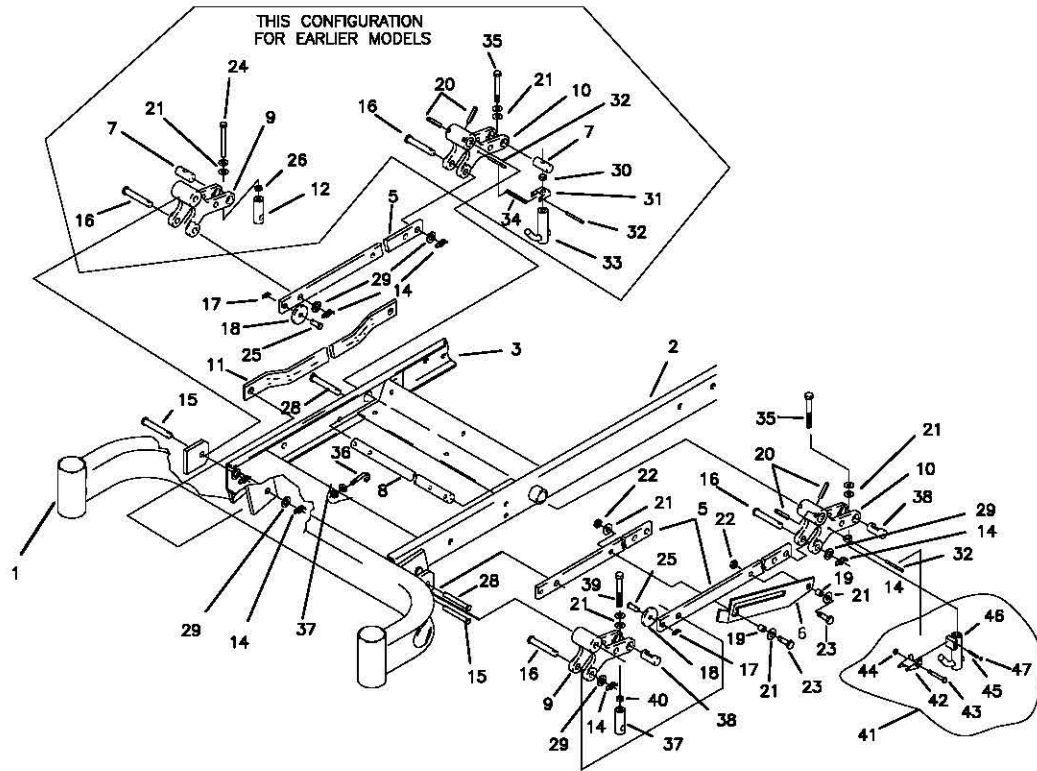

REF NO.	PART NO.	QTY.	DESCRIPTION
1	650-004W	1	FRONT AXLE WELDMENT
2	642-040W	1	FRAME WELDMENT, LH
3	642-039W	1	FRAME WELDMENT, RH
4	642-019W	1	FRONT PIVOT CHANNEL
5	642-059P	3	LINK BAR
6	642-100P	1	DECK LATCH (FLIP UP)
7	642-067P	4	TOP HANGER PIN
8	620-051P	1	LIFT BAR
9	642-081P	2	LIFT SLEEVE, FRONT
10	642-082P	2	LIFT SLEEVE, REAR
11	650-005P	1	LINK BAR
12	642-066P	2	ADJUSTABLE HANGER ROD
14	H-2239	8	RUE RING, 1/2"
15	F-1890	2	CLEVIS PIN, 1/2 X 3-1/2"
16	F-1898	4	CLEVIS PIN, 1/2 X 2-3/4"
17	F-1492	2	RUE RING, 5/16-3/8 PIN
18	642-105P	2	ROLLER
19	642-069P	2	SPACER, TOP PEG
20	F-1036-37	4	ROLL PIN, 5/16 DIA. X 1.750
21	F-1009-02	10	FLAT WASHER, 5/16"
22	F-1573	2	LOCK NUT 3/8-24
23	F-1572	2	3/8-24 X 1-1/2 HH GR. 5
24	F-1616	2	3/8-16 X 3-1/4" HH GR. 5
25	F-1691	2	CLEVIS PIN, 3/8 X 1"

REF NO.	PART NO.	QTY.	DESCRIPTION
26	F-1486	4	3/8-16 JAM NUT
37	F-1125	2	NUT, 5/16-18 STOVER
28	F-1896	2	CLEVIS PIN, 1/2 X 1-3/4"
29	F-1521	8	WASHER, 1/2 NARROW
31	642-151P	2	SPRING ANCHOR
32	F-1456	4	ROLL PIN, 3/16 X 2"
33	642-153W	2	HANGER END WELDMENT
34	H-2104	2	EXT. SPRING, 2-7/32 X .312
35	F-1066	2	CAPSCREW, 3/8-16 X 4"
36	F-1928	1	HOOK BOLT, 5/16-18 X 3"
37	642-175P	2	ADJUSTABLE HANGER END
38	642-177P	4	HANGER PIN
39	F-1936	4	1/2-13 X 3-1/2, 2" THREAD
40	F-1489	4	NUT, 1/2" JAM
41	642-183A	2	REAR DECK HANGER ASSEMBLY
42	642-178P	1	LATCH
43	F-1716	1	1/4 X 1-1/2" , G.5
44	F-1158	1	NUT, 1/4" STOVER
45	H-2390	1	SPRING, .219 OD X .024 WIRE
46	642-176W	1	REAR DECK HANGER WLDT
47	D-3723	1	1/4" CHROME STEEL BALL

**DOUBLE IDLER &
RELATED PARTS**

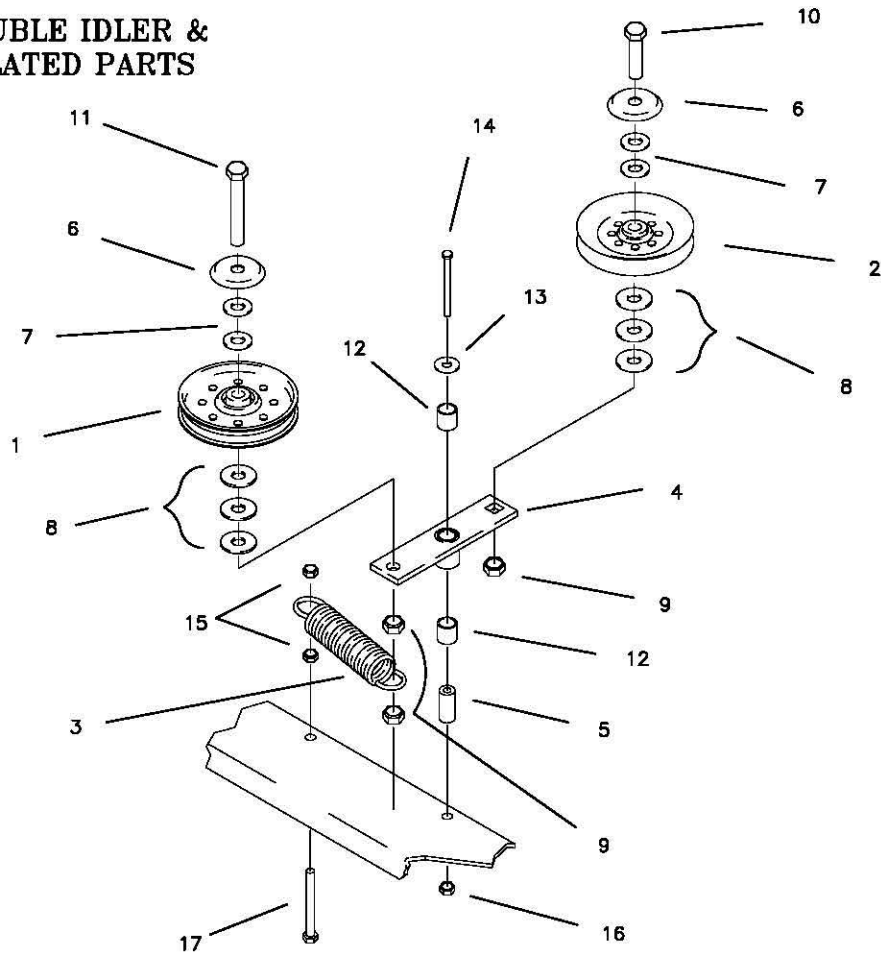

REF NO.	PART NO.	QTY.	DESCRIPTION
1	D-3617	1	FLAT IDLER PULLEY
2	D-3337	1	V-IDLER PULLEY
3	H-2092	1	SPRING
4	636-086W	1	IDLER ARM
5	621-103P	1	PIN
6	620-201P	2	BEARING CAP
7	F-1521	4	1/2" FLAT WASHER, (NARROW)
8	F-1009-05	6	1/2" FLAT WASHER, (STANDARD)
9	F-1005-05	3	1/2" LOCK NUT
10	F-1293	1	1/2-13 X 2" GR. 5
11	F-1668	1	1/2-13 X 2-3/4" GR. 5
12	D-3573	2	BUSHING DX 5/8 X 3/4
13	F-1009-02	1	5/16 FLAT WASHER
14	F-1820	1	5/16-18 X 2-1/4" GR. 5
15	F-1573	2	3/8-24 LOCK NUT
16	F-1125	1	5/16 LOCK NUT
17	F-1574	1	3/8-24 X 1 1/4" GR. 5
18	-	-	-

CASTER WHEEL ASSEMBLY

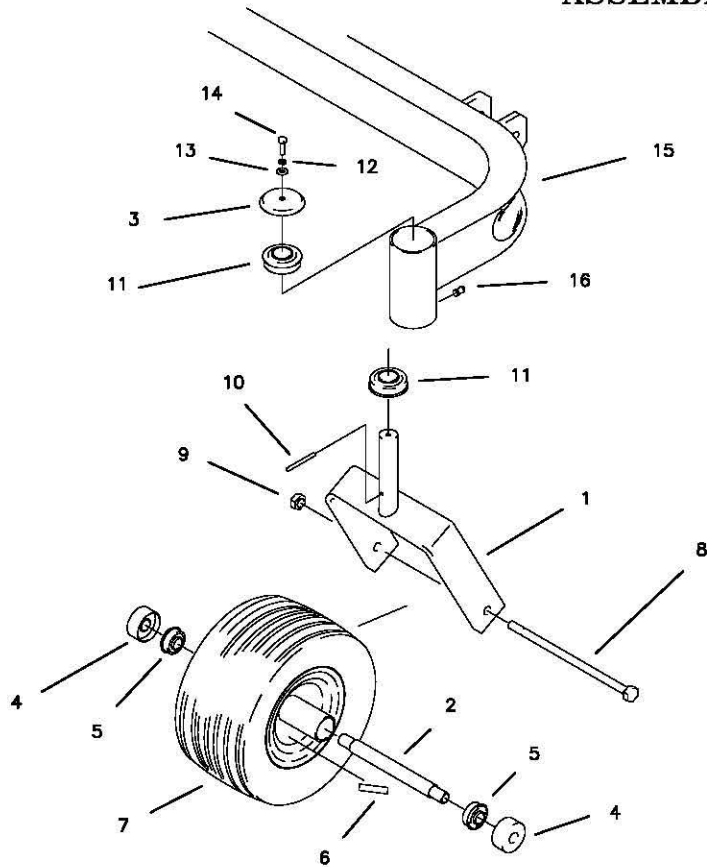

REF NO.	PART NO.	QTY.	DESCRIPTION
1	617-355W	2	CASTER WELDMENT
2	611-138P	2	BEARING SPACER
3	809-099P	2	BEARING CAP
4	611-135P	4	BEARING SHIELD
5	D-3432	4	BEARING, 5/8 ID X 1-3/8 OD
6	P-11384	2	DECAL, 12, PSI
7	D-3574	2	TIRE, 13.5 X 6 W/WHEEL
-	-	-	-
8	F-1129	2	1/2-13 X 8" GR. 5 BOLT
9	F-1005-05	2	1/2-13 LOCK NUT
10	F-1456	2	3/16 ROLL PIN
11	D-2008-02	4	BEARING, SPD SF-16-32
12	F-1009-01	2	1/4" FLAT WASHER
13	F-1019-01	2	1/4" LOCK WASHER
14	F-1810	2	1/4-20 X 3/4 W/NYLON PATCH
15	-----	1	SEE PAGE 1/6
16	H-1056	2	GREASE ZERK

FRAME SIDES & RELATED PARTS

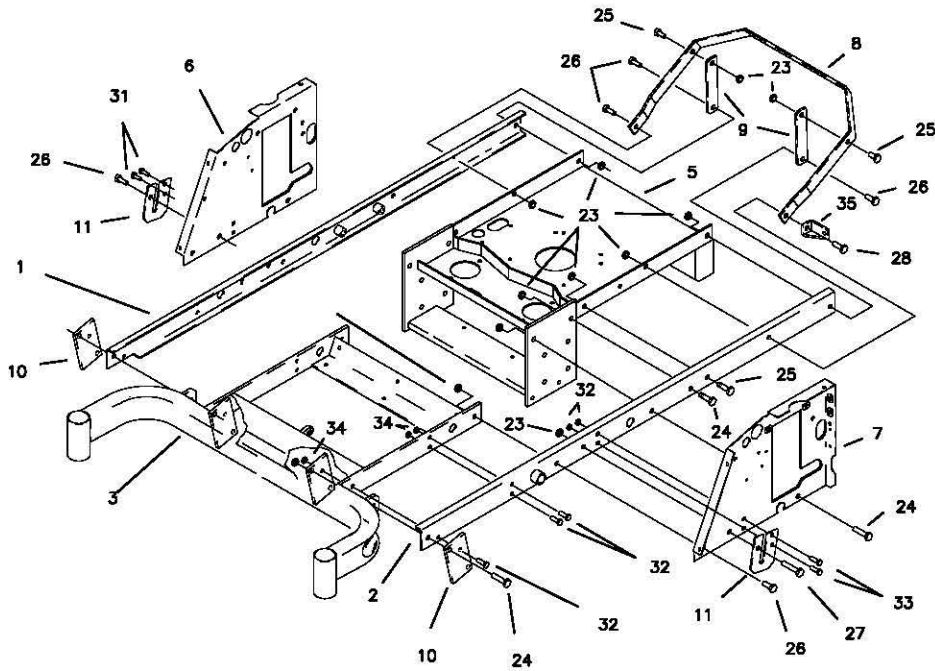

REF NO.	PART NO.	QTY.	DESCRIPTION	REF NO.	PART NO.	QTY.	DESCRIPTION
1	642-039W	1	FRAME SIDE RH.	21	-----	---	-----
2	642-040W	1	FRAME SIDE LH.	22	-----	---	-----
3	650-004W	1	FRONT AXLE	23	F-1005-05	16	1/2" LOCK NUT
4	-----	---	-----	24	F-1293	6	1/2-13 X 2" GR. 5
5	647-005W	1	MOTOR MOUNT WLDT.	25	F-1759	4	1/2-13 X 1" GR.5
6	642-049P	1	SIDE PANEL RH.	26	F-1386	4	1/2-13 X 1-1/4" GR. 5
7	642-050P	1	SIDE PANEL LH.	27	F-1828	1	1/2-13 X 3-1/2" GR. 5
8	642-093P	1	ENGINE GUARD	28	F-1526	1	1/2-13 X 1-1/2" GR. 5
9	642-015P	2	ENGINE GUARD MNT. LEG	29	-----	---	-----
10	642-063P	4	DRAG BAR TAB	30	-----	---	-----
11	642-042P	2	BRAKE ROD MOUNT	31	F-1558	4	3/8-16 X 7/8" GR. 5
12	-----	---	-----	32	F-1558	2	3/8-16 X 7/8" GR. 5
13	-----	---	-----	33	F-1307	2	3/8-16 X 1-1/4" GR. 5
14	-----	---	-----	34	F-1239	10	3/8-16 LOCK NUT
15	-----	---	-----	35	642-071W	1	SPRING ANCHOR
16	-----	---	-----				
17	-----	---	-----				
18	-----	---	-----				
19	-----	---	-----				
20	-----	---	-----				

FENDER ASSEMBLY

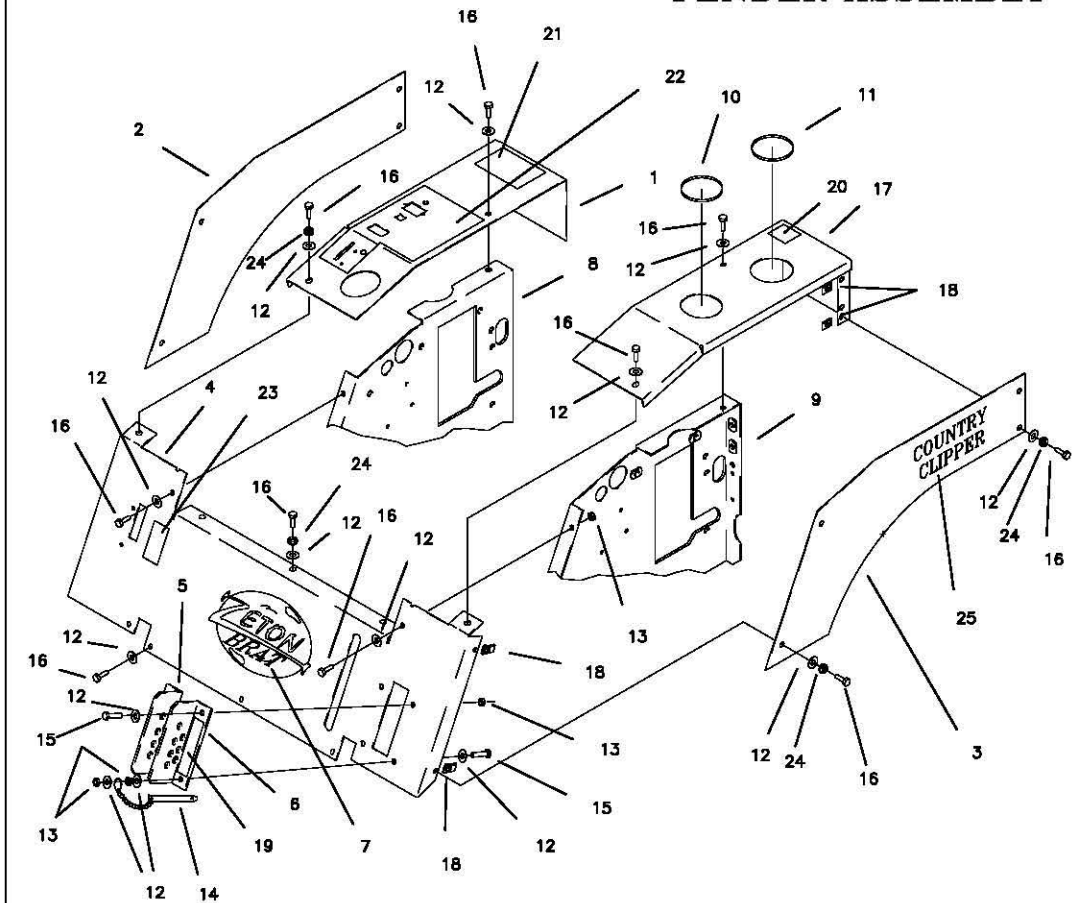

REF NO.	PART NO.	QTY.	DESCRIPTION	REF NO.	PART NO.	QTY.	DESCRIPTION
1	642-133A	1	FENDER CAP RH W/DECAL	17	642-170A	1	FENDER CAP LH. W/DECAL
-	642-140A	-	FDR. CAP RH. 2 LEV. W/DECAL	-	642-171A	-	FDR. CAP LH. 2 LEV. W/DECAL
-	647-068A	-	FDR. CAP RH W/EFI DECAL	18	F-1860	8	5/16 U-NUT
-	647-067A	-	FDR. CAP RH. 2 LEV. W/EFI DECAL	19	P-11407	1	DECAL, "CUT HEIGHT"
2	642-134A	1	FENDER SKIRT RH W/DECAL	20	P-10939	1	DECAL, "CAUTION"
3	642-135A	1	FENDER SKIRT LH W/DECAL	21	P-11307	1	DECAL, "WARNING"
4	650-017A	1	FRONT PANEL ASS'Y. W/DECAL	22	P-11369	1	DECAL, RH. FENDER CAP
5	642-137A	1	LATCH PLATE RH W/DECAL	23	P-11382	1	DECAL, PARK BRAKE
6	642-131P	1	LATCH PLATE LH.	24	F-1019-02	15	5/16 LOCK WASHER
7	P-11565	1	DECAL, ZETON	25	P-11112	2	DECAL, "COUNTRY CLIPPER"
8	642-049P	1	SIDE PANEL RH.				
9	642-050P	1	SIDE PANEL LH.				
10	644-029P	1	TRIM, FUEL TANK				
11	644-030P	1	TRIM, OIL TANK				
12	F-1009-02	27	5/16 FLAT WASHER				
13	F-1125	16	5/16-18 LOCK NUT				
14	F-1807	1	1/2" X 2.4 CLEVIS PIN W/SASH				
15	F-1879	3	5/16-18 X 1-1/4" GR. 5				
16	F-1015-15	21	5/16-18 X 1" GR.5				

SEAT, FOOTDECK &
RELATED PARTS

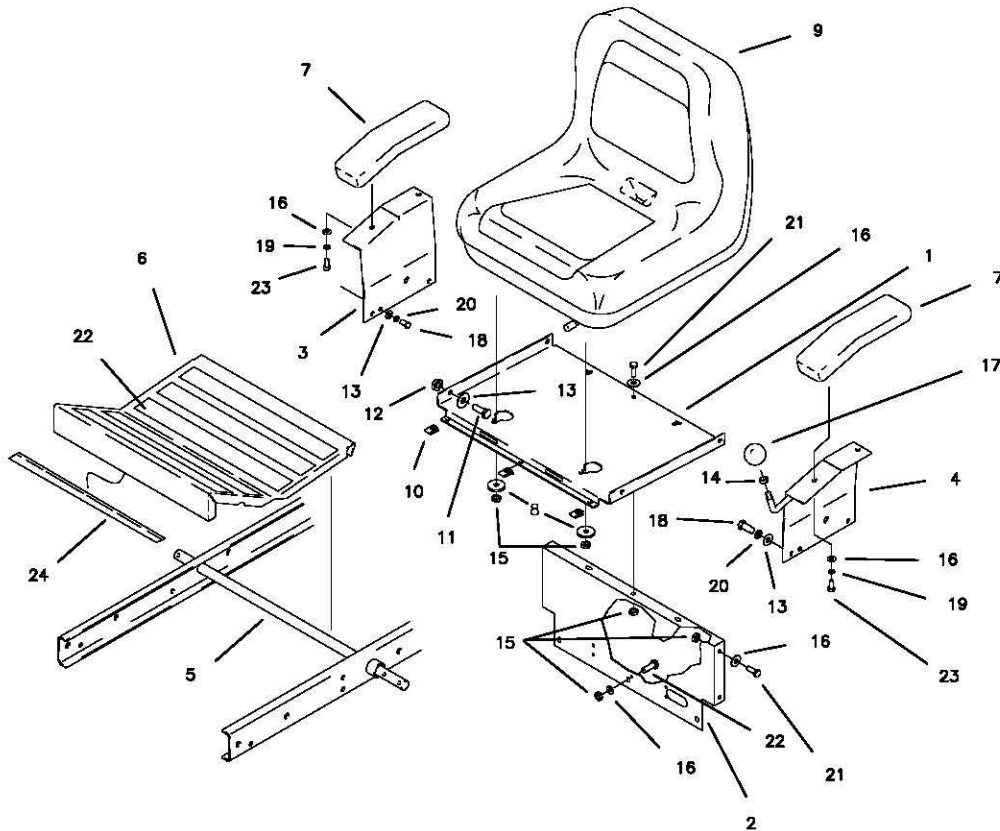

REF NO.	PART NO.	QTY.	DESCRIPTION	REF NO.	PART NO.	QTY.	DESCRIPTION
1	642-030P	1	SEAT BRACKET	17	H-2130	1	ROUND GRIP BALL
2	642-086P	1	REAR BRACE	18	F-1755	4	3/8-16 X 1/2" GR. 5
3	636-127P	1	ARM REST RH. (JOYSTICK)	19	F-1019-02	4	5/16 LOCK WASHER
-	636-163P	1	ARM REST, (TWIN STICK)	20	F-1019-03	4	3/8 LOCK WASHER
4	636-130W	1	ARM REST LH. (JOYSTICK)	21	F-1546	6	5/16-18 X 3/4" GR. 5
-	636-163P	1	ARM REST, (TWIN STICK)	22	H-1931	5	SAFETY TREAD
5	620-051P	1	LIFT BAR	23	F-1015-15	4	5/16-18 X 1" GR. 5
6	642-139A	1	FOOT DECK ASSEMBLY	24	650-017P	1	TRIM, U-CHANNEL, 18 3/4"
7	621-143A	2	ARM REST PAD				
8	609-034P	2	FLAT WASHER				
9	H-2274	1	SEAT--DELUXE				
	H-2229	1	SEAT--STANDARD				
10	F-1860	3	U-NUT 5/16-18				
11	F-1394	4	3/8-16 X 1" GR. 5				
12	F-1239	4	3/8-16 LOCK NUT				
13	F-1009-03	4	3/8 FLAT WASHER				
14	F-1011-03	1	3/8-16 PLAIN NUT				
15	F-1005-02	14	5/16-18 LOCK NUT				
16	F-1009-02	10	5/16 FLAT WASHER				

FUEL TANK ASSEMBLY

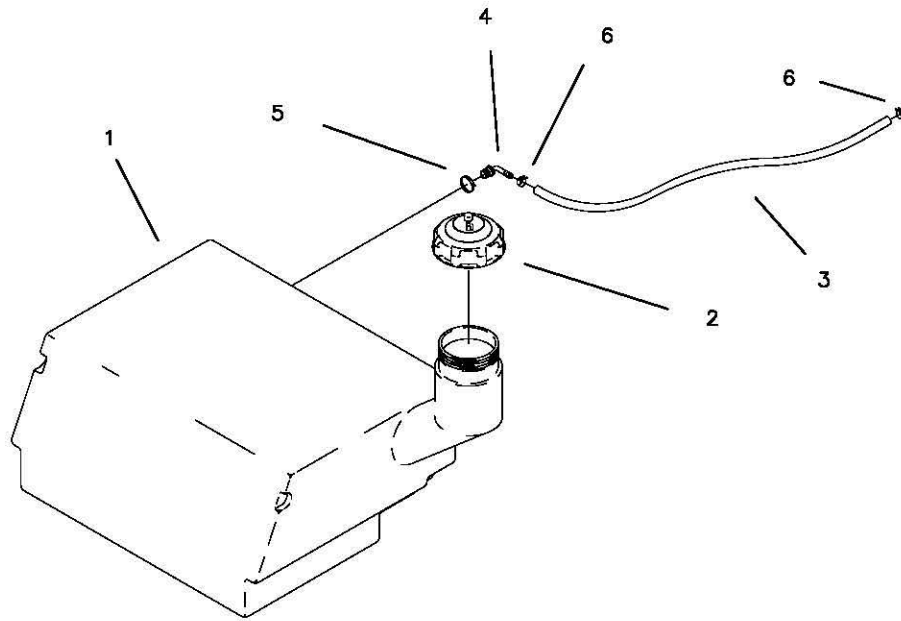

REF NO.	PART NO.	QTY.	DESCRIPTION
1	H-2234	1	11 GALLON TANK
2	H-2232	1	GAS CAP
3	644-034P	1	29-1/2" FUEL LINE
4	H-1646	1	HOSE BARB, 90 DEG.
5	H-1952	1	HOSE CLAMP
6	H-1687	2	HOSE CLAMP, 1/2"

JOYSTICK STEERING CONTROL AND RELATED PARTS

NOTE: ITEM'S #2 AND #3 MUST BE REPLACED AT THE SAME TIME FOR MAXIMUM PERFORMANCE.

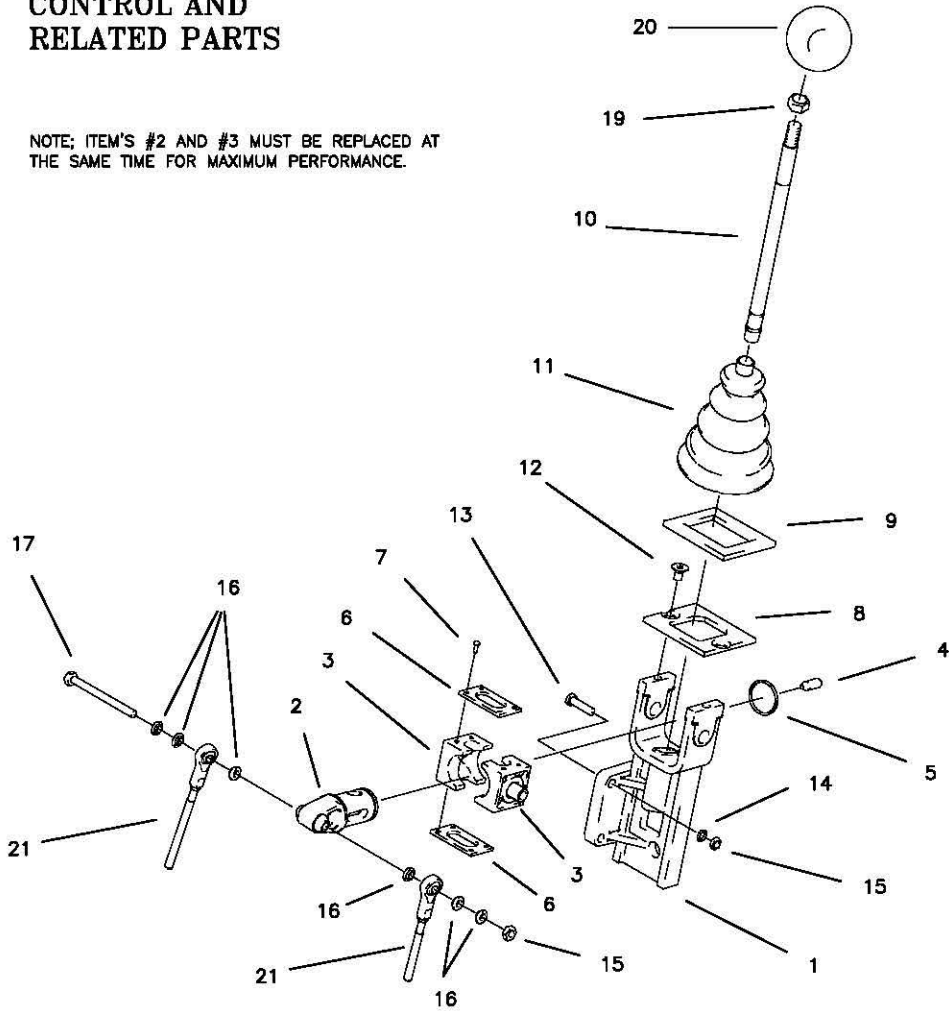

REF NO.	PART NO.	QTY.	DESCRIPTION	REF NO.	PART NO.	QTY.	DESCRIPTION
-	636-141A	1	JOYSTICK ASSEMBLY	11	H-1991	1	BOOT, BELLOWS
1	621-124P	1	JOYSTICK YOKE	12	F-1714	2	1/4-20 X 1/2" FHCS GR. 5
2	H-1992	1	PIVOT SHAFT	13	F-1015-05	3	1/4-20 X 1" HHCS GR. 5
3	619-307P	2	PIVOT BLOCK	14	F-1019-01	3	1/4" LOCK WASHER
4	F-1120	1	BALL PLUNGER	15	F-1158	4	1/4-20 LOCK NUT
5	H-1997	1	SNAP RING, SPIRLOCK	16	H-1989	6	BUSHING, BALL JOINT
6	619-306P	2	PIVOT BLOCK PLATE	17	F-1765	1	1/4-20 X 3" GR. 5
7	F-1624	8	#6-32 X 3/8" SCREW SLOT	18	-	-	-
8	636-140P	1	JOYSTICK TOP PLATE	19	F-1011-03	1	3/8-16 NUT, JAM
9	H-1947	1	GASKET, FOAM	20	H-2130	1	GRIP, BALL
10	621-140A	1	JOYSTICK SHAFT ASSEMBLY	-	-	-	-
				21	H-2125	2	LINKAGE ASSEMBLY

JOYSTICK STEERING
CONTROL AND
RELATED PARTS
(continued)

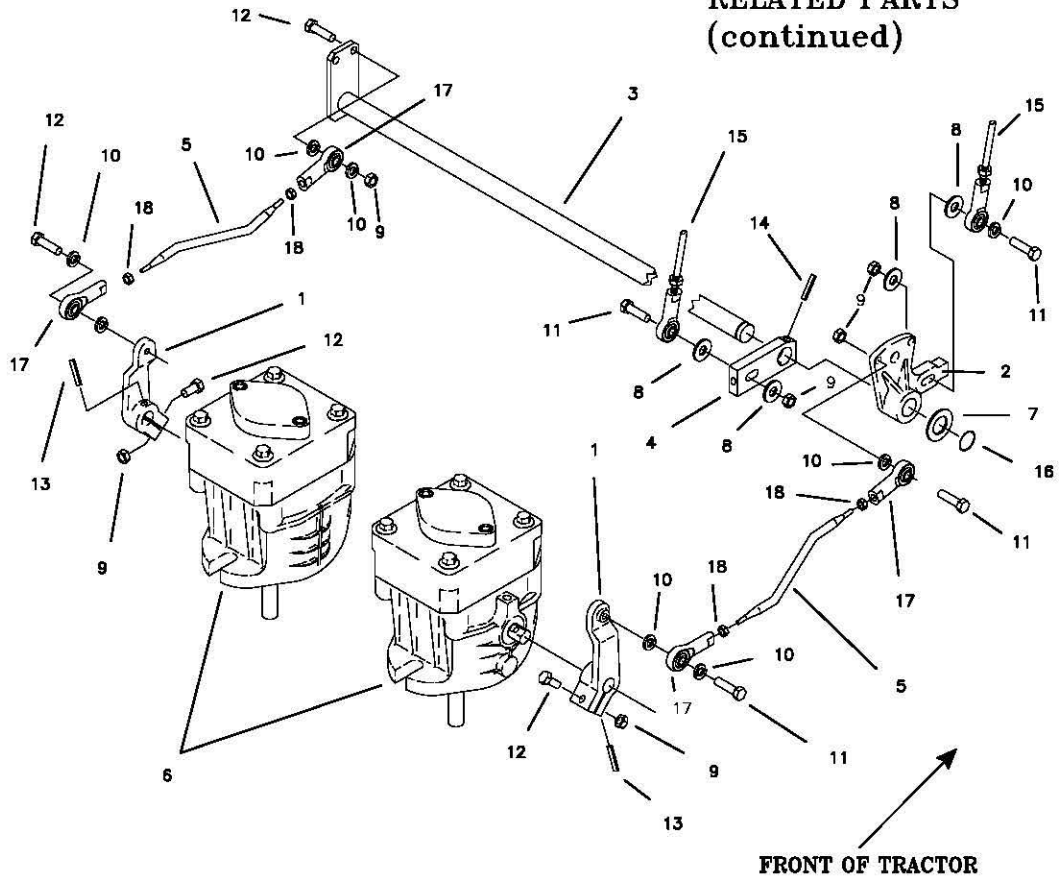

REF NO.	PART NO.	QTY.	DESCRIPTION
1	625-026P	2	SHIFT ARM
2	638-027A	1	LINKAGE DISK ASSEMBLY
3	636-078W	1	SHIFT ROD
4	625-030P	1	SWIVEL ARM
5	647-024P	2	LOWER LINKAGE ROD
6	-	-	SEE PAGE 3-20
7	610-103P	1	THRUST WASHER
8	F-1009-01	4	1/4" FLAT WASHER
9	F-1158	6	1/4-20 LOCK NUT
10	F-1019-01	8	1/4" LOCK WASHER
11	F-1718	4	1/4-20 X 1-1/2" GR. 5
12	F-1015-05	4	1/4-20 X 1" GR. 5
13	F-1725	2	ROLL PIN, 5MM X 26MM
14	F-1503	2	ROLL PIN, 3/16" X 1"
15	H-2125	2	UPPER LINKAGE
16	F-1739	1	SPIROL RING
17	H-1885	4	BALL JOINT
18	F-1487	4	1/4-28 NUT

RIGHT HAND STEERING CONTROL AND RELATED PARTS

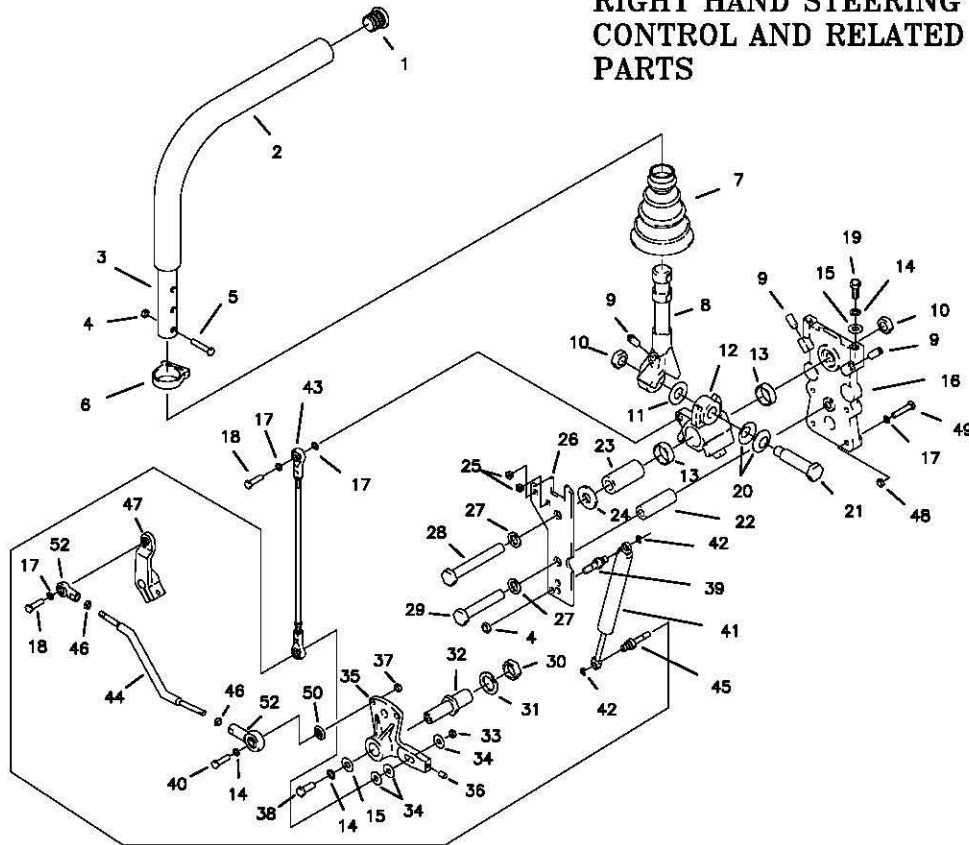

REF NO.	PART NO.	QTY.	DESCRIPTION	REF NO.	PART NO.	QTY.	DESCRIPTION
1	H-2080	1	END PLUG, 15/16" BLACK	27	F-1464	2	1/2" LOCK WASHER
2	H-2079	1	FOAM GRIP, 17"	28	F-1828	1	1/2-13 X 3-1/2" HHCS GR. 5
3	642-004A	1	CONTROL LEVER ASSEMBLY	29	F-1439	1	1/2-13 X 3" HHCS GR. 5
4	F-1125	3	5/16 LOCK NUT	30	F-1011-07	1	3/4-10 PLAIN NUT
5	F-1015-17	2	5/16-18 X 1-1/2" HHCS GR. 5	31	F-1463	1	3/4" LOCK WASHER
6	H-2089	1	HOSE CLAMP	32	623-048P	1	LINKAGE PINTLE
7	H-2081	1	BOOT, TAPERED 1" CUFF	33	F-1158	1	1/4-20 LOCK NUT
8	625-063P	1	LEVER, DUALEVER	34	F-1009-01	3	1/4" FLAT WASHER
9	F-1842	3	SETSCREW, 5/16-18 X 3/4"	35	638-027A	1	LINKAGE DISK ASSEMBLY
10	F-1489	2	1/2-13 JAM NUT	36	F-1695	1	SETCREW, 1/4-20 X 3/8"
11	H-2116	1	WASHER, FIBER	37	F-1011-01	1	1/4-20 PLAIN NUT
12	638-033P	1	PIVOT BLOCK, DUALEVER	38	F-1015-14	1	5/16-18 X 7/8" HHCS GR. 5
13	D-3622	2	BEARING	39	638-028P	1	DAMPER BOLT, 5-16-18 X 3/4"
14	F-1019-02	2	5/16" LOCK WASHER	40	F-1716	1	1/4-20 X 1-1/2" HHCS GR. 5
15	F-1009-02	2	WASHER, FLAT STD. 5/16"	41	H-2168	1	STEERING DAMPER
16	638-034P	1	BASE DUALEVER	42	F-1610	2	E-RING FOR 1/4" SHAFT
17	F-1019-01	11	1/4" LOCK WASHER	43	H-2125	1	UPPER LINKAGE
18	F-1015-05	1	1/4-20 X 1" HHCS GR. 5	44	647-024P	1	LOWER LINKAGE
19	F-1546	1	5/16-18 X 3/4" HHCS GR. 5	45	638-029P	1	DAMPER BOLT, 1/4-20
20	H-2115	2	WASHER, SPRING	46	F-1487	2	NUT, HEX 1/4-28 UNF
21	625-070P	1	SHOULDER BOLT, 5/8" OD	47	625-026P	1	SHIFT ARM
22	625-067P	1	BUSHING, STAND OFF	48	F-1158	4	1/4" LOCK NUT
23	625-064P	1	BUSHING, PIVOT BLOCK	49	F-1539	3	1/4-20 X 1-1/4" HHCS GR. 5
24	625-072P	1	WASHER, FLAT	50	H-1987	1	BUSHING, LARGE
25	F-1847	2	GROMMET, #4 X 1/4" SQ.	51	H-1989	1	BUSHING, SMALL
26	625-065P	1	TOP PLATE, DUALEVER	52	H-1885	2	BALL JOINT

LEFT HAND STEERING
CONTROL AND RELATED
PARTS

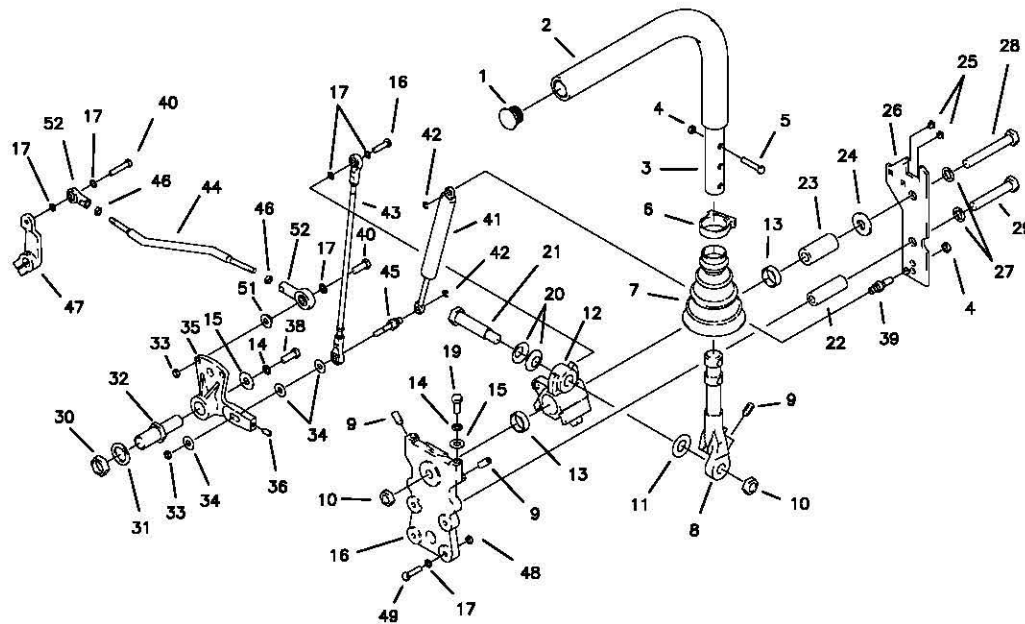

REF NO.	PART NO.	QTY.	DESCRIPTION	REF NO.	PART NO.	QTY.	DESCRIPTION
1	H-2080	1	END PLUG, 15/16" BLACK	27	F-1464	2	1/2" LOCK WASHER
2	H-2079	1	FOAM GRIP, 17"	28	F-1828	1	1/2-13 X 3-1/2" HHCS GR. 5
3	642-004A	1	CONTROL LEVER ASSEMBLY	29	F-1439	1	1/2-13 X 3" HHCS GR. 5
4	F-1125	3	5/16 LOCK NUT	30	F-1011-07	1	3/4-10 PLAIN NUT
5	F-1015-17	2	5/16-18 X 1-1/2" HHCS GR. 5	31	F-1463	1	3/4" LOCK WASHER
6	H-2089	1	HOSE CLAMP	32	623-048P	1	LINKAGE PINTLE
7	H-2081	1	BOOT, TAPERED 1" CUFF	33	F-1158	1	1/4-20 LOCK NUT
8	625-063P	1	LEVER, DUALEVER	34	F-1009-01	3	1/4" FLAT WASHER
9	F-1842	3	SETSCREW, 5/16-18 X 3/4"	35	638-027A	1	LINKAGE DISK ASSEMBLY
10	F-1489	2	1/2-13 JAM NUT	36	F-1695	1	SETCREW, 1/4-20 X 3/8"
11	H-2116	1	WASHER, FIBER	37	F-1011-01	1	1/4-20 PLAIN NUT
12	638-033P	1	PIVOT BLOCK, DUALEVER	38	F-1015-14	1	5/16-18 X 7/8" HHCS GR. 5
13	D-3822	2	BEARING	39	638-028P	1	DAMPER BOLT, 5-16-18 X 3/4"
14	F-1019-02	2	5/16" LOCK WASHER	40	F-1015-05	1	1/4-20 X 1" HHCS GR. 5
15	F-1009-02	2	WASHER, FLAT STD. 5/16"	41	H-2188	1	STEERING DAMPER
16	638-034P	1	BASE DUALEVER	42	F-1610	2	E-RING FOR 1/4" SHAFT
17	F-1019-01	11	1/4" LOCK WASHER	43	H-2125	1	UPPER LINKAGE
18	F-1015-05	1	1/4-20 X 1" HHCS GR. 5	44	647-024P	1	LOWER LINKAGE
19	F-1546	1	5/16-18 X 3/4" HHCS GR. 5	45	638-029P	1	DAMPER BOLT, 1/4-20
20	H-2115	2	WASHER, SPRING	46	F-1487	2	NUT, HEX 1/4-28 UNF
21	625-070P	1	SHOULDER BOLT, 5/8" OD	47	625-026P	1	SHIFT ARM
22	625-067P	1	BUSHING, STAND OFF	48	F-1158	4	1/4" LOCK NUT
23	625-064P	1	BUSHING, PIVOT BLOCK	49	F-1539	3	1/4-20 X 1-1/4" HHCS GR. 5
24	625-072P	1	WASHER, FLAT	50	-	-	-
25	F-1847	2	GROMMET, #4 X 1/4" SQ.	51	H-1989	1	BUSHING, SMALL
26	625-065P	1	TOP PLATE, DUALEVER	52	H-1885	2	BALL JOINT

PARKING BRAKE ASSEMBLY & RELATED PARTS

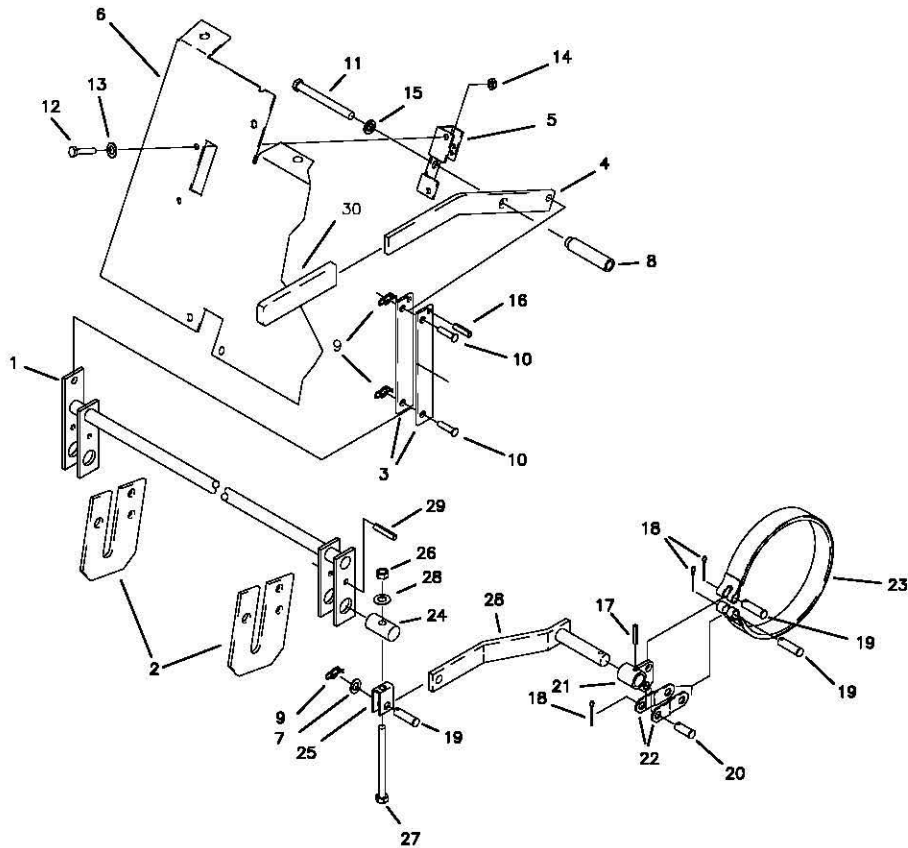

REF NO.	PART NO.	QTY.	DESCRIPTION	REF NO.	PART NO.	QTY.	DESCRIPTION
1	647-014W	1	BRAKE ROD WELDMENT	21	647-029W	1	BRAKE ARM SHORT, LH.
2	642-042P	2	BRAKE ROD MOUNT	-	647-028W	1	BRAKE ARM SHORT, RH.
3	642-058P	2	BRAKE LINK	22	647-010P	4	BRAKE ANCHOR LINK
4	642-056P	1	BRAKE HANDLE	23	D-3668	2	BRAKE BAND
5	642-054P	1	BRAKE SWITCH BRACKET	24	642-067P	2	TOP HANGER PIN
6	642-057P	1	FRONT PANEL	25	647-030P	2	BRAKE YOKE LINKAGE
7	F-1009-02	1	5/16 FLAT WASHER	26	F-1125	2	5/16-18 LOCK NUT
8	642-027P	1	BRAKE PIVOT TUBE	27	F-1682	2	5/16-18 X 4" GR. 5
9	F-1492	3	RUE RING	28	647-013W	1	BRAKE ARM WLDT., LONG
10	F-1443	2	5/16" PIN	29	F-1604	1	1/4" X 1 1/4" ROLL PIN
11	F-1827	1	3/8-16 X 3-1/2" GR. 5	30	H-1926	1	HANDLE GRIP
12	F-1538	2	1/4-20 X 3/4" GR. 5				
13	F-1009-01	4	1/4" FLAT WASHER				
14	F-1005-01	2	1/4-20 LOCK NUT				
15	F-1019-03	1	3/8" LOCK WASHER				
16	F-1831	1	1/4 X 1" ROLL PIN				
17	F-1553	2	3/16 X 7/8" ROLL PIN				
18	F-1491	3	COTTER PIN, 1/8 X 1"				
19	F-1444	3	CLEVIS PIN, 3/8 X 1-5/16"				
20	F-1438	1	CLEVIS PIN, 3/8 X 3/4"				

GEAR MOTOR, WHEEL ASSEMBLY

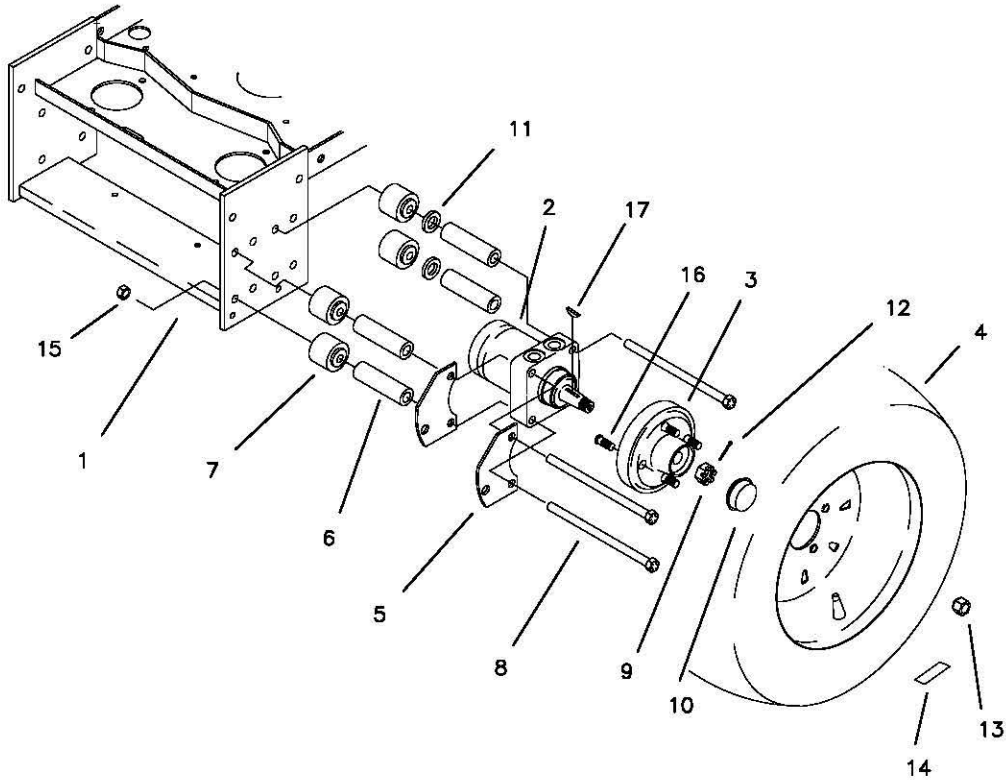

REF NO.	PART NO.	QTY.	DESCRIPTION
1	647-003W	1	MOTOR MOUNT
2	D-3667	2	WHEEL MOTOR
3	647-041P	2	WHEEL HUB W/STUDS
4	D-3637	2	TIRE W/RIM, 23-9.50-12
5	647-017P	4	BRAKE MOUNT PLATE
6	647-039P	8	SPACER, LONG
7	647-040P	8	SPACER, SHORT
8	F-1908	8	CAPSCREW, 1/2-13 X 9" GR. 8
9	F-1909	2	NUT, 3/4-16 CASTLE NUT
10	H-1798	2	GREASE CAP
11	612-109P	4	WASHER
12	H-1376	2	COTTER PIN, 1/8 X 1-1/2"
13	F-1499	8	LUG NUT, 1/2-20 X 60 DEG.
14	P-10877	2	DECAL, TIRE PRESSURE
15	F-1005-05	8	1/2-13 LOCK NUT
16	F-1654	8	WHEEL STUD, (REPLACEMENT)
17	D-1004-01	1	KEY, 1/4 X 1" WOODRUFF

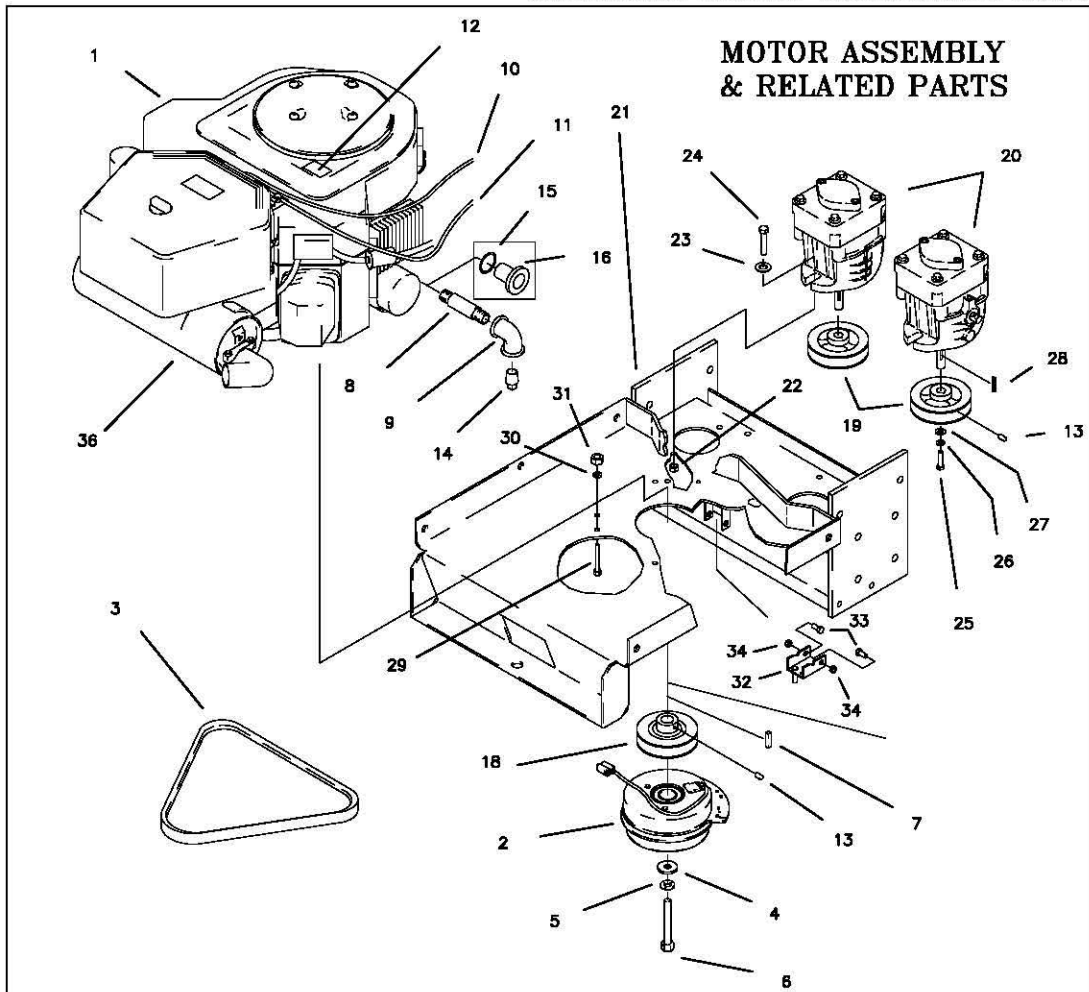

**MOTOR ASSEMBLY
& RELATED PARTS**

REF NO.	PART NO.	QTY.	DESCRIPTION	REF NO.	PART NO.	QTY.	DESCRIPTION
1	M-5329	1	17 HP. KAWASAKI ENGINE	15	D-3446	1	3/4-16 PORT O-RING
-	M-5330	1	19 HP. KAWASAKI ENGINE	16	H-2285	1	DRAIN ADAPTER
-	-	-	-	18	648-037P	1	MOTOR PULLEY
2	E-6317	1	CLUTCH, MAGSTOP 1"	19	647-035P	2	HYDRO PUMP PULLEY
3	D-3671	1	HYDRO PUMP BELT	20	-	-	SEE PAGE 3-20
4	606-347P	1	WASHER	21	647-005W	1	MOTOR MOUNT
5	F-1019-04	1	7/16 LOCK WASHER	22	F-1005-03	4	NUT, 3/8-16 STOVER
6	F-1904	1	7/16-20 X 2-1/2"	23	F-1009-03	4	3/8 FLAT WASHER
7	621-113P	1	KEY, 1/4 SQ. X 1-1/4"	24	F-1307	4	3/8-16 X 1-1/4" GR. 5
8	H-1089	1	3/8 X 2" PIPE NIPPLE	25	F-1737	2	6MM X 16MM GR. 5
9	H-1218	1	3/8" PIPE ELBOW	26	F-1738	2	6MM WASHER
10	H-2287	1	CHOKE CABLE	27	620-187P	2	WASHER
11	H-2286	1	THROTTLE CABLE	28	D-3541	2	KEY, 5MM.
12	P-10077	1	DECAL, "CLEAN"	29	F-1015-17	3	5/16-18 X 1-1/2" GR. 5
13	F-1228	3	SETSCREW, 1/4" X 1/4"	30	F-1019-02	4	5/16" LOCK WASHER
14	H-1380	1	PLUG, 3/8" NPT	31	F-1011-02	4	5/16-18 PLAIN NUT
				32	647-023W	1	CLUTCH STOP WELDMENT
				33	F-1538	2	1/4-20 X 3/4" GR. 5
				34	F-1158	2	1/4-20 LOCK NUTS
				36	H-2284	1	MUFFLER ASSEMBLY

HIGH PRESSURE LINES & FITTINGS

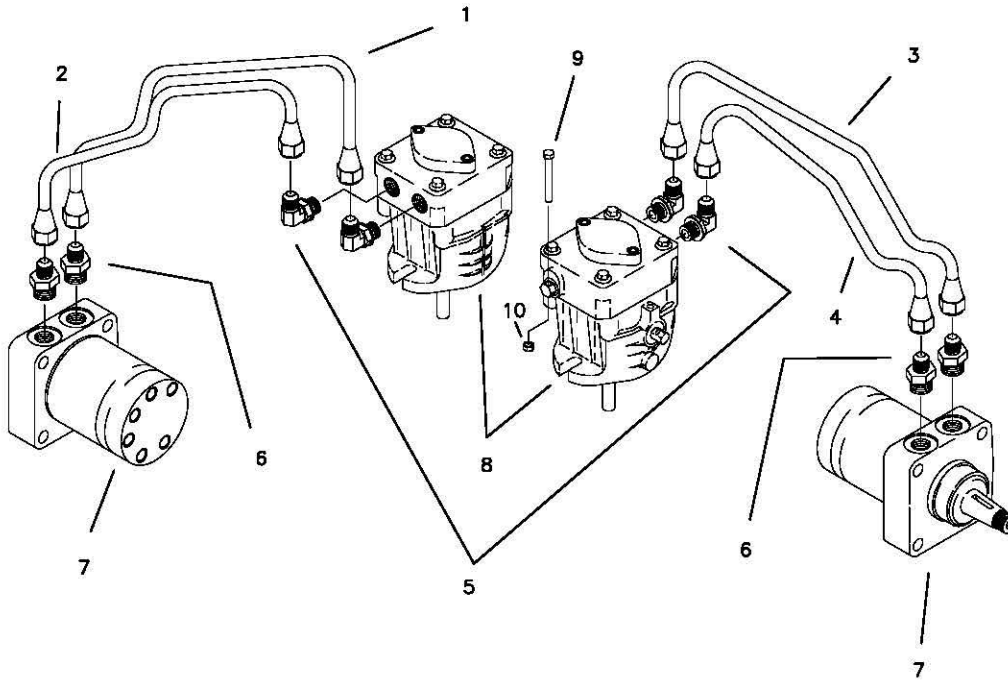

VIEWED FROM RIGHT REAR

REF NO.	PART NO.	QTY.	DESCRIPTION
1	H-2369	1	TUBE ASS'Y, RH. FORWARD
2	H-2370	1	TUBE ASS'Y, RH. REVERSE
3	H-2367	1	TUBE ASS'Y, LH. FORWARD
4	H-2368	1	TUBE ASS'Y, LH. REVERSE
5	H-2318	4	FITTING, 90 DEG. ELBOW, 3/4-16
6	H-2319	4	FITTING, STRAIGHT, 7/8-14
7	D-3667	2	WHEEL MOTOR
8	D-3666	2	HYDRAULIC PUMP
9	F-1077	2	1/4-20 X 2" GR. 5 (FOR HANDLE)
10	F-1158	2	1/4-20 LOCK NUT

OIL RETURN LINES & COOLER ASSEMBLY

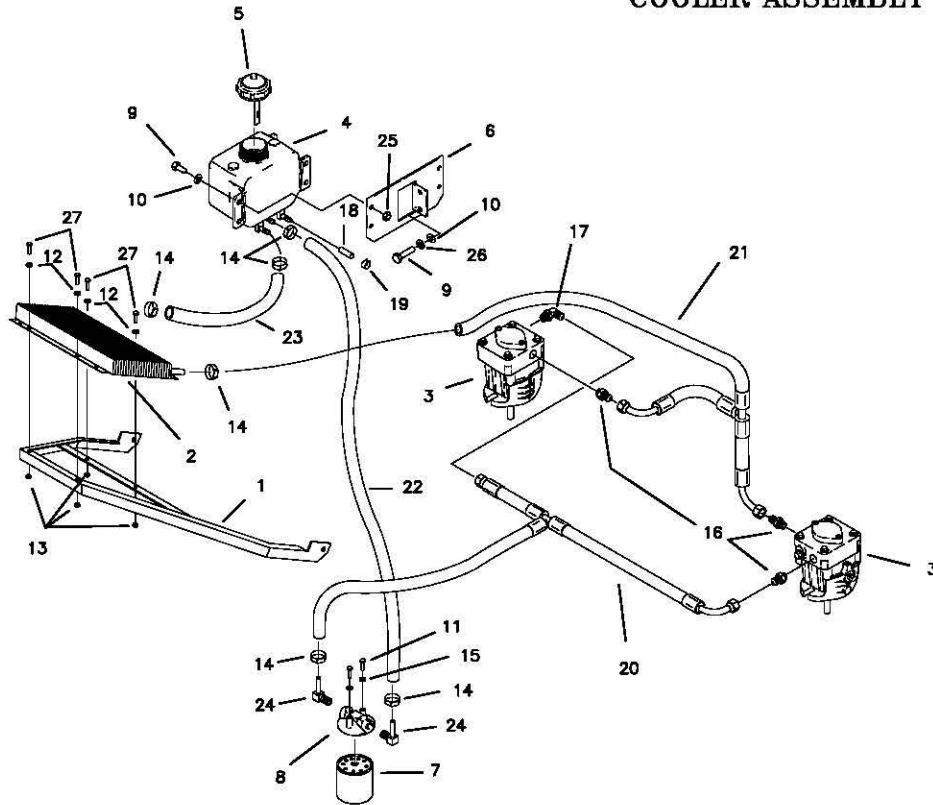

REF NO.	PART NO.	QTY.	DESCRIPTION	REF NO.	PART NO.	QTY.	DESCRIPTION
1	647-046W	1	BRACKET, OIL COOLER	20	H-2328	1	HOSE, SUCTION
2	H-2325	1	OIL COOLER	21	H-2329	1	HOSE, RETURN
3	-	-	SEE PAGE 3-20	22	H-2333	1	HOSE, 18" HI-TEMP
4	H-2230	1	TANK, 2 QUART	23	H-2332	1	HOSE, 16" HI-TEMP
5	644-035A	1	CAP, HYDRO TANK	24	H-1859	2	ELBOW, 1/4 PIPE & HOSE BARB
6	642-052P	1	TANK MOUNT BRACKET	25	F-1125	4	5/16-18 STOVER NUT
7	H-2026	1	FILTER, HYDRO	26	F-1019-02	2	5/16- LOCK WASHER
8	H-2061	1	FILTER BASE	27	F-1538	4	1/4-20 X 3/4" GR. 5
9	F-1546	6	5/16 X 3/4 GR. 5				
10	F-1009-02	4	5/16 FLAT WASHER				
11	F-1015-05	2	1/4-20 X 1" GR. 5				
12	F-1009-01	4	1/4" FLAT WASHER				
13	F-1158	4	1/4" LOCK NUT				
14	H-2282	6	HOSE CLAMP				
15	F-1019-01	2	LOCK WASHER				
16	H-2330	3	ADAPTER				
17	H-2331	1	ELBOW				
18	H-2327	1	CAPLUG, 3/8 X 1"				
19	H-1687	1	HOSE CLAMP				

MOTOR TO PUMP SINGLE IDLER

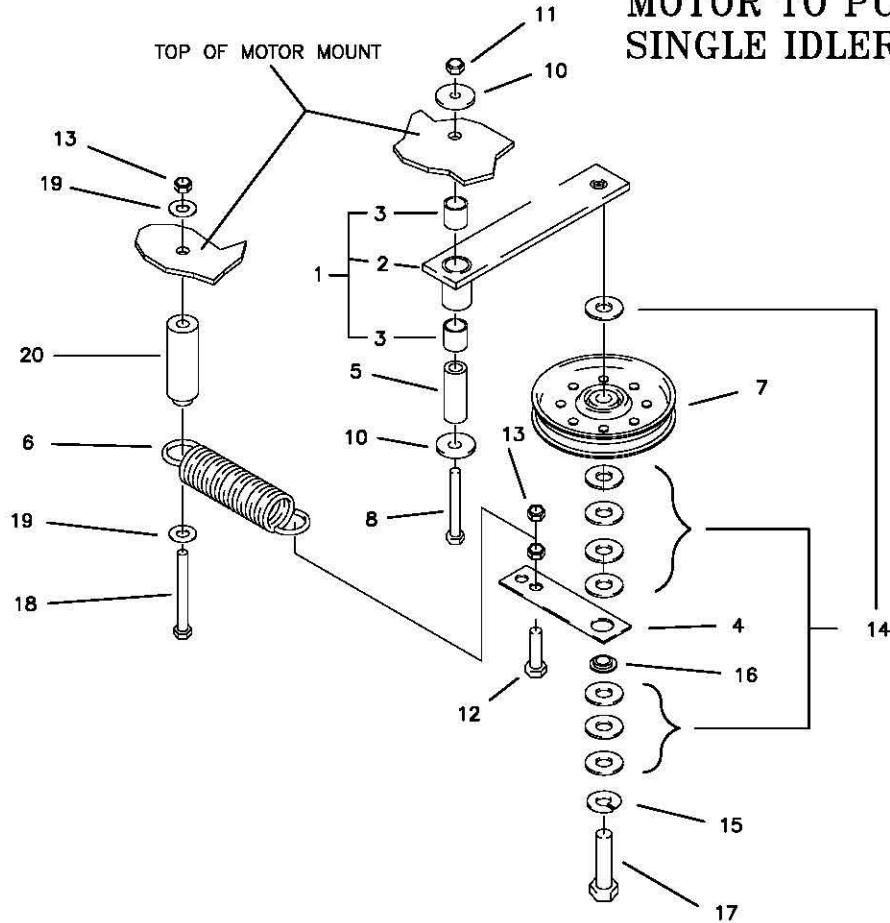

REF NO.	PART NO.	QTY.	DESCRIPTION
1	622-167A	1	SINGLE IDLER ASSEMBLY
2	622-051W	1	SINGLE IDLER WELDMENT
3	D-3573	2	BUSHING, DX 5/8 X 3/4"
4	622-047P	1	SPRING EXTENSION
5	621-103P	1	MOUNTING PIN
6	H-2092	1	SPRING
7	D-3617	1	FLAT IDLER PULLEY
8	F-1820	1	5/16-18 X 2-1/4" HHCS GR. 5
-	-	-	-
10	F-1009-02	2	5/16" FLAT WASHER
11	F-1125	1	5/16 LOCK NUT
12	F-1445	1	3/8-24 X 1" HHCS GR. 5
13	F-1573	3	3/8-24 LOCK NUT
14	F-1521	8	1/2" FLAT WASHER
15	F-1464	1	1/2" LOCK WASHER
16	622-048P	1	IDLER STAND
17	F-1293	1	1/2-13 X 2" GR. 5
18	F-1066	1	3/8-16 X 4" GR.5
19	F-1009-03	2	3/8 FLAT WASHER
20	642-163P	1	SPRING ANCHOR BUSHING

WIRE HARNESS & RELATED PARTS

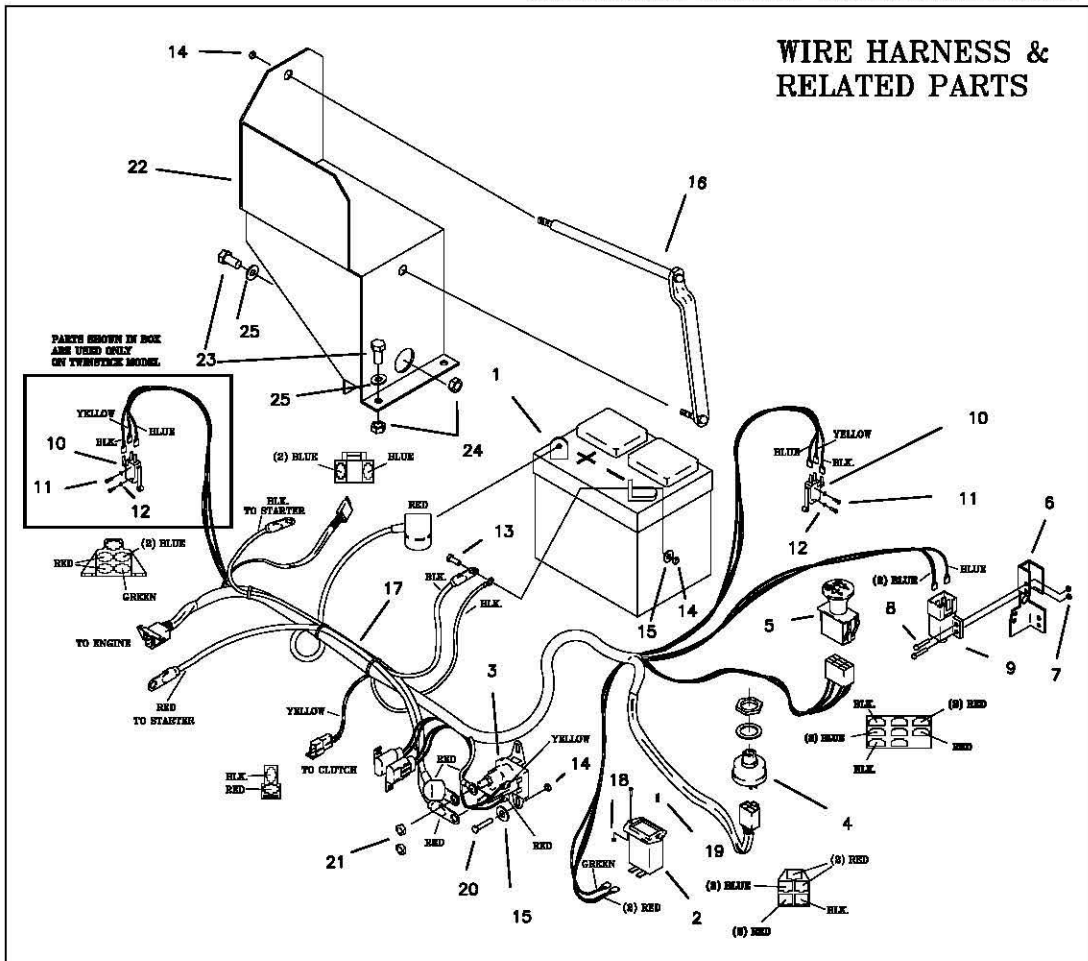

REF NO.	PART NO.	QTY.	DESCRIPTION
1	E-6271	1	BATTERY USED ON 17 HP
-	E-6271	1	BATTERY USED ON 19 HP
2	E-5878	1	HOUR METER
3	E-6054	1	SOLENOID
4	E-5873	1	START SWITCH
5	E-6296	1	CLUTCH SWITCH
6	642-054P	1	BRAKE SWITCH BRACKET
7	F-1448	2	8-32 LOCK NUT
8	F-1022-26	2	8-32 X 5/8 SCREW
9	E-6297	1	BRAKE SWITCH
10	E-6074	1	SWITCH, SPDT MINI
-	E-6074	2	USED ON TWINSTICK
11	F-1398	2	4-40 X 3/4 SCREW
-	F-1398	4	USED ON TWINSTICK
12	F-1621	2	STAR WASHER
-	F-1621	4	USED ON TWINSTICK
13	F-1538	2	1/4-20 X 3/4" GR. 5
14	F-1158	5	1/4-20 LOCK NUT
15	F-1009-01	4	1/4" FLAT WASHER
16	647-006A	1	BATTERY HOLD DOWN

REF NO.	PART NO.	QTY.	DESCRIPTION
17	E-6298	1	WIRE HARNESS
18	F-1535	2	6-32 LOCK NUT
19	F-1054	2	6-32 X 5/8" MACHINE SCREW
20	F-1015-02	2	1/4-20 X 5/8" GR. 5
21	F-1567	2	5/16-24 NUT
	E-6281	1	COVER (KEY SWITCH)
			-NOT SHOWN-
	E-6307	1	OIL PRESSURE SWITCH
			-NOT SHOWN-
	E-6309	1	WIRE HARNESS ADAPTER
			-NOT SHOWN-
22	647-008W	1	BATTERY BOX
23	F-1015-15	3	5/16-18 X 1" GR. 5
24	F-1125	3	5/16-18 LOCK NUT
25	F-1009-02	3	5/16 WASHER